**User and Service
Guide**

**HP SureStore E
Disk System FC10**

HP SureStore E

Disk System FC10

User and Service Guide



Edition E1299
Order No. A5236-90001
Printed in U.S.A.

Notice

© Hewlett-Packard Company, 1999. All rights reserved.

Hewlett-Packard Company makes no warranty of any kind with regard to this document, including, but not limited to, the implied warranties of merchantability and fitness for a particular purpose. Hewlett-Packard shall not be liable for errors contained herein or for incidental or consequential damages in connection with the furnishing, performance, or use of this material.

This document contains proprietary information, which is protected by copyright. No part of this document may be photocopied, reproduced, or translated into another language without the prior written consent of Hewlett-Packard. The information contained in this document is subject to change without notice.

Warranty

If you have any questions about the warranty for this product, contact your dealer or local Hewlett-Packard sales representative.

Safety Notices

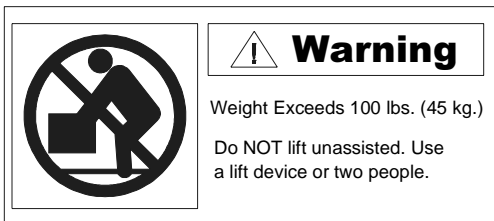

To protect against personal injury and product damage, do not attempt to lift the product without the assistance of another person or lift device.



Components bearing this symbol may be hot to touch.



Components bearing this symbol are fragile. Handle with care.



Components bearing this symbol are susceptible to damage by static electricity. ESD precautions are required.

Operation

The front door should be closed and locked at all times during the operation of this product except when replacing disks.

This product is intended to be operated in a restricted access area.

Service

Maintenance or repair of the power switch, backplane, and mezzanine must be performed by authorized service-trained personnel.

Format Conventions

Denotes

WARNING

A hazard that can cause personal injury

Caution

A hazard that can cause hardware or software damage

Note

Significant concepts or operating instructions

this font

Text to be typed verbatim: all commands, path names, file names, and directory names

`this font`

Text displayed on the screen

CONTENTS

1 Product Description

General Description	16
Features	17
Status Indicators	19
Power Button	19
High Availability	20
Upgradability	20
Enclosure Services	21
Hardware Event Monitoring	21
Components	22
Disks	22
LCCs	24
GBICs	25
Fans	26
Power Supplies	27
Topologies	29
Redundant Hubs on Redundant Servers	30
No-Hub Configuration	31
Long-Wave Hub Configuration	32
Definitions	34

2 Installation

Electrical Preparation	36
Electrical Requirements	36

Choosing PDUs	37
Installing PDUs	39
Tools	42
Step 1: Unpack the Product	42
Step 2A: Install Rails (for Legacy Racks)	45
Step 2B: Install Rails (for System/E Racks)	48
Step 3: Prepare Rack Front	54
Step 4: Mount the Disk System	56
Step 5: Install GBICs and LCCs	60
Step 6: Set the Enclosure ID	62
Step 7: Connect Fiber Optic and Power Cables	63
Step 8: Install Disks and Fillers	66
Step 9: Turn on the Disk System	69

3 Configuration

Viewing a Disk System in IOSCAN	72
Sample IOSCAN	72
Interpreting the Hardware Path	74
Loop IDs and Hardware Paths by Enclosure ID	75
Setting Up the Hardware Event Monitor	77
Annotating Devices	78
Using SAM	78
Using STM (HP-Qualified Only)	79
Updating Firmware (HP-Qualified Only)	80

4 Troubleshooting

Overview	84
Event Notification	85

Status LEDs	88
Online Status Information	91
Viewing Component Status in SAM	91
Viewing the STM Information Log	94
Interpreting Status Values	96
Checking the Fibre Channel Link	97
Isolating Causes	99

5 Removal and Replacement

Disk or Filler	106
System Administration	106
Using STM to Flash LEDs	111
Tools	113
Procedure to Remove a Disk or Filler	113
Procedure to Replace a Disk	115
GBIC	118
Tools	118
Procedure	118
LCC	120
Tools	120
Procedure	120
Fan	124
Tools	124
Procedure	124
Power Supply	126
Tools	126
Procedure	126
Disk System	128

Tools	128
Procedure to Remove a Disk System	128
Procedure to Replace a Disk System	130
Door	131
Tools	131
Procedure	131
Top Cover (HP-Qualified Only)	133
Tools	133
Procedure to Remove the Top Cover	133
Procedure to Replace the Top Cover	135
Backplane/Mezzanine (HP-Qualified Only)	136
Tools	136
Procedure	137

6 Reference

Product Models and Options	142
Upgrade Products	143
PDU/PDRU Products	144
Replaceable Parts	145
Hardware/Software Requirements	146
Specifications	147
Dimensions	147
Weight	147
AC Power Input	148
Power Consumption	148
DC Power Output	148
Heat Output	148
Environment	148

Acoustics	149
Safety Certifications	150
EMC Compliance	150
Regulatory Statements	151
Laser Safety	153
Declaration of Conformity	156

Index

FIGURES

1	Disk System: Front and Back Views	18
2	Disk	23
3	LCC	24
4	GBIC	25
5	Fan	26
6	Power Supply	27
7	Redundant Hubs on Redundant Host/Servers	30
8	Redundant Adapters on One Server	31
9	Redundant Adapters on Four Servers	33
10	PDU Placement in 1.6 Meter Rack	40
11	PDRU Placement in 2.0 Meter Rack	41
12	Disk System Accessories	43
13	Disk System Chassis Contents	44
14	Rail Kit A5250A Contents	45
15	Rack Column Detail – Legacy Racks	46
16	Rail Assembly – Legacy Racks	47
17	Rail Kit A5251A Contents	49
18	EIA Unit Rail Position	50
19	Mid-EIA Unit Rail Position	51
20	Rail Assembly – Rack Systems/E	53
21	Rack Front Preparation: EIA Unit Rail Position	54
22	Rack Front Preparation: Mid-EIA Unit Rail Position	55
23	Mounting the Disk System	57
24	Door Lock	58
25	LCC Installation	60
26	Setting Enclosure ID	62

27	Wiring Scheme for 1.6 Meter Rack	64
28	Wiring Scheme for 2.0 Meter Rack	65
29	Disk Insertion	67
30	Disk Filler Insertion	68
31	On/Off Button and System LEDs	69
32	Annotate Device Using SAM	78
33	Annotate Device Using STM	79
34	Firmware File Selection Window	80
35	Firmware Download Confirmation Window	81
36	Firmware Tool Window	82
37	Sample Hardware Event Notification	87
38	LED Status Indicators	88
39	Sample Disk System Information Displayed by SAM – Front View	92
40	Sample Disk System Information Displayed by SAM – Rear View	93
41	STM Disk LED Window	112
42	Disk Removal	114
43	Disk Installation	116
44	GBIC Removal and Replacement	119
45	LCC Removal and Replacement	121
46	Enclosure ID and LCC Fault LED	123
47	Fan Removal and Replacement	125
48	Power Supply Removal and Replacement	127
49	Door Lock	128
50	Before and After Disconnecting a Disk System in a Daisy Chain	129
51	Door Removal and Replacement	132
52	Top Cover Assembly	134
53	Mezzanine Assembly	137
54	Backplane Assembly	139

TABLES

1	Inrush (Surge) Current and Duration	36
2	Maximum Operating Current	36
3	Recommended European Circuit Breakers	37
4	Recommended PDU/PDRUs in HP Legacy Racks	38
5	Recommended PDU/PDRUs in HP System/E Racks	39
6	Disk System Accessories	42
7	Disk System Chassis Contents	44
8	Rail Kit A5250A Contents	45
9	Rail Kit A5251A Contents	48
10	Rail Positions for Sequential Disk Systems	52
11	Loop IDs and Hardware Paths by Slot Number and Enclosure ID 0–4	75
12	Loop IDs and Hardware Paths by Slot Number and Enclosure ID 5–9	76
13	LED Functions	89
14	Status Indications	96
15	Troubleshooting Table	99
16	Product Options	142
17	Upgrade Products	143
18	PDU/PDRU Products	144
19	Replacement and Exchange Part Numbers	145
20	Product Weights	147
21	Typical Power Consumption	148

1

PRODUCT DESCRIPTION

General Description

Features

Components

Topologies

Definitions

General Description

The HP SureStore E Disk System FC10 (referred to as the disk system) provides compact, high-speed, high-capacity data storage on ten dual-port Fibre Channel disks. Sixty disks occupy a single Fibre Channel loop; 110 disks (11 disk systems) fill a 2-meter rack. With 9-Gbyte disks, a full 2-meter rack provides .99 Terabytes of storage. With 36-Gbyte disks, the same rack provides 3.96 Terabytes of storage.

Modular and redundant components make the disk system easy to expand and service. Disks, fans, power supplies, and Link Control Cards (LCCs) slide into accessible slots. You can add or remove disks without downtime (system administration required). You can remove and replace redundant fans, power supplies, and LCCs without shutting down the system.

Software utilities, installed on the host, help you manage the disk system:

- System Administration Manager (SAM) provides status and annotation functions.
- Support Tools Manager (STM) includes status, annotation, and firmware download functions.
- Event Monitoring Service (EMS) monitors device status and sends change-of-status messages to user-defined locations.
- HP SureStore E Disk System FC10 Manager (purchased with HP SureStore E SAN Device Management) allows you to check, annotate, and bypass disk system components from any station on the network.

Features

The disk system occupies 3.5 EIA units in a standard 19-inch rack. Disk drives mount in the front of the system. Redundant power supplies, fans, and LCCs mount in the back. A lockable front door shields the environment from RFI and provides access to the disk drives and power button. See Figure 1 on page 18.

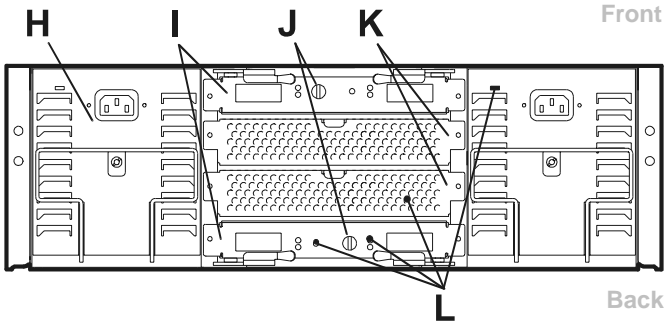
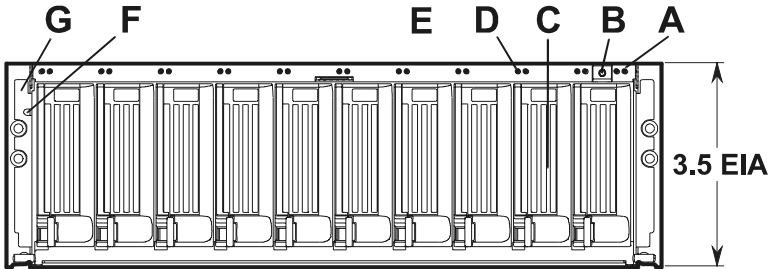
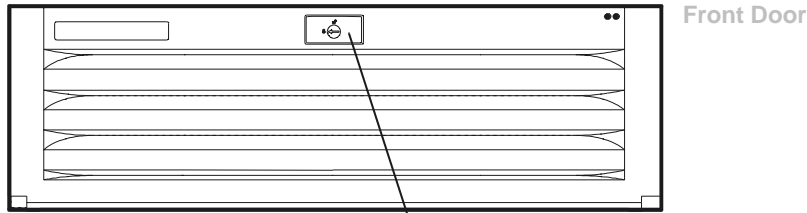

- A system LEDs
- B power button
- C disk drive
- D disk drive LEDs
- E door lock
- F ESD plug
- G mounting ear
- H power supply
- I LCCs
- J Enclosure IDs
- K fans
- L component LEDs

Figure 1 Disk System: Front and Back Views

Status Indicators

LEDs on the front and back of the disk system allow you to detect and replace failed components and prevent or minimize downtime for end users. For additional information about LEDs, see Chapter 4, Troubleshooting.

On the front of the disk system:

- System LEDs (A in Figure 1) indicate that power is on or off and whether or not a fault occurred.
- Disk LEDs (D in Figure 1) indicate whether or not each disk is operating and whether or not a fault occurred.

On the back of the disk system (L in Figure 1):

- A power supply LED indicates that the FRU is operating or a fault occurred
- A fan LED indicates that the FRU is operating or a fault occurred
- The LCC Fault LED indicates whether or not a fault occurred.
- The GBIC Tx Fail LED indicates whether or not the FRU is able to send a signal
- The GBIC Rx Ready LED indicates whether or not the Fibre Channel link is intact.

Power Button

Located in the upper right corner behind the disk system door, the power button (B in Figure 1) turns off the disk system without terminating AC voltage to the power supplies. Power from the AC mains to the power supplies continues unless you unplug the power cords or turn it off at the source.

High Availability

High availability is a general term describing hardware and software systems that are designed to minimize planned and unplanned downtime. The disk system is designed to support Hewlett-Packard's Five Nines initiative, with a target of 99.999% availability. The following disk system features enable high availability:

- Hot-pluggable, high-capacity, high-speed Fibre Channel disks
- Dual Fibre Channel loops to each disk
- Automatic port bypass control and loop recovery
- Redundant, hot-pluggable, and user-replaceable fans, power supplies, and LCCs
- Support for mirrored disks in the HP-UX environment
- Online firmware upgrades
- Remote monitoring and diagnostics
- Hardware event monitoring and real-time error reporting

Upgradability

You can increase storage capacity by:

- Replacing disk drives with higher-capacity disk drives
- Adding disks in unused slots
- Adding another disk system to the loop

None of these actions require shutting down the product, but they may require the use of system utilities to manage data and loop reinitialization.

Disk system and disk firmware can be upgraded through a software download function.

Enclosure Services

LCC enclosure services monitor the following disk system components and communicate their status to a host application:

- Fans
- Power supplies
- Disk drives and slots
- LCCs
- Temperature sensors
- Voltage sensors
- Port bypass

Each LCC provides status and control for all elements in the disk system, even if it does not have direct access to every element.

Additionally, the EEPROM on each LCC stores 2 Kbytes of configuration information and user-defined data, including the manufacturer serial number, World Wide Name, and product number.

Hardware Event Monitoring

The disk system uses Hewlett-Packard's Event Monitoring System (EMS) for HP-UX. An EMS hardware monitor watches the disk system and reports any unusual occurrence, called an event. Hardware event monitoring is an important tool for implementing high availability. Using hardware event monitors, you can virtually eliminate undetected hardware failures that interrupt system operation or cause data loss.

The *EMS Hardware Monitors User's Guide* is included in Adobe® Acrobat® format on the IPR Support Media.

Components

Disk system components provide high availability and easy maintenance. This section describes the following replaceable components:

- Disks
- LCCs
- GBICs
- Fans
- Power supplies

Disks

Disks, shown in Figure 2, are 3.5-inch Fibre Channel disks in a metal carrier. The open carrier design allows 10 Half Height (1.6 inch) disks to fit the width (19 inches) of a standard rack and meet cooling needs. Exposed disks require careful handling to avoid damage by breakage and static electricity, and to prevent personal harm by contact with hot surfaces and static electricity.

WARNING **Touching exposed circuits can cause electrical discharge and disable the disk. Disks require careful handling and ESD precautions.**

The plastic parts of the disk are safe to touch:

- Bezel-handle (A in Figure 2)
- Cam latch (B)
- Insertion guide (F)

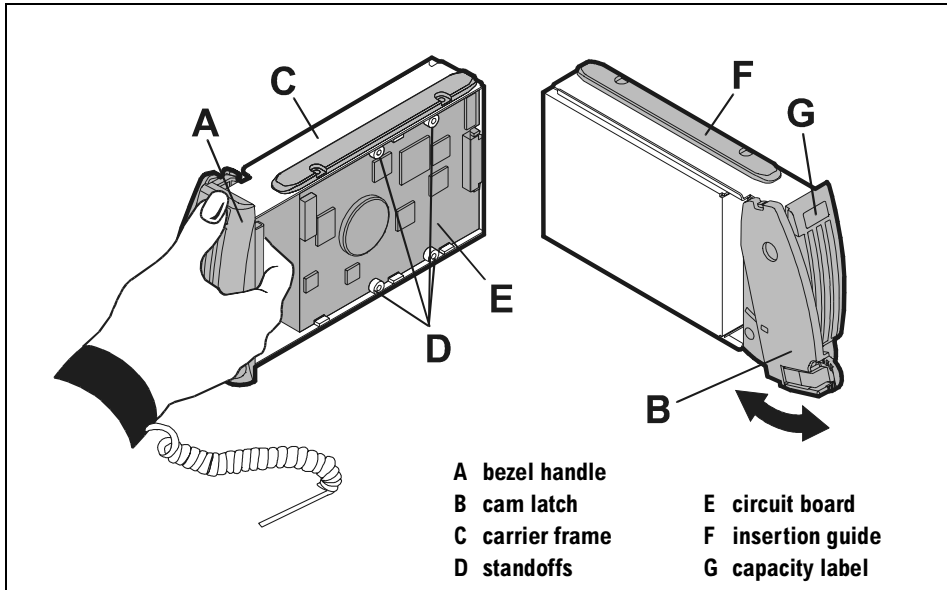

Figure 2 Disk

Metal standoffs (D) protect exposed circuits against damage when the disk is laid circuit-side down on a flat surface.

Disks fit tightly in their slots. The cam latch (B) uses mechanical advantage to seat and unseat the connectors on the backplane.

A label (G) shows the disk height, rotational speed, and storage capacity when the disk is installed. You will see the following values:

- Height: 1.6 inch (Half Height) or 1 inch (Low Profile)
- Rotational speed: 10 K
- Capacity: 9.1 Gbyte, 18.2 Gbyte, or 36.4 Gbyte

LCCs

Each LCC provides two ports on one of the redundant internal loops. The Primary Port (B in Figure 3) connects the disk system to the external Fibre Channel loop through a host, hub, or another disk system. The Expansion Port (E) connects to the Primary Port of another disk system for daisy-chain configurations. When both LCCs are connected to a host or hub, both internal loops are active and the LCCs are hot-pluggable.

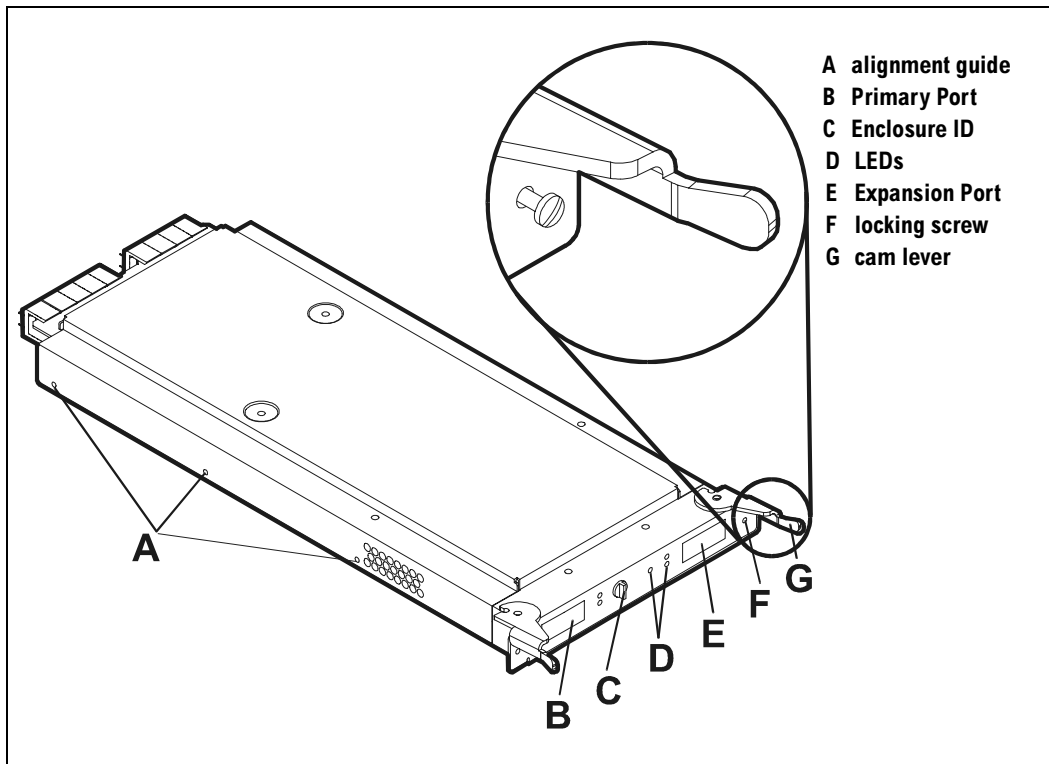

Figure 3 LCC

Other LCC features include:

- Cam levers (G) that help push the LCC in and out of its connection on the backplane
- LEDs (D) that show the status of the LCC and each of the port connectors (GBICs)
- Screws (F) that prevent the card from being disconnected unintentionally
- The Enclosure ID (C), which determines the loop ID of the LCC and disk drives. The dial must be set to the same number on both LCCs.

LCC functions include port bypass control, enclosure services, drive addressing, and fault detection. Port bypass circuits maintain the loop when a port is physically removed or empty. For an explanation of enclosure services, see page 21.

GBICs

GBICs equip Primary and Expansion Ports for Fibre Channel cables, in this case, for fiber optic cables. If a GBIC fails or a product upgrade supports other physical media, you can replace the GBIC without replacing the LCC. GBICs are hot-pluggable.

GBICs differ in appearance and locking mechanism. Figure 4 shows the general characteristics of a GBIC.

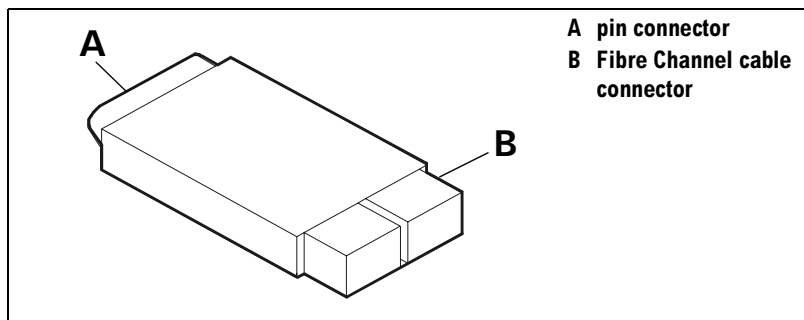

Figure 4 GBIC

Fans

Redundant, hot-pluggable fans blow cooling air over system components. Each fan has two internal high-speed blowers (A in Figure 5), an LED (B), a pull tab (C), and two locking screws (D).

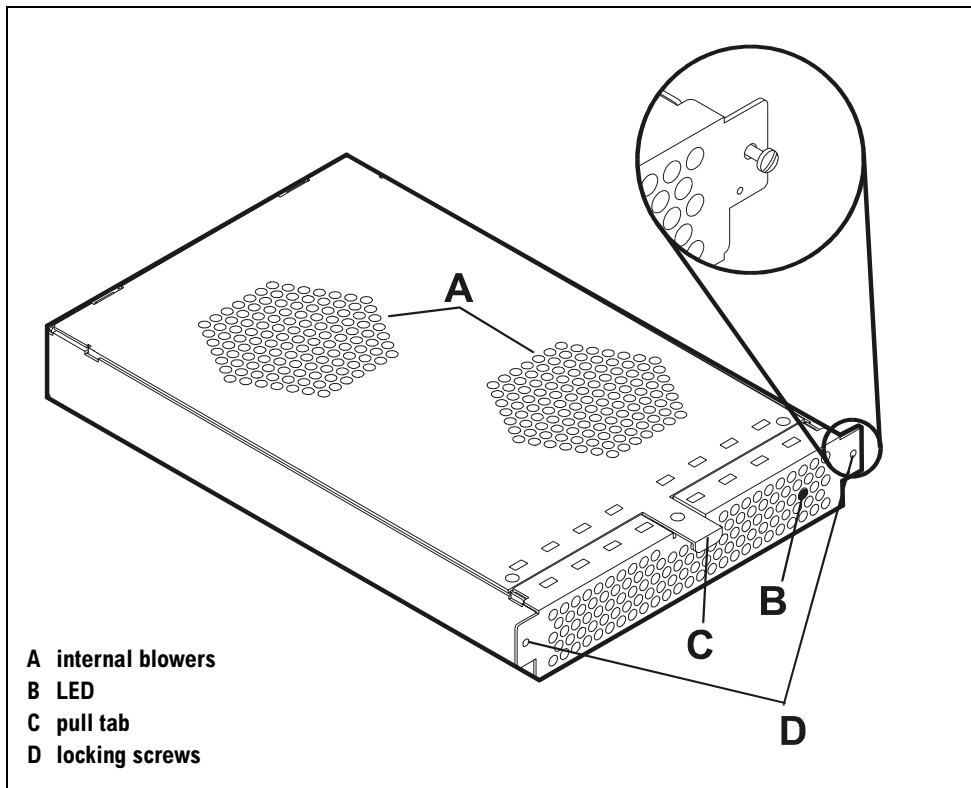

Figure 5 Fan

Internal circuitry senses blower motion and triggers a fault when the speed of either blower falls below a critical level. At the same time, the LED turns amber, and, if enabled, the hardware event monitor sends an event message.

Power Supplies

Redundant, hot-pluggable 450-watt power supplies convert wide-ranging AC voltage from an external main to stable DC output and deliver it to the system backplane. Each power supply has two internal blowers, an AC receptacle (A in Figure 6), a cam handle (B) with locking screw, and an LED (C). Internal control prevents the rear DC connector from becoming energized when the power supply is removed from the product.

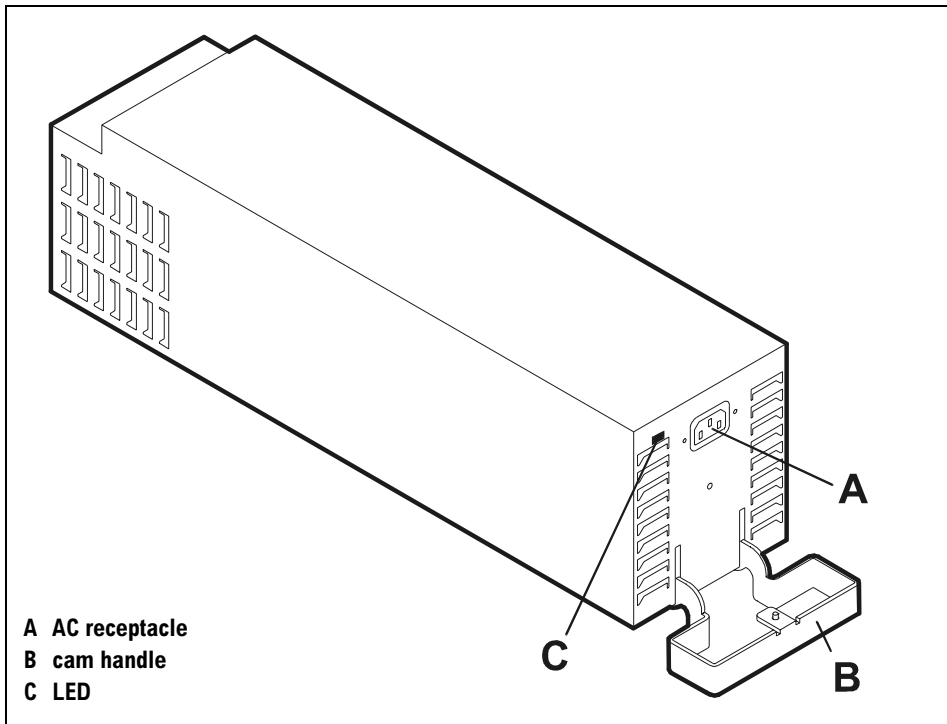

Figure 6 Power Supply

Power supplies share the load reciprocally; that is, each supply automatically increases its output to compensate for reduced output from the other, and vice versa. If one power supply fails, the other delivers the entire load.

Internal circuitry triggers a fault when an internal fan or other part fails. At the same time, the LED turns amber, and, if enabled, the hardware event monitor sends an event message. Power supply fans remain on if other parts fail in order to maintain cooling air flow through the system. If a fan fails, the power supply shuts down.

Topologies

The disk system supports high availability in various configurations. Redundant loops can be connected to separate adapters in the same or different hosts. Connecting both loops to a hub provides redundancy, and connecting each loop to a separate hub provides a higher degree of redundancy. There is much flexibility in the way you can integrate disk systems in a data center.

A few basic topologies are described on the following pages. For current information about supported topologies, consult an HP sales representative.

Redundant Hubs on Redundant Servers

Redundant loops of multiple disk systems can be connected to separate 10-port FC-AL shortwave hubs (HP A3721A/AZ), which are on separate host/servers. See Figure 7. All connections are optical.

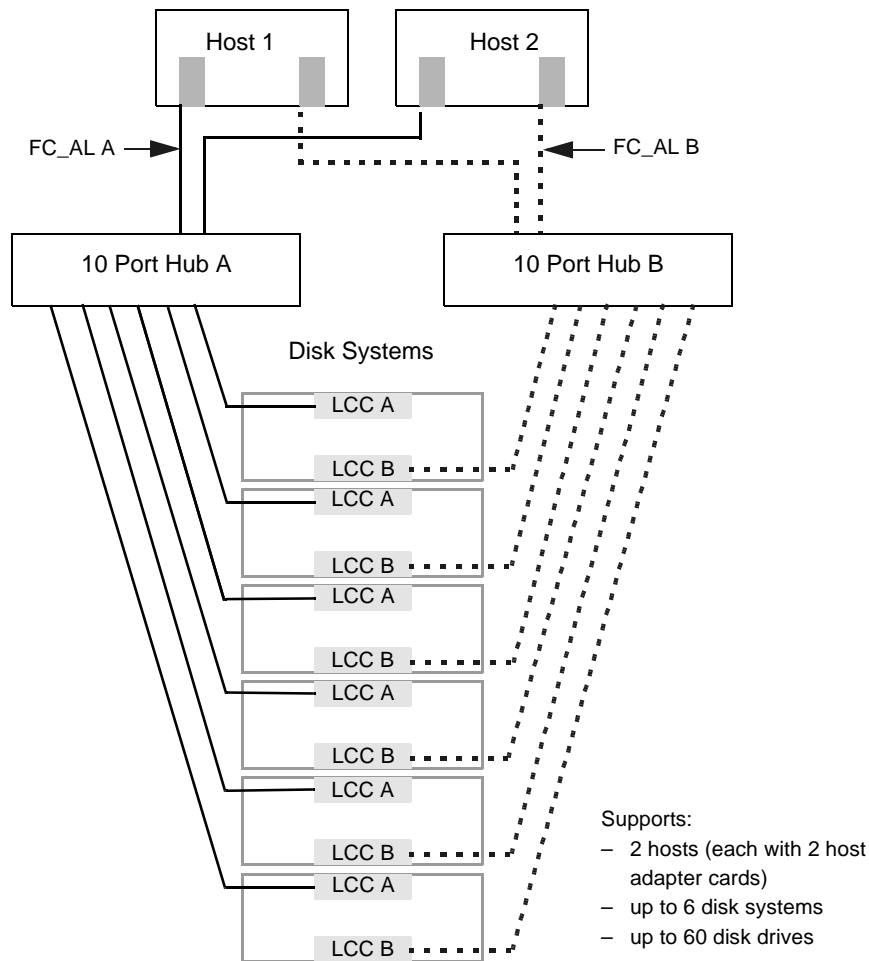

Figure 7 Redundant Hubs on Redundant Host/Servers

No-Hub Configuration

Connecting disk systems to redundant adapters is one way to achieve high availability. In Figure 8, each adapter card can reach any disk system through one of two paths. Disk systems are daisy-chained on redundant loops.

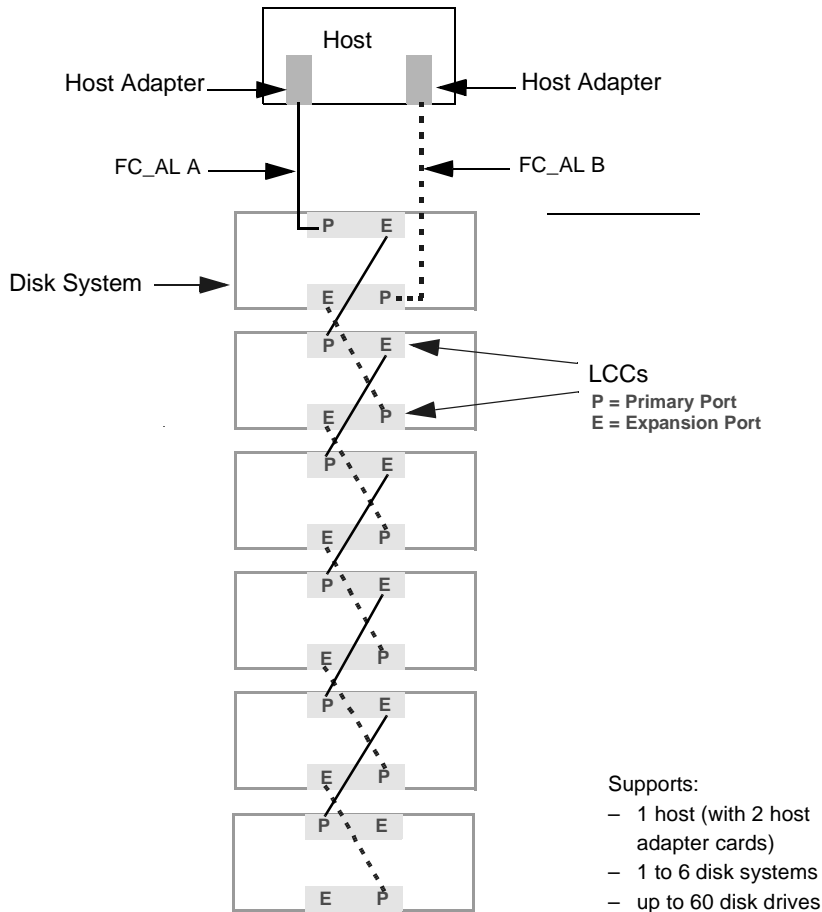

Figure 8 Redundant Adapters on One Server

Long-Wave Hub Configuration

The long-wave hub configuration (Figure 9) maximizes disaster recovery through mirrored systems on remote sites. Redundant loops of multiple disk systems are connected to redundant long-wave hubs on redundant servers. In addition, each hub is connected by its long-wave port to another remote hub, which is connected to another server and more disk systems.

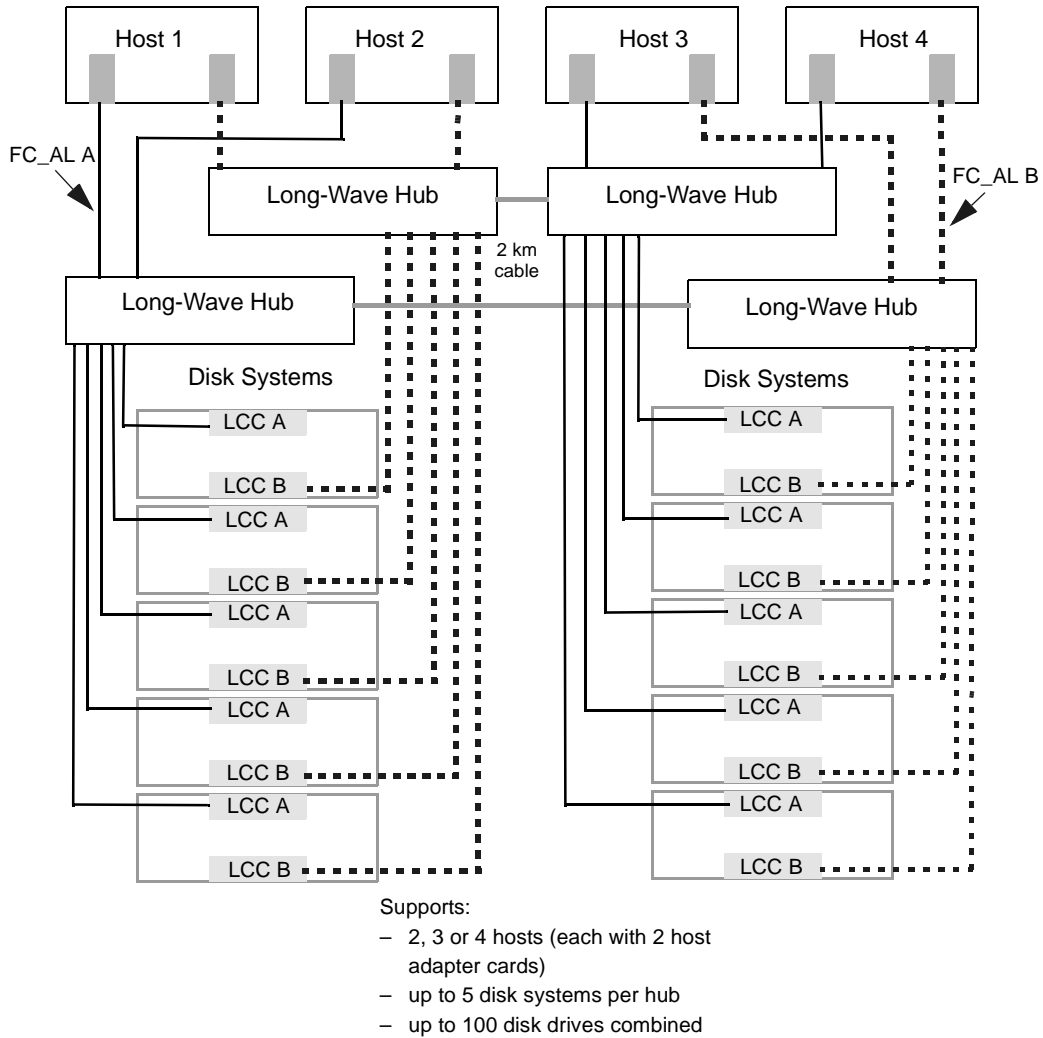

Figure 9 Redundant Adapters on Four Servers

Definitions

The following terms are specifically defined for the purposes of this manual:

high availability (HA)

HA describes hardware and software systems that are designed to maximize planned and unplanned downtime. The disk system supports Hewlett-Packard's High Availability Initiative, which specifies system-level availability in phases: 99.8% (18 hours downtime per year) today and 99.999% (5 minutes downtime per year) by 2001.

hot-pluggable

Hot-pluggable signifies the ability of a component to be installed or replaced without interrupting storage operations and within the restrictions of the operating environment. Most disk system components can be replaced under power. Adding or replacing disks, LCCs, and GBICs may require the use of HP-UX commands or SAM to manage file systems.

PDU and PDRU

PDUs (power distribution units) distribute power from a single inlet to multiple outlets. PRUs (power relay units) connect one or more PDU inlets to a single on/off switch, such as a cabinet switch. Units that both distribute and switch power are referred to as PDRUs.

Electrical Preparation

Tools

Step 1: Unpack the Product

Step 2A: Install Rails (for Legacy Racks)

Step 2B: Install Rails (for System/E Racks)

Step 3: Prepare Rack Front

Step 4: Mount the Disk System

Step 5: Install GBICs and LCCs

Step 6: Set the Enclosure ID

Step 7: Connect Fiber Optic and Power Cables

Step 8: Install Disks and Fillers

Step 9: Turn on the Disk System

Electrical Preparation

Before installing the disk system, make sure the environment is equipped to meet power needs.

Electrical Requirements

All electrical wiring to the service point (plug) must be sized to carry the following inrush and steady state currents.

Table 1 Inrush (Surge) Current and Duration

No. of Disk Systems on Circuit	Inrush Currents and Duration
1	Up to 20 amps for 10 to 12 milliseconds
2	Up to 40 amps for 10 to 12 milliseconds
3	Up to 60 amps for 10 to 12 milliseconds
4	Up to 80 amps for 10 to 12 milliseconds

Table 2 Maximum Operating Current

Incoming Voltage AC RMS	Maximum RMS Current Drawn by One Disk System
100 – 120 volts	5.3 – 6.5 amps
200 – 240 volts	2.6 – 3.2 amps

Caution Multiple disk systems are not recommended on 110 V circuits. The combined current drawn by multiple systems quickly exceeds 110-V capacity.

Hewlett-Packard recommends magnetic-type circuit breakers, which are capable of handling large inrush currents for short durations (10 to 12 milliseconds) and are rated adequately for steady state currents.

Table 3 Recommended European Circuit Breakers

No. of Disk Systems*	Breaker Rating	Breaker Type
1 to 3	16 amps	Type C or Type D per IEC 898 or Type K per IEC 947-2
4	16 amps	Type D per IEC 898 or Type K per IEC 947-2

* Data assumes no other devices share the circuit breaker.

Note Circuit breaker rating must be adequate for the total current drawn by all devices on all electrical paths that share a circuit breaker.

Choosing PDUs

Peak power requirements and PDU capacity affect the number of disk systems that can be installed in a rack. For example, to install more than four disk systems in Hewlett-Packard legacy racks (HP C2785A, C2786A, C2787A, A1896A, or A1897A), you must upgrade 3-foot and 5-foot PDUs to 19-inch PDUs.

Besides rack density, the following factors can help you choose PDUs:

- **Redundant power source.** To connect redundant power supplies to separate PDUs, install redundant PDUs.
- **Number of cords to the AC source.** Using 30-amp PDRUs instead of 16-amp PDUs reduces the number of cords to the wall.

- **Future needs.** Installing surplus PDU capacity allows you to add disk systems later.
- **Inrush margins.** For installations that require four or more 16-amp PDUs, Hewlett-Packard recommends HP 30-amp PDRUs (E7681A, E7682A) for their inherent inrush protection.
- **On/Off switch support.** Some PDU/PDRU options support the use of a single-point on/off switch. See Table 4 and Table 5.

The following tables show recommended PDU/PDRU combinations for one or more disk systems in a rack. Data assumes 220V AC nominal power and redundant PDU/PDRUs. For nonredundant configurations, divide the number of recommended PDU/PDRUs by 2.

Table 4 Recommended PDU/PDRUs in HP Legacy Racks

No. of Disk Systems	1.1 meter (21 U)	1.6 meter (32 U)	2.0 meter (41 U)
1 – 4	2 3-foot/16-amp PDUs* <i>or</i> 2 19-inch/16-amp PDUs	2 5-foot/16-amp PDUs* <i>or</i>	2 19-inch/16-amp PDUs
5 – 8	NA**	2 19-inch/30-amp PDRUs	
9 – 10	NA**	NA**	4 19-inch/30-amp PDRUs

* Supports cabinet on/off switch.

** Rack height does not allow additional disk systems.

Table 5 Recommended PDU/PDRUs in HP System/E Racks

No. of Disk Systems	1.25 meter (25 U)	1.6 meter (33 U)	2.0 meter (41 U)
1 – 4	2 19-inch/16-amp PDUs <i>or</i> 2 19-inch/30-amp PDRUs*		
5 – 8	NA**	2 19-inch/30-amp PDRUs*	
9 – 11	NA**	NA**	4 19-inch/30-amp PDRUs

* Supports the cabinet on/off switch option.

** Rack height does not allow additional disk systems.

Installing PDUs

The 19-inch PDUs and PDRUs can be installed vertically or horizontally in the rack. Choose PDU/PDRU locations with the following guidelines in mind:

- Place PDU/PDRUs within the reach of disk system cords.
- Place PDU/PDRUs vertically whenever possible. See sample installations on page 40 and page 41. Installing PDU/PDRUs horizontally interferes with the ability to service disk systems behind the PDU/PDRU.
- Place vertical PDU/PDRUs on each side of the disk system so that the cord from either power supply does not cross over replaceable components in the middle of the product.
- Thirty-amp PDRUs must be installed directly behind the disk system to achieve the highest densities in 2-meter racks. (See Figure 11 on page 41.) Hinged brackets allow Hewlett-Packard's 30-amp PDRUs (HP E7681A and E7682A) to swing aside for servicing hidden disk systems.

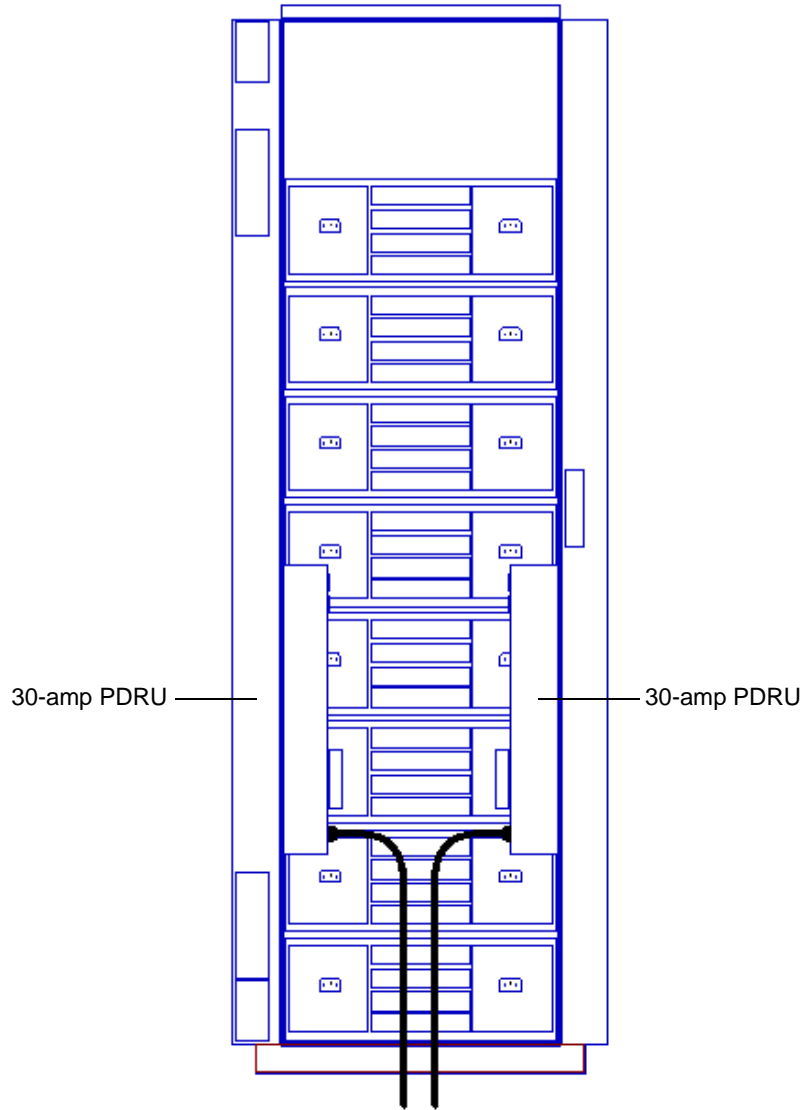

Figure 10 PDU Placement in 1.6 Meter Rack

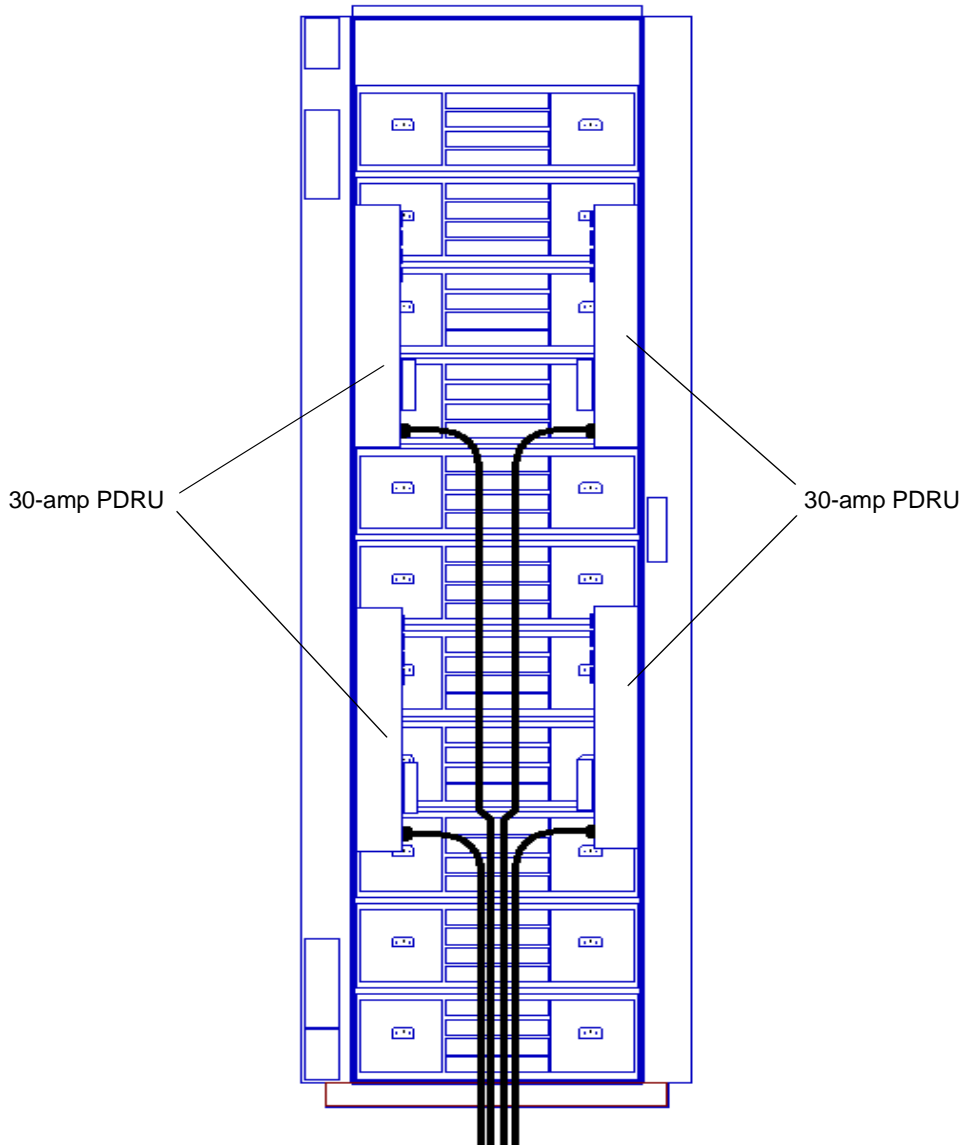

Figure 11 PDRU Placement in 2.0 Meter Rack

Tools

- Torx T25 screwdriver
- Torx T15 screwdriver
- Small flat-blade screwdriver

Step 1: Unpack the Product

1. Lift off the overcarton and verify the contents of the accessories (top) box. See Table 6 and Figure 12.

Table 6 Disk System Accessories

Figure

Label	Part (part number)
A	User Guide (A5236-90001)
B	Quick Install poster (A5236-90015)
C	ESD strap (9300-2170)
D	Rack filler panel (5183-6369)
E	Two or more GBICs (A5245A)
F	Two LCCs (A5244-60001)
G	Rail kit for legacy racks (A5250A)
H	Rail kit for Rack Systems/E (A5251A)
I	Pack of 4, 8, or 10 disks (A5234A, A5235A, or A5596A)
J	Disk fillers

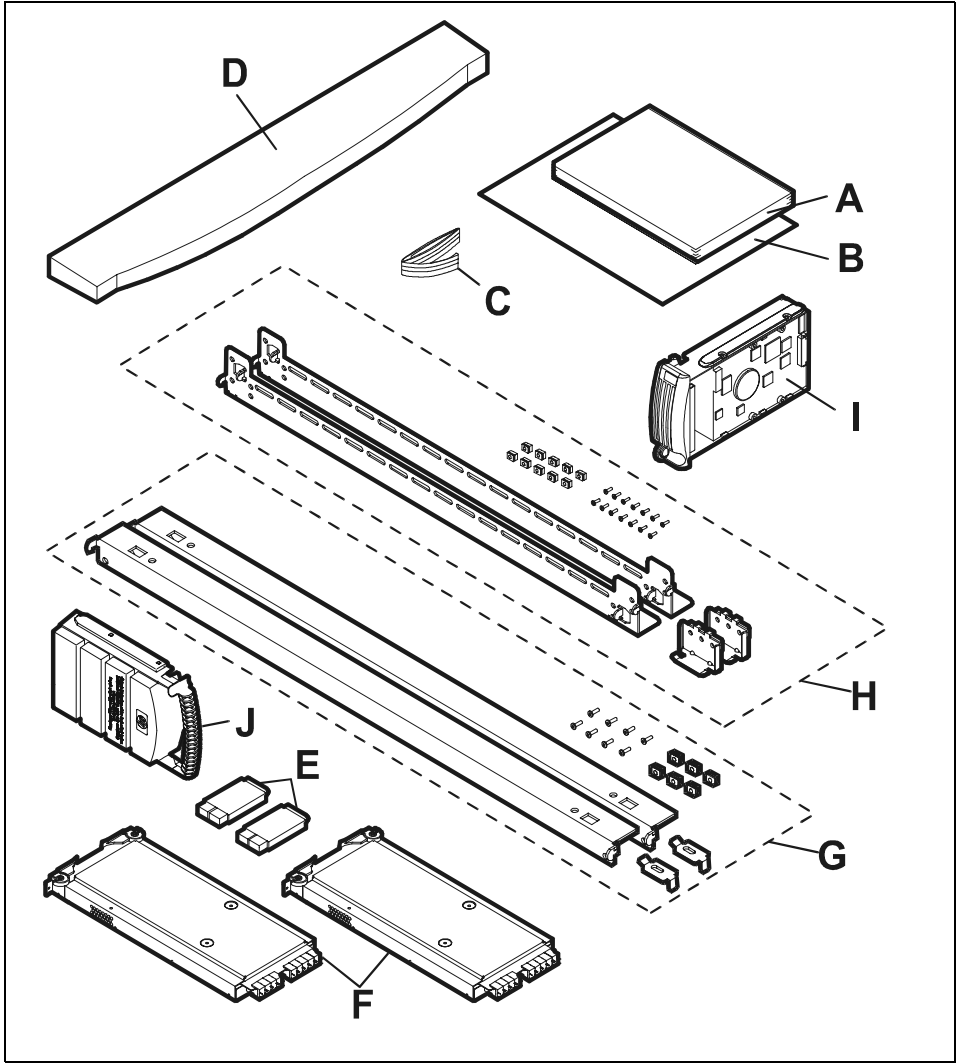

Figure 12 Disk System Accessories

2. Lift off the top of the chassis (bottom) box and verify the following contents.

Table 7 Disk System Chassis Contents

Figure

Label Part (part number)

A	Disk system chassis with pre-installed fans and power supplies
B	Two power cords (8120-6514)

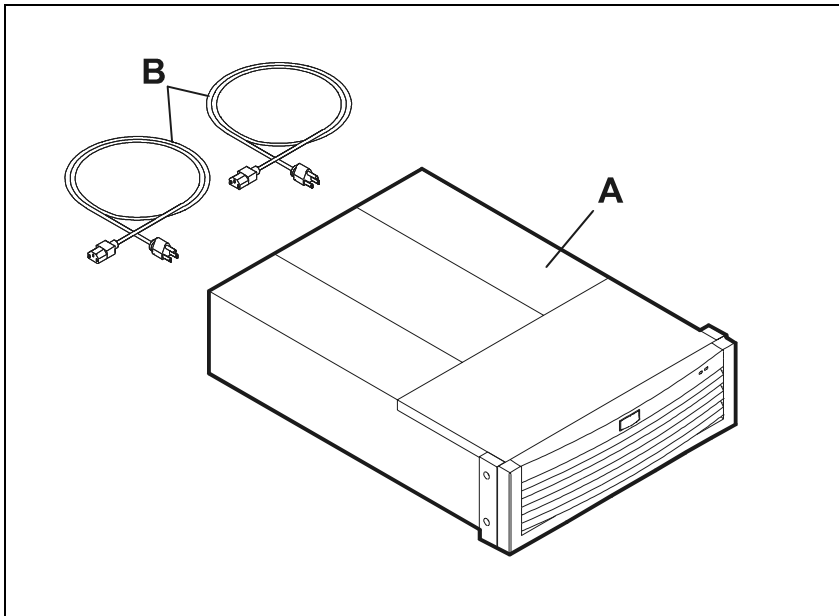

Figure 13 Disk System Chassis Contents

3. If parts are missing, contact an HP sales representative.

Step 2A: Install Rails (for Legacy Racks)

If you are installing the disk system in HP rack products C2785A, C2786A, C2787A, A1896A, or A1897A, use rail kit HP A5250A and complete this step. For other HP racks, refer to Step 2B.

1. Unpack the rail kit and verify the following contents:

Table 8 Rail Kit A5250A Contents

Label	Part
A	2 rails
B	2 rail clamps
C	8 M5 16mm screws
D	6 sheet metal nuts
E	Rack Mount Guide

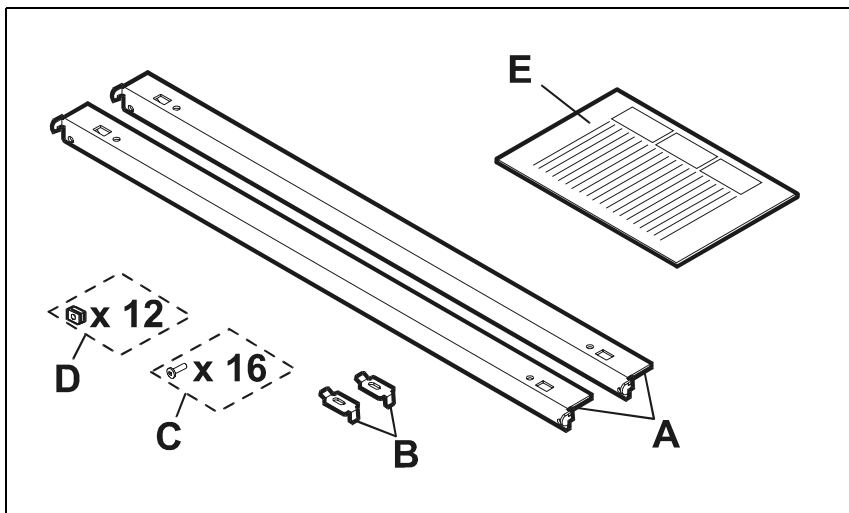

Figure 14 Rail Kit A5250A Contents

If a part is missing, contact an HP sales representative.

2. Select racking location(s) and install sheet metal nut(s) on one column.

The disk system consumes 4 EIA Units (U) in an HP legacy rack, 3.5 for the product and .5 for the rail. Select an empty space 4 U high and install a sheet metal nut (B in Figure 15) opposite the bottom slot (A).

If you are installing multiple disk systems, install sheet metal nuts at every fourth slot (every 12 holes) on the column.

3. Install sheet metal nuts on the other three columns at the same height(s) installed on the first column.

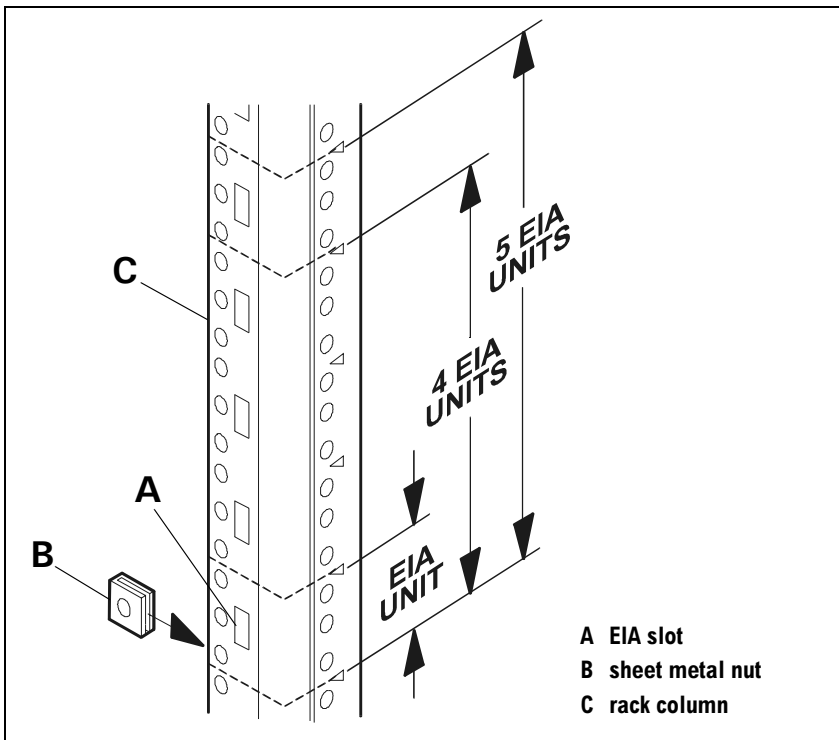

Figure 15 Rack Column Detail – Legacy Racks

4. Attach rails to rack.

- a. Insert rail tabs into the selected slots on the right front and back columns. Make sure that the rail is level and that rail holes align with the sheet metal nuts (C in Figure 16) you just installed on the rack column.
- b. Insert one screw (B) through the rail (A) and prepared column holes (C). Tighten screws with a Torx T25 screwdriver.
- c. Repeat steps a. and b. on the left side of the rack.

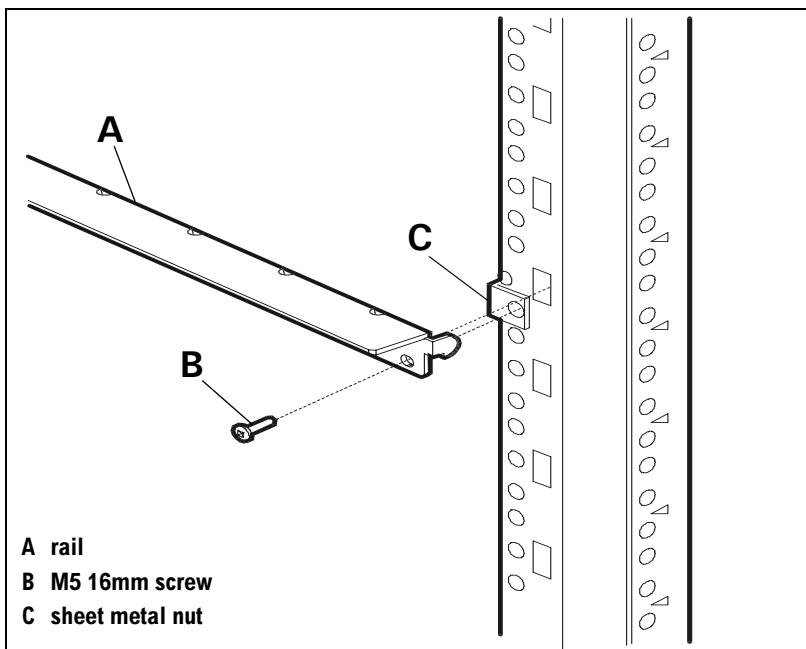

Figure 16 Rail Assembly – Legacy Racks

Step 2B: Install Rails (for System/E Racks)

If you are installing the disk system in an HP Rack System/E, use rail kit HP A5251A and complete this step. For other HP racks, see Step 2A.

1. Unpack the rail kit and verify the following contents (Table 9 and Figure 17).

Table 9 Rail Kit A5251A Contents

Figure

Label	Part
A	2 rails
B	2 rail clamps
C	14 M5 16mm screws
D	10 sheet metal nuts
E	Rack Mount Guide and Template

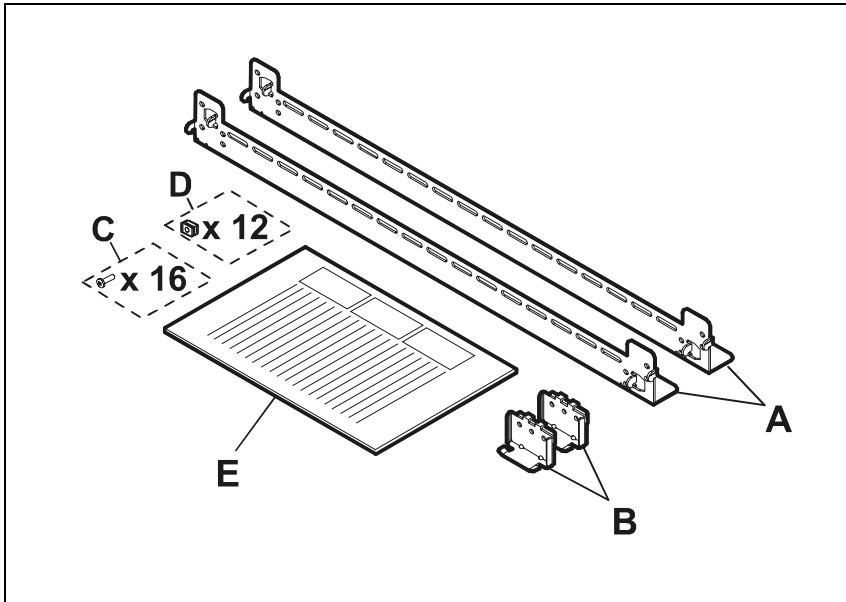

Figure 17 Rail Kit A5251A Contents

If a part is missing, contact an HP sales representative.

-
2. Select racking location(s) and set rail(s) on the right front and back columns.

In a Rack System/E, the rails do not add height and each disk system consumes only 3.5 EIA Units (U). (EIA Units are numbered on the column.) Select an empty 3.5 U in the rack and set the rail at the bottom as follows:

- To set rails at the EIA Unit number, insert the lower rail tabs (C in Figure 18) in the bottom EIA slot (B).
- To set rails between EIA Units, use the upper rail tabs (C in Figure 19) in the next EIA slot (B).

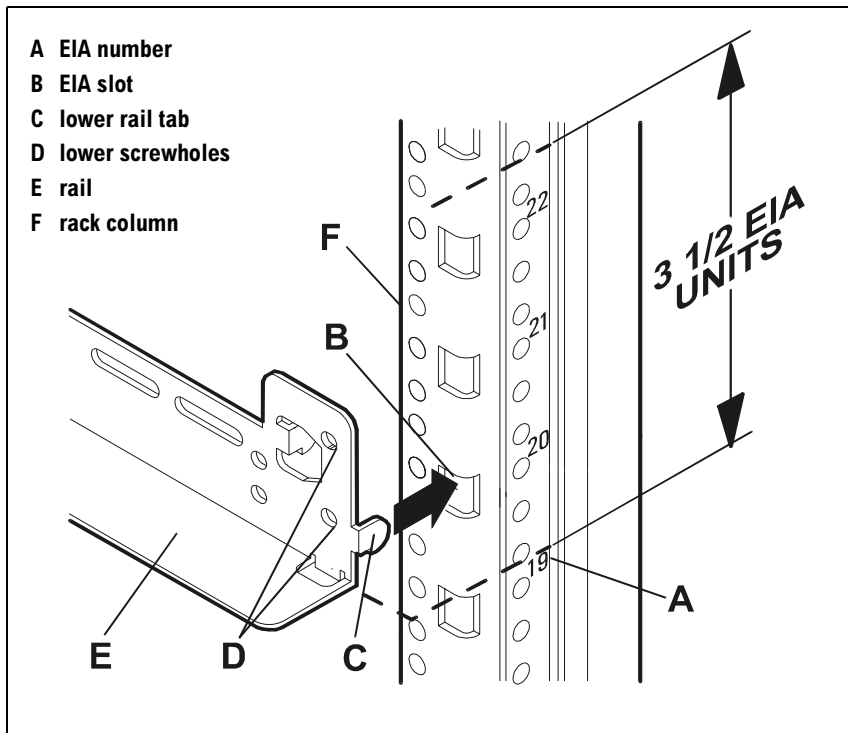

Figure 18 EIA Unit Rail Position

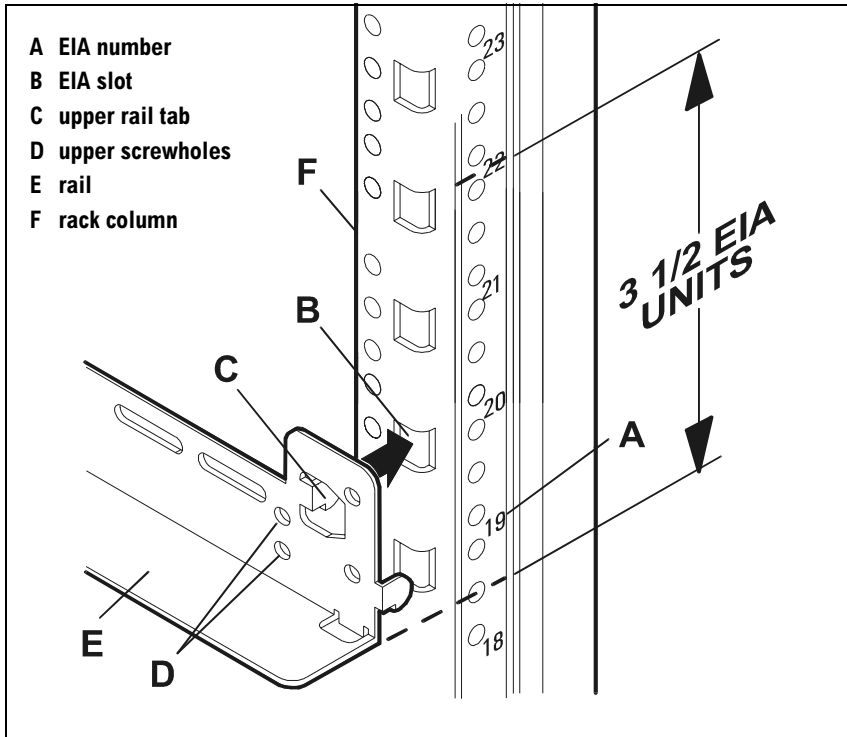

Figure 19 Mid-EIA Unit Rail Position

Note Properly installed rails sit at different depths on the right and left sides of the rack.

To install additional disk systems without gaps, alternate rails between the full and mid-EIA positions, 3 and 4 EIA Units apart, respectively. For example,

starting at the bottom of a 2-meter rack, install rails at the following EIA locations:

Table 10 Rail Positions for Sequential Disk Systems

Disk Systems	EIA Unit	Using
One	0	lower tab in slot 0
Two	between 3 and 4	upper tab in slot 4
Three	7	lower tab in slot 7
Four	between 10 and 11	upper tab in slot 11
Five	14	lower tab in slot 14
Six	between 17 and 18	upper tab in slot 18
Seven	21	lower tab in slot 21
Eight	between 24 and 25	upper tab in slot 25
Nine	28	lower tab in slot 28
Ten	between 31 and 32	upper tab in slot 32
Eleven	35	lower tab in slot 35

3. Set corresponding rail(s) on the left columns at the same height(s) selected on the right columns.

Note Be sure to use the same—upper or lower—tab on opposite rails.

Consecutive sets of rails have alternating tab positions and alternating left and right depths in the rack.

4. Install sheet metal nuts (C in Figure 20) at the rail location(s) on all four columns.

Using the rail (B) to identify matching holes in the rack column, slide two sheet metal nuts (C) on each column (D). Lift the rail away from the column, if needed, to insert the nuts.

Note Holes vary for upper and lower positions at opposite ends of the rail.

5. Insert two screws (A in Figure 20) through each rail end and prepared rack column. Use a Torx T25 screwdriver to tighten the screws securely.

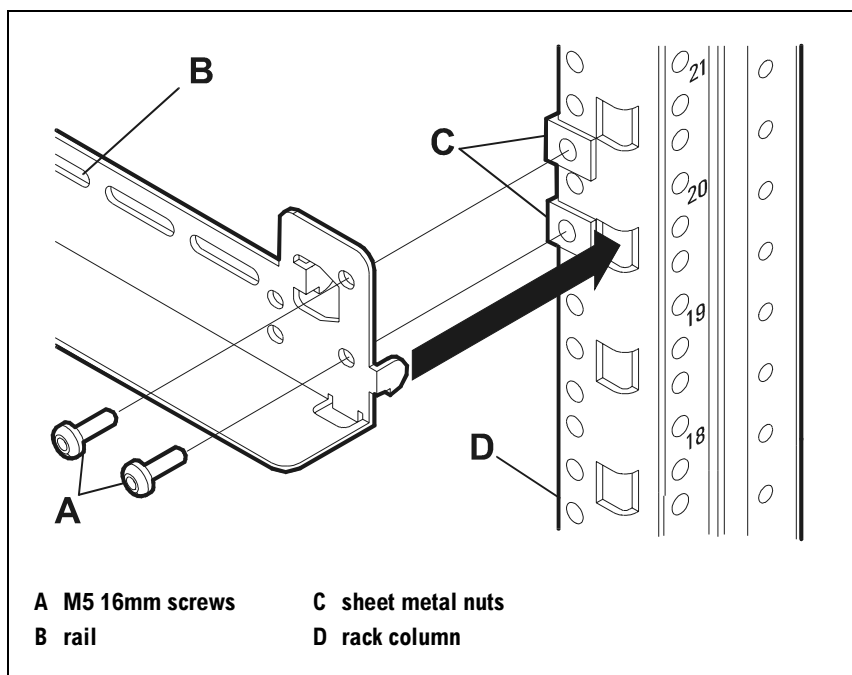

Figure 20 Rail Assembly – Rack Systems/E

Step 3: Prepare Rack Front

Install one sheet metal nut each on the right and left front columns as follows:

- In legacy HP racks, count six holes (4 inches) up from the bottom of the installed rails.
- In HP Rack Systems/E:
 - If the bottom of the rail (A in Figure 21) is at the EIA Unit number, count six holes up and install the sheet metal nut.

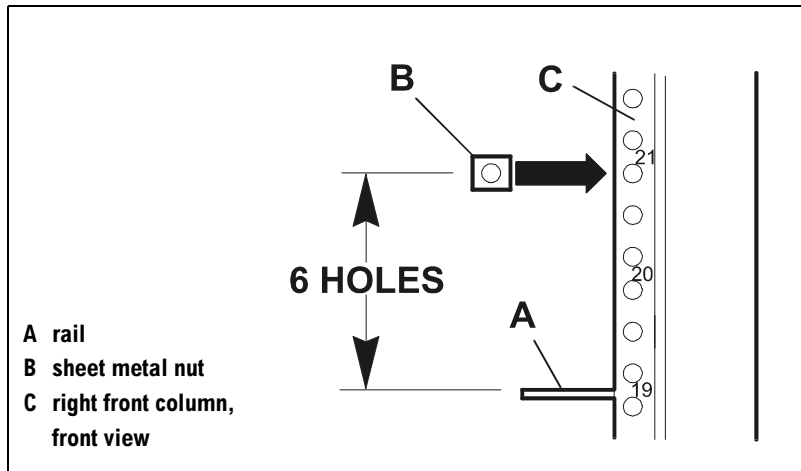

Figure 21 Rack Front Preparation: EIA Unit Rail Position

- If the rail (A in Figure 22) falls in the middle of an EIA Unit, count seven holes up from the bottom of the rail and install the sheet metal nut.

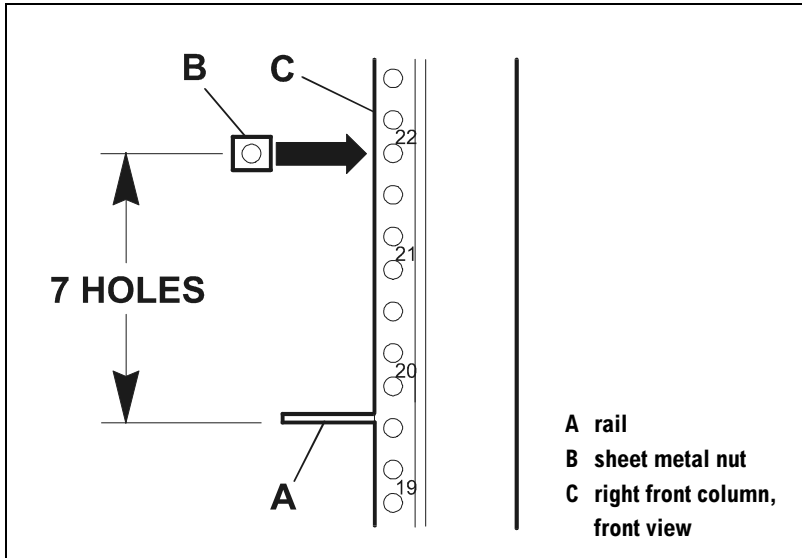

Figure 22 Rack Front Preparation: Mid-EIA Unit Rail Position

Note

If you do not install these nuts correctly now, you will have to remove the disk system to install them later.

Step 4: Mount the Disk System

Caution Do not try to lift the disk system using the handles on the power supplies.

1. (Optional) Remove the power supplies to prepare the disk system for lifting:
 - a. With the chassis still in the box, loosen the screw in the handle of each power supply.
 - b. Pull the cam handle down to disengage the power supply from the backplane and pull each power supply out of the chassis. Support the far end of the supply with your free hand as it clears the chassis.
 - c. Set the power supplies aside to be reinstalled later.

WARNING Do not attempt to lift the disk system without the help of another person or a lift device. Even without power supplies, it weighs 50 pounds.

2. With another person or using a lift device, lift the disk system and slide it, back-end first, into the front of the rack and onto the previously installed rails (Figure 23). Push the disk system as far into the rack as it will go.

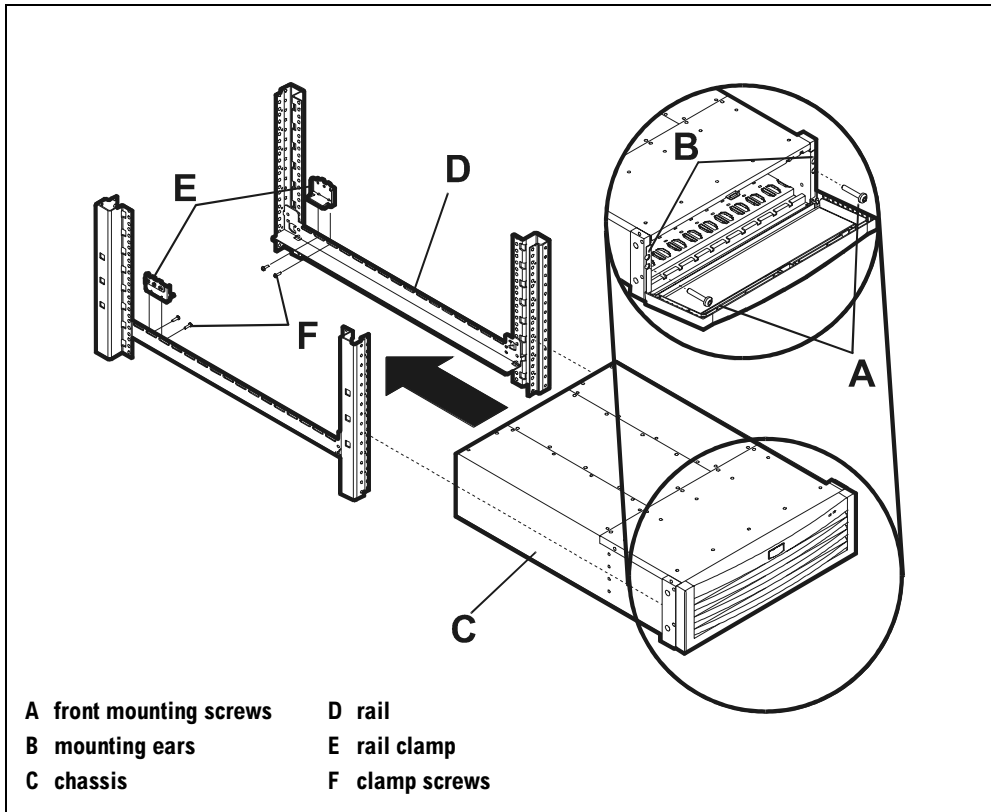

Figure 23 Mounting the Disk System

Caution To protect the door, do not lift or move the disk system with the door open.

-
3. Unlock and open the disk system door, using a thin flat-blade screwdriver to turn the lock (Figure 24).

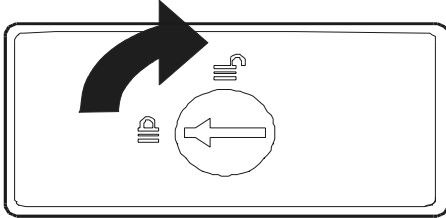

Figure 24 Door Lock

4. Verify that one hole in each mounting ear (B in Figure 23) aligns with the sheet metal nuts previously installed on the rack front columns. Depending on the rail position, the lower or upper set of holes will align with the rack front holes.

Note If you need to reinstall front nuts, use the extra sheet metal nuts provided.

5. Insert two screws (A in Figure 23) through the matching holes in the disk system mounting ears and rack front columns. Tighten screws.
6. Close the door.
7. Fasten the back of the disk system to the rails using the clamps from the rail kit.

In legacy racks:

- a. Align screw holes and insert the clamp tab into the slot in the upper surface of the rail.
- b. Insert a screw through the hole in the clamp and the rail and tighten with a Torx T25 screwdriver.

In Rack Systems/E:

- a. Set the clamp (E in Figure 23) inside the rail with the holes in the clamp along the slots in the rail.
 - b. Push the clamp tight against the back of the disk system. The curved tip of the clamp should overlap the bottom edge of the power supply slot.
 - c. Insert and tighten two M5 16mm screws (F in Figure 23) through each clamp and rail.
8. Reinstall power supplies removed in Step 1.
 9. Install half-EIA Unit rack filler panel(s) as needed. A half-EIA Unit gap exists between products in original HP racks and when an odd number of disk systems are installed in the Rack System/E.

Step 5: Install GBICs and LCCs

GBICs (Giga-Bit Interface Converters) (A in Figure 25) prepare LCC ports for Fibre Channel cables. In these instructions, you install them before installing the LCC. LCCs (D) fit in reversed positions into the top and bottom slots (H) in the back of the disk system. Both LCCs fit either slot and both must be installed.

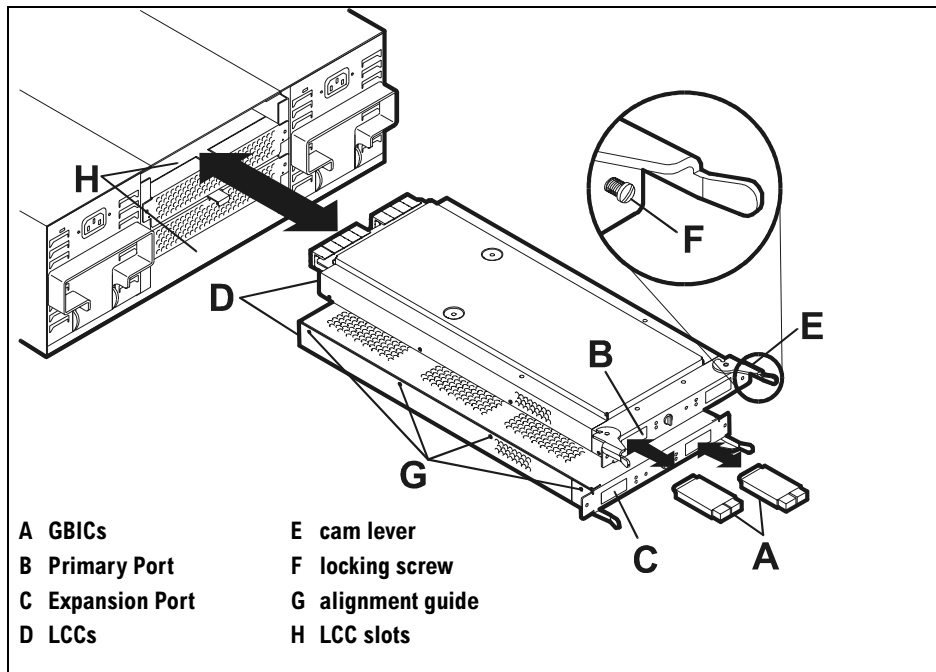

Figure 25 LCC Installation

-
1. Unpack the LCCs and GBICs from the accessories box.
 2. Insert a GBIC, pin-end first, into the Primary Port (B) of each LCC. Depending on the type, the GBIC will click into place or you need to close the bail on the cable end to lock in the GBIC.

Note GBICs are required in the Primary Ports, optional in the Expansion Ports.

3. If you plan to connect another disk system to this one, insert a GBIC into the Expansion Port (C) of each LCC.

Caution Do not touch the pins on the back of the LCC.



4. Open the LCC cam levers (E) by pulling them away from the center.
5. Aligning the guides (G) in the sides of the LCC with the notches in the edges of the slot, insert the LCC completely into the slot.

Note In the top slot, the LCC cam levers are on top. In the bottom slot, the cam levers are on the bottom.

6. Push the cam levers inward and flat against the center to fully seat the LCC.
7. Use a Torx T15 or flat-blade screwdriver to tighten the locking screws (F).

Step 6: Set the Enclosure ID

Turn the dial (A in Figure 26) on both LCCs to a number between 0 and 9. The number must be the same on both LCCs, and it must be different from the setting of any other disk system in the same loop.

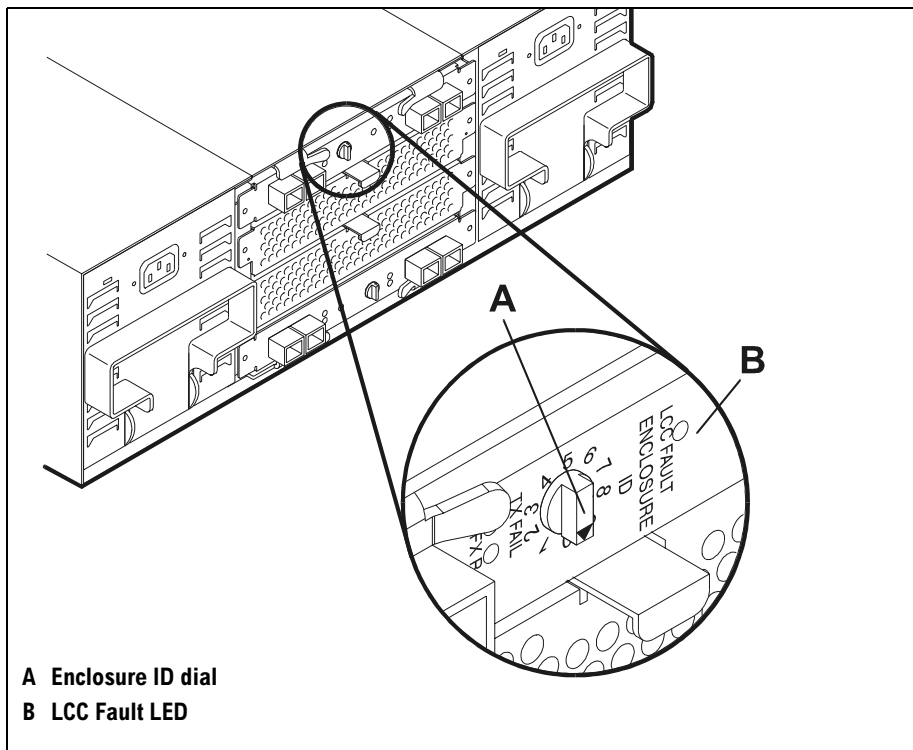

Figure 26 Setting Enclosure ID

Step 7: Connect Fiber Optic and Power Cables

1. Attach one end of a fiber optic cable to the GBIC in the Primary Port of each LCC.
2. Attach the other end of each fiber optic cable to a hub, host adapter, or the Expansion Port of another disk system, as determined by the site. (See the internal document *HP 9000 Enterprise Servers Configuration Guide* for current supported configurations.)

Note The Primary Ports on the two LCCs must be directly or indirectly connected to different adapters in order to enable redundant loops to the disks.

3. Plug a power cord into the AC receptacle of each power supply.
4. Attach the other end of each power cord to a pre-installed PDU/PDRU. Choose outlets according to the following guidelines:
 - **Redundancy.** To extend the redundancy of the product, attach each cord to a different PDU. This is represented in Figure 27 and Figure 28 by the absence of duplicate letters in each disk system.
 - **Reliability.** To avoid cascading faults for a group of disk systems that are plugged into the same PDU, distribute the redundant power cords among different PDUs. This is represented in Figure 27 and Figure 28 by the minimum number of duplicate pairs of letters among all disk systems. “Cascading” refers to overload faults that occur on a backup PDU as a result of power surges after the primary PDU fails.
 - **Serviceability.** Choose PDU locations that prevent power cords from interfering with the removal and replacement of serviceable components. Also leave a 6-inch service loop to allow for the rotation of PDRUs.

The letters A, B, C, D, E and F in the following diagrams represent independent PDUs or PDU banks. The absence of duplicate letters in individual disk systems indicates the products are using redundant PDUs. The minimum number of duplicate pairs of letters in all disk systems indicates the products are protected against cascading faults.

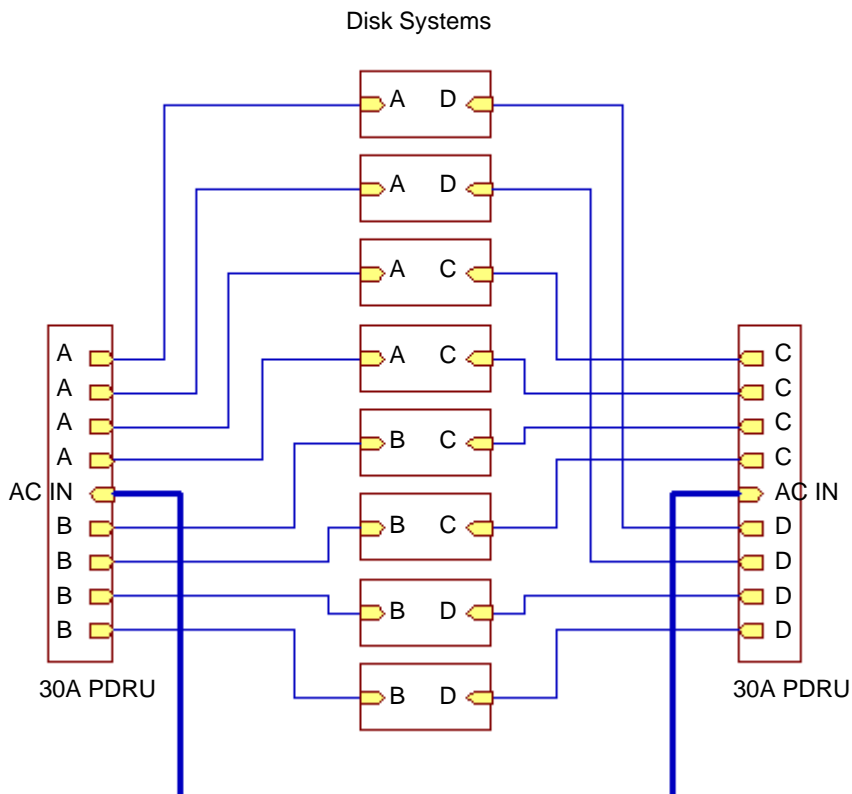

Figure 27 Wiring Scheme for 1.6 Meter Rack

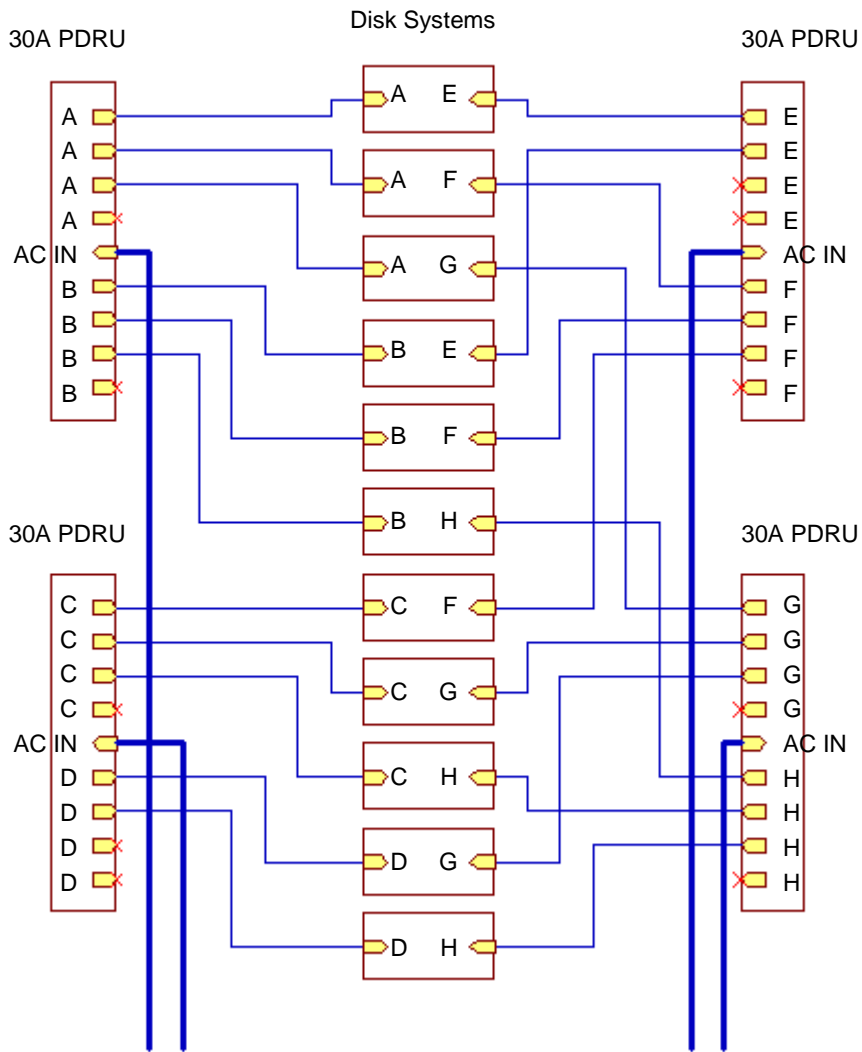

Figure 28 Wiring Scheme for 2.0 Meter Rack

Step 8: Install Disks and Fillers

Caution Touching exposed areas on the disk can cause electrical discharge and disable the disk. Be sure you are grounded and be careful not to touch exposed circuits.



Disks are fragile and ESD sensitive. Dropping one end of the disk just two inches is enough to cause permanent damage. In addition, static electricity can destroy the magnetic properties of recording surfaces. Grip disks only by their handles (A in Figure 29) and carriers (D), and follow strict ESD procedures.

1. Open the disk system door.
2. Put on the ESD strap provided and insert the metal end into the ESD socket (D in Figure 29) on the front of the disk system.

Caution Disks are fragile. Handle carefully and do NOT touch the exposed circuit board.

3. Remove the bagged disk from the disk pack and, grasping the disk by its handle (A), remove the ESD bag.
4. Open the cam latch (B) by pulling the tab toward you.
5. Insert the disk into an empty slot, aligning the disk insertion guides (E) with the slot guides (F) in the top and bottom of the disk system.

Note You can install disks in any slots. Working in left to right order optimizes hand access.

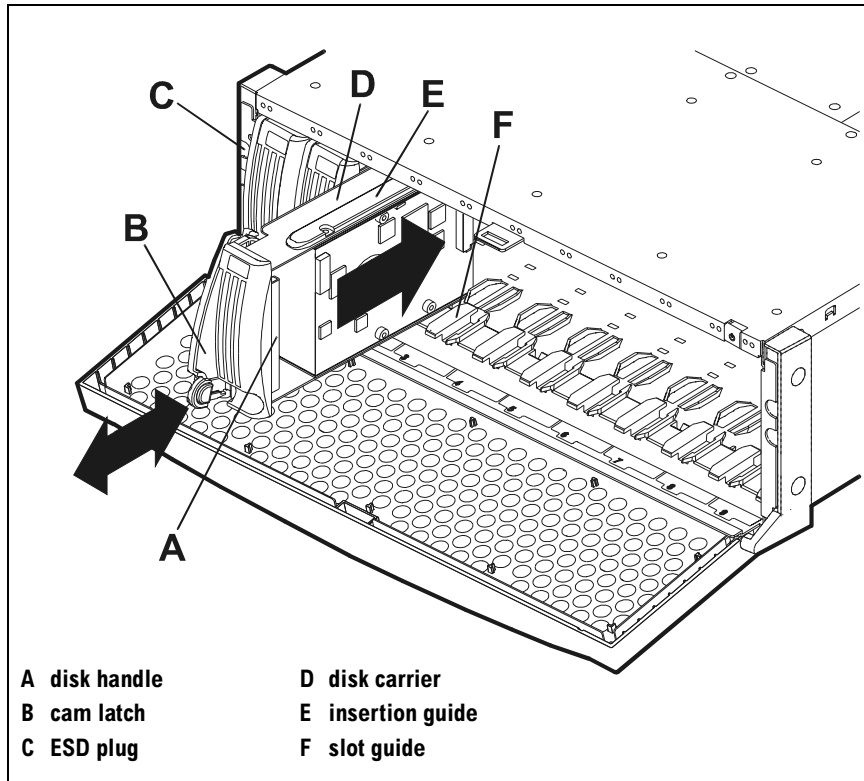

Figure 29 Disk Insertion

6. Seat the disk firmly on the backplane by pushing the cam latch toward the disk until it clicks.
7. Repeat steps 3–6 to install additional disks. At least four of the ten slots must contain disks.

Caution Every slot must contain either a disk or filler.

8. Insert disk fillers in remaining empty slots. (See Figure 30.)

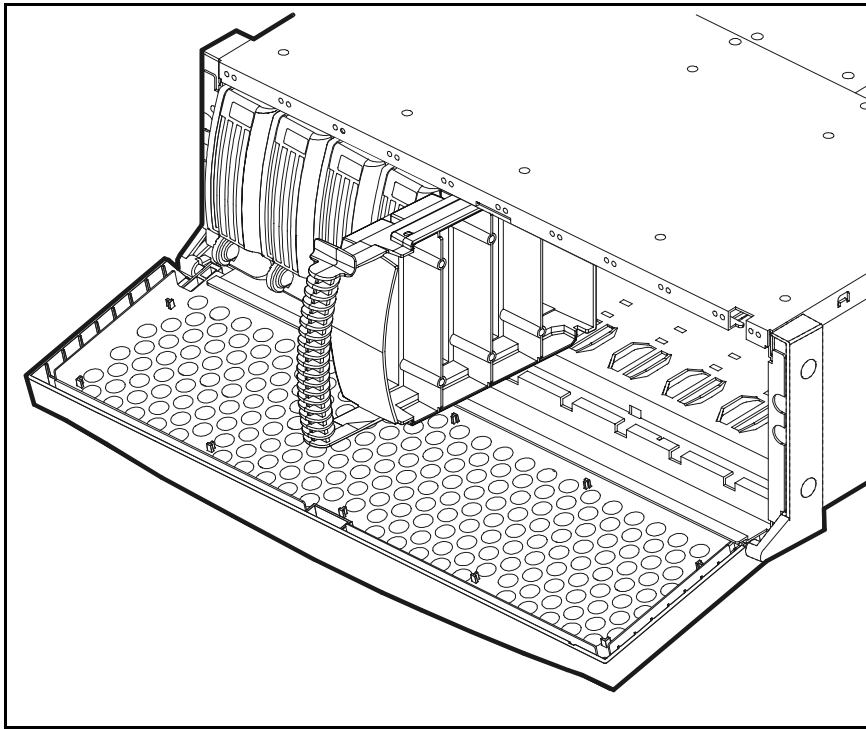

Figure 30 Disk Filler Insertion

Step 9: Turn on the Disk System

Caution When starting up the disk system, do not override automatic spin-up by issuing SCSI start commands to the drives. Doing so could cause an overcurrent fault mode, requiring a power cycle to recover.

1. Press the power button (A in Figure 31) to turn on the disk system.
2. Watch the system LEDs for confirmation that the product is operational. The power LED (B) should be green, and the fault LED (C) should be off.

If the LEDs indicate a problem, refer to chapter 4, Troubleshooting.

Note An amber light that is on briefly when a component turns on is normal. If this light remains on more than a couple seconds, a fault has been detected.

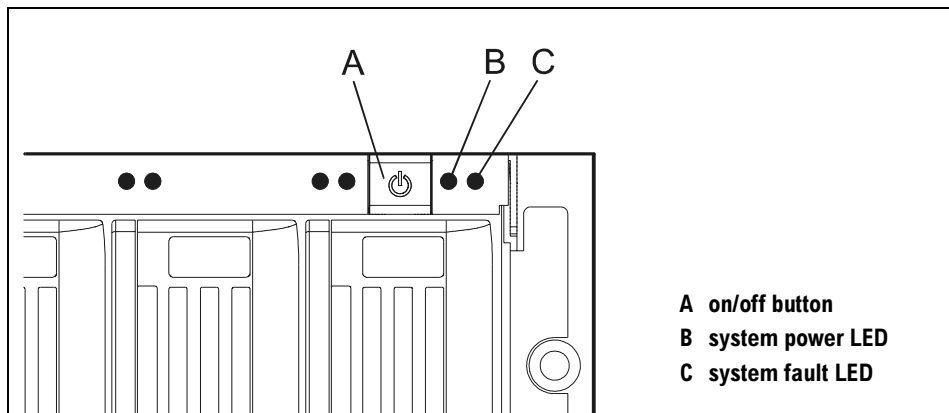

Figure 31 On/Off Button and System LEDs

3. Close and lock the disk system door.

3

CONFIGURATION

Viewing a Disk System in IOSCAN

Setting Up the Hardware Event Monitor

Annotating Devices

Updating Firmware (HP-Qualified Only)

Viewing a Disk System in IOSCAN

The disk system is visible to HP systems running HP-UX 10.20 TFC or 11.0. An IOSCAN (example below) shows each LCC and disk in the system; in fact, it shows the same devices on both loops when both LCCs are connected to the host.

Sample IOSCAN

Type the command: **ioscan -fn**

```
Class      I   H/W Path          Driver      S/W State  H/W Type   Description
-----
fcplib     0   8/12.8            fcplib     CLAIMED    INTERFACE  FCP Protocol Adapt
ext_bus    5   8/12.8.0.255.0    fcpdev     CLAIMED    INTERFACE  FCP Device Interfa
target     7   8/12.8.0.255.0.0  tgt        CLAIMED    DEVICE      SEAGATE ST39102FC
disk      16  8/12.8.0.255.0.0.0
sdisk     CLAIMED    DEVICE
/dev/dsk/c5t0d0 /dev/rdisk/c5t0d0
target     8   8/12.8.0.255.0.1  tgt        CLAIMED    DEVICE      SEAGATE ST39102FC
disk      4   8/12.8.0.255.0.1.0
sdisk     CLAIMED    DEVICE
/dev/dsk/c5t1d0 /dev/rdisk/c5t1d0
target     15  8/12.8.0.255.0.2  tgt        CLAIMED    DEVICE      SEAGATE ST39102FC
disk      3   8/12.8.0.255.0.2.0
sdisk     CLAIMED    DEVICE
/dev/dsk/c5t2d0 /dev/rdisk/c5t2d0
target     14  8/12.8.0.255.0.3  tgt        CLAIMED    DEVICE      SEAGATE ST39102FC
disk      5   8/12.8.0.255.0.3.0
sdisk     CLAIMED    DEVICE
/dev/dsk/c5t3d0 /dev/rdisk/c5t3d0
.
.
.
target     17  8/12.8.0.255.0.8  tgt        CLAIMED    DEVICE
disk      6   8/12.8.0.255.0.8.0
sdisk     CLAIMED    DEVICE
/dev/dsk/c5t8d0 /dev/rdisk/c5t8d0
target     12  8/12.8.0.255.0.9  tgt        CLAIMED    DEVICE      SEAGATE ST39102FC
disk      7   8/12.8.0.255.0.9.0
sdisk     CLAIMED    DEVICE
/dev/dsk/c5t9d0 /dev/rdisk/c5t9d0
target     13  8/12.8.0.255.0.10 tgt        CLAIMED    DEVICE      HP A5236A
disk      5   8/12.8.0.255.0.10.0
ctl       CLAIMED    DEVICE
/dev/rscsi/c5t10d0
.
.
.
fcplib     1   10/12.8           fcplib     CLAIMED    INTERFACE  FCP Protocol Adapter
ext_bus    7   10/12.8.0.255.0    fcpdev     CLAIMED    INTERFACE  FCP Device interface
target     16  10/12.8.0.255.0.0  tgt        CLAIMED    DEVICE      SEAGATE ST39102FC
disk      42  10/12.8.0.255.0.0.0
sdisk     CLAIMED    DEVICE
/dev/dsk/c7t0d0 /dev/rdisk/c7t0d0
target     17  10/12.8.0.255.0.1  tgt        CLAIMED    DEVICE
```

```

disk      43    10/12.8.0.255.0.1.0    sdisk      CLAIMED   DEVICE      SEAGATE ST39102FC
           /dev/dsk/c7t1d0      /dev/rdisk/c7t1d0
target    18    10/12.8.0.255.0.2      tgt        CLAIMED   DEVICE
disk      40    10/12.8.0.255.0.2.0    sdisk      CLAIMED   DEVICE      SEAGATE ST39102FC
           /dev/dsk/c7t2d0      /dev/rdisk/c7t2d0
target    19    10/12.8.0.255.0.3      tgt        CLAIMED   DEVICE
disk      41    10/12.8.0.255.0.3.0    sdisk      CLAIMED   DEVICE      SEAGATE ST39102FC
           /dev/dsk/c7t3d0      /dev/rdisk/c7t3d0
.
.
.
target    24    10/12.8.0.255.0.8      tgt        CLAIMED   DEVICE
disk      28    10/12.8.0.255.0.8.0    sdisk      CLAIMED   DEVICE      SEAGATE ST39102FC
           /dev/dsk/c7t8d0      /dev/rdisk/c7t8d0
target    25    10/12.8.0.255.0.9      tgt        CLAIMED   DEVICE
disk      29    10/12.8.0.255.0.9.0    sdisk      CLAIMED   DEVICE      SEAGATE ST39102FC
           /dev/dsk/c7t9d0      /dev/rdisk/c7t9d0
target    26    10/12.8.0.255.0.10     tgt        CLAIMED   DEVICE
ctl       8      10/12.8.0.255.0.10.0   sctl1     CLAIMED   DEVICE      HP A5236A
           /dev/rscsi/c7t10d0

```

This example shows redundant loops to the same disk system and disks, one on the bus/adaptor path 8/12.8 and the other on 10/12.8. The eleventh target in each group, at 8/12.8.0.255.0.10 and 10/12.8.0.255.0.10, is the LCC on that loop. The Enclosure ID on this unit is 0. See Table 11 and 12 for the corresponding bus and target IDs with other Enclosure IDs.

The disks (ST39102FC) shown in this example are 9 Gbyte Half Height. Other valid disks are:

- ST39103FC 9 Gbyte Low Profile
- ST118202FC 18 Gbyte Half Height
- ST318203FC 18 Gbyte Low Profile
- ST136403FC 36 Gbyte Half Height

Interpreting the Hardware Path

The elements of the Fibre Channel hardware path are interpreted as follows:

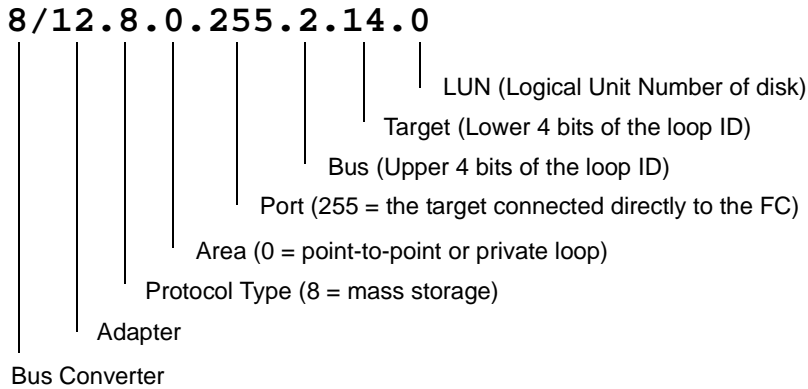

The loop ID, broken out in upper and lower bits in the example above, is 46. To derive the loop ID from the Bus and Target values of the hardware path:

- Convert the Bus and Target fields (the upper and lower bits of the loop ID) to binary:

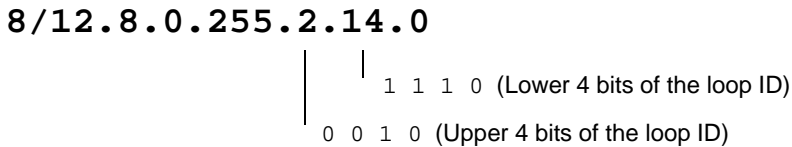

- Combine the two binary fields into 8 bits and convert back to decimal:

Upper bit	Lower bit	
0 0 1 0	1 1 1 0	
32	+ 8+4+2	= 46

Loop IDs and Hardware Paths by Enclosure ID

Enclosure IDs (0 through 9) are set with a dial on the LCC. This setting determines the FC-AL IDs of the disks and LCCs in the disk system. See Table 11 and Table 12 for the FC-AL IDs and corresponding hardware paths for each slot and LCC based on the Enclosure ID.

Table 11 Loop IDs and Hardware Paths by Slot Number and Enclosure ID 0–4

Encl. ID	0			1			2			3			4			
	Slot #	Loop ID	HW Path		Loop ID	HW Path		Loop ID	HW Path		Loop ID	HW Path		Loop ID	HW Path	
			Bus	Target		Bus	Target		Bus	Target		Bus	Target		Bus	Target
0	0	0	0	12	0	12	24	1	8	36	2	4	48	3	0	
1	1	0	1	13	0	13	25	1	9	37	2	5	49	3	1	
2	2	0	2	14	0	14	26	1	10	38	2	6	50	3	2	
3	3	0	3	15	0	15	27	1	11	39	2	7	51	3	3	
4	4	0	4	16	1	0	28	1	12	40	2	8	52	3	4	
5	5	0	5	17	1	1	29	1	13	41	2	9	53	3	5	
6	6	0	6	18	1	2	30	1	14	42	2	10	54	3	6	
7	7	0	7	19	1	3	31	1	15	43	2	11	55	3	7	
8	8	0	8	20	1	4	32	2	0	44	2	12	56	3	8	
9	9	0	9	21	1	5	33	2	1	45	2	13	57	3	9	
LCC	10	0	10	22	1	6	34	2	2	46	2	14	58	3	10	
RSVD	11	0	11	23	1	7	35	2	3	47	2	15	59	3	11	

Table 12 Loop IDs and Hardware Paths by Slot Number and Enclosure ID 5–9

Encl. ID	5			6			7			8			9		
Slot #	Loop ID	HW Path		Loop ID	HW Path		Loop ID	HW Path		Loop ID	HW Path		Loop ID	HW Path	
		Bus	Target		Bus	Target		Bus	Target		Bus	Target		Bus	Target
0	60	3	12	72	4	8	84	5	4	96	6	0	108	6	12
1	61	3	13	73	4	9	85	5	5	97	6	1	109	6	13
2	62	3	14	74	4	10	86	5	6	98	6	2	110	6	14
3	63	3	15	75	4	11	87	5	7	99	6	3	111	6	15
4	64	4	0	76	4	12	88	5	8	100	6	4	112	7	0
5	65	4	1	77	4	13	89	5	9	101	6	5	113	7	1
6	66	4	2	78	4	14	90	5	10	102	6	6	114	7	2
7	67	4	3	79	4	15	91	5	11	103	6	7	115	7	3
8	68	4	4	80	5	0	92	5	12	104	6	8	116	7	4
9	69	4	5	81	5	1	93	5	13	105	6	9	117	7	5
LCC	70	4	6	82	5	2	94	5	14	106	6	10	118	7	6
RSVD	71	4	7	83	5	3	95	5	15	107	6	11	119	7	7

Caution The Enclosure IDs on both LCCs in the same disk system must be identical.

For redundancy, each LCC is connected to a different Fibre Channel loop (that is, a different host bus adapter).

Setting Up the Hardware Event Monitor

Separate monitors watch over the disks and the disk system. You need to install and configure the Disk Monitor (disk_em) and the High Availability Storage System Monitor (dm_ses_enclosure) for complete event notification.

To install and configure the required monitors, refer to the *EMS Hardware Monitors User's Guide*, which is included in Adobe Acrobat format on the IPR Support Media. You can download a copy of Acrobat Reader without charge from <http://www.adobe.com/prodindex/acrobat/readstep.html>.

Annotating Devices

Using host-based software, you can “label” each disk system with any information that would be useful for the site. You might use this feature to assign an inventory number or to indicate the location of the product. The maximum length of the annotation is 256 characters.

Using SAM

To define a text string using SAM, select the desired LCC or disk from the Disk Devices list; then select **Annotate Device** from the Actions menu. SAM displays the following window:



Figure 32 Annotate Device Using SAM

Type the comment that you want in the Annotation field and select **OK**.

You can view the annotation through the Annotate Device option in the Actions menu or by displaying the Annotation column in the Disk Devices list. To include the Annotation column in the Disk Devices window, select **Columns** from the View menu and choose **Annotation**.

Using STM (HP-Qualified Only)

Annotating devices is a password-protected function of STM (Support Tools Manager). Use the System menu License option to install the HP-Only license before you select the annotate function.

1. Run STM and install the HP-Only license.
2. Select the desired LCC.
3. Select **Expert Tool > Run** from the Tools menu. An Expert Tool window opens.
4. Select **Write Label** from the Info menu. The user Defined Annotation window displays the existing label in an edit field.

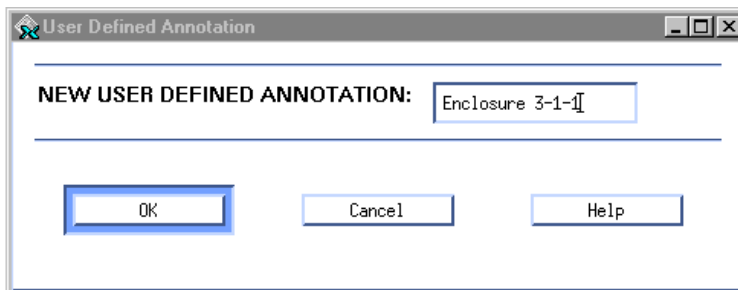

Figure 33 Annotate Device Using STM

5. Type the desired text in the New User Defined Annotation field. Click **OK**. The new label will replace the existing label.

To view the annotation of a selected disk system, select **Read Label** from the Expert Tool Info menu. The label is displayed in the Expert Tool window.

Updating Firmware (HP-Qualified Only)

Obtain the latest disk system firmware release from the support web site before traveling to the customer site. When you arrive at the site:

1. Save the firmware file on the customer's system, preferably in the default firmware directory: `/var/tmp`
2. If you want to run STM in graphic mode, make sure `DISPLAY` is exported.
3. Start STM by typing `xstm&` on the HP-UX command line. This command starts the graphic version of STM and keeps the X window open when you quit STM.
4. Select **License** from the System menu and install the password-protected HP-Only license.
5. Select **Firmware Update > Run** from the Tools menu. A tool window opens, displaying the current firmware version and instructions for updating. A second window lists the available firmware files in the `var/tmp` directory.

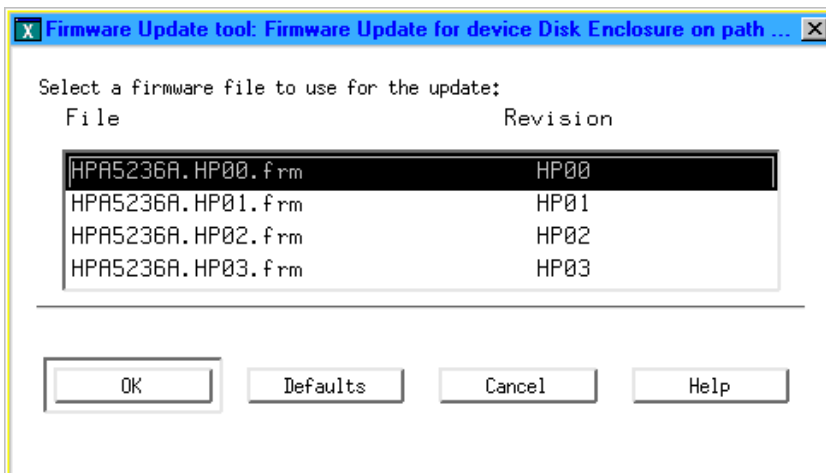

Figure 34 Firmware File Selection Window

If there are no firmware files in the default directory, a pop-up window instructs you to select an optional path and STM displays a list of directories. Enter the directory path you used to save the firmware file (in step 1) and click **OK**.

6. Select the firmware file from the list of files displayed in the default or specified directory. Click **OK**.
7. Select **Start Update...** from the Update menu. STM prompts you to confirm or cancel the firmware update.

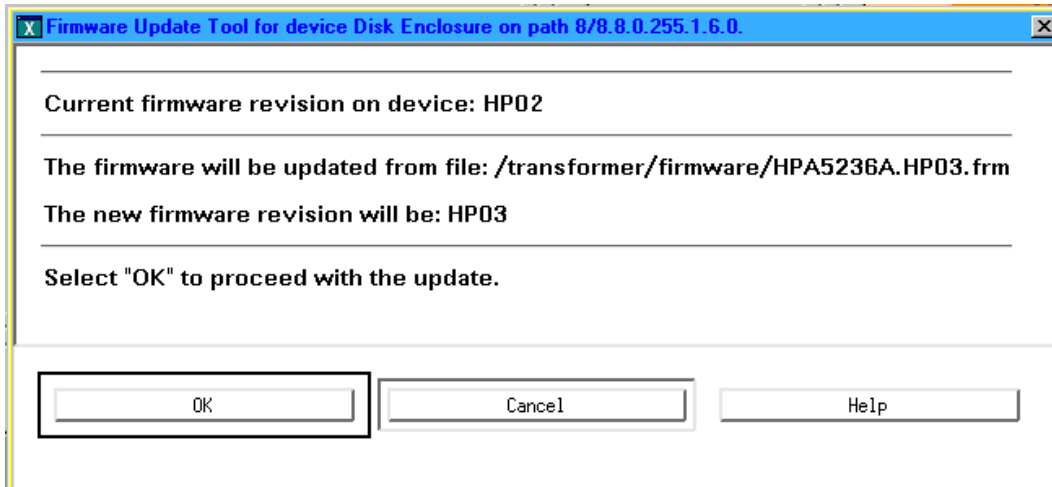

Figure 35 Firmware Download Confirmation Window

The results of your action appear in the Tool window.

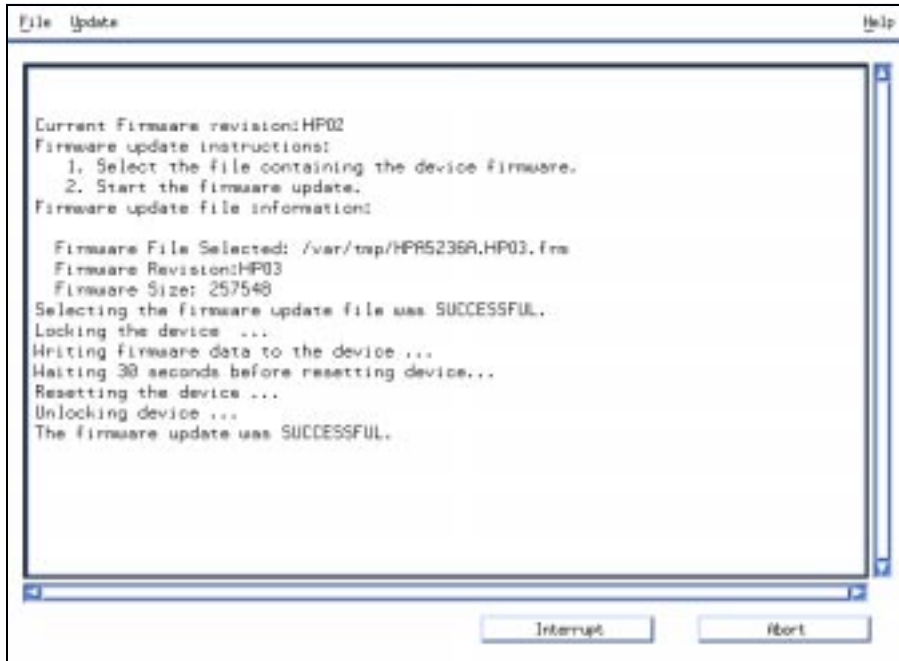

Figure 36 Firmware Tool Window

Overview

Event Notification

Status LEDs

Online Status Information

Checking the Fibre Channel Link

Isolating Causes

Overview

The following procedure will help you identify and resolve disk system failures:

1. Gather information from all sources:
 - Hardware Event notifications
 - Disk system LED status indicators
 - Online status information and error logs (SAM/STM)
2. Check the Fibre Channel link.
3. Isolate the cause of the problem.
4. Correct the problem. (See chapter 5 for removal and replacement instructions.)
5. Verify operational status with IOSCAN or other host utilities.

Event Notification

The EMS hardware event monitor polls enclosure services on the LCC and reports any changes in the status of monitored components. Depending on how the monitor is set up, you can receive messages at the console, in email, in a log file, or through third-party applications. These messages are likely to be the first indication of a problem with a disk system.

Events are reported for all disk system replaceable components—LCCs, disks, power supplies, fans, and GBICs—as well as for temperature, voltage, and communications.

Messages identify five levels of severity:

- | | |
|----------------------|---|
| Critical | An event that causes data loss, host system downtime, or other loss of service. Host system operation will be affected if the disk system continues to be used without correction of the problem. Immediate action is required. |
| Serious | An event that may cause data loss, host system downtime, or other loss of service if left uncorrected. Host system and hardware operation may be adversely affected. The problem needs repair as soon as possible. |
| Major Warning | An event that could escalate to a serious condition if not corrected. Host system operation should not be affected and normal use of the disk system can continue. Repair is needed but at a convenient time. |
| Minor Warning | An event that will not likely escalate to a severe condition if left uncorrected. Host system operation will not be interrupted and normal use of the disk system can continue. The problem can be repaired at a convenient time. |

Information An event that is expected as part of the normal operation of the hardware. No action is required.

Event messages (shown in Figure 37) contain the following:

- **Message Data** – Date and time the message was sent, the source and destination of the message, and the severity level
- **Event Data** – Date and time of the event, the host, event ID, name of the monitor, event number, event class, severity level, hardware path, associated OS error log entry ID
- **Error Description** – Narrative information indicating the component that experienced the event and the nature of the event
- **Probable Cause/Recommended Action** – The cause of the event and suggested steps toward a solution. This information should be the first step in troubleshooting.
- **Annotation** – The user-defined annotation associated with the disk system.

```
Notification Time: Thu Aug 6 15:18:03 1998
yourserver sent Event Monitor notification information:
/peripherals/events/mass_storage/fibre-channel/enclosure/
10_12.8.0.255.0.10.0 is !=1.
Its current value is CRITICAL(5)

Event data from monitor:

Event Time: Thu Aug 6 15:18:03 1998
Hostname: yourserver.rose.hp.com      IP Address: 15.43.212.175
Event ID: 0x0035ca2b9b00000002      Monitor: dm_ses_enclosure
Event # : 101                        Event Class: I/O
Severity: Critical

Enclosure at hardware path 10/12.8.0.255.0.10.0: Hardware failure
Associated OS error log entry id(s): None

Description of Error:

    The disk device is indicating a fault.

Probable Cause/Recommended Action:

    The disk drive in slot 1 has failed. Check the connection, reseal,
    or replace the disk drive.
```

Figure 37 Sample Hardware Event Notification

Status LEDs

Each replaceable component has an LED that shows the results of power-on self-tests and indicates the functional status of the device within the component. Two system LEDs, green and amber, are visible with the door closed on the front of the disk system. The failure of any replaceable component—disk, power supply, fan, LCC, or GBIC—activates not only the component's fault LED, but also the system fault LED.

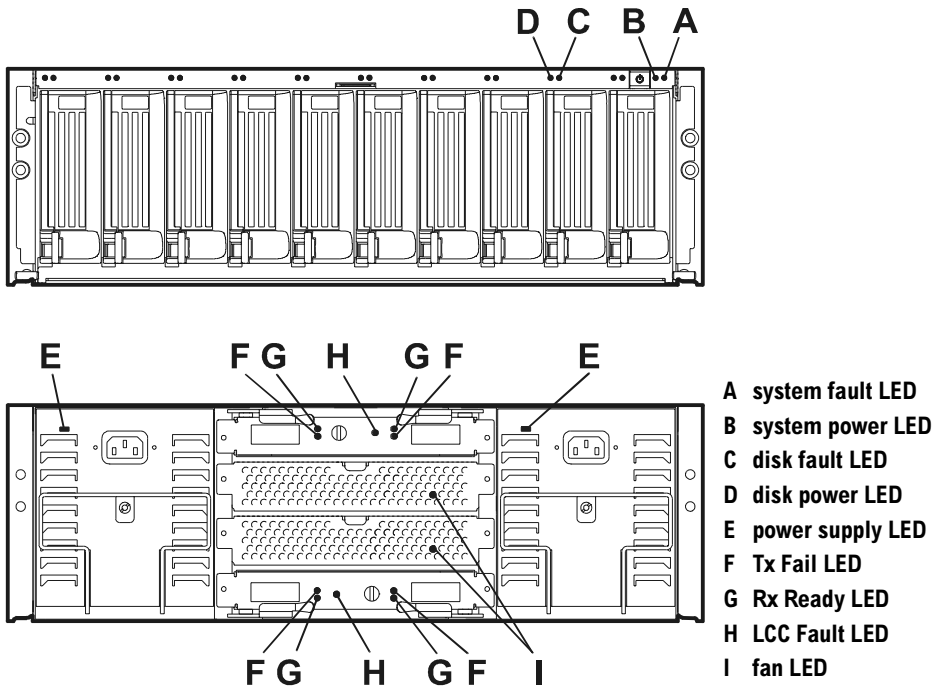

Figure 38 LED Status Indicators

Interpret LED states as shown in Table 13:

Table 13 LED Functions

LED	State	Indication
System Power	Green	Power is on
	OFF	Power is off
System Fault	Amber	Self-test ¹ / Problem ²
	OFF	Normal operation
LCC Fault	Amber	Self-test ¹ / LCC Fault or mismatched Enclosure IDs
	OFF	Normal operation
GBIC Rx Ready	Green	Connected
	OFF	Not connected
GBIC Tx Fail	Amber	Cannot transmit
	OFF	Normal operation
Fan	Amber	Startup ¹ / Fault
	Green	Normal operation
	OFF	Not installed

- 1 Startup and self-tests occur briefly when the unit is powered on.
- 2 A component has failed; temperature or voltage is out of normal range. See Isolating Causes on page 99
- 3 When a disk is installed with the power on, its activity LED passes through the sequence: steady on, slow blink, fast blink, and, again, steady on. The duration of each state depends on various factors, including the quantity and location of the disks being installed. The complete sequence lasts from 20 to 60 seconds for one disk and up to 1.5 minutes for all ten disks.

Table 13 LED Functions (cont'd)

LED	State	Indication
Power Supply	Amber	Startup ¹ / Fault
	Green	Operating
	OFF	Not installed
Disk Fault	Amber	Self-test ¹ / Fault
	Slow blink	SAM/STM initiated
	OFF	Normal operation
Disk Activity ³	Initial green	Installed
	Slow blink	Waiting
	Fast blink	Spinning up
	Steady green	Normal operation
	Very fast blink	Data input/output
	OFF	Not installed

1 Startup and self-tests occur briefly when the unit is powered on.
2 A component has failed; temperature or voltage is out of normal range. See Isolating Causes on page 99
3 When a disk is installed with the power on, its activity LED passes through the sequence: steady on, slow blink, fast blink, and, again, steady on. The duration of each state depends on various factors, including the quantity and location of the disks being installed. The complete sequence lasts from 20 to 60 seconds for one disk and up to 1.5 minutes for all ten disks.

Note An amber light that is on briefly when a component first comes on is normal. If this light remains on more than a couple of seconds, a fault has been detected.

Online Status Information

Software applications that run on the HP-UX host display status and descriptive information about the disk system and its components. SAM is the system administrator's interface to specific HP-UX functions. STM is the service engineer's tool for information, diagnostics, firmware updates, and more.

Viewing Component Status in SAM

SAM displays the status of disk system components on the host console. Follow the instructions below to use SAM:

1. Select **Disks and File Systems** from the main window.
2. Select **Disk Devices**. SAM displays the hardware paths of all disks, disk systems, and arrays on the host.
3. Select the path that represents the LCC of the desired disk system. You can recognize the LCC by the description "HP FC HA Storage System 1010D Controller."
4. Select **View More Info** from the Actions menu. A window displays header information and a graphical representation of the front of the disk system. See Figure 39.

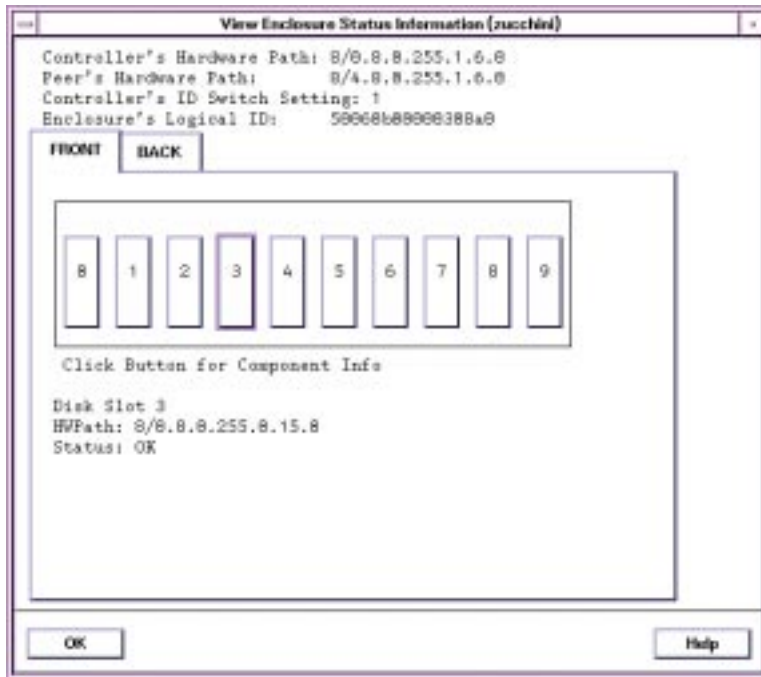

Figure 39 Sample Disk System Information Displayed by SAM – Front View

The header provides the following information:

- LCC Hardware path – the path chosen from the Disk Devices list
- Peer LCC Hardware path – the path to the other LCC in the same unit
- Controller's ID Switch Setting – Enclosure ID, set by the dial on the LCC bulkhead
- Enclosure's logical ID – the enclosure's World Wide Name, a unique identifier in the Fibre Channel network

5. For a view of the back of the selected disk system, click the "Back" tab. See Figure 40.

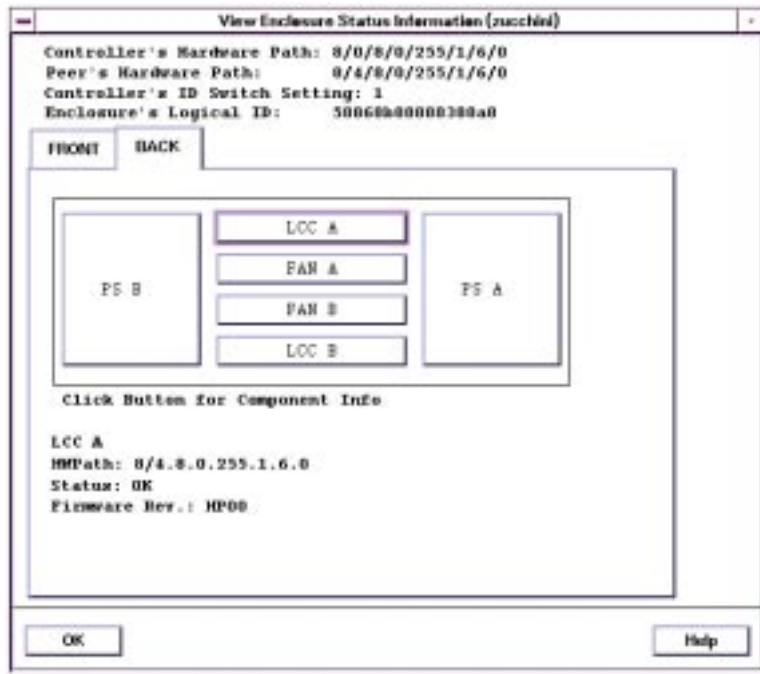

Figure 40 Sample Disk System Information Displayed by SAM – Rear View

- To view component information, click the button representing the component. (The disk in slot 3 is selected in Figure 39. LCC A is selected in Figure 40.) SAM displays the following information about specific components:

Button	Displays
Disk	Disk slot, hardware path, status
LCC	Hardware path, status, firmware revision
Fan	Name, status
Power supply	Name, status

Status values are OK, critical error, firmware mismatch on controllers, not installed, and status not available. See Interpreting Status Values on page 96 for the meanings of these terms.

Viewing the STM Information Log

STM (Support Tools Manager) generates Information and Activity logs for a selected disk system. Execute STM in an X window and run the Information tool as follows.

1. At the system prompt, type **xstm&**
2. Select the desired FC Disk Enclosure (HPA5236A).
3. Select **Information** from the Tools menu.
4. To generate a current log, select **Run**.
5. To view log output, select **Information** from the Tools menu.
6. Select **Information Log**.
7. Select **Done** when you are finished with the information.

The contents of the STM Information Log are as follows:

Log creation time	The date and time the Information Tool was last run for the selected disk system
Hardware path	The physical path from the host to the reporting LCC; for example, 8/12.8.0.255.2.14.0
Product ID	A5236A, the HP product number of the disk system
FC Loop ID	The FC-AL ID of the reporting LCC, a decimal value between 0 and 125
LCC A Status	The reported status of the upper LCC in the selected disk system. Possible values are OK, critical, noncritical, not installed, or not available.

LCC B Status	The reported status of the lower LCC in the selected disk system. Possible values are OK, critical, noncritical, not installed, or not available.
Reporting LCC	LCC A or LCC B, whichever LCC corresponds to the selected hardware path
Enclosure ID	The numerical setting, 0 - 9, of the Enclosure ID dial on the reporting LCC
LCC Serial No.	The unique manufacturer number that distinguishes the reporting LCC from all other LCCs
WW Name (node)	The World Wide Name assigned to this disk system. In normal operation, this value is the same as the World Wide Name (port) for LCC A, the card in the top slot.
WW Name (port)	The World Wide Name of the reporting LCC
Firmware Rev.	The current firmware version on the reporting LCC
Fan Status	The status of the upper (Module A) and lower (Module B) fans in the selected disk system. Possible values are OK, critical, not installed, or not available.
Power Supply Status	The status of the left (Supply A) and right (Supply B) power supplies in the selected disk system. Possible values are OK, critical, not installed, or not available.
Voltage Sensors Voltage	The voltage detected by three voltage sensors—3.3V, 5.0V, and 12V—on LCC A and LCC B. Possible values range from -327.67V to 327.67V.
Voltage Sensors Status	The status of three voltage sensors—3.3V, 5.0V, and 12V—on LCC A and LCC B. Possible values are OK, critical, noncritical, not installed, unknown, or not available.

**Temp Sensors
Temperature**

The temperature, in degrees Celsius, detected by four sensors. Possible values range from -19 to 245 degrees.

**Temp Sensors
Status**

The status of four temperature sensors. Possible values are OK, critical, noncritical, not installed, unknown, or not available.

Interpreting Status Values

SAM and STM report status in common terms, which are defined as follows:

Table 14 Status Indications

Reported Status	Applicable Component	Indication
OK	All replaceable components and sensors	Component is installed and no error conditions are known.
Critical	Replaceable components	Hardware has failed.
	Sensors	Voltage/temperature exceeds critical limit.
Noncritical	LCC	LCC A and LCC B have different firmware versions.
	Sensors	Voltage/temperature exceeds warning limit.
Not Installed	All replaceable components and sensors	Component is not installed.
Unknown	Sensors	Sensor has failed or status is not available.
Not Available	All replaceable components and sensors	Component is installed without known errors, but has not been turned on or set into operation.

Checking the Fibre Channel Link

At power up, the disk system and the host Fibre Channel I/O adapters default to Fibre Channel Arbitrated Loop (FC-AL). Use HP-UX FCMSUTIL on the host to verify that the loop is operating correctly. Then check the Fibre Channel cables and connectors.

1. Run FCMSUTIL as follows.

FCMSUTIL uses the device files of the Fibre Channel I/O adapters. If the device files do not exist, they must be created. To create the device files, first run the IOSCAN command against the Fibre Channel driver to find the minor numbers. For example:

```
ioscan -fnd fcTl_cntl
```

Output similar to the following will appear:

```
Class I  H/W Path  Driver      S/W State  H/W Type  Description
=====
lan    0   8/8.5     fcTl_cntl  CLAIMED    INTERFACE HP Fibre Channel Mass Stora
                        /dev/fcms0
lan    1   8/12.5    fcTl_cntl  CLAIMED    INTERFACEHP Fibre Channel Mass Stora
                        /dev/fcms1
```

Next, run the LSDEV command to find the major number of the Fibre Channel driver:

```
lsdev | grep fcTl_cntl
```

Output similar to the following will display. The major number is the first item in the output line.

```
78    -1    fcTl_cntl  lan
```

Next, run the MKNOD command to create the device files using the major and minor numbers from the LSDEV and IOSCAN output. The minor numbers are under the “I” column.

```
mknod /dev/fcms1 c 78 0x000000
mknod /dev/fcms1 c 78 0x010000
```

After the device files have been created, issue the FCMSUTIL command on the device files. For example:

```
/opt/fcms/bin/fcmsutil /dev/fcms0
```

The output should appear similar to the following:

```
Local N_Port_ID is = 0x000001
N_Port Node World Wide Name = 0x10000060B03E22CB
N_Port World Wide Name = 0x10000060B03E22CB
Topology = IN_LOOP
Speed = 1062500000 (bps)
HPA of card = 0xFBFB48000
EIM of card = 0xFFFFA000A
Driver state = Ready
Number of EDB's in use = 0
Number of OIB's in use = 0
Number of Active Outbound Exchanges = 1
Number of Active Login Sessions = 5
```

A driver state of Ready indicates that the driver is in the correct operating state. IN_LOOP topology indicates that the host has detected an FC-AL.

2. Check Fibre Channel cables for loose connections.
3. Check the Enclosure ID switches for conflicting loop IDs. Make sure both LCCs have the same ID setting.

Isolating Causes

Table 15 lists the probable causes and solutions for problems you may detect on the disk system. When more than one problem applies to your situation, investigate the first description that applies. The table lists the most basic problems first and excludes them from subsequent problem descriptions.

Table 15 Troubleshooting Table

Problem Description	HWEvent Category	LED State	Status		Probable Cause/Solution
			SAM	STM	
Installed disk system does not power on	none	System power LED off	none	none	<ul style="list-style-type: none"> – Neither power cord is plugged in. – The power switch is not pressed. – AC breaker is tripped. – AC power source has failed. – The PDU/PDRU is defective. – Power switch is defective. – A faulty component is causing power supplies to turn off. Remove all components and reinsert one at a time until the faulty component is isolated.
Installed disk system beeps when powered on	none	System fault & both LCC Fault LEDs on	none	none	Enclosure IDs on peer LCCs do not match. Determine the correct Enclosure ID and reset the ID on one or both LCCs. Reinsert the LCC(s) with the changed ID.
System fault LED is on	none	Power supply LED off	Power supply Not Available	Power supply Not Available	<ul style="list-style-type: none"> – The power supply is not plugged in. – The PDU/PDRU or primary power source has failed.
	Critical	Part fault LED on	Critical	Critical	A component has failed. See problem descriptions below.

Table 15 Troubleshooting Table (cont'd)

Problem Description	HWEvent Category	LED State	Status		Probable Cause/Solution
			SAM	STM	
Disk fault LED is on	Critical	Fault LED on	Critical	(See STM Disk Tool)	Disk hardware is faulty. Replace the disk.
Power supply LED is amber	Critical	Amber	Critical	Critical	<ul style="list-style-type: none"> – An incompatible or defective component caused a temporary fault. – Power supply hardware is faulty. Unplug the power cord and wait for the LED to turn off. Reinsert the power cord. If fault persists, replace the power supply.
Fan LED is amber	Critical	Amber	Critical	Critical	Fan has slowed or stopped. Replace the fan.
LCC fault LED is on	Critical	LCC Fault LED on	Critical	Critical	LCC hardware is faulty. Replace the LCC.
LCC fault LED is on and the disk system beeps	none	LCC Fault on	none	none	The Enclosure ID on the installed LCC does not match the Enclosure ID on the peer LCC. Reset the Enclosure ID and reinsert the LCC.
GBIC fault LED is on	Critical	Tx Fail LED on	none	none	<ul style="list-style-type: none"> – GBIC transmission circuit has failed. – GBIC is not receiving power. Reseat the GBIC. If problem persists, replace GBIC. If the replacement GBIC fails, contact HP technical support.

Table 15 Troubleshooting Table (cont'd)

Problem Description	HWEvent Category	LED State	Status		Probable Cause/Solution
			SAM	STM	
IOSCAN lists disks and LCC controller as NO_HW	Critical	Rx Rdy off	none	none	<ul style="list-style-type: none"> – Fibre Channel cable is unplugged or loose at either end. – Fibre Channel cable is damaged. Replace with another cable to test. – Prior units in the daisy chain are powered off. Reroute Fibre Channel cables around disabled units. – Loop is dead. See Checking the Fibre Channel Link on page 97 to verify driver operation. – GBIC and/or LCC is faulty. Check status and correct any problem.
		all normal	none	none	<ul style="list-style-type: none"> – Internal loop is dead, and LCC is bypassed. – External loop is dead. See Checking the Fibre Channel Link on page 97.
IOSCAN lists a disk device as NO_HW	none	Power LED on; Fault LED off	Not Available	(See STM Disk Tool)	<ul style="list-style-type: none"> – Node is bypassed by hardware action. Reseat the component and, if problem persists, replace. – Node is bypassed by software command.

Table 15 Troubleshooting Table (cont'd)

Problem Description	HWEvent Category	LED State	Status		Probable Cause/Solution
			SAM	STM	
Temperature is over limit	Critical	none	none	Critical Temp is >54.5° C	<ul style="list-style-type: none"> – A fan is faulty. Check status and correct. – Airflow is obstructed; vents are blocked. – One or more slots are empty. – Power supply is faulty. Check status and correct. – Room temperature is too high. If ambient temperature cannot be reduced in a reasonable time, turn off product to prevent shortened life. – Temperature sensor is faulty. Compare temperature reported by peer LCC.
	Major Warning	none	none	Non-critical Temp is >36° C	
<p>Temperature sensors are on the LCC and are independent of power supplies. Investigate temperature warnings immediately, before power supplies sense critical temperature and turn off.</p>					
Temperature is under limit	Critical	none	none	Critical Temps <9.5° C	<ul style="list-style-type: none"> – Room temperature is too low. – Temperature sensor is faulty. Compare temperature reported by peer LCC.
	Major Warning	none	none	Non-critical Temps <15.5° C	
Voltage is over limit	Critical	none	none	Critical	Power supply is faulty. Check status and correct.
	Major Warning	none	none	Non-critical	
Voltage is under limit	Critical	none	none	Critical	Either power supply is faulty. Check status and correct.
	Major Warning	none	none	Non-critical	

Table 15 Troubleshooting Table (cont'd)

Problem Description	HWEvent Category	LED State	Status		Probable Cause/Solution
			SAM	STM	
Peer LCC status, temperature and voltage are Not Available	Major Warning	none	Selected LCC: Firmware mismatch and Peer LCC: Not Available	Both LCCs: Non-critical	Firmware on LCC A and LCC B are different versions.
		none	Not Available	Not Available	Internal bus is faulty. Contact HP technical support to replace backplane.

5**REMOVAL AND REPLACEMENT**

Disk or Filler

GBIC

LCC

Fan

Power Supply

Disk System

Door

Top Cover (HP-Qualified Only)

Backplane/Mezzanine (HP-Qualified Only)

Caution Do not remove hot-pluggable components until you have the replacement parts and are ready to install them. An empty slot will cause uneven cooling and eventual overheating.

Disk or Filler

Add or replace disks to increase storage capacity or eliminate faults. (See chapter 4 for troubleshooting procedures.) Disks must be Fibre Channel and 3.5 inches wide but can vary in capacity. For current information about supported disks, consult an HP sales representative.

You do not need to turn off the disk system to replace a disk or filler, but you may need to perform system administration.

System Administration

Removing or replacing a disk has consequences for the file systems and logical volumes located on the disk. Before removing or replacing a disk, complete the appropriate system administration for your environment and configuration.

- For HP-UX Ver. 11.0, use SAM to manage strict mirrored volumes
- For HP-UX Ver. 10.20, use HP-UX commands to determine the status of the physical volume and to recreate mirrored extents.

Procedures follow. For additional information, refer to your HP-UX guide, *How HP-UX Works: Concepts for the System Administrator*.

Caution Follow the correct HP-UX procedure to manage logical volumes for the specific environment and configuration of the failed disk.

HP-UX Ver. 11.0, Strict Mirror

When a disk is a member of a “strict” mirrored volume in HP-UX 11.0, you can use SAM to split logical volumes before replacing the disk. SAM prepares a mirrored volume for disk replacement by:

-
- Removing the disk from the volume group
 - Sending a command to the disk system to bypass the disk on the Fibre Channel loop
 - Flashing the disk LED at a slow steady rate to help you physically identify it
 - Rebuilding and syncing the mirror with the new disk

Note You need to know the disk hardware path to complete this procedure.

1. Run SAM.
2. Select **Disk and File Systems**, then select **Disk Devices**.
3. On the Disk Devices screen, select the disk to be replaced by its hardware path. A confirmation dialog asks, “Should SAM prepare the drive for replacement now?”
4. Select **Yes** to prepare the disk for replacement. SAM removes the disk from the logical volume and Fibre Channel loop, starts flashing the LED, and waits for confirmation that the disk has been replaced.
5. Physically remove and replace the faulty disk (see page 113).
6. After the disk has been replaced, select **Yes** to close the confirmation window. SAM disables the loop bypass, turns off the flashing LED, runs IOSCAN to make sure the new disk is available, and restores the volume group and mirror configuration.

Selecting **No** causes SAM to attempt to restore the disk to its original state.

HP-UX Ver. 10.20, Strict Mirror

Use LVM commands to manage data when you replace a mirrored disk on an HP-UX 10.20 host.

Preconditions

- All of the extents of the disk to be replaced must belong to mirrored logical volumes created with the strict (-s) option.
- You must have a current volume group configuration backup file. In version 10.20 and later, the backup is created by default each time an LVM command changes the LVM configuration.
- The capacity of the replacement disk must be the same or greater than the capacity of the disk being replaced.

Before you replace the disk

1. Determine the physical location and the device file name of the disk to be replaced.

If you know the hardware path, obtain the device file name by entering:

```
# ioscan -fn -H <hardware path>
```

For example:

```
# ioscan -fn H 8/4.8.0.0.0.0.0
```

Device and raw device file names are in the third line of the resulting output; for example, /dev/dsk/c21t0d0 and /dev/rdisk/c21t0d0 below.

```
Class      I   H/W Path                Driver      S/W State  H/W Type  Description
-----
disk      116 8/4.8.0.0.0.0.0        sdisk      CLAIMED   DEVICE    SEAGATE ST39102FC
                               /dev/dsk/c21t0d0    /dev/rdisk/c21t0d0
```

If you know the device file name, you can determine the physical path by entering:

```
# lssf <device file>
```

For example:

```
# lssf /dev/dsk/c21t0d0
```

Output shows the physical path as the “address”:

```
sdisk card instance 21 SCSI target 0 SCSI LUN 0 section 0 at address
8/4.0.0.0.0 /dev/dsk/c21t0d0
```

2. Identify the volume group that the physical device belongs to. For example, enter:

```
# strings /etc/lvmtab
```

Output lists the device files after the volume group name. In the example below, /dev/dsk/c21t0d0 is in volume group /dev/vg01:

```
/dev/vg00
/dev/dsk/c0t0d0
/dev/vg01
/dev/dsk/c21t0d0
/dev/dsk/c21t0d1
```

3. Verify the expected status of the target device. Enter:

```
# vgdisplay <volume group>
```

For example:

```
# vgdisplay /dev/vg01
```

If the volume group is active, the following messages will indicate problems with the disk (i.e., physical volume):

```
vgdisplay: Warning: couldn't query physical volume "/dev/dsk/
c21t0d0": The specified path does not correspond to physical volume
attached to this volume group
```

```
vgdisplay: Warning: couldn't query all of the physical volumes.
```

The following messages indicate the volume group is inactive:

```
vgdisplay: volume group not activated.
```

```
vgdisplay: cannot display volume group /dev/vg01
```

After you replace the disk

1. Verify that the new disk is CLAIMED in IOSCAN output. Enter:

```
# ioscan -fn
```

2. Restore LVM structures to the new disk from the backup configuration. Enter:

```
# vgcfgrestore -n <volume group> <raw device file>
```

For example:

```
# vgcfgrestore -n /dev/vg01 /dev/rdisk/c21t0d0
```

3. Attach the disk to the volume group. Enter:

```
# vgchange -a y <volume group>
```

For example

```
# vgchange -a y /dev/vg01
```

4. Watch the disk LEDs for evidence of syncing activity; in other words, that data is being restored on the new disk. If there is no LED activity, check logical volume status by entering:

```
# lvdisplay -v <logical volume>
```

For example:

```
# lvdisplay -v /dev/vg01/lvol1
```

The status of logical extents should change from “stale” to “current” as you repeat this command.

5. If logical volumes are not automatically syncing, enter the command to sync all logical volumes in the volume group:

```
# vgsync <volume group>
```

For example:

```
# vgsync /dev/vg01
```

6. Repeat step 7 to verify that logical extents are “current.”

Using STM to Flash LEDs

STM’s Expert Tool includes an option to flash the LED associated with specific disk slots. This function is automatic in SAM. Enter the password to install the HP-Only license before using the Expert Tool.

Flash the desired LED as follows:

1. With the HP-Only license installed, select the desired disk system.
2. Select **Expert Tool > Run** from the **Tools** menu. An Expert Tool window opens.
3. Select **Disk LED On** from the **Utility** menu. STM displays a the slot number (0-9), the loop ID (address), and the status of each disk in the disk system (see Figure 41).
4. Type the slot number of the target disk in the **Slot** field and click **OK**. The amber LED associated with the slot begins flashing at a slow steady rate. If the LED is already on, it remains on.

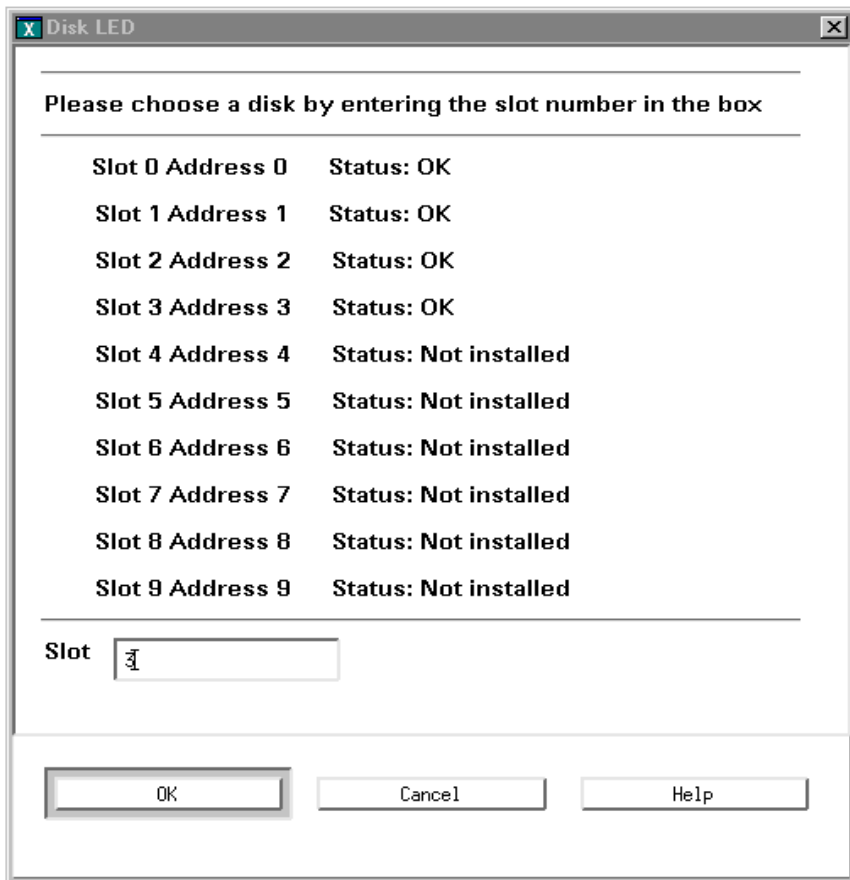

Figure 41 STM Disk LED Window

Turn off the flashing LED as follows:

1. If the Expert Tool is no longer running:
 - a. Select the desired disk system.
 - b. Select **Expert Tool > Run** from the **Tools** menu.

-
2. Select **Disk LED Off** from the **Utility** menu. STM displays the list of disk slots (0-9) in the disk system (see Figure 41).
 3. Type the slot number of the target disk in the **Slot** field and click **OK**. The LED turns off. If it was already off, it remains off.

Tools

- Small flat-blade screwdriver
- ESD wrist strap

Procedure to Remove a Disk or Filler

Caution To prevent damage from static electricity, follow standard ESD procedures and avoid touching exposed circuitry.



Do not remove a disk or filler from an operating product until you have the replacement part and are ready to install it. An empty slot will cause uneven cooling and eventual overheating.

1. Unlock and open the disk system door.
2. Insert the plug of your static wrist strap into the disk system ESD socket (A in Figure 42).

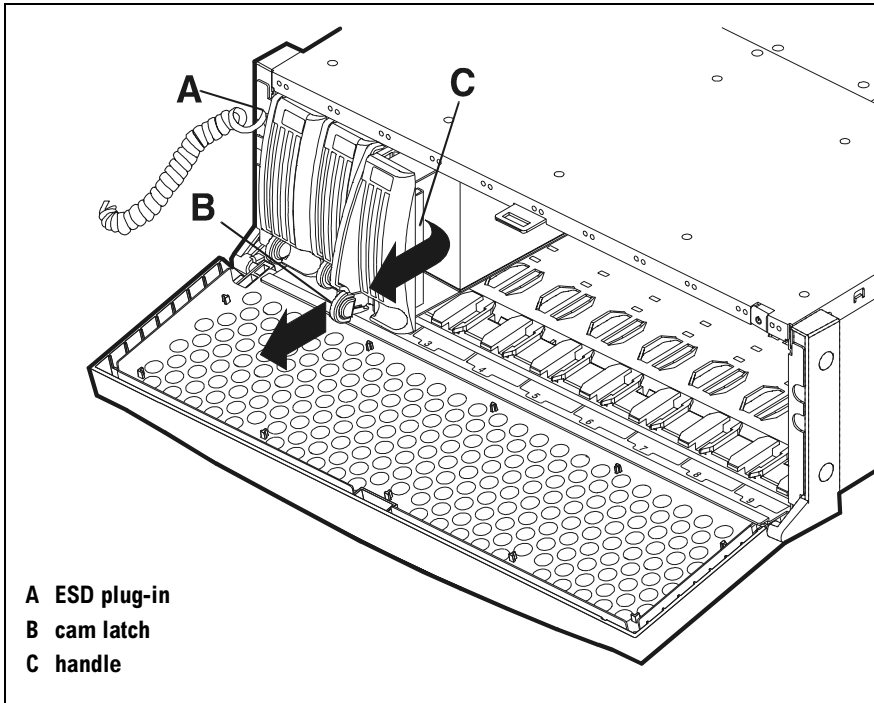

Figure 42 Disk Removal

3. If you are removing a filler, pull out the filler and skip to Step 6.
If you are removing a disk, continue with Step 4.

Caution Spinning disks generate heat and gyratory force. Wait for a spinning disk to slow down and cool off before completely removing it from the disk system.



4. Squeeze the disk latch tab (B) and pull the latch toward you just enough to disconnect the disk from the backplane.

WARNING **High current available. Avoid touching the backplane or adjacent drive electronics when removing and inserting disks.**

5. When the disk has spun down, remove it from the slot, using the latch to pull the disk until the handle (C) is exposed enough to grasp.

Caution If the disk will be reused, place it on a static mat or other ESD-protected surface.

Replace the disk or filler immediately (see below).

Procedure to Replace a Disk

Caution Follow standard ESD procedures and avoid touching exposed circuitry. Touching the disk circuit board can cause high energy discharge and permanently damage the disk.



Disks are fragile. Handle carefully.



1. Remove the replacement disk from its ESD bag, being careful to grasp the disk by its handle (A in Figure 43).

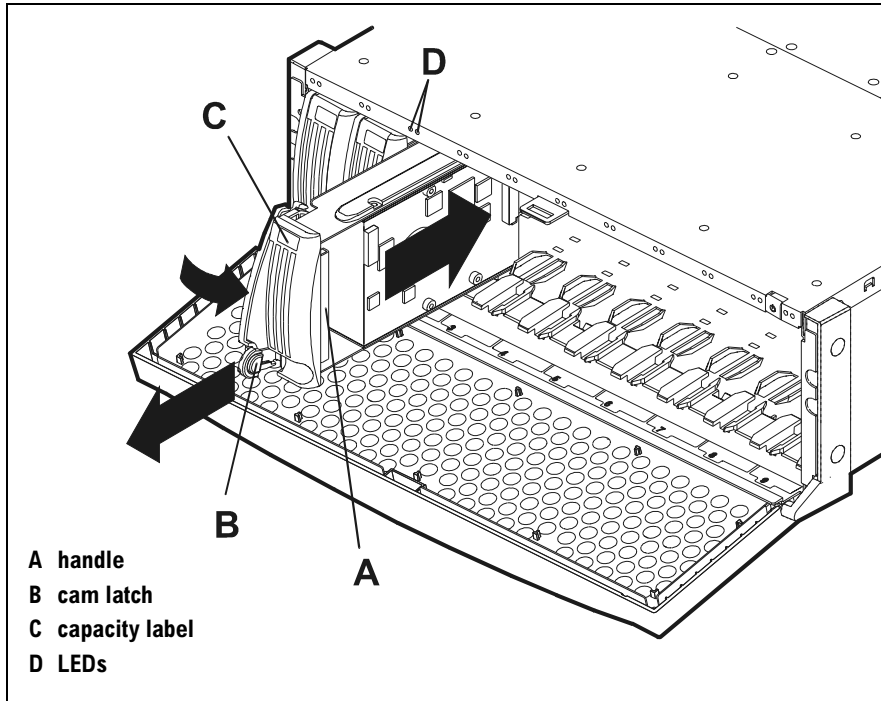

Figure 43 Disk Installation

2. Pull the cam latch (B) away from the disk.

Note For safe insertion, use two hands to hold the disk — one on the handle and the other on the carrier frame.

3. Slide the disk, capacity label up (C), into the empty slot.
4. Close the cam latch to seat the disk firmly on the backplane. An audible click indicates the latch is closed.

5. Monitor the LEDs (D).

Both LEDs should turn on briefly. Then the amber LED turns off and the green LED blinks, slowly at first and then quickly. Finally, the green LED stays on. If the amber LED remains on, refer to chapter 4, Troubleshooting, for possible causes and remedies.

6. Unplug your ESD strap and close and lock the disk system door.

7. Run IOSCAN on the host to verify that the replacement disk is CLAIMED.

8. Restore file systems and data as needed (see *After you replace the disk*, page 110).

GBIC

Replace a GBIC when troubleshooting indicates a faulty GBIC (see *Isolating Causes*, page 99). You will also replace or move GBICs when you replace an LCC.

In high availability configurations, you can replace GBICs without affecting I/O operations. If the GBIC is the only data path to the disk system, however, all disks in the system will be inaccessible while the GBIC is disconnected.

Tools

- None required

Procedure

1. Unplug the fiber optic connector (A in Figure 44) from the GBIC.
2. Unlatch and remove the GBIC (B) from the LCC. The GBIC should pull out easily.
3. Insert the replacement GBIC, pins first, into the metal port slot (C). If the GBIC resists insertion, it may be upside down.
4. Plug in the cable (A), matching top and bottom with the GBIC.
5. Verify that the Rx Ready LED (D) is green. If not, refer to chapter 4, *Troubleshooting*.

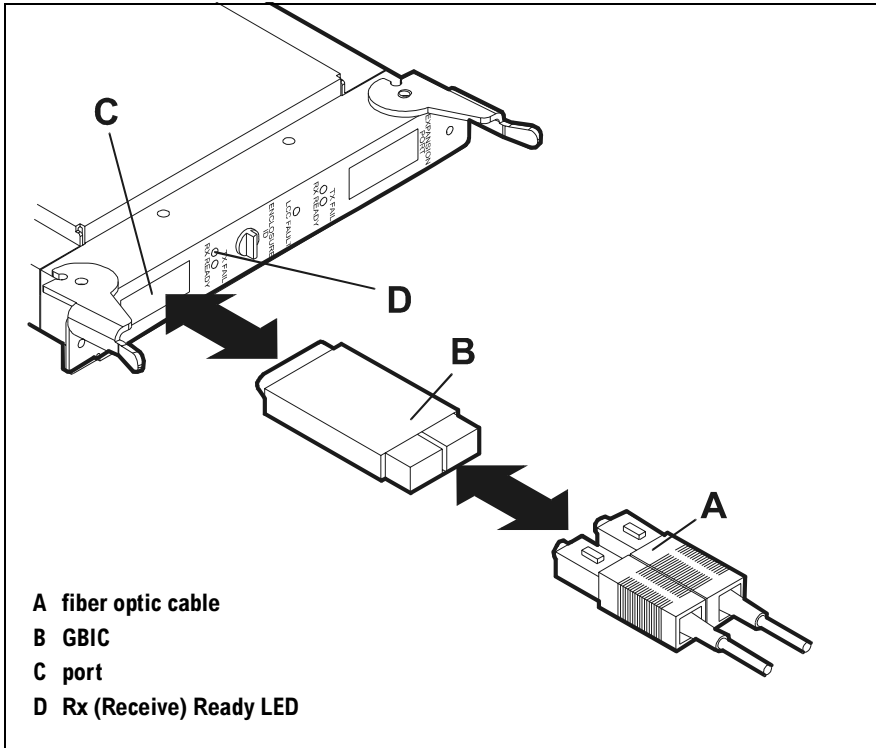

Figure 44 GBIC Removal and Replacement

LCC

Replace an LCC when troubleshooting shows the card is faulty (see *Isolating Causes*, page 99).

In high availability configurations, there is no need to terminate I/O or turn off the disk system to remove and replace an LCC. If, on the other hand, you are replacing the only LCC in use, then all disks will be inaccessible for I/O during the operation. In this case refer to *System Administration*, page 106.

Caution Touching the LCC pins can cause high energy discharge and permanently damage the LCC.



Tools

- Torx T15 or flat-blade screwdriver
- ESD wrist strap

Procedure

Caution Do not remove an LCC from an operating product until you have the replacement LCC and are ready to install it. An empty slot will cause uneven cooling and eventual overheating.

1. Attach the clip end of your ESD wrist strap to the ground stud at the top of the rack.
2. Remove cables and GBICs (A in Figure 45) from the failed LCC (see page 118).

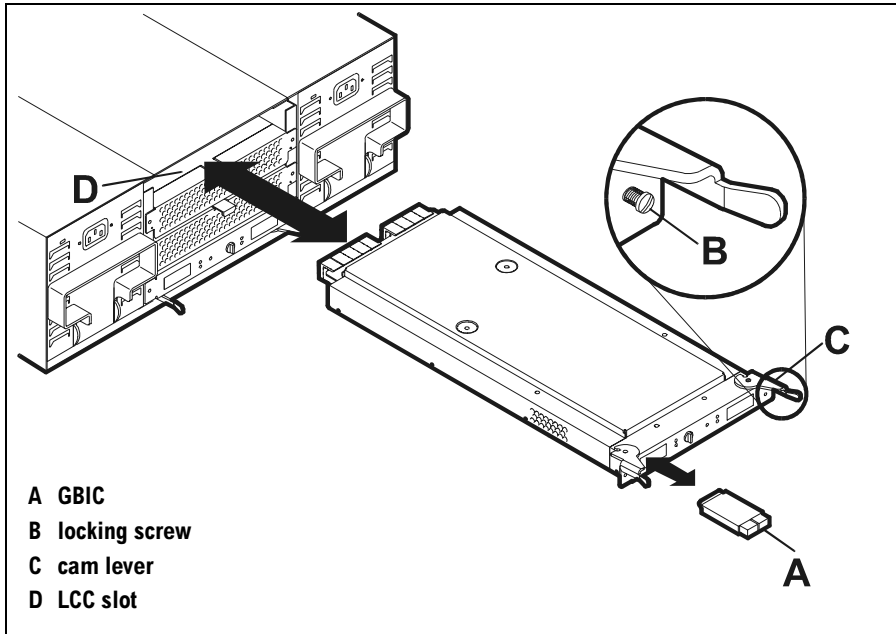

Figure 45 LCC Removal and Replacement

3. Loosen the two locking screws (B) until they clear the chassis. The screws stay in the card.
4. Open the cam levers (C) by pulling them away from the center of the card. This disconnects the LCC pins from the backplane.
5. Pull the LCC out of the slot (D).

Replace the LCC immediately if the product is in use (see next step).

Caution Touching the LCC pins can cause high energy discharge and permanently damage the LCC.



6. Remove the replacement LCC from its ESD bag.
7. Set the Enclosure ID (A in Figure 46) to the Enclosure ID (0–9) on the peer LCC.

Caution If the Enclosure IDs on peer LCCs are different and the master LCC fails or is taken off the loop, the second LCC will assign different addresses to the disks. Data in outstanding I/O requests may be lost.

8. Open the cam levers (see Figure 45) by pulling them away from the center of the card.
9. Insert the LCC in the empty slot. The perforated side of the card faces down in the top slot, up in the bottom slot.
10. Push the cam levers flat against the center of the card to seat the LCC pins firmly on the backplane.
11. Watch the LCC Fault LED (B in Figure 46). It should come on briefly and then turn off. If the LED is on and a buzzer sounds, the Enclosure ID does not match the peer's. For other solutions to an LCC fault, see Isolating Causes, page 99.
12. Tighten the locking screws (B in Figure 45).
13. Reinstall the GBICs and fiber cables (see page 118).

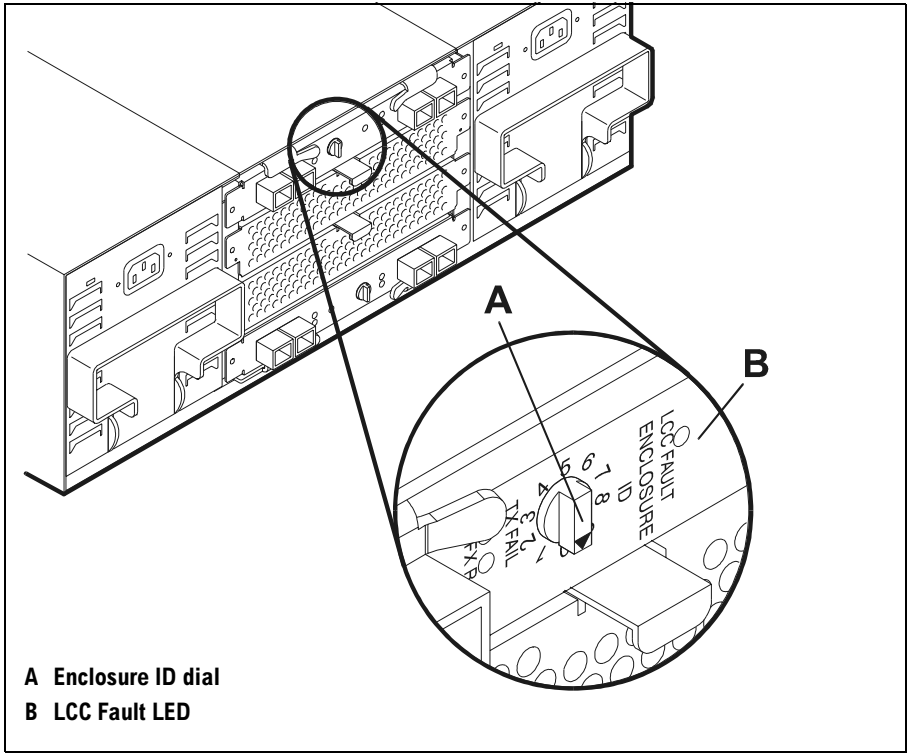

Figure 46 Enclosure ID and LCC Fault LED

Fan

Replace a fan as soon as possible upon determining a fan failure (see chapter 4, Troubleshooting). Fans are redundant so that when one fan fails, the other fan maintains proper cooling. However, if the remaining fan fails before the first fan is replaced, the disk system must be turned off to prevent heat damage.

You do not need to turn off the disk system to replace a fan.

Tools

- Torx T15 or flat-blade screwdriver

Procedure

Caution Do not remove a fan from an operating product until you have the replacement fan and are ready to install it. An empty slot will cause uneven cooling and eventual overheating.

1. Loosen the two locking screws (A in Figure 47) until they clear the chassis. The screws stay with the fan.
2. Pull the fan out of the chassis by the pull tab (B).
Replace the fan immediately if the product is in use (procedure follows).
3. Insert the replacement fan into the empty slot (C in Figure 47).
4. Monitor the fan LED. It should flash amber and then turn green. If the LED is not green, refer to chapter 4, Troubleshooting.
5. Tighten the locking screws (A).

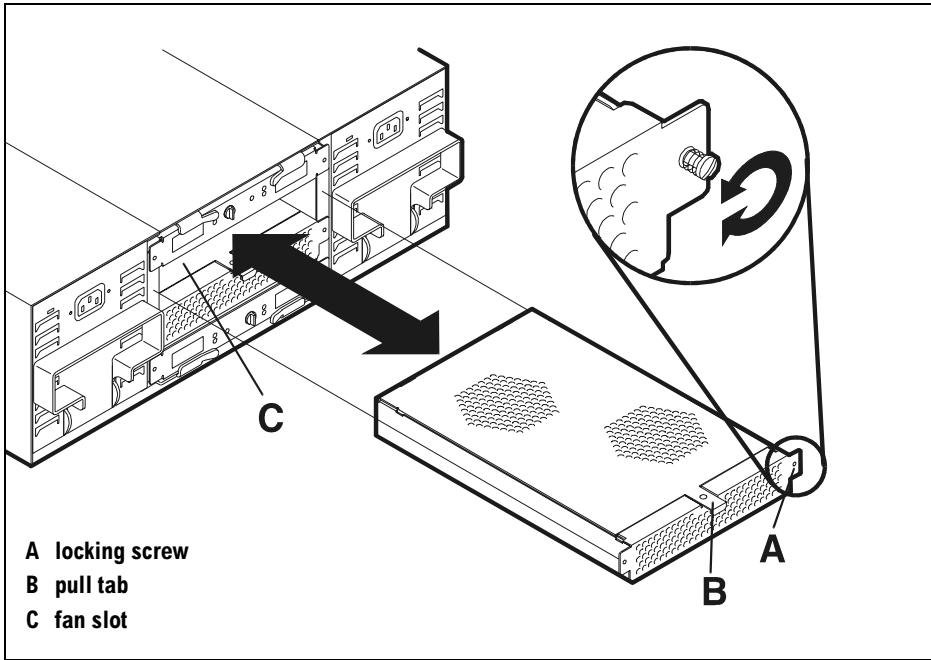

Figure 47 Fan Removal and Replacement

Power Supply

Replace a power supply as soon as possible when troubleshooting indicates a power supply failure (see *Isolating Causes*, page 99). When a power supply fails, the remaining power supply provides proper voltage to the disk system. However, if the remaining power supply fails before the first power supply is replaced, the disk system will turn off.

You do not need to turn off the disk system to replace a power supply.

Tools

- Torx T15 or flat-blade screwdriver

Procedure

Caution Do not remove a power supply from an operating product until you have the replacement and are ready to install it. An empty slot will cause uneven cooling and eventual overheating.

1. Disconnect the power cord from the power supply.
2. Loosen the screw (B in Figure 48) from the power supply handle (A).
3. Pull the handle down to disengage the power supply from the backplane.
4. Pull the power supply out of the chassis. Support the far end of the supply with your free hand as it clears the chassis.

Replace the power supply immediately if the product is in use (see next step).

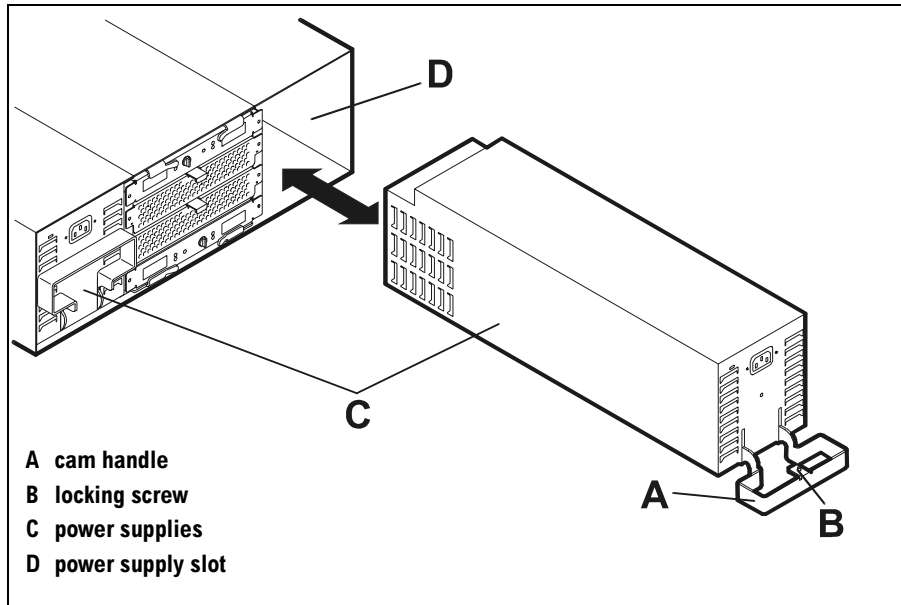

Figure 48 Power Supply Removal and Replacement

5. With the handle down, slide the replacement power supply into the empty slot (D in Figure 48). The supply begins to engage the backplane with $\frac{3}{8}$ inch (8 mm) still exposed.
6. Rotate the handle up to draw the power supply the last $\frac{3}{8}$ inch into the chassis and firmly seat the power supply on the backplane. The power supply should be flush with the chassis.
7. Tighten the screw (B) in the power supply handle (A).
8. Plug the power cord into the power supply and electrical source.
9. Monitor the power supply LED. It should flash amber and then turn green. If the LED is dark or stays amber, see chapter 4, Troubleshooting.

Disk System

Use this procedure if you need to move or remove and then replace the disk system in the rack. For example, you need to move the disk system forward on the rails in order to replace the door, backplane, or mezzanine.

Tools

- Torx T25 screwdriver
- Small flat-blade screwdriver

Procedure to Remove a Disk System

1. Determine the file systems that will be inaccessible for I/O operations while the disk system is off, and perform necessary system administration. (See the HP-UX guide, *How HP-UX Works: Concepts for the System Administrator*.)

Note You can maintain I/O access to daisy-chained products by moving the cable from the expansion port of the damaged disk system to an active Fibre Channel source. (See Step 5.)

2. Use the flat-blade screwdriver to unlock and open the disk system door (see Figure 51).

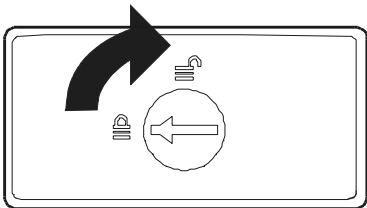

Figure 49 Door Lock

3. Press and release the power button to turn off the disk system.
4. If needed, remove disks and fillers at this time; for example, you need to remove disks and fillers if you will be removing the top cover. See disk removal steps 2 through 7 on page 113

Note Removing disks and fillers from right to left improves access to successive disks.

5. Remove the screws from the mounting ears (E in Figure 51).
6. Close and lock the door.
7. At the back of the disk system, disconnect power cords and fiber cables.

If products are daisy-chained, move the cable from the expansion port of the damaged disk system to the expansion port that is currently occupied by the cable to the primary port of the damaged disk system (see Figure 50).

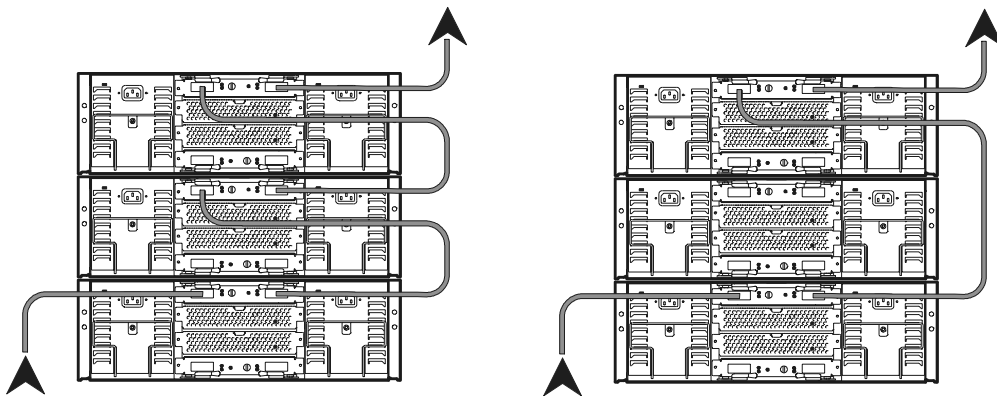

Figure 50 Before and After Disconnecting a Disk System in a Daisy Chain

WARNING Product is heavy (~80 lbs. without disks). If you need to remove the disk system from the rack, use two people or a lift device.

-
8. Push the disconnected disk system forward 2 to 10 inches, or lift it completely out of the rack, as needed.

Procedure to Replace a Disk System

1. When you are ready to replace the disk system, push the disk system back into the rack.
2. Unlock and open the door.
3. Insert and tighten the front mounting screws.
4. If disks and fillers were removed, reinstall them at this time. See steps 6 through 9 on page 115.
5. Reconnect data cables and power cords at the back of the disk system, restoring the daisy chain as needed.
6. Return to the front and open the disk system door.
7. Press the power button to turn on the system.
8. Watch the disk and system LEDs for activity. If an amber light remains on for more than a couple seconds, begin troubleshooting.
9. When the disk system is operational, perform necessary system administration to return file systems to service.

Door

The front door is required for regulatory compliance. Replace the door immediately if it is damaged.

The procedure for replacing the door involves moving the disk system. Therefore, to eliminate the possibility of inadvertently pulling out live cables and causing an unplanned shutdown, HP recommends turning the power off and disconnecting power and data cables before removing and replacing the door.

Caution Turning off a disk system terminates the Fibre Channel loop at that node, isolating the disks in the immediate disk system and in any other disk systems that are linked to its expansion port.

Tools

- Torx T25 screwdriver
- Small flat-blade screwdriver

Procedure

1. Perform steps 1 through 7 on page 128 to move the disk system 2 to 3 inches forward in the rack.
2. With the door closed, remove two screws from each hinge block (C in Figure 51).
3. Pull the hinge blocks straight out from the sides of the product, letting the latch hold the door in place.
4. Supporting the door with one hand, unlock and remove the door.

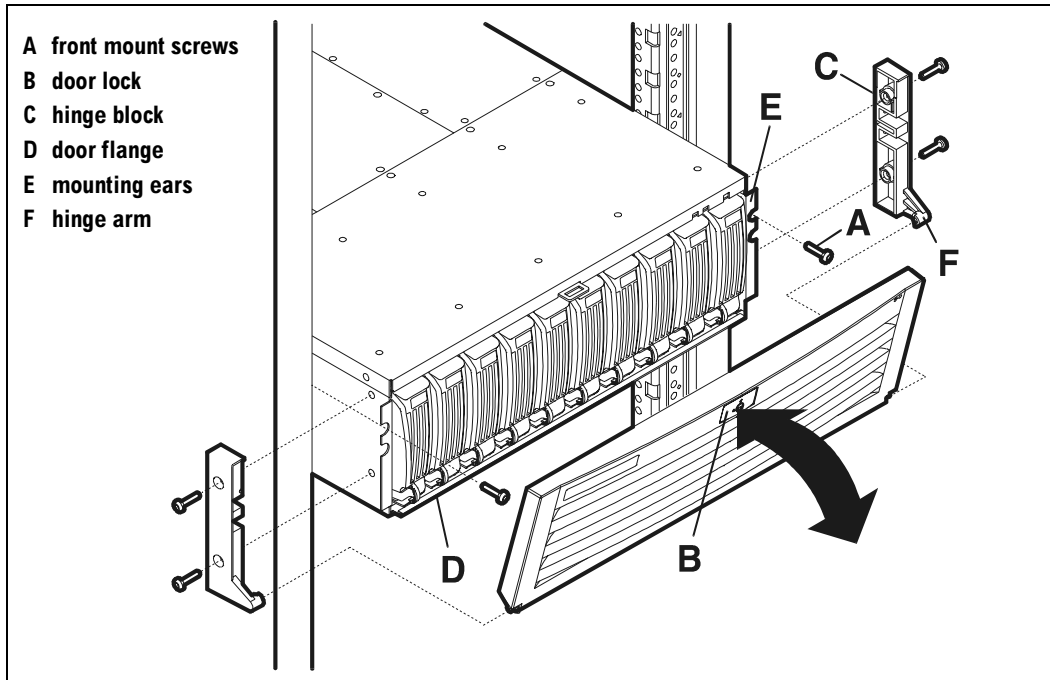

Figure 51 Door Removal and Replacement

5. To replace the door, insert the bottom flange (D) of the disk system chassis between the gasket and bottom edge of the new door.
6. Close and lock the door, letting the latch hold the door.
7. Insert the right and left hinge blocks behind the disk system mounting ears (E), lining up all holes and inserting the hinge arm (F) over the pin on the bottom of the door.
8. Insert and tighten two screws through each hinge block and disk system chassis.
9. Perform steps 8 through 15 on page 130 to reattach the disk system to the rack.

Top Cover (HP-Qualified Only)

The following procedure is for HP-qualified personnel only.

The top cover (not a replaceable part) must be removed in order to replace the backplane or mezzanine board.

Because the procedure involves moving the disk system, HP recommends turning the power off and disconnecting all cables before removing the top cover.

Caution Turning off a disk system terminates the Fibre Channel loop at that node, isolating the disks not only in the immediate disk system but also in any disk system linked to its expansion port.

Tools

- Small flat-blade screwdriver
- Torx T25 screwdriver
- Torx T10 screwdriver

Procedure to Remove the Top Cover

1. Move the disk system forward 10 inches, or remove the disk system entirely. See Procedure to Remove a Disk System, page 128 and be sure to include the step for removing disks.

Caution Removing the top cover with the power button in the ON position can damage the internal switch.

Caution Disk slots must be empty before removing the top cover.

2. Remove the nine Torx T10 screws from the back and side edges of the cover plate (A in Figure 52). Screws are marked by a star pattern in the sheet metal.

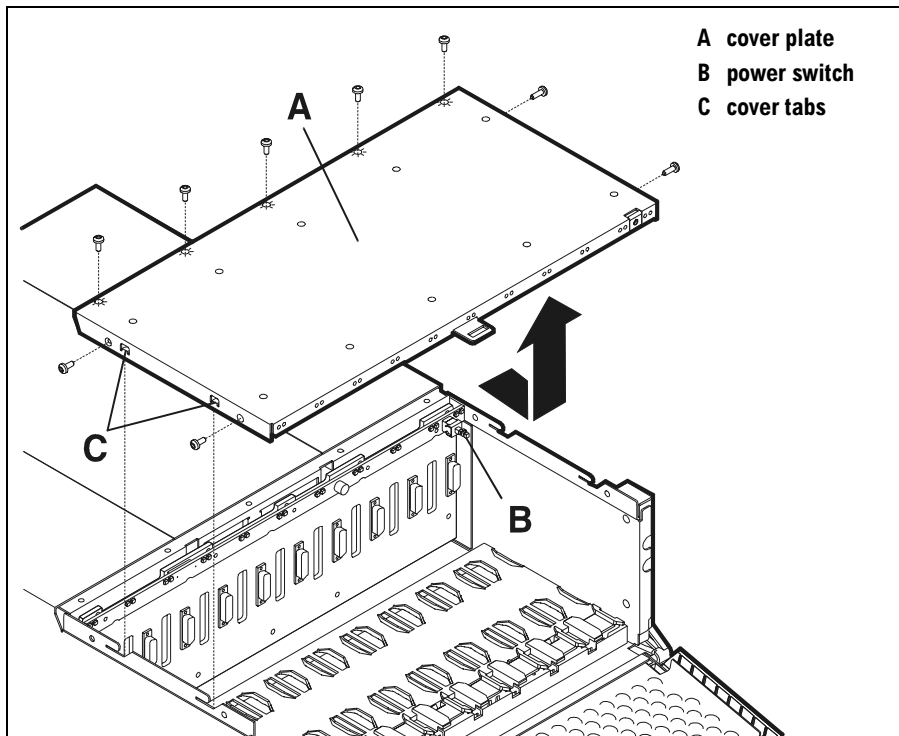

Figure 52 Top Cover Assembly

3. Slide the cover forward about one inch; then lift up and out of the product.

Procedure to Replace the Top Cover

1. When you are ready to replace the cover, set the cover on the chassis so that the tabs (C in Figure 52) settle into the slots in the upper edge of the chassis.
2. Slide the cover to the middle of the chassis. The push rod automatically engages the internal switch (B in Figure 52).
3. Insert and tighten the Torx T10 screws along the back and side edges of the cover.
4. Follow the steps to replace the disk system on page 130.

Backplane/Mezzanine (HP-Qualified Only)

The backplane and mezzanine boards are replaceable by HP-qualified personnel only.

Replace the backplane when troubleshooting determines it is the source of the problem (see “Isolating Causes” in chapter 4). Disks, LCCs, fans, and power supplies connect to the backplane. The backplane also contains the mezzanine board, which can be replaced independently if it is damaged or broken. The mezzanine contains the power switch.

The power must be OFF and the top cover removed in order to remove and replace the backplane or mezzanine board.

Caution Turning off a disk system terminates the Fibre Channel loop at that node, isolating the disks not only in the immediate disk system but also in any disk systems that are linked to its expansion port.

Tools

- Small flat-blade screwdriver
- Torx T25 screwdriver
- Torx T15 screwdriver
- Torx T10 screwdriver

Procedure

1. Remove the top cover (see procedure on page 133).
2. If you are removing only the mezzanine:
 - a. Remove the five Torx T10 screws securing the mezzanine to the backplane (see Figure 53).
 - b. Pull the mezzanine board free of its connector (C) on the backplane.

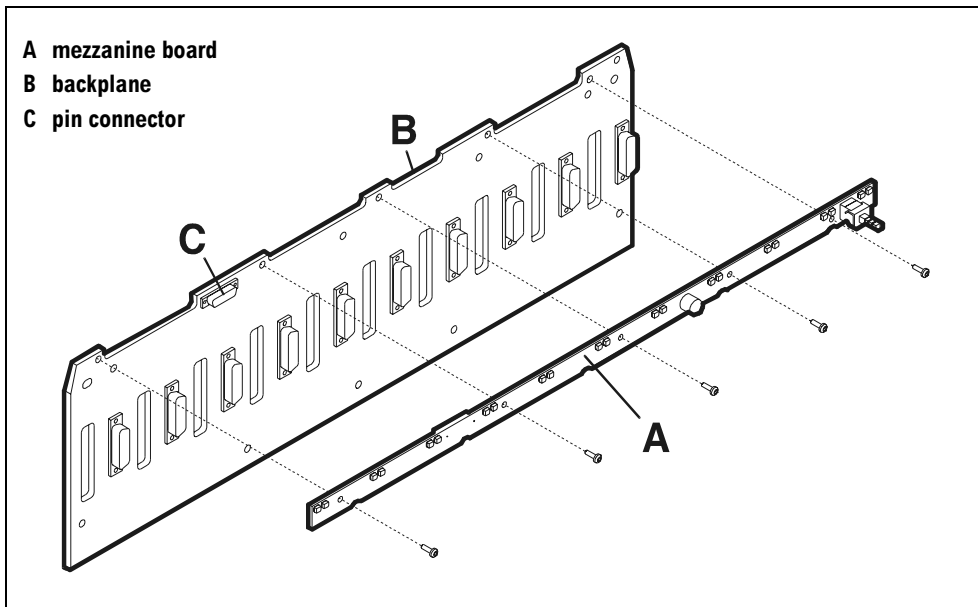

Figure 53 Mezzanine Assembly

-
3. If you are removing the backplane:
 - a. Remove locking brackets and pull power supplies free of the backplane (see page 126).
 - b. Loosen locking screws, open extractors, and pull LCCs free of the backplane (see page 120).

Note There is no need to loosen the fans.

- c. Remove the ten Torx T15 screws along the top and bottom edges of the backplane (see Figure 54).
 - d. Pull the backplane forward to clear alignment pins (B) and lift backplane up and out of the disk system.
4. To replace the backplane:
 - a. Stand the new backplane inside the chassis and push it over the alignment pins (B in Figure 54). Connectors automatically align with floating fan connectors inside the chassis.
 - b. Insert and tighten ten screws into the backplane and chassis.
 - c. Reseat and secure the LCCs (see steps 7 through 10 on page 122).
 - d. Reseat and secure the power supplies (see steps 5 through 8 on page 127).
5. To replace the mezzanine:
 - a. Attach the new mezzanine to the backplane connector (C in Figure 53).
 - b. Insert and tighten five Torx T10 screws through the mezzanine and into the backplane.
6. Replace the top cover and reinstall the system (see procedure on page 135).

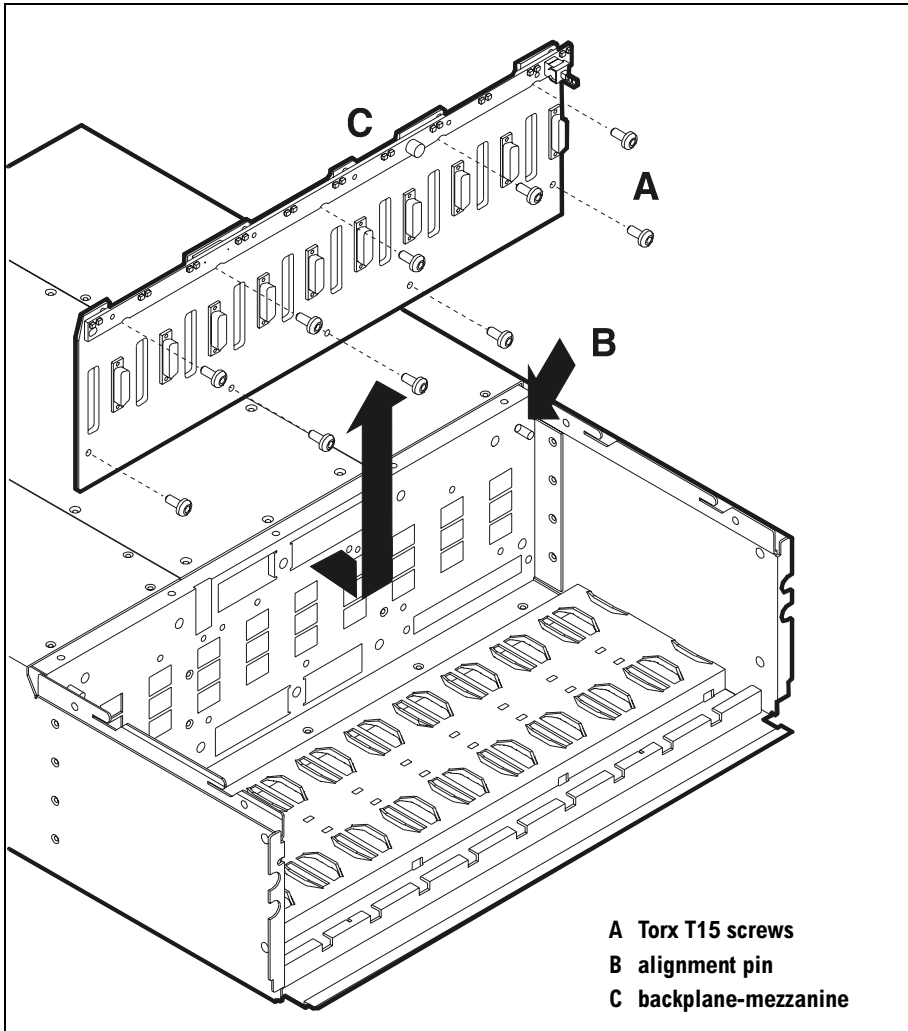

Figure 54 Backplane Assembly

Product Models and Options

Replaceable Parts

Hardware/Software Requirements

Specifications

Regulatory Statements

Product Models and Options

The HP SureStore E Disk System FC10 has two models:

- A5236A field-racked (by HP-qualified service engineers)
- A5236AZ factory-racked

Options, shown in Table 16, include a GBIC, various disk packs, and, for the factory racked model, several lengths of fiber optic cables. Order cables separately 308for the field-racked model.

Table 16 Product Options

Option	Description
001	1 GBIC fiber optic, shortwave (Required)*
104	4 9-Gbyte 10K Fibre Channel hard disk drives
108	8 9-Gbyte 10K Fibre Channel hard disk drives
110	10 9-Gbyte 10K Fibre Channel hard disk drives
204	4 18-Gbyte 10K Fibre Channel hard disk drives
208	8 18-Gbyte 10K Fibre Channel hard disk drives
210	10 18-Gbyte 10K Fibre Channel hard disk drives
304	4 36-Gbyte 10K Fibre Channel hard disk drives
308	8 36-Gbyte 10K Fibre Channel hard disk drives
310	10 36-Gbyte 10K Fibre Channel hard disk drives
OZ4	2-meter fiber optic cable (A5236AZ only)
AFY	16-meter fiber optic cable (A5236AZ only)
OZ5	50-meter fiber optic cable (A5236AZ only)
OZ6	100-meter fiber optic cable (A5236AZ only)

* Option 001 is required and provides one GBIC. To receive four GBICs, order Option 001 with a quantity of four.

Upgrade Products

Order the following parts to augment or reconfigure your original purchase:

Table 17 Upgrade Products

Order No.	Description
A5235A	1 9-Gbyte 10K Fibre Channel hard disk drive
A5234A	1 18-Gbyte 10K Fibre Channel hard disk drive
A5596A	1 36-Gbyte 10K Fibre Channel hard disk drive
A5245A	GBIC, fiber optic, shortwave
A3583A	2-meter fiber optic cable, shortwave
A3531A	16-meter fiber optic cable, shortwave
A3735A	50-meter fiber optic cable, shortwave
A3736A	100-meter fiber optic cable, shortwave
A5250A	Rail kit for HP C2785A, C2786A, C2787A, A1896A, and A1897A
A5251A	Rail kit for HP Rack System/E: HP A4900A, A4901A, A4902A

PDU/PDRU Products

Hewlett-Packard offers the following PDUs and PDRUs, with US and international power options, for meeting disk system electrical requirements:

Table 18 PDU/PDRU Products

Order No.	Description
E7676A	19 inch, 100-240 V, 16 Amp, 1 C20 inlet, 10 C20 outlets
E7671A	19 inch, 100-240 V, 16 Amp, 1 C20 inlet, 2 C19 & 6 C13 outlets
E7674A	19 inch, 100-240 V, 16 Amp, 1 C20 inlet, 1 C19 & 7 C13 outlets
E7679A	19 inch, 100-127 V, 16 Amp, 2 C20 inlets, 2 C19 outlets, switch accessory
E7680A	19 inch, 200-240 V, 16 Amp, 2 C20 inlets, 2 C19 outlets, switch accessory
E7681A	19 inch, 200-240 V, 30 Amp, L6-30P, 2 C19 & 8 C13 outlets, switch accessory
E7682A	19 inch, 200-240 V, 30 Amp, IEC-309, 2 C19 & 2 C13 outlets, switch accessory
E4452A	36 inch, 220 V, 16 Amp, L6-20P, 6 C-13 outlets
E4453A	36 inch, 220 V, 16 Amp, no plug, 6 C-13 outlets
E5933A	36-inch, 110-220 V, 16 Amp, UPS, IEC-320, 10 C-13 outlets
E4456A/B	60 inch, 220 V, 16 Amp, L6-20P, 10 C-13 outlets
E4457A/B	60 inch, 220 V, 16 Amp, no plug, 10 C-13 outlets
E5930A	60 inch, 110-220 V, 16 Amp, UPS, IEC-320, 10 C-13 outlets
E5931A	60 inch, 220 V, 16 Amp, UPS, LP-30P, 10 C-13 outlets
E5932A	60 inch, 220 V, 16 Amp, UPS, no plug, 10 C-13 outlets
E7677A	Switch panel accessory for PRU
E7678A	Switch control jumper cord for PRU

Replaceable Parts

Order the following parts for field replacement:

Table 19 Replacement and Exchange Part Numbers

Replacement Part Order No.	Exchange Part Order No.	Part Description
0588-001MH		20 top cover screws 6-32x3/16 T10
8120-6514		Power cord
A5236-60019		Fan cable
A5236-60030		Door assembly
A5236-60023	A5236-69023	Power supply
A5236-60022		Backplane and mezzanine assembly
A5236-60021		Mezzanine board
A5236-60003		Fan
A5244-60001	A5244-69001	Link Control Card (LCC)
1005-0389		GBIC (fiber optic, shortwave)
A5236-40024		Disk filler
A5250-60001		Rail kit, E3660 series
A5251-60001		Rail kit, Rack System/E
A5235-60001	A5235-69001	9 GB LP disk
A5234-60001	A5234-69001	18 GB HH disk
A5596-67001	A5596-69001	36 GB HH disk

Hardware/Software Requirements

The disk system is supported on HP systems running the following operating systems:

- HP-UX 10.20 TFC
- HP-UX 11.00
- HP-UX 11.00 ACE (S700 only)

Such systems include:

- D-class
- K-class
- T600
- V-class
- J5000
- C3000

Specifications

Dimensions

The maximum dimensions of the disk system with the door and power supply handles closed are as follows:

- Height: 15.0 cm (5.91 in.)
- Width: 48.0 cm (18.90 in.)
- Depth: 69.1 cm (27.20 in.)

Weight

A fully loaded disk system weighs approximately 110 pounds. Component weights are shown in Table 20.

Table 20 Product Weights

Component	Weight of Each (lbs)	Quantity	Subtotal (lbs)
Disk Drive (HH)	2.9	10	28
Fan	3.3	2	7
Power Supply	10.6	2	22
LCC	4.5	2	9
Midplane-Mezzanine	6	1	6
Door	2	1	2
Chassis	35	1	35
Approx. Total			110 lbs

AC Power Input

The disk system typically operates at 100-127 and 200-240 V AC with 4.8 amps over the low voltage range and 2.4 amps over the high voltage range, 50-60 Hz, single phase, power factor corrected. Maximum amperage is 6.5 over the low voltage range and 3.2 over the high voltage range.

Power Consumption

Table 21 Typical Power Consumption

Incoming Voltage AC RMS	Typical Power Consumption
100 - 127 V AC	478 watts
200 - 240 V AC	467 watts

DC Power Output

- Disk: +5 V and +12 V from power supply
- LCC: +12 V from power supply, +5 V from power supply, 3.3 V self-generated
- Fan: +12 V from power supply

Heat Output

- 2200 BTU/hr.

Environment

The following environmental specifications were type-tested under controlled conditions. Hewlett-Packard maintains an active program of auditing production products to make sure these specifications remain true when products are retested under the same conditions. However, the limits of these specifications do not

represent the optimum for long, trouble-free operation and specifically are not recommended for maximum satisfaction. The recommended conditions are stated when appropriate.

- Operating temperature: 5° C to 40° C (50° F to 104° F)
Recommended: 20° C to 25.5° C (68° F to 78° F)
- Maximum gradient: 20° C per hour (36° F per hour)
- Relative humidity: 20% to 80% noncondensing, max. wetbulb at 26° C
Recommended: 30% to 50% noncondensing
- Altitude: 3000 m (10,000 ft)

Note For continuous, trouble-free operation, the disk system should NOT be operated at its maximum environmental limits for extended periods of time. Operating within the recommended operating range, a less stressful operating environment, ensures maximum reliability.

The environmental limits in a nonoperating state (shipping and storage) are wider:

- Temperature: -40° C to 70° C (-40° F to 158° F)
- Maximum gradient: 24° C per hour (43.2° F per hour)
- Relative humidity: 15% to 90% noncondensing
- Altitude: 4600 m (15,000 ft)

Acoustics

- Sound power: 6.4 Bels
- Sound pressure at operator's position: 56.2 dB(A)

Safety Certifications

UL listed, UL 1950:1995 – 3rd Edition

CSA certified, C22.2 No. 950:1989

TUV certified with GS mark, EN 60950:1992 + A1:1993, A2:1993, A3:1995, A4:1997

CE mark (see Declaration of Conformity on page 156)

EMC Compliance

Australia: AS/NZS 3548, Class A

Canada: ICES-003, Class A

China: CB9254-88

European Union: EN55022 Class A, EN50082-1

Japan: VCCI Class A

Taiwan: CNS 13438, Class A

US: 47 CFR Parts 2 & 15, Class A

Regulatory Statements

A. FCC Statement (For U.S.A. Only)

The Federal Communications Commission (in 47 CFR 15.105) has specified that the following notice be brought to the attention of the users of this product.

This equipment has been tested and found to comply with the limits for a Class A digital device, pursuant to Part 15 of the FCC Rules. These limits are designed to provide reasonable protection against harmful interference when the equipment is operated in a commercial environment. This equipment generates, uses, and can radiate radio frequency energy and, if not installed and used in accordance with the instruction manual, may cause harmful interference to radio communications. Operation of this equipment in a residential area is likely to cause harmful interference in which case the user will be required to correct the interference at his own expense. The end user of this product should be aware that any changes or modifications made to this equipment without the approval of Hewlett-Packard could result in the product not meeting the Class A limits, in which case the FCC could void the user's authority to operate the equipment.

B. IEC Statement (Worldwide)

This is a Class A product. In a domestic environment this product may cause radio interference, in which case the user may be required to take adequate measures.

C. Spécification ATI Classe A (France)

DECLARATION D'INSTALLATION ET DE MISE EN EXPLOITATION d'un matériel de traitement de l'information (ATI), classé A en fonction des niveaux de perturbations radioélectriques émis, définis dans la norme européenne EN 55022 concernant la Compatibilité Electromagnétique.

Cher Client,

Conformément à la Réglementation Française en vigueur l'installation ou le transfert d'installation, et l'exploitation de cet appareil de classe A, doivent faire l'objet d'une déclaration (en deux exemplaires) simultanément auprès des services suivants:

- Comité de Coordination des Télécommunications 20, avenue de Ségur - 75700 PARIS
- Préfecture du département du lieu d'exploitation

Le formulaire à utiliser est disponible auprès des préfetures.

La déclaration doit être faite dans les 30 jours suivant la mise en exploitation.

Le non respect de cette obligation peut être sanctionné par les peines prévues au code des Postes et Télécommunications et celles indiquées dans la loi du 31 mai 1993 susvisée.

Arrêté du 27 Mars 1993, publié au J.O. du 28 Mars - ATI

D. Product Noise Declaration (Germany)

Schalldruckpegel $L_p = 56$ dB(A)

Am Arbeitsplatz (operator position)

Normaler Betrieb (normal operation)

Nach ISO 7779:1988 / EN 27779:1991 (Typprüfung)

E. VCCI Statement (Japan)

この装置は、情報処理装置等電波障害自主規制協議会（VCCI）の基準に基づくクラスA情報技術装置です。この装置を家庭環境で使用すると電波妨害を引き起こすことがあります。この場合には使用者が適切な対策を講ずるよう要求されることがあります。

Harmonics Conformance (Japan)

高調波ガイドライン適合品

F. BCIQ EMC Statement (Taiwan)

警告使用者：這是甲類的資訊產品，在居住的環境中使用時，可能會造成射頻干擾，在這種情況下，使用者會被要求採取某些適當的對策。

Laser Safety

A. Certification and Classification Information

This product contains a laser internal to the GigaBit Interface Converter (GBIC) for connection to the Fibre communications port.

In the USA, the GBIC is certified as a Class 1 laser product conforming to the requirements contained in the Department of Health and Human Services (DHHS) regulation 21 CFR, Subchapter J. The certification is indicated by a label located on the plastic GBIC housing.

Outside the USA, the GBIC is certified as a Class 1 laser product conforming to the requirements contained in IEC 825-1:1993 and EN 60825-1:1994, including Amendment 11:1996.

The GBIC includes the following certifications:

- UL Recognized Component (USA)
- CSA Certified Component (Canada)
- TUV Certified Component (European Union)
- CB Certificate (Worldwide)

The following figure shows the Class 1 information label that appears on the metal cover of the GBIC housing.

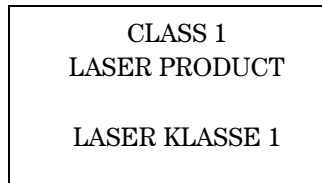

B. Product Information

Each communications port consists of a transmitter and receiver optical subassembly. The transmitter subassembly contains internally a semiconductor laser diode in the wavelength range of 780 to 1300 nanometers. In the event of a break anywhere in the fibre path, the GBIC control system prevents laser emissions from exceeding Class 1 levels.

Class 1 laser products are not considered hazardous.

WARNING **There are no user maintenance or service operations or adjustments to be performed on any GBIC model.**

C. Usage Restrictions

Failure to comply with these usage restrictions may result in incorrect operation of the system and points of access may emit laser radiation above the Class 1 limits established by the IEC and U.S. DHHS.

D. Laser Safety (Finland) LASERTURVALLISUUS

LASERTURVALLISUUS

LUOKAN 1 LASERLAITE

KLASS 1 LASER APPARAT

Fibre Channel 1063 MBaud Optical Link -kortille on asennettu optista tiedonsiirtoa varten laserlähetin, joka lähettää signaalit siihen kytketyn optisen kuidun kautta.

Normaalissa toimintatilassa lähetin on käyttäjälle turvallinen luokan 1 laserlaite, eikä käyttäjä voi altistua sen lähettämälle säteilylle. Optisen lähetinmoduulin turvallisuusluokka on määritetty standardin EN 60825 (1991) mukaisesti.

Optisessa lähetinmoduulissa ei ole huollettavia kohteita eikä sen tehtaalla tehtyjä säätöjä tule muuttaa. Lähetinmoduuli on myös suunniteltu siten, että turvallisuusluokan 1 säteilyrajat eivät ylity, vaikka lähetinmoduuliin kytketty optinen kuitu rikkoutuu tai kytketään irti lähettimen toimiessa.

Lähetinmoduulin turvallisen toiminnan varmistamiseksi on noudatettava tarkoin sen asentamisesta ja toiseen vastaanottavaan laitteistoon kytkemisestä annettuja ohjeita.

Tiedot optisessa lähetinmoduulissa käytettävien laserdiodien säteilyominaisuuksista:

Aallonpituus

(SW) 780 - 850 nm

(LW) 1300 nm

Declaration of Conformity

DECLARATION OF CONFORMITY

according to ISO/IEC Guide 22 and EN 45014

Manufacturer's Name: Hewlett-Packard Company
Enterprise Storage Solutions Division

Manufacturer's Address: 8000 Foothills Blvd.
Roseville, CA 95747 USA

declares, that the product

Product Name: Fibre Channel High Availability Storage System 1010D

Model Number(s): A5236A (with or without suffixes)

Product Options: All

conforms to the following Product Specifications:

Safety: IEC 950:1991 + A1, A2, A3, A4 / EN 60950:1992 + A1, A2, A3, A4
GB 4943-1995

IEC 825-1:1993 / EN 60825-1:1994 + A11, Class 1

EMC: CISPR 22:1993 / EN 55022:1994 - Class A¹

GB 9254-1988

EN 50082-1:1992

IEC 801-2:1991 / prEN 55024-2:1992, 4 kV CD, 8 kV AD

IEC 801-3:1984 / prEN 55024-3:1991, 3 V/m

IEC 801-4:1988 / prEN 55024-4:1993, 0.5 kV Signal Lines
1 kV Power Lines

IEC 1000-3-2:1995 / EN 61000-3-2:1995, Class A, Harmonics

IEC 1000-3-3:1994 / EN 61000-3-3:1995, Flicker

Supplementary Information:

The product herewith complies with the requirements of the Low Voltage Directive 73/23/EEC and the EMC Directive 89/336/EEC and carries the CE marking accordingly.

- 1) The Product was tested in a typical configuration with a Hewlett-Packard 9000 K-Class Computer system.

Roseville, September 4, 1998

Frank L. Sindelar, ESSD Quality Mgr.

European Contact: Your local Hewlett-Packard Sales and Service Office or Hewlett-Packard GmbH,
Department HQ-TRE, Herrenberger Straße 130, D-71034 Böblingen (FAX: + 49-7031-14-3143)

A

- AC power 148
- acoustics, product 149
- Acrobat Reader
 - World Wide Web site 77
- annotating devices
 - using SAM 78
 - using STM 79

B

- backplane/mezzanine
 - installing 137
 - removing 137

C

- cables
 - See fiber optic cables or power cables
- Cautions
 - chassis 67
 - damage from ESD 113, 115
 - damage to internal switch 133
 - disks 66
 - door 57
 - Enclosure ID 76, 122
 - HP-UX procedures 106
 - LCC pins 61
 - operating with empty slot 105, 113, 120, 124, 126
 - permanent disk damage 115
 - permanent LCC damage 120, 122
 - power supply handles 56
 - removing
 - disk 114
 - top cover 134
 - turning off disk system 131

- turning off disks sytem 133
- turning off the disk system 136
- turning on the disk system 69
- configuration
 - annotating devices 78
 - setting up Hardware Event Monitor 77
 - topologies 29
 - updating firmware 80
- configurations
 - disaster recovery 32
 - no hub 31
 - redundant hubs on redundant servers 30
- cover
 - installing 133
 - removing 133

D

- DC power 148
- dimensions, product 147
- disk
 - description of 22
 - ESD bag 115
 - installing 66, 115
 - LEDs 117
 - removing 106, 113
 - troubleshooting 100
- disk system
 - description 16–34
 - installing 130
 - mounting 56
 - removing 128
 - status indicators 19
- door
 - installing 131
 - removing 131

E

EIA Unit 46, 50
EMC compliance 150
Enclosure ID 62, 73
 illustration 123
 settings 75, 98
environment, product 148
ESD strap
 order number 42
event messages, contents of 86
event notification 77, 85–87
exchange part numbers 145
Expert Tool 111

F

fan
 description of 26
 installing 124
 LED 124
 removing 124
 troubleshooting 100, 102
FC-AL ID 75
fcmsutil 97
fiber optic cable
 installing 63
 troubleshooting 101
Fibre Channel link
 troubleshooting 97
filler
 installing 66
 removing 113
firmware
 obtaining latest release 80
 troubleshooting 103
 updating 80

G

GBIC
 description of 25
 installing 61, 118
 order number 42
 removing 118

Rx Ready LED 19, 118
troubleshooting 100
Tx Fail LED 19

H

Hardware Event Monitor 77, 84, 85
Hardware Event Monitoring for HP-UX 21
hardware requirements 146
high availability
 features 20

I

inrush current 36
installing
 backplane/mezzanine 137
 cover 133
 disk 66, 115
 disk system 130
 door 131
 fan 124
 fiber optic cable 63
 filler 67
 GBIC 61, 118
 LCC 61, 120
 PDU/PDRU 39
 power cable 63
 power supply 126
 rails in legacy HP rack 45
 rails in System/E rack 48
 tools required 42
 verifying operation 69
IOSCAN
 example 72
 hardware path 74
 viewing a disk system 72

L

laser safety 153
LCC
 description of 24
 Enclosure ID 62, 75
 enclosure services 85
 enclosure services, description of 21

-
- ESD bag 122
 - Fault LED 122
 - installing 61, 120
 - order number 42
 - removing 120
 - shown in IOSCAN 72
 - troubleshooting 100
- LEDs 19
- disk 19, 117
 - fan 19, 124
 - functions 89
 - LCC Fault 19, 122
 - power supply 19, 127
 - Rx Ready 19, 118
 - status 88–90
 - status indicators 84
 - system 19
 - Tx Fail 19
- loop ID 74
- M**
- mirrored volume 106
 - model numbers 142
- O**
- online status information 91
 - order number
 - ESD strap 42
 - GBIC 42
 - LCC 42
 - PDU/PDRU 144
 - Quick Install poster 42
 - rack filler panel 42
 - rail kit 42
 - upgrade products 143
 - User Guide 42
- P**
- part numbers 145
 - PDU/PDRU
 - definition 34
 - installing 39
 - order numbers 144
 - recommendations, number & type 38
 - troubleshooting 99
 - power cable
 - installing 63
 - troubleshooting 99
 - power supply
 - description of 27
 - installing 126
 - LED 127
 - removing 126
 - troubleshooting 100, 102
 - power up the disk system 69
 - product
 - AC power 148
 - acoustics 149
 - DC power 148
 - dimensions 147
 - EMC compliance 150
 - environment 148
 - exchange part numbers 145
 - models 142
 - options 142
 - replacement part numbers 145
 - safety certifications 150
 - weight 147
- Q**
- Quick Install poster
 - order number 42
- R**
- rack filler panel
 - order number 42
 - rail installation
 - legacy rack 45
 - System/E rack 48
 - rail kit
 - order number 42
 - removing
 - backplane/mezzanine 137
 - cover 133
 - disk 106, 113
-

- disk system 128
- door 131
- fan 124
- filler 113
- GBIC 118
- LCC 120
- power supply 126
- replaceable parts, description of 22–25
- replacement part numbers 145

S

- safety certifications 150
- SAM
 - annotating devices 78
 - replacing disks 106
 - status indications 96
- site preparation 36
 - electrical 36
 - PDU/PDRU 37
- software requirements 146
- status
 - using SAM 91
 - using STM 94
- status information, online 91
- steady state current 36
- STM
 - annotating devices 79
 - identifying slots 111
 - Information Log contents 94
 - status indications 96

T

- topologies 29–33
- troubleshooting
 - event notification 85
 - fiber optic cables 97
 - Fibre Channel link 97
 - isolating causes 99
 - online status information 91
 - overview 84
 - status LEDs 88
 - table 99

- turning on the disk system 69

U

- upgrade products
 - order numbers 143
- User Guide
 - order number 42

W

- Warnings
 - backplane 115
 - disk 115
 - disk system weight 56
 - ESD 22
 - lifting disk system 129
- weight, product 147

Reader Comment Sheet

Hewlett-Packard SureStore E Disk System FC10 User and Service Guide

We welcome your evaluation of this manual. Your comments and suggestions will help us improve our publications. Remove this page and mail or FAX it to 916-785-2299. Use and attach additional pages if necessary.

	Agree				Disagree		N/A
The manual is well organized.	<input type="radio"/>	<input type="radio"/>	<input type="radio"/>	<input type="radio"/>	<input type="radio"/>	<input type="radio"/>	<input type="radio"/>
The information is technically accurate.	<input type="radio"/>	<input type="radio"/>	<input type="radio"/>	<input type="radio"/>	<input type="radio"/>	<input type="radio"/>	<input type="radio"/>
Information is easy to find.	<input type="radio"/>	<input type="radio"/>	<input type="radio"/>	<input type="radio"/>	<input type="radio"/>	<input type="radio"/>	<input type="radio"/>
Step-by-step procedures are easy to perform.	<input type="radio"/>	<input type="radio"/>	<input type="radio"/>	<input type="radio"/>	<input type="radio"/>	<input type="radio"/>	<input type="radio"/>
There are enough examples and pictures.	<input type="radio"/>	<input type="radio"/>	<input type="radio"/>	<input type="radio"/>	<input type="radio"/>	<input type="radio"/>	<input type="radio"/>
The examples and pictures are useful.	<input type="radio"/>	<input type="radio"/>	<input type="radio"/>	<input type="radio"/>	<input type="radio"/>	<input type="radio"/>	<input type="radio"/>

Comments _____

Name: _____	Phone: _____
Title: _____	FAX: _____
Company: _____	E-mail: _____
Address: _____	ZIP: _____
City & State: _____	Country: _____

___ Check here if you would like a reply.

Hewlett-Packard has the right to use submitted suggestions without obligation, with all such ideas becoming the property of Hewlett-Packard.

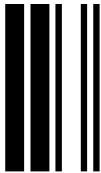

NO POSTAGE
NECESSARY
IF MAILED
IN THE
UNITED STATES

BUSINESS REPLY MAIL
FIRST CLASS MAIL PERMIT NO. 256 ROSEVILLE, CA
POSTAGE WILL BE PAID BY ADDRESSEE

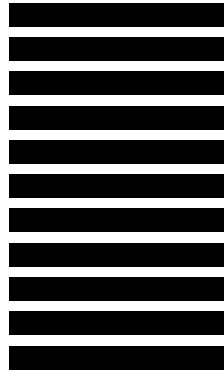

Attention: Information Engineering (MS 5668)

**Hewlett-Packard Company
Enterprise Storage Business Unit
8000 Foothills Blvd.
Roseville, CA 95747-5668**



Fold Here



Manual Part Num
A5236-90001 E1299

Copyright © 1999
Hewlett-Packard Company
Printed in U.S. A.



A5236-96020