

Contents

About This Guide

How this Guide is Arranged	vii
Symbols in Text.....	viii
Product Safety Information	viii
Symbols on Equipment	viii
Laser Precautions	ix
Rack Stability	ix
Getting Help	x

Chapter 1

Introduction

Digital Linear Tape Libraries	1-1
Features.....	1-2

Chapter 2

Installation

Choosing a Location.....	2-1
Materials Needed.....	2-1
Installation Overview	2-2
Step 1, Assembling and Mounting Slide Rails.....	2-2
Step 2, Installing the Tape Library into the Rack	2-8
Step 3, Attaching the Cable Management Arm	2-11
Step 4, Connecting and Routing Cables.....	2-13
Installing a Second DLT Tape Drive (Optional).....	2-14



Chapter 3 **Tape Cartridges**

Selecting Tape Cartridges	3-1
Write-Protecting Tape Cartridges	3-2
Tape Cartridge Bar Code Labels	3-3
Labeling Bulk Load Magazines.....	3-4
Loading and Unloading Tape Cartridges	3-4
Maintaining Tape Cartridges.....	3-8
Tape Cleaning.....	3-9

Chapter 4 **Operation**

Front Panel Controls.....	4-1
Display Panel.....	4-2
Using the Keypad	4-4
Operational Modes	4-4
Accessing Administration Menus	4-7
Entering the Current Password.....	4-7
Setting a New Password	4-8
Saving a New Password	4-9
INFO Menu	4-9
Test Menu.....	4-13
Configuration Menu	4-18
Cleaning the Library Tape Drives	4-20
Setting SCSI IDs	4-22
Using On-line Drive Replacement	4-25

Chapter 5 **Troubleshooting**



Appendix A

Regulatory Compliance Notices

Federal Communications Commission Notice.....	A-1
Class A Equipment.....	A-1
Class B Equipment.....	A-2
Modifications.....	A-2
Cables.....	A-2
Canadian Notice (Avis Canadien).....	A-3
Class A Equipment.....	A-3
Class B Equipment.....	A-3
European Union Notice.....	A-4
Japanese Notice.....	A-4
Laser Devices.....	A-5
Laser Safety Warnings.....	A-5
Compliance with CDRH Regulations.....	A-5
Compliance with International Regulations.....	A-5
Laser Product Label.....	A-6
Laser Information.....	A-6

Appendix B

Electrostatic Discharge

Preventing Electrostatic Damage.....	B-1
Grounding Methods.....	B-2

Appendix C

Specifications

Appendix D

Power Cord Set Requirements

General Requirements.....	D-1
Country-Specific Requirements.....	D-2

.....

▪
vi

Appendix E
Getting Help

Compaq Web Site..... E-1
Telephone Numbers..... E-1

Index

About This Guide

This User Guide is designed to be used as step-by-step instructions for installation and as a reference for operation, troubleshooting, and future upgrades of the Compaq 15 Cartridge DLT Library. For information on tape back-up software, refer to its documentation.

How this Guide is Arranged

This manual is divided into the following six chapters.

Chapter 1 - *Overview*

This section provides general information and an introduction to the features of the tape library.

Chapter 2 - *Installation*

This section provides step-by-step instructions for the installation options and installation of the tape library into a Compaq 19" rack.

Chapter 3 - *DLT Tapes*

This chapter explains the types of DLT Cartridges supported by the tape library and how to use them.

Chapter 4 - *Operation*

This section contains information about the configuration and day-to-day operation of the tape library.

Chapter 5 - *Troubleshooting*

This section contains routine maintenance procedures and high-level troubleshooting information.

NOTE: This User Guide contains configuration and upgrade information that will prove valuable in the future. If you are installing the tape library but will not be the end user, please pass this guide on to the person who will be responsible for the unit when you have completed the installation.

Symbols in Text

These symbols may be found in the text of this guide. They have the following meanings.



WARNING: Indicates that failure to follow directions in the warning could result in bodily harm or loss of life.



CAUTION: Indicates that failure to follow directions could result in damage to equipment or loss of information.

IMPORTANT: Presents clarifying information or specific instructions.

NOTE: Presents commentary, sidelights, or interesting points of information.

Product Safety Information

Symbols on Equipment

These icons may be located on equipment in areas where hazardous conditions may exist.



Any surface or area of the equipment marked with these symbols indicates the presence of electrical shock hazards. Enclosed area contains no operator serviceable parts.

WARNING: To avoid risk of injury from electrical shock hazards, do not open this enclosure.



Any surface or area of the equipment marked with these symbols indicates the presence of a hot surface or hot component. If this surface is contacted, the potential for injury exists.

WARNING: To avoid risk of injury from a hot component, allow the surface to cool before touching.

Laser Precautions



WARNING: To reduce the risk of injury from laser radiation or damage to the equipment, observe the following precautions:

- Allow only Compaq Authorized Service Technicians to repair the equipment.
 - Do not open any panels, operate controls, make adjustments, or perform procedures to a laser device other than those specified herein.
 - Do not stare into laser beam when panels are open.
-

Rack Stability



WARNING: To reduce the risk of personal injury or damage to the equipment, be sure that the leveling jacks extend to the floor and that the full weight of the rack rests on the floor. Each rack should be level and stable. Install stabilizing feet on a single rack or join multiple racks together before starting work.



WARNING: To reduce the risk of personal injury or damage to equipment, heed all warnings and cautions throughout the installation instructions. Because the rack allows you to stack computer components on a vertical rather than a horizontal plane, you must take precautions to provide for rack stability and safety.



WARNING: To reduce the risk of personal injury or damage to the equipment, always install the heaviest items in the bottom of the rack and load the rack from the bottom up. This makes the rack bottom-heavy and helps prevent the rack from becoming unstable. See “Configuration Rules” in the Rack Planning and Installation Guide for the rules that govern the vertical placement of rack-mounted components. This information is also included in the Rack Builder diskette.



WARNING: To reduce the risk of personal injury, always ensure that the rack is adequately stabilized before extending a component outside the rack. Extend only one component at a time. The rack may become unstable if more than one component is extended for any reason.

Getting Help

Although this guide has been designed to provide all the information that you should normally need, you may find that you require additional help. Appendix E contains telephone numbers and web access information to assist you in getting additional help.

If you:

- encounter a problem during installation
- require help performing the procedures in this Guide
- need to order a part from Compaq

Refer to Appendix E for the telephone number of your nearest Compaq Reseller or Authorized Service Provider. The Compaq web site is a good place to get the latest operating system drivers and other information that could help you get the most from your new Compaq product.

Chapter 1

Introduction

The Compaq DLT Library has a native capacity of 225 GB, containing fifteen Type III XT tape cartridges. When data compression (2:1) is used, some library capacities can be increased to 450 GB.

Digital Linear Tape Libraries

The Compaq tape library is ideal for unattended backup, archival storage, and hierarchical storage (files are migrated from higher-cost hard disks to lower-cost digital linear tapes). There are software packages available that support these products on Compaq computer systems. A software driver for digital linear tape libraries is required to store information on the library.

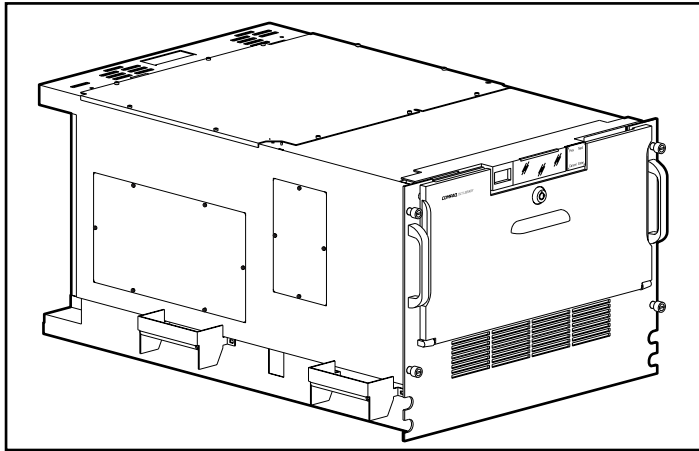

Figure 1-1. DLT Library

Features

The following features apply to the Tape Library

**Table 1-1
Features**

Feature	Description
Form Factor	Rack-mountable in 19-inch rack
Maximum Number of Drives	2
Interface	Fast-SCSI-2
SCSI ID Select	Automatic
Options	Second DLT Drive Kit Cartridges Cleaning Tapes Bar Code Labels for the tape cartridges
Status Indicators	Front panel activity light Display panel
Warranty	Three-years parts and labor On-site where available

Chapter 2

Installation

This section provides step-by-step instructions for the installation of the tape library and tape library options.

Choosing a Location

Refer to your *Rack Planning and Installation Guide* for guidelines and site requirements in selecting a site for your rack. The tape library is one of the heaviest rack components and should be located lower in the rack than many other components. For help in locating the tape library in the 19-inch rack, refer to the Rack Builder software installation utility available from your local Compaq Reseller or Authorized Service Provider.

In addition installation requires that the rack have installed anti tip feet (42 U racks) or the anti tip plate (22 U racks) prior to installing the library.

Materials Needed

To install the tape library you will need:

- Compaq tape library rack mounting template
- Rack mounting hardware kit
- Any options to be installed
- AC power cord
- External SCSI cable (supplied)

Installation Overview

Installing the tape library into the rack requires the following steps:

Step 1, Assembling and mounting the slide rails to the rack.

Step 2, Attaching the tape library to the slide rails.

Step 3, Attaching the cable management arm.

Step 4, Connecting and routing external cables.



WARNING: To reduce the risk of electric shock or damage to the equipment:

- Do not disable the power cord grounding plug. The grounding plug is an important safety feature.
 - Plug the DLT Tape Library into a grounded (earthed) electrical outlet that is easily accessible at all times.
 - Disconnect power from the library by unplugging the power cord from either the electrical outlet or the library.
-

Step 1, Assembling and Mounting Slide Rails

To assemble and mount the slide rails you will need to:

- Mark the rack position for the tape library with the template.
 - Install cage nuts in the rack.
 - Attach the inner slide rail to the mounting bracket.
 - Install the mounting bracket on the rack.
-

Marking the Rack

A rack mounting template is provided to mark the rack for cage nut and mounting bracket positions. Starting at the bottom of the rack, or at the top of a previously mounted component:

1. Place the template in the desired location with the two push tabs. Make sure that you match the hole pattern printed on the template with the actual holes on the racks vertical rails.

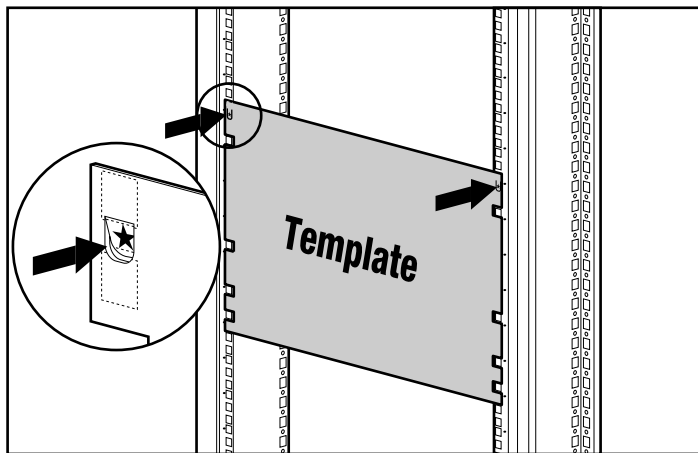

Figure 2-1. Measuring with the template

2. Use a pencil to mark locations indicated on the template for cage nuts and mounting brackets.
3. After marking the front of the rack, flip the template over and repeat the procedure on the back rails of the rack. Also mark where the top of the template is on the rack. This will help you to align the next component.

Inserting Cage Nuts

Use the fitting tool to insert cage nuts on the **inside** of the rails at the marked locations.

NOTE: The cage nuts and fitting tool are included in the hardware kit supplied with the rack.

2-4 Installation

1. On the inside of the rail, hook one of the lips of the cage nut through the square rail hole.
2. Insert the tip of the fitting tool through the other side of the hole and hook the opposite lip of the cage nut.

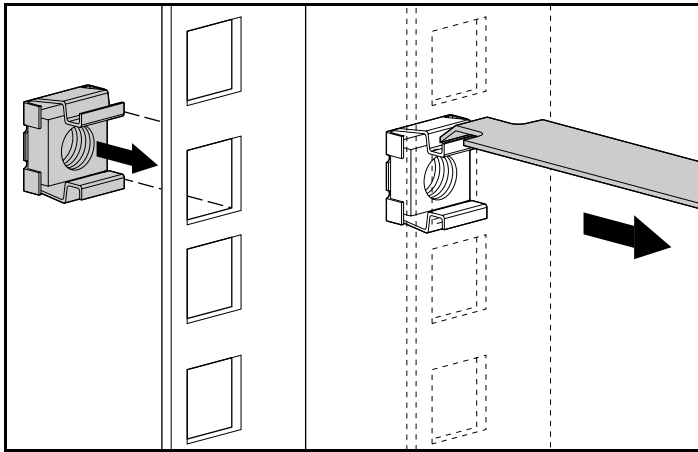

Figure 2-2. Inserting cage nuts

3. Using the fitting tool as a lever, pry the cage nut into position.
4. Repeat for each cage nut.

Attaching the Slide Rail to the Mounting Bracket

The mounting bracket and slide rail form an assembly that attaches to the rack. To attach the slide rail to the mounting bracket:

1. Lay a slide rail inside a mounting bracket making sure that the front of the slide rail is at the front of the mounting bracket. To identify the front of the mounting bracket and the bracket rail:
 - ❑ The front of the mounting bracket has screw threads on its flange.
 - ❑ The front of the slide rail allows the inner slide to move forward.

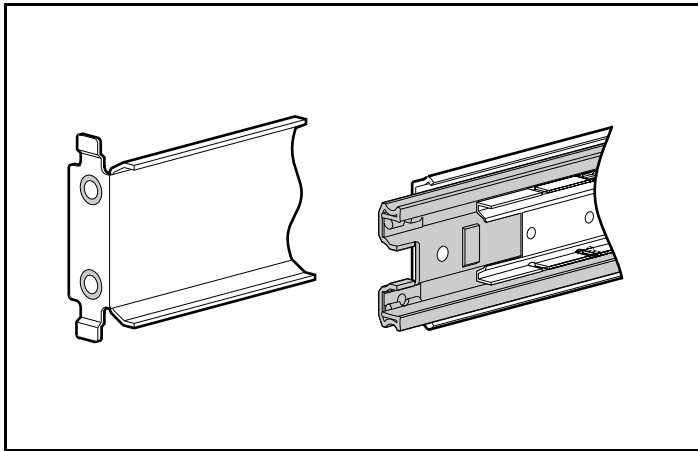

Figure 2-3. Identifying the front of the Slide Rail and the Mounting Bracket.

2. Align the front screw holes in the slide rail and the mounting bracket.
3. Fasten the slide rail to the mounting bracket using four 8-32 x 1/4-inch slotted screws (supplied). Adjust the inner slide to access the screw holes through the slotted opening in the inner slide as shown in the following figure.

2-6 Installation

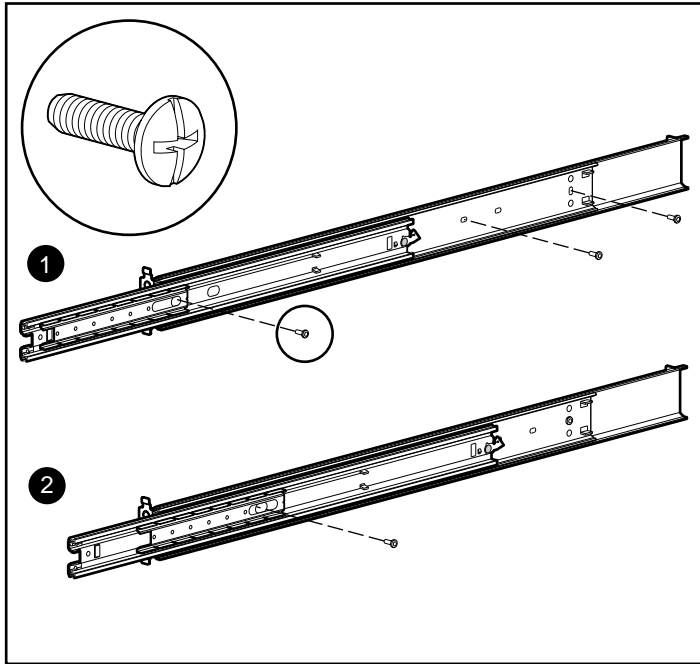

Figure 2-4. Attaching the bracket rail to the mounting bracket

4. Repeat steps 1 through 3 for the other slide rail and mounting bracket.

Attaching the Mounting Bracket Assembly to the Rack



CAUTION: Make sure that the mounting brackets are aligned correctly or the unit will malfunction and cause premature failures.

To attach the mounting brackets to the rack:

1. Place a mounting bracket in position according to the pencil marks made earlier.

2. Attach the front of the bracket first, using two M6 x 1.0-12L Phillips screws in the bracket. **Do not use washers.**

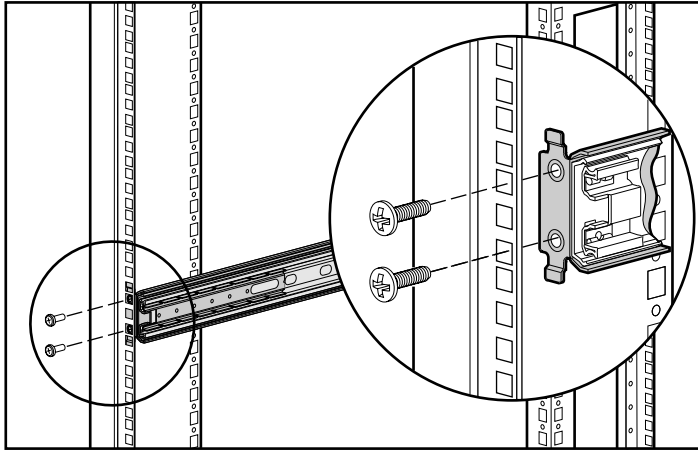

Figure 2-5. Attaching mounting bracket assembly to the front of the rack

3. Secure the back of the mounting bracket with two M6 x 1.0-12L Phillips screws and the cage nut.

IMPORTANT: Make sure that the mounting bracket is level from front to back.

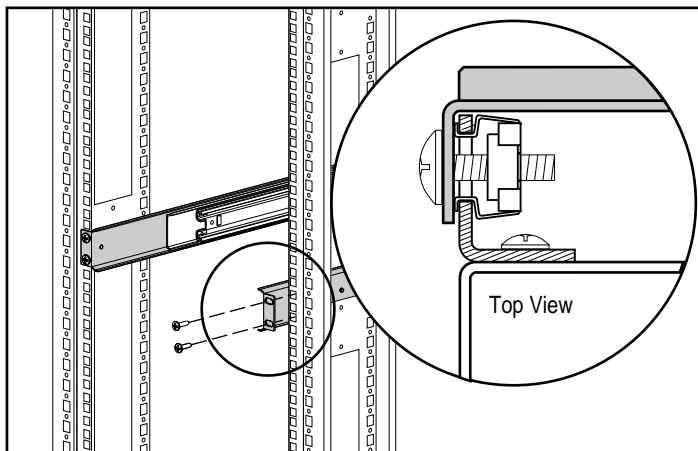

Figure 2-6. Cage nut and back of mounting bracket assembly installed

Step 2, Installing the Tape Library into the Rack



WARNING: To reduce the risk of personal injury or damage to the equipment, a minimum of two people **MUST** lift the Tape Library into the rack. If the unit is to be loaded above chest level, additional personnel and or equipment must assist.

1. Extend the slide rails forward until they lock in position.
2. Lift the library onto the slides using the side handles. Make sure that the handles sit securely on the slides and that the library mounting holes are aligned with the slides screw holes.

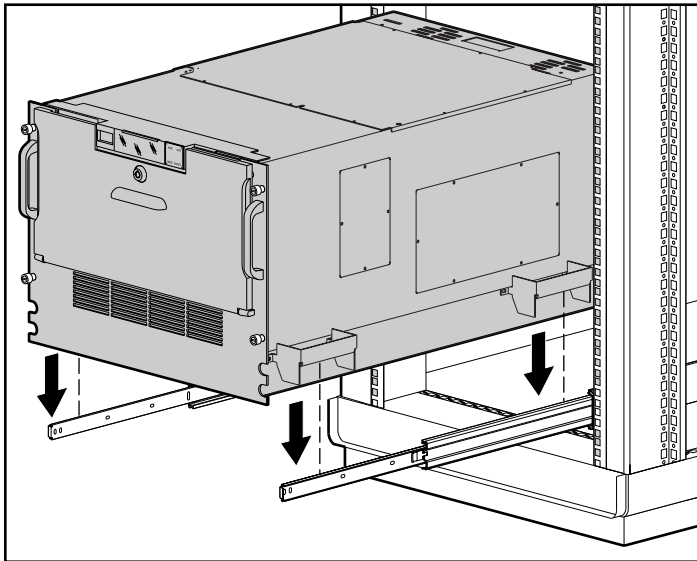

Figure 2-7. Lowering the tape library on the slide rails

3. Attach the tape library to each slide with three torx mounting screws.

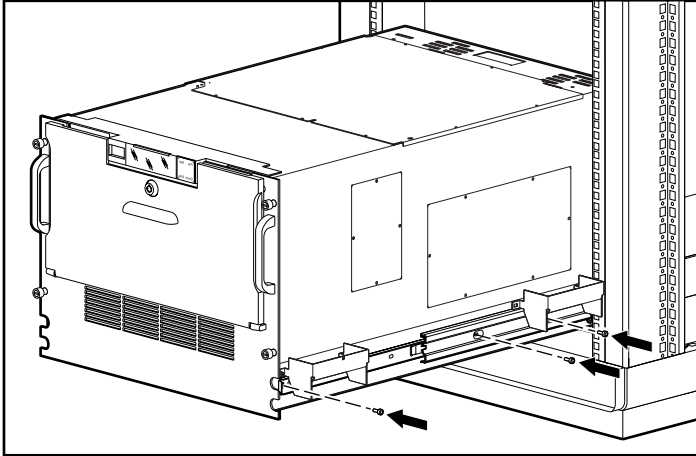

Figure 2-8. Attaching the tape library to slide rails

4. Remove the tape libraries installation handles. Be sure to keep the handles and mounting screws in case the unit needs to be moved in the future.

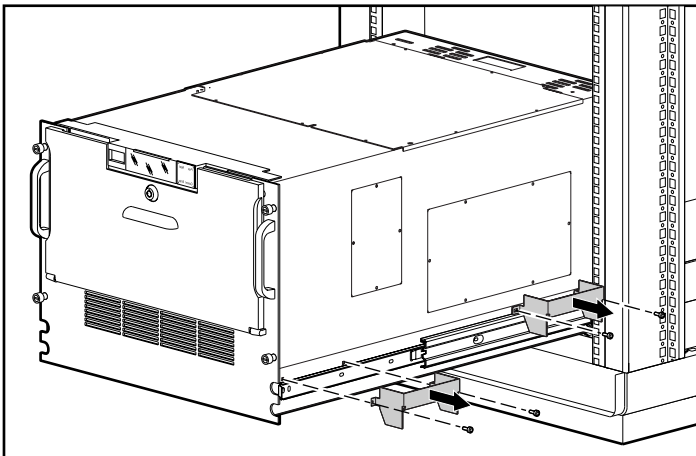

Figure 2-9. Removing the installation handles



WARNING: To reduce the risk of personal injury, be careful when pressing the component rail release latches and sliding the component into the rack. The slide rails could pinch your fingertips.

3. Depress the component rail release latches and slide the tape library into the rack.

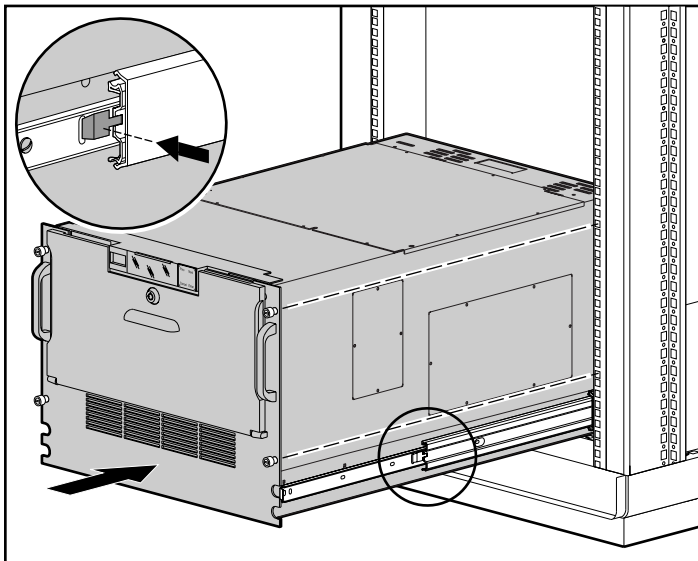

Figure 2-10. Loading the rack server

IMPORTANT: The first time you slide the component into the rack, you may have to apply some pressure. After the first time, the ball bearings in the slide will move easily.

4. Secure the tape library to the rack using the front panels thumb screws.

Step 3, Attaching the Cable Management Arm

All cables to and from the server are tied to the cable management arm to allow the cables to swing out of the way when accessing the tape library.

To attach the cable management arm:

1. Slide the server into the rack.
2. Attach the cable management arm to the cable management arm bracket using two 10-32 K-Lock nuts.

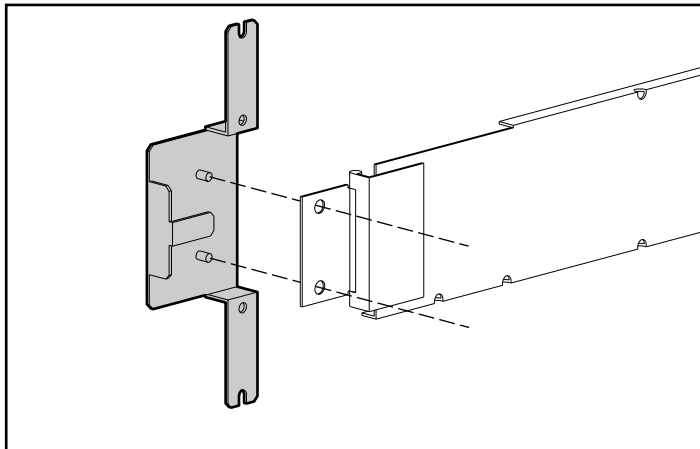

Figure 2-11. Attaching the cable management arm to its bracket

3. Attach the cable management arm bracket to the tape library using the 6-32 x Pan Head screws.

2-12 Installation

4. Align the other end of the Cable Management Arm on the *outside* of the rear rack frame. Align the bar nut on the *inside* of the rack with the fingers extending through the rack perforations. Attach using the 10-32 x5/8 washer face Phillips-Head screws.

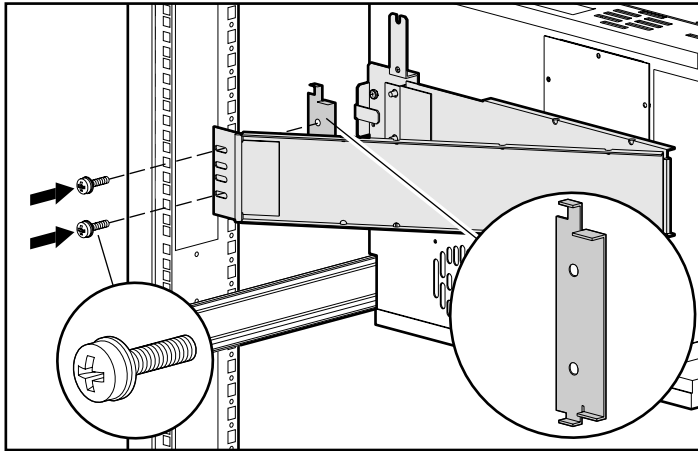

Figure 2-12. Attaching the cable management arm to the rack

Step 4, Connecting and Routing Cables

The library connects to the host computer with high-density SCSI interface cable. To cable your tape library:

1. Connect the Fast SCSI and power cables to the tape library.

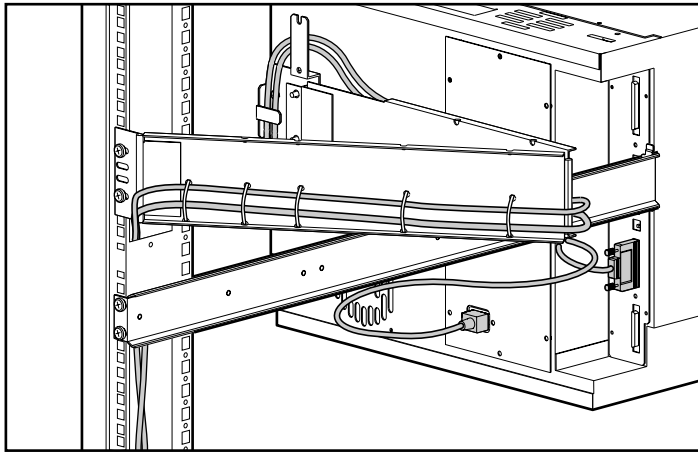

Figure 2-13. Power and Signal Cables

2. Route the signal and power cables as flat as possible, and tie them to the cable management arm as shown in the previous figure.
3. Extend the bundled cables down the rack's cable channel.

Your tape library can now be brought on-line in accordance with your network and tape operating system procedures.

Installing a Second DLT Tape Drive (Optional)

The DLT Tape Library requires special library-reading DLT drives. Standard internal and external DLT drives are not compatible with the tape library. If you are installing a second DLT Tape drive use a Compaq option part only.



WARNING: The DLT Tape Library contains laser radiation and mechanical equipment that are considered hazardous. To reduce the risk of personal injury:

- Allow only Compaq Authorized Service Technicians to repair the equipment.
- Do not open any panels, operate controls, make adjustments, or perform procedures to The Tape Library other than those specified herein.
- Do not stare in to laser beam when panels are open.

Repairs should be performed only by individuals who are qualified in servicing computer equipment and trained to deal with products containing hazards.

To install a second tape drive:

1. Turn the system off and unplug the power cord from the back of the unit.
-

2. Remove the front panel.

IMPORTANT: When removing the front panel do not let the panel drop after the retaining screws are removed. There is a small cable that is attached to the back of the panel that must be disconnected.

a. Remove the ten torx screws shown.

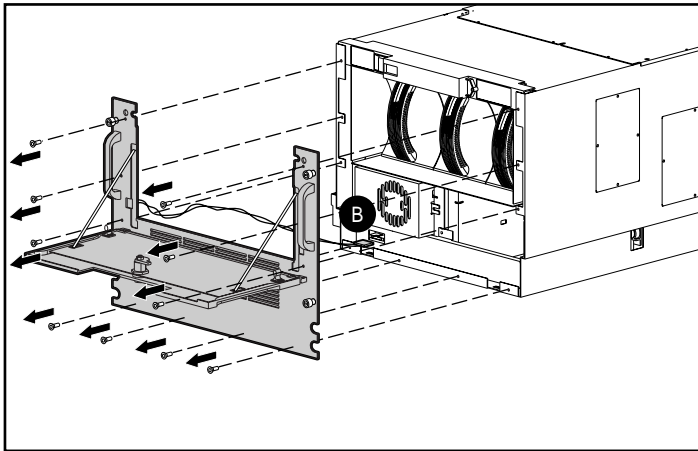

Figure 2-14. Removing the front panel

b. Disconnect the open door sensor signal cable.

3. Remove the cable access panel.

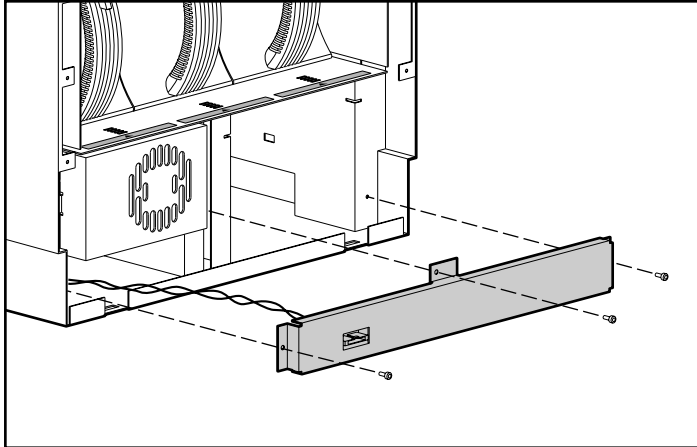

Figure 2-15. Removing cable access panel

4. Remove the fan from the tape drive being installed.

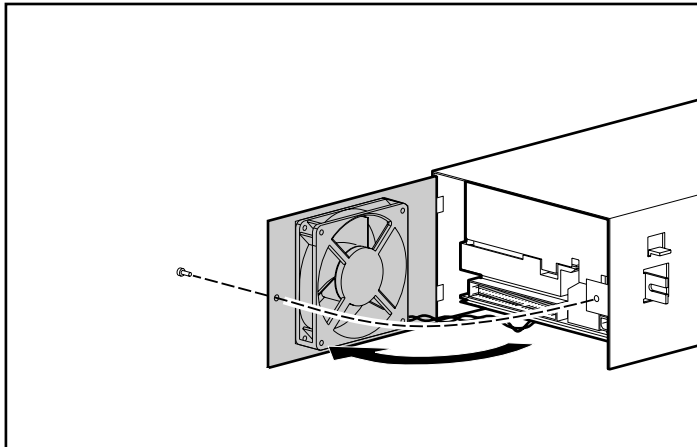

Figure 2-16. Removing the tape drive fan

- Slide the tape drive into the tape library and secure with the two torx screws.

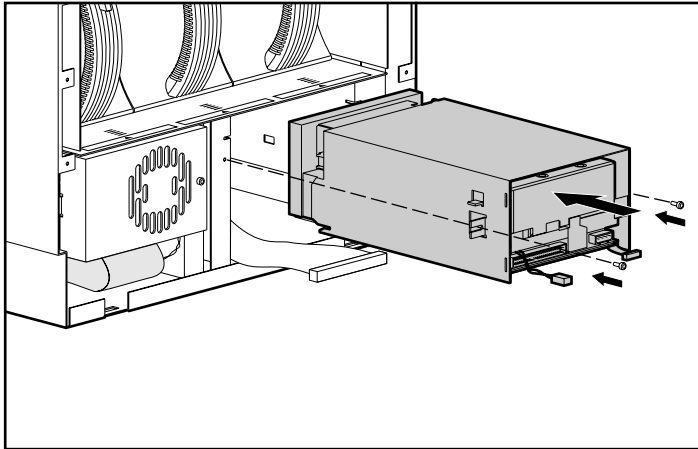

Figure 2-17. Installing the tape Drive

- Connect the following cables as shown:

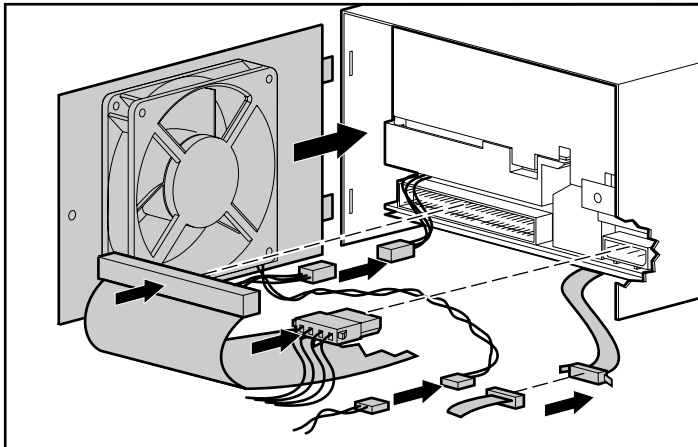

Figure 2-18. Connecting the cables



▪

2-18 *Installation*

7. Replace tape drive fan.
8. Replace cable access panel.
9. Replace the front panel.

Installation of the second tape drive is now complete. The SCSI ID for this drive will automatically be set to 4.

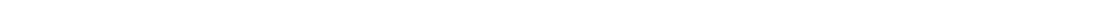

Chapter 3

Tape Cartridges

The tape cartridges that you use in the tape drive are an integral part of the storage process. This section provides information on:

- Selecting tape cartridges
- Write-protecting tape cartridges
- Tape cartridge bar code labels
- Labeling bulk load magazines
- Loading and unloading tape cartridges
- Maintaining tape cartridges

Selecting Tape Cartridges

The two types of digital linear tape cartridges available to which the tape drive can read and write are:

- DLT tape III Data Cartridge
- DLT tape III XT Data Cartridge

The tape densities available for each cartridge type are shown in Table 3-1:

Table 3-1
Native Tape Densities

Cartridge Type	Available Densities
DLT type III Data Cartridge	10.0 GB
DLT type III XT Data Cartridge	15.0 GB

Write-Protecting Tape Cartridges

The use of the write protect switch ensures data safety for files that have been previously written to the tape and prevents any additional files from being written to the tape.

To change the write-protect setting:

- Move the write protect switch to the left to prevent any data from being written to the cartridge. The orange indicator on the cartridge can be seen when the write protect switch is in the “ON” position.
- Move the write protect switch to the right to allow data to be written to the cartridge. The orange indicator on the cartridge cannot be seen when the write protect switch is in the “OFF” position.

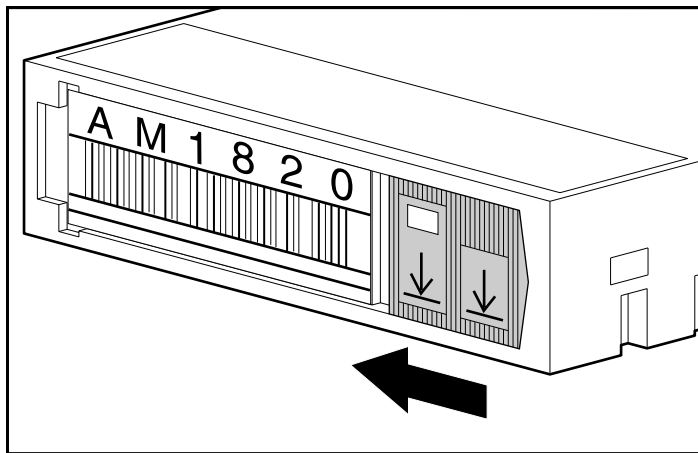

Figure 3-1. Write protecting tape cartridges

NOTE: Data can be read from the cartridge with the write protect switch in either position.

Tape Cartridge Bar Code Labels

Tape cartridge bar code labels are provided for use with host software packages that support bar codes. The bar codes allow the tape software to track information such as:

- date of format or initialization
- cartridge owner (group/department, etc.)
- storage purpose (backup, old version of operating system, etc.)

IMPORTANT: If bar code labels are not used, be sure to set "Bar code On/Off" configuration to "OFF".

NOTE: You will want to create your own method of tracking this information if your host software does not support bar codes.

To label a tape with a bar code:

1. Remove a bar code label from its perforated sheet.
2. Slide the label with the numbers up into the slot on the front face of the cartridge.

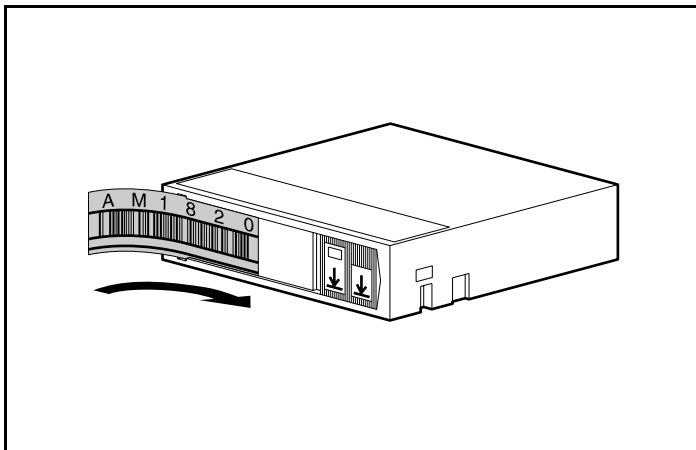

Figure 3-2. Inserting a bar code label

Labeling Bulk Load Magazines

Bulk load magazines can be labeled in a manner similar to tape cartridges if needed. To label bulk load magazines:

1. Remove the adhesive backing from the label pouch.
2. Apply the pouch to the front of the magazine.
3. Slide the label into the pouch

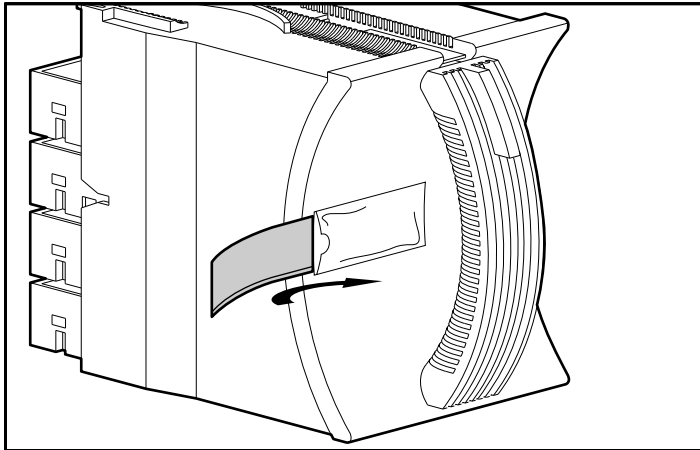

Figure 3-3. Labeling bulk load magazines

Loading and Unloading Tape Cartridges

Tapes are bulk loaded into magazines which are then inserted into the library through the front access door. The tape library is designed to hold from one to three 5-slot magazines.

IMPORTANT: Some software packages require that you insert and remove cartridges using the software. If you are using a software package to manage files in the library, check the software documentation before proceeding with these steps.

NOTE: Be sure to label all cartridges before inserting them into the magazines.

The tape cartridges with or without bar codes and storage slot locations will be stored into library memory when the door is closed and the INVENTORY CHECK test is automatically run.

To prevent cartridges from sliding out of the bulk load magazines when inserting them into the library do not use excessive force when inserting the magazines into the library. This can cause the magazine "latching" mechanisms to fail.

During normal library operation, the cartridge release button on top of the magazine is pushed down by a mechanism inside the library that unlocks the cartridges. This allows the cartridges to be inserted and removed from the storage slots as needed. When the control panel RELEASE DOOR option is enabled, the button on top of the magazine is released, which locks the cartridges into the magazine slots.



CAUTION: If a power failure occurs, the cartridge release button mechanism is defeated and cartridges can slide out of their storage slots if a magazine is inserted or removed from the library. This could cause damage to the library if a cartridge is allowed to slide out of the magazine and into the library. After a power outage always reset the tape libraries power to re-engage the tape locking mechanism.

To load tapes into the library, do the following:

1. Verify that the drive numbers and status indicators are displayed. If they are not displayed, press **CANCEL** until they display. Verify that all drives in the library are empty.



is displayed after the drive number if the drive is empty



is displayed after the drive number if the drive is full

▪

▪

3-6 Tape Cartridges

2. Press **NEXT** or **PREV** until **RELEASE DOOR** appears in the display window.
3. Press **ENTER**. **DOOR RELEASED** displays.

NOTE: The tape drive(s) must be empty before the access door can be released. If the drive(s) are not empty, **EMPTY DRIVES NO** displays. Press **NEXT** or **PREV** until **RELEASE DOOR** displays and then press **ENTER**.

Some security configurations may prevent the access door from being released. If a security option is enabled, **SECURITY ENABLED** displays after the **RELEASE DOOR** option is chosen. In some situations it may be necessary to override a security option and open the access door. To open the access door when a security option prevents the door from being released, use the **DOOR OVERRIDE** option under the **ADMIN*** menu.

4. Remove the tape magazines from the tape library.
5. Insert up to five tape cartridges into a magazine so that the tape brand name printed on the top of the cartridge is facing up and the tape label is facing out towards you. The tapes should click into place.

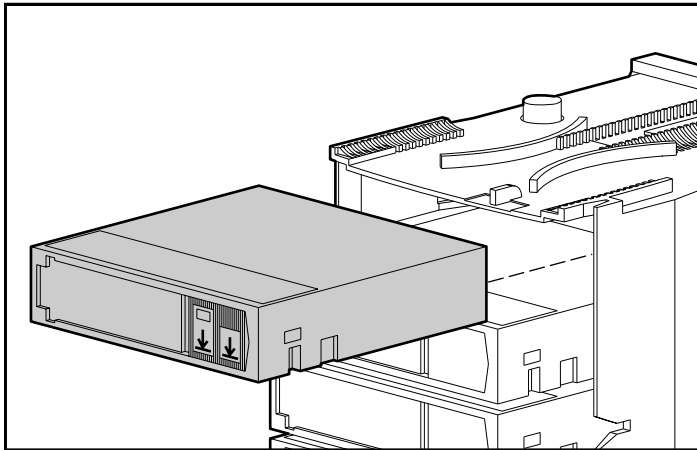

Figure 3-4. Loading tape cartridges into the magazine

6. Insert the magazine into the library as shown.

IMPORTANT: The magazine must click into place.

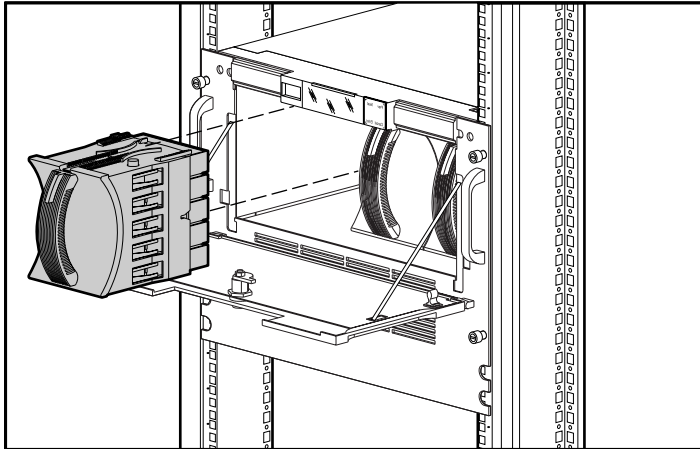

Figure 3-5. Inserting Magazines Through the Front Access Door

7. Shut and lock the access door using the key lock. Make sure the door is shut completely or the library will fail the INVENTORY CHECK test, which automatically runs when the access door is closed.

NOTE: The library "Inventory Check" test runs when the access door is closed. The "Inventory Check" test inventories the tape bar code labels and storage slot locations, and stores them in library memory. This process takes approximately one minute.

Maintaining Tape Cartridges

Follow these guidelines to maintain your tape cartridges:

- Do not expose the cartridge to magnetic fields.
 - Do not leave the cartridge in the tape drive when library power is off.
 - Do not expose the cartridge to extreme temperatures or extreme humidity. Acceptable operating temperatures range from 10 to 40°C (50 to 104°F). Acceptable storage temperatures range from 16 to 32°C (60 to 90°F). Acceptable operating or storage humidity ranges from 20 to 80%.
 - Do not expose the cartridge to moisture or direct sunlight.
 - Do not drop the cartridges or carry them in a manner that could submit the cartridges to any unnecessary physical shock.
 - Do not open the cartridge lid, exposing the tape to possible contamination and/or physical damage.
 - Do not touch the tape surface.
 - Do not take the cartridge apart.
 - Store the cartridge in a clean, safe place in its protective plastic container when it is not in use.
 - If dust is built up on tapes remove it from the *outside* of the cartridge using a damp cloth.
 - The cartridge should be stored vertically, not flat.
 - Store cartridges intended for archiving data in their plastic containers and in environmental conditions of 18 to 28° C (64 to 82° F) and 40% to 60% relative humidity.
 - Use labels like those included in the accessories kit or that meet the specifications listed in Appendix C only.
 - Do not use graphite pencils, water soluble felt pens, or other debris-producing writing instruments to label cartridges.
-

- Never erase a label; replace it.

Tape Cleaning

The tape inside the tape cartridge cannot be cleaned; however, there are issues relating to tape cartridge use that affect drive cleaning.

NOTE: The tape drives do not require scheduled cleaning maintenance. Excessive use of the cleaning cartridge can cause unnecessary wear on the drive head.

IMPORTANT: After 20 cleaning cycles, the cleaning cartridge must be replaced.

The following table lists special circumstances that can cause a drive cleaning message to be displayed when a tape cartridge may be at fault.

Table 3-2
Drive Cleaning Issues Relating to Tape Cartridges

If this happens ...	It means ...	And you need to ...
A brand new tape cartridge is used and a drive cleaning message is received.	Debris from the tape manufacturing process was deposited on the drive head.	Clean the drive If the message is displayed again within a short amount of time, return the cartridge for warranty replacement.
An older, frequently-used tape cartridge is loaded and a drive cleaning message is received.	Dust from frequent tape loads and unloads has most likely built up on the tape cartridge and was deposited on the drive head.	Clean the <i>outside</i> of the tape cartridge using a damp cloth. Clean the tape drive.

▪

▪

3-10 *Tape Cartridges*

An older, frequently-used tape causes a cleaning message to be displayed for the second time.

The tape is most likely damaged. (Damaged cartridges can cause unnecessary use of the cleaning cartridge.)

1. Verify the tape is readable by clearing the error message. (Select the "ON-LINE REPAIR" option from the control panel, and turn off power to the drive containing the tape, and then turn the drive power on again.

2. Try reading the tape again.

- If the tape can be read, back up data from the damaged cartridge to another tape cartridge and discard the damaged one.
 - If the tape cannot be read, call your service representative.
-

Chapter 4

Operation

This chapter describes configuration options and operational procedures for the tape library.

NOTE: Information presented in this chapter pertains only to the tape library hardware. For questions regarding software configuration, refer to the documentation that came with your tape backup software.

Front Panel Controls

The tape library user controls are accessible from the front panel so there is no need to open the tape library door to make configuration changes or to monitor tape drives. The illustration below and corresponding table provide a description of the front panel controls and status indicators.

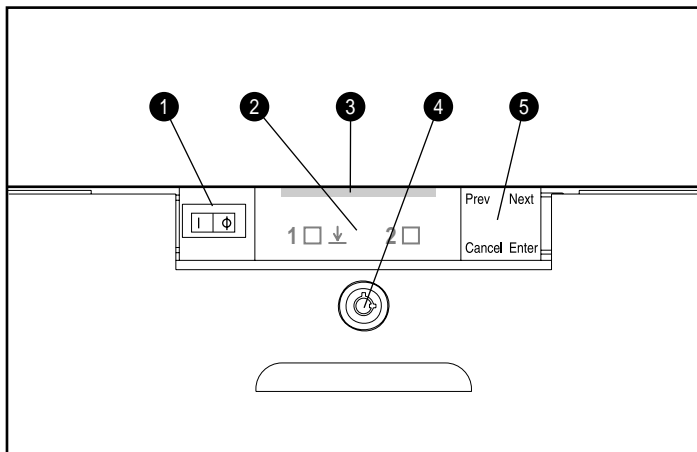

Figure 4-1. DLT Tape Library Controls

Table 4-1
Controls and Status Indicators











Item	Name	Description
①	Power Switch	Switches power to the unit on and off.
②	Display panel	Displays information about the current operation, drive status, and configuration menus.
③	Activity Light	Displays tape library current status: <ul style="list-style-type: none">• Steady Green - power is on• Flashing Green - a tape cartridge is being accessed• Amber - fault indicator
④	Key Lock	Used to lock/unlock the front panel for access to tape magazines.
⑤	Keypad	Used to access the tape library configuration and function menus. To perform the following operations, press: "CANCEL" cancels the current operation or choice. "PREV" scrolls the display choice backward by one. When held continuously the choices scroll quickly. "NEXT" scrolls the display choice forward by one. When held continuously the choices scroll quickly. "ENTER" selects the displayed option.

Display Panel

The display panel provides current drive status during normal operation and the configuration menus and options when in the administration mode. The administration menus and configuration options are described later in this chapter.

During normal operation, the display indicates the current status of each tape drive using symbols which are explained in the following table. An example of how the symbols are displayed follows the table.

Table 4-2
Drive Status Symbols

Symbol	Type	Purpose
	Status	The drive needs to be cleaned.
	Status	The tape in the drive is write-protected.
	Status	The drive is empty.
	Status	The drive is full.
	Status	(Blank) The drive is off-line or not included.
	Activity	The drive is being cleaned.
	Activity	Information is being written to the tape.
	Activity	Information is being read from the tape.
	Activity	The tape is being searched backward.
	Activity	The tape is being searched forward.

In the following example, Drive 1 has a cartridge inserted and data is being written to the tape, and Drive 2 needs to be cleaned.

Example:

1   2 

Using the Keypad

The keypad allows the user to select the operational mode and access configuration menus and options. The keypad has four selections:

- **CANCEL** - cancels the current operation or choice.
- **PREV** - scrolls the display choice backward by one. When held continuously the choices scroll quickly.
- **NEXT** - scrolls the display choice forward by one. When held continuously the choices scroll quickly.
- **ENTER** - selects the displayed option.

Each time you press the **NEXT** or **PREV** choice, a task option appears. (If you see an "*" as part of the message, it indicates there is a menu beneath that option, which you can access by pressing **ENTER** on the keypad. To move to a different menu press **NEXT** or **PREV**.)

Operational Modes

The tape library has three operational modes:

- **Ready**
- **Off Line - Release Door**
- **Administration**

Ready

In the Ready mode, the library starts after a brief self-test and inventory check when the unit is powered on. During normal operation there is little if any user intervention required. The status display indicates the status of each drive as described earlier in this chapter.

Off Line - Release Door

Takes the library off-line and releases the door for accessing the tape magazines. Before the door is released you must first select whether the drives should be emptied or not. When power is applied the door will not open unless it is released.

Administration Mode

The Administration mode contains seven submenus that allow you to perform various configuration, maintenance and test functions. Refer to the following table for information on each administration menu.

Table 4-3
Administration SubMenus

Menu	Purpose
INFO *	Retrieve performance information
TEST *	Run internal library tests
CONFIG *	Customize the tape library
CLEAN DRIVES *	Select drive to clean.
DOOR OVERRIDE	Unlock the front access door (if necessary) under certain circumstances (such as the drives being full or a security option being set or, prevent the "RELEASE DOOR" option from unlocking the door.
SCSI ID's *	Set the SCSI addresses for the library controller and the library drives
ON-LINE REPAIR *	De-activate a drive for replacement

* Indicates there are multiple selections available for that operation.

When a menu selection is flashing, press **ENTER** to select the option, or press **PREV** or **NEXT** to display other available options.

4-6 Operation

The following figure shows the library options and menus available through the control panel. Press **PREV** or **NEXT** to scroll through the list. To perform the displayed operation, press **ENTER**.

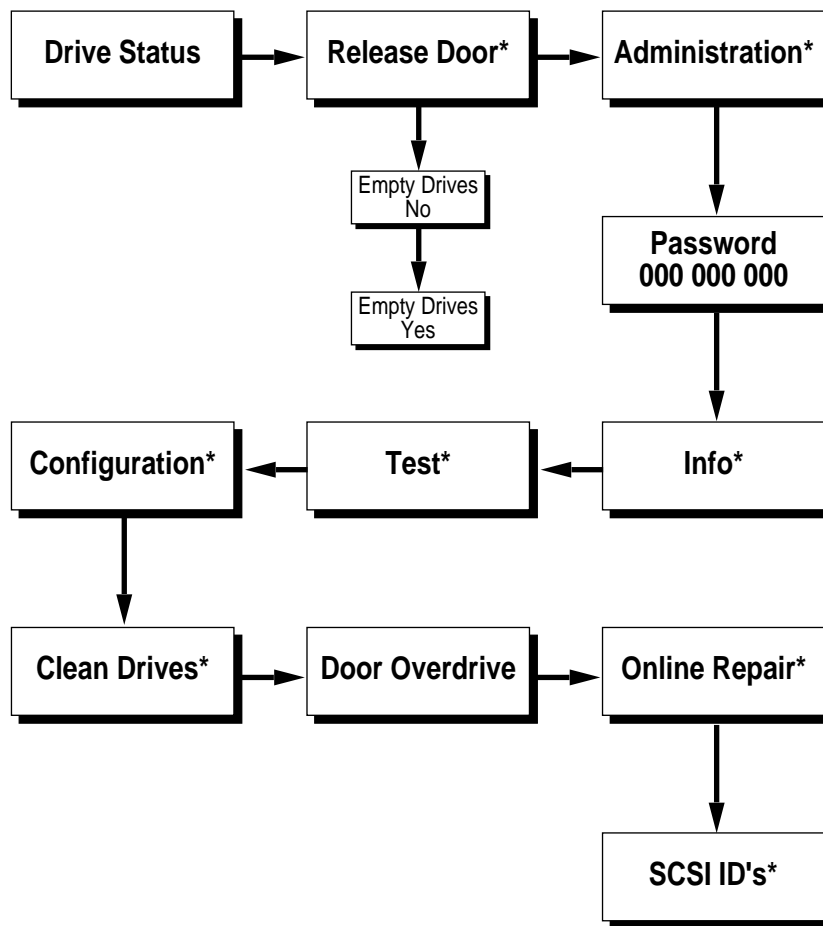

Figure 4-2. Tape Library Display Menu tree

Accessing Administration Menus

The Administration mode contains seven sub-menus that allow you to perform various configuration, maintenance, and test functions. Before you can access the administration menus you must first enter a password. The default password is 000-000-000. You may want to change this code to prevent access by unauthorized personnel.



WARNING: To reduce the risk of personal injury or damage to the equipment, the password should only be given to persons having appropriate technical training and experience necessary to be aware of the hazards to which they are exposed. The password allows access to some functions that allow access to potential mechanical and laser radiation hazards.

Entering the Current Password

Follow these steps to enter the current password:

1. Verify that the library is in the ready mode and that the drive numbers and their status indicators are displayed. If they are not displayed, press **CANCEL** until they display.
2. Press **NEXT** until ADMIN* appears in the display window.
3. Press **ENTER**. PSWD 000 000 0000 displays and the first set of zeros is flashing.
4. Press **ENTER** to accept this number if no password has been set, or press **NEXT** or **PREV** until the first three numbers you have set for the password are displayed. Press **ENTER**. The middle set of zeros will now begin flashing.
5. Repeat step 4. for the second and third set of numbers. Press **ENTER**.

You can now access options under the Administration menu by pressing **NEXT** until the desired menu is displayed, and then pressing **ENTER**.

Setting a New Password

IMPORTANT: Don't forget your password. Only a service representative can reset the password if you forget it.

To change the password:

1. Verify that the library is in the ready mode and that the drive numbers and their status indicators are displayed. If they are not displayed, press **CANCEL** until they display.
 2. Press **NEXT** until ADMIN* appears in the display window.
 3. Press **ENTER**. PSWD 000 000 0000 displays and the first set of zeros is flashing.
 4. Press **ENTER** to accept this number if no password has been set, or press **NEXT** or **PREV** until the first three numbers you have set for the password is displayed. Press **ENTER**. The middle set of zeros will now begin flashing.
 5. Repeat step 4 for the second and third set of numbers. Press **ENTER**.
 6. Press **NEXT** until CONFIG* displays, and then press **ENTER**.
 7. Press **NEXT** until NEW PASSWORD displays and then press **ENTER**.
 8. NEW 000 000 000 displays and the first set of zeros is flashing. Press **NEXT** or **PREV** until the new number you wish to assign to the first part of the password is displayed and then press **ENTER**. The second set of zeros will begin flashing.
 9. Repeat step 8 for the second and third set of numbers. Press **ENTER**.
 10. PASSWORD CHANGED displays. Press **CANCEL** three times to return to the drive status indicators (Ready State).
-

Saving a New Password

The new password can be saved to flash ROM by power cycling the library. This allows the password to be recovered if the library is powered off for more than ten days.



CAUTION: Do not switch off power to the library until you are sure the SCSI bus is inactive. Removing power from a SCSI peripheral when the bus is active can result in data loss and/or indeterminate bus states. (Check your host system manuals for information about checking the SCSI bus status.) If your computer is connected to a LAN, be sure to check with your system administrator before shutting off power to the library.

INFO Menu

You can display information about the operations of the library from the INFO menu. This information is called a log.

The following procedures assume that you have accessed the Administration menu and entered the administration password.

To access an information log:

1. Press **NEXT** until INFO * is displayed and then press **ENTER**. (An "*" indicates that there are more choices beneath the displayed choice.)
2. Press **NEXT** until the name of the log you wish to access displays and then press **ENTER**.
3. Press **CANCEL** to return to the drive status (Ready mode).

Descriptions of the available information logs are on the following pages.

**Table 4-4
Information Logs**

Log	Description
REVISION	Displays the library's firmware version number.
LIB ODOMETERS *	Press ENTER to select the odometer logs described in the next few rows.
HOURS	Displays the number of operation hours (time during which the power was on).
MOVES	Displays the total number of moves and move attempts by the cartridge transport mechanism.
XLATES	Displays the total number of cartridge transport mechanism horizontal moves.
DRIVE LOADS *	Press ENTER to select the logs described in the next few rows.
DRIVE 1	Displays the number of tape cartridge loads for drive number 1.
DRIVE 2	Displays the number of tape cartridge loads for drive number 2. (model dependent)
HARD ERRORS *	Log of unrecoverable errors, commands that did not successfully complete. Returns either "NO HARD ENTRIES" or "ENTRY #". (There may be multiple hard error numbers.) Press ENTER to view the log for the currently displayed error, or press NEXT to select the next error. (The log entries are described in the rows following "RECOVERY ERROR" in this table.)

continued

Information Logs *continued*

Log	Description
SOFT ERRORS *	Log of recovered errors, commands successfully completed. Returns either "NO SOFT ENTRIES" or "ENTRY #". (There may be multiple soft error numbers.) Press ENTER to view the log for the currently displayed error, or press NEXT to select the next error. (The log entries are described in the rows following "RECOVERY ERROR" in this table.)
RECOVERY ERRORS *	Log of errors during most recent move. Returns either "NO RECOV ENTRIES" or the number of recovery errors. Press ENTER to view the log for the currently displayed error, or press NEXT to select the next error. (The log entries are described in the following rows.)
*HARDWARE ERR#	This error number indicates the cause of the failure.
*FRU 1 #	The spare part most likely to be at fault.
*FRU 2 #	The spare part second most likely to be at fault.
*FRU 3 #	The spare part third most likely to be at fault.
MOTION <name>	<name> indicates one of the following types of movements taking place in the library at the time of the failure: <ul style="list-style-type: none"> • EXCHANGE • MOVE • POSITION • INIT ELEM • REZERO • DIAGNOSTIC • RESTORE

continued

Information Logs *continued*

Log	Description
SOURCE #	The element number to which the source refers. (This information is valid for MOVE, EXCHANGE, and POSITION movements only.)
DESTINATION 1 #	The element to which the first destination refers. (This information is valid for MOVE and EXCHANGE movements only.)
DESTINATION 2 #	The element to which the second destination refers. (This information is valid for the EXCHANGE movement only.)
ODOMETER #	The move number in which the error occurred.
*MICROMOVE 1 #	The first library micro-move for the original move command issued prior to the failure.
*MICROMOVE 2 #	The second library micro-move for the original move command issued prior to the failure.
*MICROMOVE 3 #	The third library micro-move for the original move command issued prior to the failure.
*MICROMOVE 4 #	The fourth library micro-move for the original move command issued prior to the failure.
*MICROMOVE 5 #	The fifth library micro-move for the original move command issued prior to the failure.
*MICROMOVE 6 #	The last library micro-move for the original move command issued prior to the failure.
*MICROMOVE ER #	The actual micro-move error that occurred.

* **ENTER** can be pressed when an error number is displayed to receive further information.

Test Menu

The library can run self-diagnostic tests.



CAUTION: Some diagnostic tests, which are noted in the following table, can corrupt your file system if a test is not properly completed. (Tape cartridges can be placed in unexpected locations.) These types of test should be run only by authorized service personnel.

The following procedures assume that you have accessed the Administration menu and have entered the administration password.

To run these tests do the following:

1. Press **NEXT** until TEST* appears in the display window and then press **ENTER**.
2. Press **NEXT** until the name of the test you wish to run displays and then press **ENTER**.
NUM LOOPS # will be displayed.
3. Press **NEXT** until the number of cycles you wish the test to go through displays, and then press **ENTER** to start the test.

NOTE: You may press **CANCEL** at any time to abort a test. TEST CANCEL WAIT displays while the current test loop completes.

Descriptions of the available internal tests are on the following pages. (Tests are listed alphabetically according to function.)

**Table 4-5
Internal Tests**

Test Name	Description	Result
EXERCISE MECH	Runs the VERTICAL TEST, TRANSLATE TEST, MAGAZINE IO, and DRIVE IO tests. Each test is run one time per test loop.	Pass /Fail
EXCHANGE DEMO	Used by service personnel only. Do not run this test if the library contains tape cartridges with file system data on them. This test moves randomly-chosen cartridges to random storage slot locations. This test fails if there are no cartridges in the library or if all storage slots are full. For best results, the library should contain as many cartridges as there are drives, plus two additional cartridges. The transport must be empty.	Pass /Fail
IO DRIVE	If the drives are empty, a tape cartridge is moved from a randomly-chosen full slot to a randomly-chosen drive. If the drives are full, a tape cartridge is moved from a randomly-chosen drive to a randomly-chosen storage slot. It then moves the cartridge back to its original location. This test displays if there are no cartridges in the library or if all storage slots are full. The drives and transport must be empty.	Pass /Fail
IO MAGAZINE	Moves a tape cartridge from a randomly-chosen full slot to a randomly-chosen empty slot. It then moves the cartridge back to its original storage slot. This test displays if there are no cartridges in the library or if all storage slots are full. The drives and transport must be empty.	Pass /Fail
INVENTORY CHECK	Functions the same as the SCSI Initialize Element Status command. This test physically scans the entire unit to determine which storage slots contain tape cartridges and if the drives contain cartridges. NOTE: This test appears as "ISTAT TEST" in all control panel error messages.	Pass /Fail

continued

Internal Tests *continued*

Test Name	Description	Result
TEST TRANSLATE	Translates from side to side. No tape cartridges are required.	Pass /Fail
TEST VERTICAL	Moves the transport mechanism up and down the full length of the transport rail. No tape cartridges are required.	Pass /Fail
WELLNESS TEST	Checks out the general capability of the library. Requires one loaded tape cartridge; drives and transport must be empty. Runs INIT MECHANICS and EXERCISE MECH. Each test is run one time per test loop.	Pass /Fail
FIND PLUNGE HOME	Runs mechanism recalibration, determines the reference points in the picker travel path, and tests the picker. This test assumes that the mechanics and servo system are functional. No tape cartridges are required.	Pass /Fail
FIND VERT HOME	Recalibrates the vertical position and verifies that the vertical path is clear. No tape cartridges are required.	Pass /Fail
FIND XLATE HOME	Calibrates the translate position. No tape cartridges are required.	Pass /Fail
INIT MECHANIC S	Runs the FIND PLUNGE HOME, FIND VERTICAL HOME, FIND XLATE HOME tests. Each test is run one time per test loop.	Pass /Fail
EMPTY DRIVES	Used by service personnel only. Do not run this test if the library contains tape cartridges with actual file system data on them. Moves cartridges out of the drive mechanisms and returns them to their home storage slot locations if the locations are known, otherwise the cartridges are placed into the first available empty storage slot.	Pass /Fail

continued

Internal Tests *continued*

Test Name	Description	Result
EMPTY PICKER	Used by service personnel only. Do not run this test if the library contains tape cartridge with actual file system data on them. Moves a tape cartridge from the cartridge transport mechanism to its home storage slot location if that location is known, otherwise the cartridge is placed into the first available empty storage slot.	Pass /Fail
FILL PICKER	Used by service personnel only. Do not run this test if the library contains tape cartridges with actual file system data on them.	Pass /Fail
REWIND MEDIA	Used by service personnel only. Do not run this test if the library contains tape cartridges with actual file system data on them. Rewinds the tape in the drive(s) and opens the solenoid in the drive handle, which allows the tape to be removed from the drive.	Pass /Fail
CLEAR SOFT LOG	Sets the soft error log to zero.	Pass /Fail
CLEAR HARD LOG	Sets the hard error log to zero.	Pass /Fail
PLUNGE FULL SPD	Allows the cartridge transport mechanics to run at full speed. This setting should always be used under normal library operation.	Pass /Fail
PLUNGE 1/2 SPD	Used by service personnel only. Allows the cartridge transport mechanics to run at half speed.	Pass /Fail
SENSOR TRANSLATE	Tests the horizontal path that the cartridge transport mechanism follows when moving from one stack of tape cartridges to another. Displays ON or OFF. If OFF displays, the sensor is blocked. (This display is automatically updated if the sensor status changes.) Requires the use of one tape cartridge.	Pass /Fail

continued

Internal Tests *continued*

Test Name	Description	Result
SENSORS CADDY	The display shows C1 1 C2 1 C3 1. Each "1" indicates that the caddy is in place. If a "0" is displayed, the caddy has not been inserted into the library. (This display is automatically updated if the sensor status changes.)	Pass /Fail
SENSORS STARWARS	The display shows 0-----0 Each "0" indicates one of the paths that the cartridge transport mechanism follows in front of each stack of tape cartridges. If the path is clear, a "0" is displayed; if the path is blocked (because of a cartridge that is not inserted fully into its storage slot for example), an "*" will be displayed. (This display is automatically updated if the sensor status changes.)	Pass /Fail
VERTICAL ENCODER	Moves the cartridge transport mechanism down, moves it back up a short distance, and then moves it back down. The last time the transport mechanism is moved down, the number of encoder counts is verified. Returns PASS/FAIL. No tape cartridges are required.	Pass /Fail

To access an information log:

1. Press **NEXT** until INFO * is displayed and then press **ENTER**. (An "*" indicates that there are more choices beneath the displayed choice.)
2. Press **NEXT** until the name of the log you wish to access displays and then press **ENTER**.
3. Press **CANCEL** to return to the drive status (Ready mode).

Descriptions of the available information logs are on the following pages.

Configuration Menu

You can set certain options to customize the way the library operates. These options are called configurations.

The following procedures assume that you have accessed the Administration menu and entered the administration password.

To change a configuration:

1. Press **NEXT** or **PREV** until the name of the configuration you wish to set displays and then press **ENTER**. If the configuration has multiple settings, the current setting will flash. Otherwise, the configuration option will be set and a confirmation message will display. (Configuration options are described on the following pages.)
2. If the current configuration setting is flashing, press **NEXT** or **PREV** until the desired setting is displayed, and then press **ENTER**. **OPTION SAVED** displays.
3. Press **CANCEL** to return to the drive status ("ready" state). You may need to press several times.

Descriptions of the available configurations are in the following table.

Table 4-6
Configuration Choices

Name	Description	Default
RECOVERY ON/OFF	Toggles between ON and OFF. If the configuration is set to ON, the library attempts to recover from errors; if the configuration is set to OFF the library immediately stops moving if an error condition occurs. The default configuration is RECOVERY ON, and recovery should remain ON under normal conditions. This feature should only be changed by service personnel	ON

RESTORE DEFAULTS	Sets all library configurations back to their default settings.	N/A
---------------------	---	-----

continued

Configuration Choices *continued*

Name	Description	Default
CLEAR ODOMETERS	Used by service personnel only. Sets all library odometers back to zero.	N/A
STARWARS ON/OFF	Used by service personnel only; it should be set to ON during normal operation. Toggles between ON and OFF. If the configuration is set to ON, the library runs with the vertical sensors enabled; if the configuration is set to OFF, the library runs with the vertical sensors disabled.	ON
NEW PASSWORD	Allows you to change the numerical password required to access the options under the ADMIN* menu on the library control panel. These options include configurations, tests, and information logs. To change the security code, see "Setting a New Administration Menu Password" in this chapter.	N/A
SCSI LOG ON/OFF	Used by service personnel only; should be set to OFF during normal operation. Toggles between ON and OFF. Tracks internal SCSI states and saves the information to a log.	OFF
SECURE ON/OFF	Toggles between ON and OFF. If the configuration is set to ON, tape magazines cannot be loaded or removed. If the configuration is set to OFF, the library operates in its default state, which allows cartridges to be loaded and removed.	OFF
POWER SECURE ON/OFF	Toggles between ON and OFF. When set to ON, the SECURE ON/OFF configuration setting is retained in the event of a power outage. If this configuration is set to OFF, the library returns to its default setting of POWER SECURE OFF when power is returned after being shut off.	OFF

continued

Configuration Choices *continued*

Name	Description	Default
REP RECOVERED ON/OFF	Toggles between ON and OFF. When set to ON, recovered errors are reported; when set to OFF, the recovered errors are not reported.	ON
CONF40 ON/OFF	Used by service personnel only. Do not attempt to use this configuration--to do so may result in a service call.	OFF
BARCODE ON/OFF	Toggles between ON and OFF. When set to ON the barcodes and slot locations are stored into library memory when the front access door is closed and the "Inventory Check" test is automatically run. When set to OFF, the barcodes are not recorded when the "Inventory Check" test is run. Set to OFF when bar codes are not used.	ON

Cleaning the Library Tape Drives

The drive mechanisms do not require scheduled cleanings and should only be cleaned if a status indicator is displayed after the drive number.

If a cleaning cartridge is not stored inside the tape library, it must be inserted into a library storage slot prior to doing these steps.

If the cleaning cartridge needs to be replaced, REPLACE CLEANING is displayed.

Your host software may manage tape drive cleaning.

NOTE: Cleaning the digital linear tape drives requires the use of a special digital linear tape cleaning cartridge. (Typically, cleaning cartridges are light yellow and data cartridges are black, brown, or white.)

Cleaning takes approximately five minutes per drive.

The following procedures assume that you have accessed the Administration menu and entered the administration password.

To clean one or more of the tape drives:

1. Press **NEXT** until CLEAN DRIVES* displays, and then press **ENTER**.
 - a. If the library power has been turned off or the access door has been opened since you last selected a cleaning cartridge location , SELCLEAN CART * displays. Press **ENTER**.
 - b. If the library power has not been turned off or the access door has not been opened since you last selected a cleaning cartridge location, CLEAN CART LOC # displays. (# is flashing and is the cleaning cartridge storage slot location last selected.) If the storage slot location is correct, press **ENTER** and go to Step 2; or if you wish to select a different storage slot location, press **NEXT** or **PREV** until the correct storage slot location is displayed, press **ENTER**, and go to Step 2.
2. ##### SLOT # displays (where "#####" is a barcode number or is blank if bar codes are not being used, and "#" is a storage slot location and is flashing). Press **ENTER** to select the displayed storage slot location or press **NEXT** or **PREV** to select a different storage slot location, and then press **ENTER**.
3. CLEAN DRIVE 1 displays and the "1" is flashing. Press **NEXT** or **PREV** until the drive number you wish to clean displays and then press **ENTER**.

If you wish to clean both drives, press **NEXT** or **PREV** until CLEAN DRIVE ALL displays and then press **ENTER**.

NOTE: If the drives are not empty, a DRIVE FULL message will be displayed, and the drives must be emptied before they can be cleaned.

If the slot location chosen in Step 2 did not contain a cleaning cartridge, NOT CLEAN CART displays briefly and then CLEAN FAIL # displays. Press **CANCEL** twice to return to the "ready" state. Check the bulk load magazines in the library to locate the cleaning cartridge. If no cleaning cartridge is present, insert one into an available slot.

CLEANING DRV # displays (# is the number of the drive being cleaned). When the drive has been cleaned, CLEANED DRV # displays briefly, and then CLEAN DRIVES # is again displayed.

NOTE: If the host system software controls drive cleaning, the drive status indicator, C, is displayed after the drive number(s) being cleaned and the activity indicator flashes until the drive(s) are clean.

4. Press **CANCEL** until the next operation you wish to perform is displayed, or until the drive status indicators (library "ready" state) are displayed.

Setting SCSI IDs

There are two options available when SCSI IDs* is chosen:

- SET ID's (allows you to assign individual SCSI IDs to each drive in the library and to the library controller.)
- VIEW ID's (allows you to see the current drive and library controller settings.)

To set an individual SCSI ID see, “Changing the Current SCSI Address Settings.”

To view the current SCSI address settings, see “Viewing the Current SCSI Address Settings.”

Table 4-7
Default SCSI Address Settings

Device	SCSI ID
LIB ID	6
DRV 1 ID	5
DRV 2 ID*	4

* may or may not be included in some models

If you are already using any of these IDs for your computer or another SCSI peripheral device, follow the instructions in "Changing the Current SCSI Address Settings" to change the controller or the drive ID.

Changing the Current SCSI Address

A SCSI address is required for the library controller and for each tape drive inside the library. To change the current SCSI address settings, do the following steps:

The following procedures assume that you have accessed the Administration menu and entered the administration password.

1. Press **NEXT** or **PREV** until the SCSI ID'S displays and press **ENTER**. SET ID'S displays.
2. Press **ENTER**. LIB ID or DRV # displays.
(LIB ID # stands for the current SCSI ID of the library controller, and DRV # ID # is the current SCSI ID setting for the displayed drive number.)

3. Press **NEXT** until the setting you wish to change is displayed, and then press **ENTER**. The # (current SCSI address setting) is flashing.
4. Press **NEXT** or **PREV** until the address you want displays and then press **ENTER**.
5. Press **NEXT** until UPDATE ID'S NOW displays, and then press **ENTER**.
6. ID'S SAVED displays briefly, and then one of the following messages displays:
 - a. If the new settings do not conflict with other SCSI IDs on the bus, SCSI ID'S* displays.
 - b. If the new settings conflict with other IDs on the SCSI bus, SET ID's displays briefly and then CONFLICT ABORTED displays. Any changes entered are lost, and you must repeat the previous steps to set a new address.
7. Press **CANCEL** three times to return to the drive status indicators ("ready" state).

NOTE: After you change an address you may have to reboot your computer for the new SCSI IDs to be recognized.

The new settings can be saved to flash ROM by power cycling the library. This allows the settings to be recovered if the library is powered off for more than ten days.



CAUTION: Do not switch off power to the library until you are sure the SCSI bus is inactive. Removing power from a SCSI peripheral when the bus is active can result in data loss and/or indeterminate bus states. (Check your host system manuals for information about checking the SCSI bus status.) If your computer is connected to a LAN, be sure to check with your system administrator before shutting off power to the library.

Viewing the Current SCSI Address Settings

To view the current SCSI address settings:

The following procedures assume that you have accessed the Administration menu and entered the administration password.

1. Press **NEXT** or **PREV** until the SCSI ID'S displays and press **ENTER**. SET ID'S displays.
2. Press **ENTER**. LIB ID or DRV # displays.
(LIB ID # stands for the current SCSI ID of the library controller, and DRV # ID # is the current SCSI ID setting for the displayed drive number.)
3. Press **NEXT** or **PREV** to scroll through the current SCSI address settings.
4. Press **CANCEL** until the next operation you wish to perform is displayed, or until the drive status indicators (library "ready" state) are displayed.

Using On-line Drive Replacement



WARNING: To reduce the risk of personal injury from electrical shock and laser radiation, this function should be used by authorized service representatives only. Use of this option will cause the library drive mechanism(s) to become inactive.

On-line drive replacement is an important feature that allows:

- an authorized service representative to replace a faulty drive while the library is active
- a user to clear a drive cleaning error when a tape that may be damaged is in the drive

Under normal conditions, this option should **only** be used by authorized service representatives. However if an older, frequently-used tape causes a drive cleaning message to be displayed more than once and you suspect the tape is damaged, the "On-line Repair" option can be used to clear the drive error message so you can attempt to recover data from the damaged tape. To use this option to clear a drive cleaning error, do the following steps:

1. With CLEAN DRV# displayed, press **CANCEL** until the drive numbers and status indicators are displayed. (# is the drive number containing the damaged tape.)
2. Press **NEXT** until ADMIN* appears in the display window and then press **ENTER**.

3. Enter Password. INFO* displays.
 4. Press **NEXT** until ON-LINE REPAIR displays, and then press **ENTER**. DRIVE POWER displays.
 5. Press **NEXT** until DRIVE STATUS displays and then press **ENTER**. DRIVE 1 ON GOOD displays.
 - ❑ If the damaged tape is in drive 1, press **ENTER**.
 - ❑ If the damaged tape is in drive 2, press **NEXT** until DRIVE 2 ON GOOD displays, and then press **ENTER**.
 6. DRIVE # ON GOOD displays, where "#" is the drive number and "ON GOOD" is flashing.
 7. Press **NEXT** until DRV # OFF FAILED displays.
 8. Press **ENTER**. CHANGED CONFIRMED displays briefly and then ON-LINE REPAIR displays.
 9. Press **ENTER**. DRIVE POWER* displays.
 10. Press **NEXT** or **PREV** until DRIVE STATUS displays, and then press **ENTER**.
 11. Press **NEXT** or **PREV** until DRIVE # OFF FAILED displays (where "#" is the number of the drive that was just taken off-line).
 12. Press **ENTER**. DRIVE # OFF FAILED displays, where "#" is the drive number and "OFF FAILED" is flashing.
 13. Press **NEXT** until DRV # ON GOOD displays.
 14. Press **ENTER**. CHANGED CONFIRMED displays briefly and then ON-LINE REPAIR* displays.
 15. Press **CANCEL** twice to return to the drive numbers and status indicators ("ready" state).
 16. Try reading the damaged tape again.
 - ❑ If the tape can be read, back up data from the damaged cartridge to another tape cartridge and discard the damaged one.
-

- ❑ If the tape cannot be read, call your service representative.

Chapter 5

Troubleshooting

This section provides information on solutions to problems that may occur in the operation of the library. The following table lists steps you should take before consulting your service representative.

For problems that may be related to your computer, refer to your computer system documentation or library application software documentation.

Table 5-1
Troubleshooting

Problem	What to do
Library will not power on.	<ul style="list-style-type: none"> • Make sure the power cord connections are tight. • Make sure the power switch is switched on. (The power switch is located on the library control panel.) • Make sure the power outlet is operating. • Replace the power cord with a known good one. • If the library still won't power on, call your service representative.
Power-On Self-Test failed. DEVICE FAILED is displayed in the display window.	<ul style="list-style-type: none"> • Verify that all tapes in the bulk load magazines are fully inserted in the magazines and that the magazines are securely locked into position inside the tape library. • Press the power switch off and then on again. (See the caution at the end of this table.) • If the power on test continues to fail, press ENTER, write down the displayed error code, and call your service representative for assistance.

continued

5-2 Troubleshooting

Troubleshooting *continued*

Problem	What to do
DEVICE FAILED is displayed in the display window. Hardware Error #61 (External SCSI cables) is reported.	<ul style="list-style-type: none">• Verify that the terminator is the correct type (single-ended).
The library's power-on self-test failed while a cartridge was in the drive. The library did not return to the drive status indicators ("ready" state) after the power came back on.	<ul style="list-style-type: none">• Press the power switch off and then on again. (See the caution at the end of this table.)• If the Power On test is unsuccessful, switch off the power. Call your service representative for assistance.
No display messages appear.	<ul style="list-style-type: none">• Make sure the power cord is connected.• Make sure the power switch is on.• Power cycle the library. (See the caution at the end of this table.)• If there is still no display, call your service representative for assistance.

continued

Troubleshooting *continued*

Problem	What to do
An error message is received after bulk loading tape cartridges.	<ul style="list-style-type: none"> • Verify that cartridges are inserted into the magazine in the correct orientation. • Verify that you are using the correct tape type. • If the light bar on the display panel is amber, cycle power to the library and try to load the magazine again when the drive numbers and status indicators are displayed. (See the caution at the end of this table.) • If SECURITY ENABLED displays, a security option has been set that prevents cartridges from being loaded into or removed from the library. • TRANSPORT FULL displays, the cartridge transport mechanism already contains a tape cartridge. Refer to your host documentation or call your service representative to remove the cartridge from the transport. • If a LOAD ERROR or FAILED message still displays, this could indicate a library failure; call your service representative for assistance.
Changed drive address but the new address is not recognized.	Try rebooting your host computer. Some computers require this for the new address to be recognized. (See the caution at the end of this table.)
Cannot remember your administration menu password.	First, try the default password (000-000-000). If the default is not accepted, call your service representative for assistance.

continued

5-4 Troubleshooting

Troubleshooting *continued*

Problem	What to do
Attempted to open the front access door, but a RESERVED message displays.	<ul style="list-style-type: none">• The host may have reserved an element and must unreserve it. Refer to your host system documentation to unreserve a tape.• A security configuration was set to prevent cartridge removal. See "SECURE ON/OFF" in the list of configurations found Chapter 4.
Started a test and need to stop.	Press. CANCEL The current test loop continues until finished, then the test stops.
DO INVENTORY TST displays (initialize element status).	<ul style="list-style-type: none">• Power cycle the library by pressing the power switch off and then on again. (See the caution at the end of this table.)• Run the INVENTORY CHECK test under the TEST* menu.
Cannot write to the tape.	<ul style="list-style-type: none">• Check the host file system access permissions.• Check the write-protect tab on the cartridge to assure write-enabled status.• Check your application software.
Cannot read the tape.	<ul style="list-style-type: none">• Check the host file system access permissions.• Verify that you are using the correct tape type• Check your application software.



CAUTION: Do not press the library power switch until you have shut down the peripherals connected to your computer by SCSI cables. Pressing the power button when the SCSI system is active can cause data loss and/or problems with the SCSI interface.

Appendix A

Regulatory Compliance Notices

Federal Communications Commission Notice

Part 15 of the Federal Communications Commission (FCC) Rules and Regulations has established Radio Frequency (RF) emission limits to provide an interference-free radio frequency spectrum. Many electronic devices, including computers, generate RF energy incidental to their intended function and are, therefore, covered by these rules. These rules place computers and related peripheral devices into two classes, A and B, depending upon their intended installation. Class A devices are those that may reasonably be expected to be installed in a business or commercial environment. Class B devices are those that may reasonably be expected to be installed in a residential environment (i.e., personal computers). The FCC requires devices in both classes to bear a label indicating the interference potential of the device as well as additional operating instructions for the user.

The rating label on the device shows which class (A or B) the equipment falls into. Class B devices have an FCC logo or FCC ID on the label. Class A devices do not have an FCC logo or ID on the label. Once the class of the device is determined, refer to the following corresponding statement.

Class A Equipment

This equipment has been tested and found to comply with the limits for a Class A digital device, pursuant to Part 15 of the FCC Rules. These limits are designed to provide reasonable protection against harmful interference when the equipment is operated in a commercial environment. This equipment generates, uses, and can radiate radio frequency energy and, if not installed and used in accordance with the instructions, may cause harmful interference to radio communications. Operation of this equipment in a residential area is likely to cause harmful interference, in which case the user will be required to correct the interference at personal expense.

Class B Equipment

This equipment has been tested and found to comply with the limits for a Class B digital device, pursuant to Part 15 of the FCC Rules. These limits are designed to provide reasonable protection against harmful interference in a residential installation. This equipment generates, uses, and can radiate radio frequency energy and, if not installed and used in accordance with the instructions, may cause harmful interference to radio communications. However, there is no guarantee that interference will not occur in a particular installation. If this equipment does cause harmful interference to radio or television reception, which can be determined by turning the equipment off and on, the user is encouraged to try to correct the interference by one or more of the following measures:

- Reorient or relocate the receiving antenna.
- Increase the separation between the equipment and receiver.
- Connect the equipment into an outlet on a circuit different from that to which the receiver is connected.
- Consult the dealer or an experienced radio or television technician for help.

Modifications

The FCC requires the user to be notified that any changes or modifications made to this device that are not expressly approved by Compaq Computer Corporation may void the user's authority to operate the equipment.

Cables

Connections to this device must be made with shielded cables with metallic RFI/EMI connector hoods in order to maintain compliance with FCC Rules and Regulations.

Canadian Notice (Avis Canadien)

Class A Equipment

This Class A digital apparatus meets all requirements of the Canadian Interference-Causing Equipment Regulations.

Cet appareil numérique de la classe A respecte toutes les exigences du Règlement sur le matériel brouilleur du Canada.

Class B Equipment

This Class B digital apparatus meets all requirements of the Canadian Interference-Causing Equipment Regulations.

Cet appareil numérique de la classe B respecte toutes les exigences du Règlement sur le matériel brouilleur du Canada.

European Union Notice

Products with the CE Marking comply with both the EMC Directive (89/336/EEC) and the Low Voltage Directive (73/23/EEC) issued by the Commission of the European Community.

Compliance with these directives implies conformity to the following European Norms (in brackets are the equivalent international standards):

- EN55022 (CISPR 22) - Electromagnetic Interference
 - EN50082-1 (IEC801-2, IEC801-3, IEC801-4) - Electromagnetic Immunity
 - EN60950 (IEC950) - Product Safety
 - EN60825 (IEC825) - Laser Equipment Safety
-

Japanese Notice

お使いになっている装置にVCCIマークが付いていましたら、次の説明文をお読み下さい。

この装置は、第二種情報装置（住宅地域又はその隣接した地域において使用されるべき情報装置）で住宅地域での電波障害防止を目的とした情報処理装置等電波障害自主規制協議会（VCCI）基準に適合しております。しかし、本装置をラジオ、テレビジョン受信機に近接してご使用になると、受信障害の原因となることがあります。取扱説明書に従って正しい取り扱いをして下さい。

VCCIマークが付いていない場合には、次の点にご注意下さい。

この装置は、商工業地域で使用されるべき第一種情報装置です。住宅地域又はその隣接した地域で使用するとラジオ、テレビジョン受信機等に受信障害を与えることがあります。

Laser Devices

The DLT Tape Library contains a laser device. All Compaq systems equipped with a laser device comply with safety standards, including International Electrotechnical Commission (IEC) 825. With specific regard to the laser, the DLT Library complies with laser product performance standards set by government agencies as a Class 1 laser product. The product does not emit hazardous light; the beam is totally enclosed during all modes of customer operation and maintenance.

Laser Safety Warnings



WARNING: To reduce the risk of fire, bodily injury, and damage to the equipment, observe the following precautions:

- Do not operate controls, make adjustments, or perform procedures to a laser device other than those specified herein or in the DLT Library installation guide.
 - Allow only Compaq Authorized Service Technicians to repair the DLT Library.
-

Compliance with CDRH Regulations

The Center for Devices and Radiological Health (CDRH) of the U.S. Food and Drug Administration implemented regulations for laser products on August 2, 1976. These regulations apply to laser products manufactured from August 1, 1976. Compliance is mandatory for products marketed in the United States.

Compliance with International Regulations

The DLT Tape Library comply with appropriate safety standards, including IEC 825.

Laser Product Label

The following label or equivalent is located on the rear panel of your DLT Tape Library drive.



This label indicates that the product is classified as a CLASS 1 LASER PRODUCT..

Laser Information

Laser Type	Semiconductor AlGaInP
Wave Length	674 nm
Sweep Angle	54.3 degrees
Output Power	Less than 0.5 mW
Scan Rate	52 Scans per second

Appendix B **Electrostatic Discharge**

A discharge of static electricity from a finger or other conductor may damage printed circuit boards or other static-sensitive devices. This type of damage may reduce the life expectancy of the device.

Preventing Electrostatic Damage

To prevent electrostatic damage, observe the following precautions:

- Avoid hand contact by transporting and storing parts in static-safe containers.
- Keep electrostatic-sensitive parts in their containers until they arrive at static-free work stations.
- Place parts on a grounded surface before removing them from their container.
- Avoid touching pins, leads, or circuitry.
- Always be properly grounded when touching a static-sensitive component or assembly.

Appendix C Specifications

This section provides operating and performance specifications for:

- DLT Library
- 15/30-GB DLT Tape Drive

**Table C-1
DLT Tape Library Specifications**

Performance	
Average tape access	<14 seconds
Average tape exchange	28 seconds (mean time to eject tape from drive, robotically exchange tape from magazine and reload drive.)
Reliability	
MTBF	100,000 hours
MSBF (robotics)	1 million swaps
Preventive maintenance	None required
Power Requirements	
Total power consumption	140 W (typical)
Rated Input voltage	150 W (maximum)
Rated Input current	2.5/1.5 A
Rated Input frequency	50 to 60 Hz
Line voltage	100 - 240 Vac

continued

▪
▪
C-2 *Specifications*

Tape Library Specifications *continued*

Rack-mount Library Product	
Interface	SCSI-2 (single-ended)
Height	356 mm (14 in.)
Width	445 mm (17.5 in.)
Depth	737 mm (29 in.)
Weight	44 kg (97 lbs)
Rack-mount Product Shipping	
Height	696 mm (27.5 in.)
Width	686 mm (27 in.)
Depth	1003 mm (39.5 in.)
Weight	60 kg (132 lbs)
Standalone Library Product	
Height	387 mm (15.5 in.)
Width	483 mm (19 in.)
Depth	737 mm (29 in.)
Weight	55 kg (121 lbs)
Panel Kit Shipping	
Height	178 mm (7 in.)
Width	686 mm (27 in.)
Depth	1003 mm (39.5 in.)
Weight	14 kg (31 lbs)

continued

Tape Library Specifications *continued*

Temperature and Humidity	
Operating	10° to 35 °C
	20% to 80% RH
Storage/Shipment	-30° to 60 °C
	(<14 consecutive days)
Gradient	10° C per hour
Shock	
Non-operating	30 g /206 ips (trapezoidal wave)
Vibration	
Operating random	0.21 g rms
Non-operating random	2.1 g rms
Non-operating swept-sine	0.5 g rms (0 to peak, swept-sine wave)
Acoustic Emissions	
Read/write operation	5.0 Bels
Safety	
	EN60950/IEC 950
Electromagnetic emissions	
	EN55022/CISPR-22, Class B, EN50082-1, EN55024-2/IEC 801-2, 4kV CD, 8kV AD, EN55024-3/IEC 801-3, 3 V/m, EN55024-4/IEC 801-4, 1kV Peak Power lines, 0,5 kV Signal lines, FCC 47 CFR Part 15 - Class "B", VCCI Level 1, EN61000-3-2/IEC 1000-3-2, EN61000-3-3/IEC 1000-3-3, ,
Laser	
	EN60825 (1991)/IEC 825 (1984) +A1, Laser Class 2

15/30-GB Library Ready Tape Drive Specifications *continued*

Blocks per Frame	variable
Percentage ECC	25%
Bytes per Group	64,000
Data Frame/Group	16
Recording Density/Inch	62,500
Tape Drive Characteristics	
Track Density/Inch	256
Encoding Method	(2,7) RLL
Native Data Transfer Rate	1.25 MB/sec
Error Correction	Reed Soloman (3 levels)
Read-Write Head	two-channel, ferrite with mig
Data Compression Algorithm	dlz

Appendix D

Power Cord Set Requirements

The power cord set meets the requirements for use in the country where you purchased your equipment.

Power cord sets for use in other countries must meet the requirements of the country where you use the equipment. For more information on power cord set requirements, contact your Compaq Reseller or Authorized Compaq Service Provider.

General Requirements

The requirements listed below are applicable to all countries:

- The length of the power cord must be at least 6 feet (1.8 m) and a maximum of 12 feet (3.7 m).
- The power cord set must be approved by an acceptable accredited agency responsible for evaluation in the country where the power cord will be used.
- The power cord set must have a minimum current capacity and nominal voltage rating of 10 A, 125 volts AC or 10A, 250 volts AC, as required by the power system in each country.

Country-Specific Requirements

Use the following table to identify the appropriate accredited agency in your country.

Table D-1
Power Cord Set Requirements - By Country

Country	Accredited Agency	Applicable Note Numbers
Australia	EANSW	1
Austria	OVE	1
Belgium	CEBC	1
Canada	CSA	2
Denmark	DEMKO	1
Finland	SETI	1
France	UTE	1
Germany	VDE	1
Italy	IMQ	1
Japan	JIS	3
Norway	NEMKO	1
Sweden	SEMKO	1
Switzerland	SEV	1
United Kingdom	BSI	1
United States	UL	2

Notes:

1. Flexible cord must be <HAR> Type HO5VV-F, 3-conductor, 1.0 mm² conductor size. Power cord set fittings (appliance coupler and wall plug) must bear the certification mark of the agency responsible for evaluation in the country where it will be used.
2. Flexible cord must be Type SJT or equivalent, No. 18 AWG, 3-conductor. Wall plug must be a two-pole grounding type with a NEMA 5-15P (15A, 125V).
3. Appliance coupler, flexible cord, and wall plug must bear a "T" mark and registration number in accordance with the Japanese Dentori Law. Power cord set minimum nominal rating must be 7A, 100 V. Flexible cord must be Type VCT or VCTF, 3-conductor, 1.0 mm² conductor size. Wall plug must be a two-pole grounding type with a Japanese Industrial Standard C8303 (15A, 125V) configuration.



Appendix E Getting Help

If you have a problem and have exhausted the information in this guide, you can get further information and other help in the following locations.

Compaq Web Site

The Compaq Web Site has information on this product as well as the latest drivers and Flash ROM images. You can access the Compaq Web Site by logging on to the Internet at <http://www.compaq.com>.

Telephone Numbers

Contact your nearest Compaq Authorized Reseller or Service Provider for more information.

- For the name of your nearest Compaq Authorized Reseller:
 - In the United States, call 1-800-345-1518
 - In Canada, call 1-800-263-5868
- For Compaq technical support:
 - In the United States and Canada, call 1-800-386-2172
 - Elsewhere, call one of the numbers listed below

Compaq Worldwide Technical Support Telephone Numbers

Location	Voice	FAX
APD	65-7503030	65-7504909
Argentina	54-1 313 3100	54-1 313 3100 Ext 21
Australia	61-2-9911-1955	61-2-9911-1900
Austria	0222-87816-16	0222-87816-82
Bahrain	973-210-214	
Belgium	(02) 716-96-96	(02) 725-22-13
Brazil	55 11 5505-3600	55 11 5505-3922 Ext 4336
Canada	1-800-386-2172	
Caribbean	1-800-345-1518	
Central America	281-378-2206	

Continued

E-2 Getting Help

Compaq Worldwide Technical Support Telephone Numbers Continued		
Location	Voice	FAX
Chile	562-274-3007	
China	86-10-834-6721	86-10-834-6713
Colombia	571-345-0266	571-312-0157
Czech Republic	42-2-232-8772	42-2-232-8773
Denmark	45-90-4545	45-90-4595
Equador	593-2504540	
Europe/Middle East/Africa	(49) 089-9933-2891	
Finland	9800-206-720 (+358-800-1-206720)	90-6155-9899 (+358-0-61559899)
France	(33 1) 41-33-4455	(33 1) 41-33-4263
Germany	0180-5-212111	089-9933-3399
Hong Kong	852-90116633	852-28671734
Hungary	36-1-201-8776	36-1-201-9696
India	(91-80) 559-6023	
Italy	392-57-90300	392-575-00686
Japan	0120-101589	+81 3-5402-5959
Korea	82-2-523-3575	82-2-3471-0321
Malaysia	(603) 718-1636	
Mexico	(525) 229-7910	(525) 229-7988
Netherlands	06-91681616	06-8991116
New Zealand	649-307-3969	
Norway	22-072-020	22-072-021
Poland	48-2-630-3535	48-2-630-3553
Portugal	351-1-4120132	351-1-4120654
Singapore	65-7503030	65-7504909
South Africa	+27-11-728-6999	+27-11-728-3335
Spain	341-640-1302	341-640-0124
Sweden	(46) 8 703 5240	(46) 8 703 5222
Switzerland	411 838 410/2222	01-837-0969
Taiwan	(886) 2-3761170	(886) 2-7322660
Thailand	62-2-679-6222	62-2-679-6220
United Kingdom	44-81-332-3888	44-81-332-3409
United States	1-800-386-2172	1-800-345-1518

Venezuela	(582) 953.69.44	(582) 952.86.70
-----------	-----------------	-----------------

Index

A

- Addresses, setting of SCSI 4-22 to 4-23
- Administration menus 4-7
- Administration mode 4-5
- Administration sub menus 4-5
- Attaching the slide rail 2-4

B

- Bar codes 3-3
 - labeling cartridges 3-3
 - labeling magazines 3-4
- Bulk load magazines 3-4

C

- Cable management arm 2-11
 - attaching 2-11
- Cartridge types 3-1
- Changing the current SCSI address 4-23
- Cleaning tape drives 4-20
- Compaq web site E-1
- Configuration option 4-18
 - changing 4-18
 - listing of 4-18
- Control panel menu 4-6
- Controls 4-1
- Controls and status indicators 4-2

D

- Display panel 4-2
- Display window messages 4-2
- DLT library overview 1-1

- Door release 4-5
- Drive cleaning issues 3-9
- Drive status symbols 4-3
- Driver 1-1

F

- Features 1-2
- Front panel controls 4-1

G

- Getting help E-1

H

- <http://www.compaq.com> E-1

I

- INFO menu 4-9
- Information logs 4-10
 - accessing 4-9
- Inserting cage nuts 2-3
- Installation
 - location 2-1
 - materials 2-1
- Installing the tape library 2-8
- Internal tests 4-14

J

- Jukeboxes 1-1

L

- Labeling bulk load magazines 3-4
- Library
 - connecting SCSI cables 2-13
 - performance information 4-9
 - changing configuration options 4-18

M

Menu tree 4-6
Messages, display window 4-2
Modes 4-4

O

Off Line Release Door 4-5
On-line Drive Replacement 4-25
Operational modes 4-4

P

Password 4-8
 default 4-7
 saving in ROM 4-9
Power cord set D-1

R

Replacing a drive 4-25

S

SCSI address
 changing the current 4-23
 setting 4-23
 current 4-24
SCSI cable
 connecting 2-13
 length limitations 2-13
SCSI ID's
 default 4-23
 setting 4-22
Second DLT tape drive 2-14
Setting, configuration option 4-18
Setting a new password 4-8
Setting SCSI IDs 4-22

Symbols

in text viii
on equipment viii

T

Tape cartridges 3-1, 3-8
 drive cleaning 3-9
 selecting 3-1
 write-protecting 3-2
Tape drives, cleaning 4-20
Telephone numbers E-1
Template 2-3
Tests, internal 4-13
Troubleshooting 5-1 to 5-4

V

Viewing current SCSI address 4-23

W

Write-protecting cartridges 3-2