

# HP StorageWorks EVA4x00/6x00/8x00 M5314 drive enclosure installation instructions

This document contains instructions for adding an M5314 drive enclosure to an existing EVA4x00/6x00/8x00 storage system cabinet. These instructions are not for adding a drive enclosure to an expansion cabinet.

© Copyright 2007 Hewlett-Packard Development Company, L.P.

Fifth edition: August 2007

The information in this document is subject to change without notice.

www.hp.com



## Adding a drive enclosure to an EVA8x00/6x00

This section contains the procedure for adding an M5314 drive enclosure to an EVA8x00 or EVA6x00 while the storage system is operating. The M5314A or M5314B is used with the EVA8000 and EVA6000. The M5314C drive enclosure is used with the EVA8100 and EVA6100.

### NOTE:

HP highly recommends that you perform this upgrade procedure during off-peak hours.

### WARNING!

A fully loaded drive enclosure with all components installed weighs more than 29.5 kg (65 lb.) and requires a minimum of two people to move. To safely and easily install the drive enclosure, remove the drives, power supplies, blowers, EMU, and I/O modules. This reduces the drive enclosure weight to approximately 11.0 kg (24 lb.). Even though a single person can lift this weight, the drive enclosure is difficult to install because of the physical size. Therefore, HP recommends that a minimum of two people install an empty drive enclosure in a rack.

Before you begin this hardware upgrade, you must verify that the Enterprise Virtual Array is functioning properly. Use HP Command View EVA to verify that each drive enclosure and disk drive has a good operational status. If a drive enclosure or disk drive does not have a good operational status, correct the problem.

1. If it is necessary to add an ID expansion cable to the cabinet address bus to accommodate the new drive enclosure, install the cable as follows:
  - a. Remove the top terminator from the cabinet address bus.
  - b. Connect the new ID expansion cable to the address bus.
  - c. Install the top terminator at the end of the new expansion cable.
2. Label each new FC cable with the labels contained in the drive enclosure kit. Each drive enclosure has two FC copper cables. Use the labeling scheme described in [Table 1](#).

**Table 1 FC cable labels**

Drive enclosure	FC cable labels	Drive enclosure	FC cable labels
1	8 and 14	8	20 and 26
2	9 and 15	9	21 and 27
3	10 and 16	10	22 and 28
4	11 and 17	11	23 and 29
5	12 and 18	12	24 and 30
6	13 and 19	13	25 and 31

3. If FC cable loop spools are used, carefully turn the captive fastener 1/4 turn and slide the cable loop off of the rail. Carefully, let the spool hang.
4. Remove the nearby velcro cable ties.
5. Cut the plastic ties on the drive enclosure power cables.

6. Install the drive enclosure snap-in rail kit (part number 302465-001).
7. Install the drive enclosure into the rack.
8. Insert and seat all disk drives and other components into the drive enclosure, but do not connect the cables.
9. Connect the AC power to the drive enclosure and do the following:
  - a. Wait for all FC disk drives to spin up.

**NOTE:**

The first drive in the drive enclosure might have the orange Drive Failure icon lit. This is expected behavior.

- b. Check the EMU alphanumeric display for errors. See [Figure 1](#). Resolve any errors.

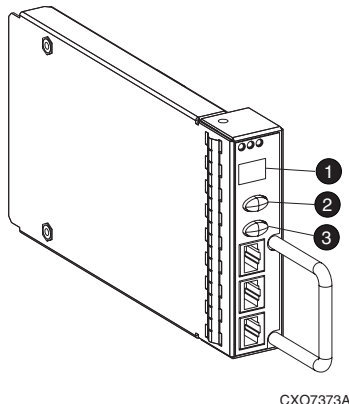

1. Alphanumeric display
2. Function select
3. Display group select

**Figure 1 EMU alphanumeric display and controls**

- c. Verify that the EMU displays 00, indicating that the drive enclosure is not connected to the enclosure address bus.
- d. Verify that the fan LEDs are on and steady. See [Figure 2](#).

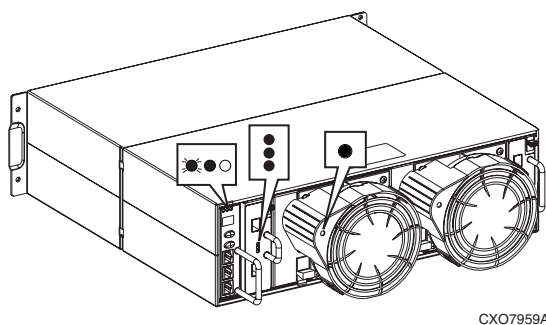

**Figure 2 Enclosure operational status indications**

- e. On both I/O modules, verify that the Power status indicator is on and steady. Verify that both port status indicators are off. See [Figure 3](#).
- f. Resolve any problems before proceeding to the next step.

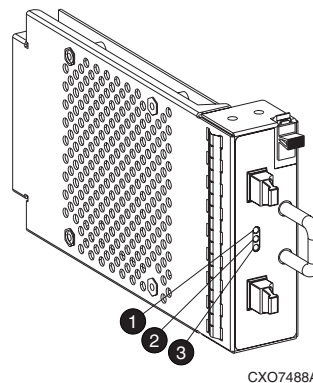

1. Upper port
2. Power
3. Lower port

**Figure 3 I/O module status indicators**

10. Check the operational status of the FC loops.
  - a. On the controller, verify that the A-side and B-side device port indicators are on and steady.
  - b. Resolve any problems before proceeding to the next step.
11. Remove the GBICs from the required ports on the A and B loop switches.
12. Using a copper FC cable, connect I/O module A to the appropriate A-side loop switch. The A-side of the rack is the right side of the rack, when viewed from the rear. See [Figure 4](#) and refer to [Table 2](#) and [Table 3](#) to determine which cables and port connections to use.
  - On an EVA8x00, the location of the drive enclosure in the rack determines the loop switch it connects to. Drive enclosures mounted in the lower half of the rack (enclosures 1 through 6) connect to loops 1A and 1B. Drive enclosures mounted in the upper half of the rack (enclosures 8 through 13) connect to loops 2A and 2B.
  - An EVA6x00 includes a single set of loop switches and all drive enclosures are connected to loops 1A and 1B.
  - a. Plug the FC cable into the correct port on the A-side loop switch.
  - b. Route the copper cable through the appropriate cable management arm and radial clip. Do not route the copper cables through flumes that contain fiber optic cables. Instead, route the copper cables through vacant flumes.

**CAUTION:**

When you are adding the copper cables to the rack, handle the fiber optic cables with care. If you are not careful, you can damage the fiber optic cables.

- c. Coil the excess copper cable and secure the cable behind the rail with cable ties.
- d. Plug the cable into I/O module A of the drive enclosure.

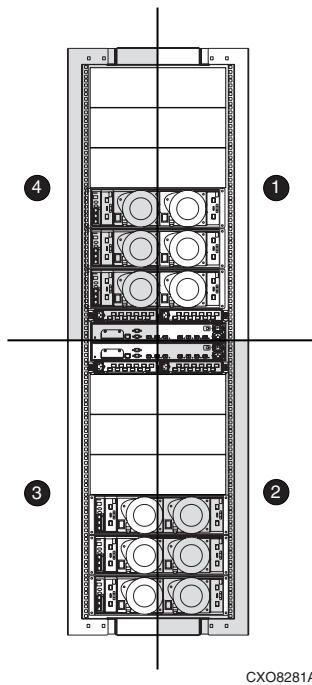

CXO8261A

- 1. Loop 2A
- 2. Loop 1A
- 3. Loop 1B
- 4. Loop 2B

**Figure 4 Loop locations in the Enterprise rack**

**Table 2 FC cable connections for I/O module A, loop 1A**

Drive enclosure	I/O module	FC cable	FC loop switch	FC loop switch port
1	A	8	1A	12
2	A	9	1A	10
3	A	10	1A	8
4	A	11	1A	6
5	A	12	1A	4
6	A	13	1A	2

**Table 3 FC cable connections for I/O module A, loop 2A**

Drive enclosure	I/O module	FC cable	FC loop switch	FC loop switch port
8	A	20	2A	1
9	A	21	2A	3
10	A	22	2A	5
11	A	23	2A	7
12	A	24	2A	9
13	A	25	2A	11

13. Verify that the FC connection is operating correctly.
- a. Verify that the green SFP Status LED on the FC loop switch is on and steady and the Port bypassed LED is off. See [Figure 5](#).
  - b. Verify that the corresponding port status indicator on I/O module A is on and steady.

- c. Verify that the corresponding A device port on the controller is on and steady.

**NOTE:**

The orange Drive Failure icon on the first drive in the drive enclosure is turned off.

- d. Verify that the upgraded configuration is working properly, using HP Command View EVA.
  - Verify that the added drive enclosure has a good status.
  - Verify that each disk drive in the added drive enclosure has a good status.
- e. Resolve any problems before proceeding to the next step.

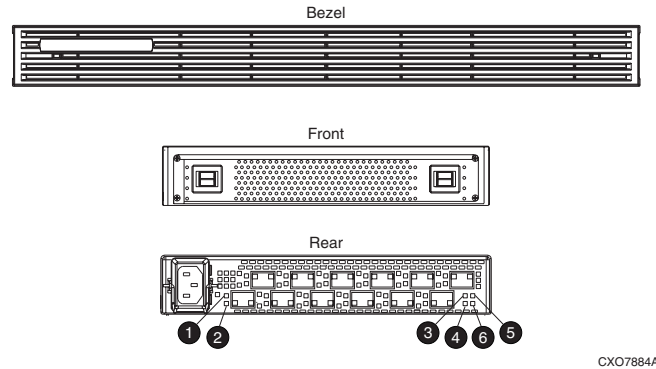

CXO7884A

- 1. SFP status
- 2. Port bypassed
- 3. POST fault
- 4. Over temp
- 5. Power
- 6. Loop operational

**Figure 5 FC loop switch status indicators**

14. Using a copper FC cable, connect I/O module B to the appropriate B-side loop switch. The B-side of the rack is the left side of the rack when viewed from the rear. See [Table 4](#) and [Table 5](#) to determine which cables and port connections to use.

**CAUTION:**

Make sure you are connecting the drive enclosure to corresponding loop switches. If you used loop switch 1A for port A, then you must use loop switch 1B. If you used loop switch 2A, then you must use loop switch 2B. If you fail to connect the drive enclosure to corresponding loop switches, you can make the data in the other drive enclosures inaccessible.

- a. Plug the FC cable into the correct port on the B-side loop switch.
- b. Route the copper cable through the appropriate cable management arm and radial clip. Do not route the copper cables through flumes that contain fiber optic cables. Instead, route the copper cables through vacant flumes.

**CAUTION:**

When you are adding the copper cables to the rack, handle the fiber optic cables with care. If you are not careful, you can damage the fiber optic cables.

- c. Coil the excess copper cable and secure the cable behind the rail with cable ties.

- d. Plug the cable into I/O module B of the drive enclosure.

**Table 4 FC cable connections for I/O module B, loop 1B**

Drive enclosure	I/O module	FC cable	FC loop switch	FC loop switch port
1	B	14	1B	2
2	B	15	1B	4
3	B	16	1B	6
4	B	17	1B	8
5	B	18	1B	10
6	B	19	1B	12

**Table 5 FC cable connections for I/O module B, loop 2B**

Drive enclosure	I/O module	FC Ccable	FC loop switch	FC loop switch port
8	B	26	2B	11
9	B	27	2B	9
10	B	28	2B	7
11	B	29	2B	5
12	B	30	2B	3
13	B	31	2B	1

- Verify that the FC connection is operating correctly.
  - Verify that the green SFP Status LED on the FC loop switch is on and steady and the Port bypassed LED is off.
  - Verify that the corresponding port status indicator on I/O module B is on and steady.
  - Verify that the corresponding B device port on the controller is on and steady.
  - Resolve any problems before proceeding to the next step.
- Connect the newly added drive enclosure to the enclosure address bus. See [Figure 6](#) for the enclosure numbering.

**NOTE:**

- CAB address ports 8 and 14 share a common address. When adding a drive enclosure to loop 2 on an EVA8x00, make sure drive enclosures are connected to either port 8 or port 14. You can use one or the other but not both. Using both of these ports on the same loop makes it difficult to analyze disk problems because the disks in the drive enclosure connected to ports 8 and 14 appear to have the same addresses.
- When adding a drive enclosure to an EVA6x00, do not use address port 7 for the enclosure. Address port 7 does not receive a hard AL-PA range.

- Verify that the EMU displays a unique enclosure number.
- Verify that the EMUs on the other drive enclosures continue to display valid enclosure numbers.
- Wait 15 minutes.
- Verify that HP Command View EVA displays the recently added drive enclosure under the Rack element in the

Navigation pane. It should no longer be in the Unmappable Hardware folder.

- Verify that the upgraded configuration is working properly, using HP Command View EVA.
  - Verify that the added drive enclosure has a good status.
  - Verify that each disk drive in the added drive enclosure has good status.

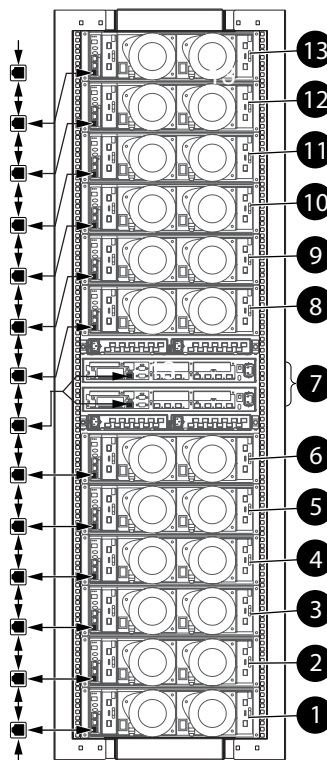

0046a-2

**Figure 6 Enclosure numbering**

- Repeat the above steps to add each drive enclosure.
- Use nylon ties to secure the copper FC cables.
- In HP Command View EVA, configure the additional storage capacity. See the *HP StorageWorks 4x00/6x00/8x00 Enterprise Virtual Array user guide* and the EVA Best Practices white paper for information on using the new disk capacity.

## Adding a drive enclosure to an EVA4x00

This section contains the procedure for adding an M5314 drive enclosure to an EVA4x00 while the storage system is operating. The M5314A or M5314B is used with the EVA4000. The M5314C drive enclosure is used with the EVA4100.

**NOTE:**

HP highly recommends that you perform this upgrade procedure during off-peak hours.

---

**⚠ WARNING!**

A fully loaded drive enclosure with all components installed weighs more than 29.5 kg (65 lb.) and requires a minimum of two people to move. To safely and easily install the drive enclosure, remove the drives, power supplies, blowers, EMU, and I/O modules. This reduces the drive enclosure weight to approximately 11.0 kg (24 lb.). Even though a single person can lift this weight, the drive enclosure is difficult to install because of the physical size. Therefore, HP recommends that a minimum of two people install an empty drive enclosure in a rack.

---

Before you begin this hardware upgrade, you must verify that the Enterprise Virtual Array is functioning properly. Use HP Command View EVA to verify that each drive enclosure and disk drive has a good operational status. If a drive enclosure or disk drive does not have a good operational status, correct the problem.

1. Label each new FC cable with the labels contained in the drive enclosure kit. Each drive enclosure has two FC copper cables.
2. If FC cable loop spools are used, carefully turn the captive fastener 1/4 turn and slide the cable loop off of the rail. Carefully, let the spool hang.
3. Remove the nearby velcro cable ties.
4. Cut the plastic ties on the drive enclosure power cables.
5. Install the snap-in rail kit (part number 302465-001).
6. Install the drive enclosure into the rack.
7. Insert and seat all drives and other components into the drive enclosure, but do not connect the cables.
8. Connect the AC power to the drive enclosure and do the following.
  - a. Wait for all FC disk drives to spin up.

---

**📄 NOTE:**

The first drive in the drive enclosure might have the orange Drive Failure icon lit. This is expected behavior.

---

- b. Check the EMU alphanumeric display for errors. See [Figure 1](#). Resolve any errors.
  - c. Verify that the EMU displays 00, indicating that the drive enclosure is not connected to the enclosure address bus.
  - d. Verify that the fan LEDs are on and steady. See [Figure 2](#).
  - e. On both I/O modules, verify that the Power status indicator is on and steady. Verify that both port status indicators are off. See [Figure 3](#).
  - f. Resolve any problems before proceeding to the next step.
9. Check the operational status of the FC loops.
  - a. On the controller, verify that the A-side and B-side device port indicators are on and steady.
  - b. Resolve any problems before proceeding to the next step.

---

**⚠ CAUTION:**

As long as one I/O loop (1A or 1B) is operational, storage system operation will not be interrupted. Make sure you disconnect only one loop at a time. Make sure a loop is operational before disconnecting the other loop.

---

10. Connect the new drive enclosure to I/O loop 1A:

- a. Disconnect the FC cable from device port DP1A on the upper storage system controller.
  - b. Connect this cable to the lower port on I/O module A of the new drive enclosure.
  - c. Connect a FC cable from the upper port on I/O module A of the new drive enclosure to device port DP1A on the upper storage system controller.

11. Verify that loop 1A is operating correctly.

- a. Verify that the upper and lower port LEDs on I/O module A are on and steady.
  - b. Verify that device port DP1A on the controller is on and steady.

---

**📄 NOTE:**

The orange Drive Failure icon on the first drive in the drive enclosure is turned off.

---

- c. Verify that the upgraded configuration is working properly, using HP Command View EVA.
    - Verify that the added drive enclosure has a good status.
    - Verify that each disk drive in the added drive enclosure has a good status.
  - d. Resolve any problems before proceeding to the next step.

12. Connect the new drive enclosure to I/O loop 1B:

- a. Disconnect the FC cable from device port DP1B on the lower storage system controller.
  - b. Connect this cable to the lower port on I/O module B of the new drive enclosure.
  - c. Connect a FC cable from the upper port on I/O module B of the new drive enclosure to device port DP1B on the lower storage system controller.

13. Verify that loop 1B is operating correctly.

- a. Verify that the upper and lower port LEDs on I/O module B are on and steady.
  - b. Verify that device port DP1B on the controller is on and steady.
  - c. Resolve any problems before proceeding to the next step.

14. Connect the newly added drive enclosure to the enclosure address bus. See [Figure 6](#) for the enclosure numbering.

- a. Verify that the EMU displays a unique enclosure number.
  - b. Verify that the EMUs on the other drive enclosures continue to display valid enclosure numbers.
  - c. Wait 15 minutes.
  - d. Verify that HP Command View EVA displays the recently added drive enclosure under the Rack element in the Navigation pane. It should no longer be in the Unmappable Hardware folder.
  - e. Verify that the upgraded configuration is working properly, using HP Command View EVA.
    - Verify that the added drive enclosure has a good status.
    - Verify that each disk drive in the added drive enclosure has good status.

15. Repeat the preceding steps to add additional drive enclosures.

16. In HP Command View EVA, configure the additional storage capacity. See the *HP StorageWorks 4x00/6x00/8x00 Enterprise Virtual Array user guide* and the EVA Best Practices white paper for information on using the new disk capacity.