

HP MSM7xx Controllers Configuration Guide

Abstract

This document describes how to configure and manage the MSM7xx Controllers. This document applies to the MSM720, MSM760, MSM765 zl, and MSM775 zl Controllers. These products are hereafter referred to generically as *controller*.

HP Part Number: 5998-5809
Published: May 2014
Edition: 1



© Copyright 2014 Hewlett-Packard Development Company, L.P.

The information contained herein is subject to change without notice. The only warranties for HP products and services are set forth in the express warranty statements accompanying such products and services. Nothing herein should be construed as constituting an additional warranty. HP shall not be liable for technical or editorial errors or omissions contained herein.

Acknowledgments

Microsoft®, Windows®, and Windows XP® are U.S. registered trademarks of the Microsoft group of companies. Java® is a registered trademark of Oracle and/or its affiliates. Apple® and Bonjour® are trademarks of Apple Inc.



Warranty

WARRANTY STATEMENT: See the warranty information sheet provided in the product box.

Contents

1	Introduction.....	15
	New in release 6.4.0.0.....	15
2	Using the management tool.....	16
	Starting the management tool.....	16
	Using automated workflows.....	16
	Setting up manager and operator accounts.....	18
	Administrative user authentication.....	20
	Passwords.....	21
	Configuring management tool security.....	21
	Configuring the Login page message.....	22
	Configuring Auto-refresh.....	23
	Setting the system time.....	23
	LEDs.....	24
	Power saving.....	24
	Identify chassis.....	24
3	Dashboard.....	25
	Wireless clients tab.....	26
	Access Points tab.....	28
	Access Points Utilization tab.....	29
	Alarms tab.....	30
4	Network configuration.....	32
	Working with network profiles.....	32
	About the default network profiles.....	32
	To define a new network profile.....	33
	Configuring IP interfaces.....	33
	To assign an IP address to a new interface on the MSM720.....	34
	To assign an IP address to a new interface on other controllers.....	36
	Configuring the Access network/LAN port interface.....	38
	Configuring the Internet network/Internet port interface.....	39
	Configuring port settings.....	42
	Configuring MSM720 ports.....	43
	Configuring the LAN/Internet port on the MSM760.....	44
	Configuring the LAN/Internet port on the MSM765 zl and MSM775 zl.....	44
	Configuring DHCP services.....	44
	Configuring the global DHCP server.....	45
	Configuring the DHCP relay agent.....	48
	Configuring GRE tunnels.....	50
	Bandwidth control.....	51
	Data rate limits.....	52
	Bandwidth levels.....	52
	Example.....	53
	Discovery protocols.....	53
	CDP configuration.....	54
	LLDP configuration.....	55
	DNS configuration.....	58
	DNS servers.....	59
	DNS advanced settings.....	59
	Defining IP routes.....	60
	Configuring IP routes.....	60
	Network address translation.....	62

NAT security and static mappings.....	63
VPN One-to-one NAT.....	65
IP QoS.....	65
Configuring IP QoS profiles.....	65
Example.....	66
Customizing DiffServ DSCP mappings.....	68
IGMP proxy.....	68
5 Port trunking.....	70
Deployment considerations.....	71
Static trunks.....	72
Dynamic trunks.....	72
Creating a static trunk.....	72
Creating a dynamic trunk.....	75
6 Wireless configuration.....	80
Wireless coverage.....	80
Factors limiting wireless coverage.....	80
Configuring overlapping wireless cells.....	81
Automatic transmit power control.....	84
Supporting 802.11a and legacy wireless clients.....	84
Radio configuration.....	85
Radio configuration parameters.....	87
Advanced wireless settings.....	96
Neighborhood scanning.....	101
Viewing wireless information.....	102
Viewing all wireless clients.....	102
Viewing info for a specific wireless client.....	103
Viewing wireless client data rates.....	103
Wireless access points.....	107
7 Working with VSCs.....	112
Key concepts.....	112
Binding VSCs to APs.....	112
Viewing and editing VSC profiles.....	112
The default VSC.....	113
VSC configuration options.....	113
About access control and authentication.....	114
Summary of VSC configuration options.....	116
Access control.....	116
Virtual AP.....	117
VSC ingress mapping.....	122
VSC egress mapping.....	123
Bandwidth control.....	123
Default user data rates.....	124
Wireless mobility.....	124
Fast wireless roaming.....	125
Wireless security filters.....	126
Wireless protection.....	127
802.1X authentication.....	130
RADIUS authentication realms.....	131
HTML-based user logins.....	132
VPN-based authentication.....	132
MAC-based authentication.....	132
Location-aware.....	133
Wireless MAC filter.....	133

Wireless IP filter.....	134
DHCP server.....	134
DHCP relay agent.....	135
VSC data flow.....	135
Access control enabled.....	136
Access control disabled.....	137
Using multiple VSCs.....	138
About the default VSC.....	139
Quality of service.....	139
Priority mechanisms.....	140
IP QoS profiles.....	141
Upstream DiffServ tagging.....	142
Upstream/downstream traffic marking.....	142
QoS example.....	143
Creating a new VSC.....	144
Assigning a VSC to a group.....	144
8 Working with controlled APs.....	145
Key concepts.....	145
Plug and play installation.....	145
Automatic software updates.....	145
Centralized configuration management.....	145
Manual provisioning.....	145
Secure management tunnel.....	145
AP authentication.....	145
AP licensing.....	146
Key controlled-mode events.....	146
Discovery of controllers by controlled APs.....	148
Discovery overview.....	148
Discovery methods.....	149
Discovery order.....	150
Discovery recommendations.....	151
Discovery priority.....	152
Discovery considerations.....	154
Monitoring the discovery process.....	154
Authentication of controlled APs.....	159
Building the AP authentication list.....	160
Configuring APs.....	162
Overview.....	162
Inheritance.....	163
Configuration strategy.....	164
Working with groups.....	164
Working with APs.....	165
Assigning egress VLANs to a group.....	170
Assigning country settings to a group.....	170
Provisioning APs.....	171
Provisioning methods.....	171
Displaying the provisioning pages.....	172
Provisioning connectivity.....	173
Provisioning discovery.....	175
Provisioning summary.....	177
Provisioning example.....	177
AP survivability.....	178
VSC services.....	178
Switch ports.....	178

AeroScout RTLS.....	179
To enable AeroScout support.....	179
Viewing status information.....	180
Software retrieval/update.....	180
Monitoring.....	181
9 Radio Resource Management.....	182
Supported products.....	182
Mitigation of poor RF performance.....	183
AP/radio down detection and mitigation.....	183
Severe interference detection and mitigation.....	183
Spectrum analysis.....	184
Defining RRM scanning settings for a radio.....	184
Neighborhood scanning settings.....	186
Viewing the RRM radio map.....	187
Filter all entries by.....	187
Configuring and conducting RRM analysis.....	188
Configuring RRM options.....	189
Running an analysis manually.....	192
Working with baselines.....	193
10 Intrusion detection system (IDS).....	196
Supported products.....	196
AP classification.....	196
Wireless client classification.....	197
Threat detection.....	197
IDS modes.....	198
Deployment strategy.....	199
Rogue detection example.....	199
Configuration considerations for VoIP traffic.....	200
Teaming considerations.....	200
Starting IDS.....	200
Customizing scanning settings.....	202
Viewing IDS results.....	203
IDS page.....	203
Mis-associated client stations page.....	204
Ad-hoc cells page.....	205
Neighborhood page.....	206
Manually changing AP radio classification.....	209
Importing/exporting IDS classifications.....	210
11 Events and alarms.....	211
Supported products.....	211
Events.....	211
Filter events by.....	212
Table.....	212
Button.....	213
Alarms.....	213
Viewing/managing alarms.....	213
Configuring SNMP notifications for events and alarms.....	215
12 Working with VLANs.....	218
Key concepts.....	218
VLAN usage.....	218
Defining a VLAN.....	219
Defining a VLAN on a controller port.....	219
Assigning VLANs to controlled APs.....	220

User-assigned VLANs.....	221
VLAN assignment via RADIUS.....	221
VLAN assignment via the local user accounts.....	221
Traffic flow for wireless users.....	221
Binding to a VSC that has Wireless mobility disabled.....	222
Binding to a VSC that has Wireless mobility and Mobility traffic manager enabled.....	224
Binding to a VSC that has Wireless mobility and Subnet-based mobility enabled.....	225
Terms used in the tables.....	226
Traffic flow examples.....	226
13 Managing Bonjour traffic.....	230
Overview.....	230
Supported products.....	230
Limitations.....	231
Important.....	231
Bonjour gateway.....	231
Access-controlled VSCs.....	231
Non-access-controlled VSCs.....	233
Configuring Bonjour gateway.....	234
Bonjour traffic management.....	235
Examples.....	235
Configuring traffic management.....	237
Bonjour traffic filtering.....	238
Filter evaluation.....	239
Defining a filter profile.....	239
Assigning filter profile.....	244
14 Controller teaming.....	246
Teaming overview.....	246
Teaming on the MSM760, MSM765 zl, and MSM775 zl.....	246
Teaming on the MSM720.....	246
Key concepts.....	246
Centralized configuration management.....	246
Centralized monitoring and operation.....	247
Redundancy and failover support.....	247
Scalability.....	247
Deployment considerations.....	247
Unsupported features.....	249
Creating a team.....	249
About the team management IP address.....	250
Configuration examples.....	250
Controller discovery.....	261
Monitoring the discovery process.....	262
Viewing discovered controllers.....	265
Viewing team members.....	266
Team configuration.....	267
Accessing the team manager.....	267
Team configuration options.....	267
Removing a controller from a team.....	268
Editing team member settings.....	269
Discovery of a controller team by controlled APs.....	271
Failover.....	271
Supporting N + N redundancy.....	271
Primary team manager failure.....	272
Mobility support.....	273
Single controller team operating alone.....	274

Single controller team operating with non-teamed controllers.....	275
Multiple teamed and non-teamed controllers.....	276
Guest access and teaming.....	276
Guest access with teamed controllers using the same subnet.....	280
15 Mobility traffic manager.....	285
Key concepts.....	285
The mobility domain.....	287
Home networks.....	288
Local networks.....	289
Mobility controller discovery.....	289
Network requirements.....	290
Controller discovery and teaming.....	290
Configuring Mobility Traffic Manager.....	290
Defining the mobility domain.....	291
Defining network profiles.....	292
Assigning a home network to a user.....	292
Defining local networks on a controller.....	293
Assigning local networks to an AP.....	293
Configuring the mobility settings for a VSC.....	294
Binding a VSC to an AP.....	295
Monitoring the mobility domain.....	295
Controllers.....	296
Networks in the mobility domain.....	296
Mobility clients.....	297
Forwarding table.....	297
Mobility client event log.....	298
Scenario 1: Centralizing traffic on a controller.....	299
How it works.....	299
Configuration overview.....	300
Scenario 2: Centralized traffic on a controller with VLAN egress.....	301
How it works.....	301
Configuration overview.....	302
Scenario 3: Centralized traffic on a controller with per-user traffic routing.....	304
How it works.....	304
Configuration overview.....	305
Scenario 4: Assigning home networks on a per-user basis.....	312
How it works.....	312
Configuration overview.....	313
Scenario 5: Traffic routing using VLANs.....	316
How it works.....	316
Configuration overview.....	318
Scenario 6: Distributing traffic using VLAN ranges.....	323
How it works.....	323
Configuration overview.....	325
Subnet-based mobility.....	330
16 User authentication, accounts, and addressing.....	331
Introduction.....	331
Authentication support.....	331
Other access control methods.....	332
Using more than one authentication type at the same time.....	332
User authentication limits.....	334
802.1X authentication.....	334
Supported 802.1X protocols.....	335
Configuring 802.1X support on a VSC.....	336

Configuring global 802.1X settings for wired users.....	338
Configuring global 802.1X settings for wireless users.....	338
Configuring 802.1X support on an HP 517 or MSM317 switch port.....	339
MAC-based authentication.....	339
MAC-based filtering.....	340
Configuring global MAC-based authentication.....	341
Configuring MAC-based authentication on a VSC.....	342
Configuring MAC-based authentication on an HP 517 or MSM317 switch port.....	343
Configuring global MAC lockout.....	344
Configuring MAC-based filters on a VSC.....	344
Configuring MAC-based filters on an HP 517 or MSM317 switch port.....	345
Configuring MAC address lists.....	346
Configuring MAC address format.....	347
HTML-based authentication.....	347
Configuring HTML-based authentication on a VSC.....	348
VPN-based authentication.....	349
Configuring VPN-based authentication on a VSC.....	350
No authentication.....	350
Locally-defined user accounts.....	350
Features.....	351
Defining a user account.....	355
Defining account profiles.....	357
Defining subscription plans.....	358
Accounting persistence.....	359
User addressing and related features.....	360
17 Authentication services.....	361
Introduction.....	361
Using the integrated RADIUS server.....	361
Primary features.....	361
Server configuration.....	362
User account configuration.....	363
Using a third-party RADIUS server.....	364
Configuring a RADIUS server profile.....	364
Authenticating manager logins using a third-party RADIUS server.....	368
Using an Active Directory server.....	369
Supported protocols.....	369
Active Directory configuration.....	369
Configuring an Active Directory group.....	371
Configuring a VSC to use Active Directory.....	373
18 Security.....	374
Firewall.....	374
Firewall presets.....	374
Firewall configuration.....	375
Customizing the firewall.....	376
Managing certificates.....	376
Trusted CA certificate store.....	377
Certificate and private key store.....	378
Certificate usage.....	380
About certificate warnings.....	381
IPSec certificates.....	381
Certificate expiration alerts.....	383
19 Local mesh.....	384
Key concepts.....	384

Simultaneous AP and local mesh support.....	384
Using 802.11a/n for local mesh.....	385
Local mesh terminology.....	385
Local mesh operational modes.....	386
Node discovery.....	386
Operating channel.....	386
Local mesh profiles.....	387
Configuration guidelines.....	387
Configuring a local mesh profile.....	387
Provisioning local mesh links.....	391
Sample local mesh deployments.....	393
RF extension.....	393
Building-to-building connection.....	394
Dynamic network.....	394
20 Public/guest network access.....	396
Introduction.....	396
Key concepts.....	396
Access control.....	396
Access lists.....	397
The public access interface.....	397
Location-aware.....	399
Configuring global access control options.....	399
User authentication.....	400
Client polling.....	401
User agent filtering.....	402
Zero configuration.....	402
Location configuration.....	402
Display advertisements.....	403
Public access interface control flow.....	403
Customizing the public access interface.....	405
Sample public access pages.....	406
Common configuration tasks.....	406
Setting site configuration options.....	409
About ASP variables.....	409
Allow subscription plan purchases.....	409
Display the Free Access option.....	410
Support a local Welcome page.....	411
Use frames when presenting ads.....	411
Allow SSLv2 authentication.....	412
Redirect users to the Login page via.....	412
Customizing the public access Web pages.....	412
Site file archive.....	412
FTP server.....	413
Current site files.....	414
Configuring the public access Web server.....	419
Options.....	419
Ports.....	420
MIME types.....	420
Security.....	421
Managing payment services.....	421
Payment services configuration.....	421
Service settings.....	422
Billing record logging.....	427
Settings.....	428

Persistence.....	428
External billing records server profiles.....	429
Billing records log.....	431
Table.....	431
Location-aware authentication.....	432
How it works.....	432
Example.....	433
Security.....	434
21 Working with RADIUS attributes.....	435
Introduction.....	435
Controller attributes overview.....	435
Customizing the public access interface using the site attribute.....	435
Defining and retrieving site attributes.....	436
Controller attribute definitions.....	438
User attributes.....	443
Customizing user accounts with the user attribute.....	443
Defining and retrieving user attributes.....	443
Retrieving attributes from a RADIUS server.....	447
PCM IDM support.....	447
User attribute definitions.....	448
Access request.....	449
Access accept.....	451
Access reject.....	453
Access challenge.....	453
Accounting request.....	454
Accounting response.....	457
Administrator attributes.....	457
Access request.....	457
Access accept.....	458
Colubris AV-Pair - Site attribute values.....	458
Access list.....	460
Configuration file.....	467
Custom SSL certificate.....	467
Custom public access interface Web pages.....	468
Default user interim accounting update interval.....	472
Default user bandwidth level.....	473
Default user idle timeout.....	473
Default user quotas.....	473
Default user data rates.....	474
Default user one-to-one NAT.....	474
Default user session timeout.....	474
Default user public IP address.....	475
Default user SMTP server.....	475
Default user URLs.....	475
HTTP proxy upstream.....	475
IPass login URL.....	476
Global MAC-based authentication.....	476
Multiple login servers.....	477
Redirect URL.....	479
NOC authentication.....	480
HP WISPr support.....	481
Traffic forwarding (dnat-server).....	482
Multiple DNAT servers.....	482
Colubris AV-Pair - User attribute values.....	484

Access list.....	484
Advertising.....	485
Bandwidth level.....	485
Data rate.....	485
One-to-one NAT.....	486
Public IP address.....	486
Quotas.....	486
Redirect URL.....	487
SMTP redirection.....	487
Station polling.....	488
Custom public access interface Web pages.....	488
Placeholders.....	489
Colubris AV-Pair - Administrator attribute values.....	489
Administrative role.....	490
Public access interface ASP functions and variables.....	490
Javascript syntax.....	490
Forms.....	491
Form errors.....	493
RADIUS.....	494
Page URLs.....	495
Session status and properties.....	495
iPass support.....	498
Web.....	499
Client information.....	500
Subscription plan information.....	502
Other.....	502
Session information.....	504
22 Working with VPNs.....	507
Overview.....	507
Securing wireless client sessions with VPNs.....	507
Configure an IPSec profile for wireless client VPN.....	509
Configure L2TP server for wireless client VPN.....	510
Configure PPTP server for wireless client VPN.....	510
VPN address pool.....	510
Securing controller communications to remote VPN servers.....	511
Configure an IPSec policy for a remote VPN server.....	512
Configure PPTP client for a remote VPN server.....	513
Keeping user traffic out of the VPN tunnel.....	514
Additional IPSec configuration.....	514
VPN one-to-one NAT.....	515
23 LLDP.....	517
Overview.....	517
LLDP-MED.....	517
Local mesh.....	518
SNMP support.....	518
Configuring LLDP on the controller.....	518
LLDP agents.....	519
LLDP settings.....	519
Port description TLV content.....	519
Generate dynamic system names.....	520
TLV settings.....	520
Basic TLVs.....	521
802.3 TLVs.....	521
Configuring LLDP on an AP.....	522

LLDP agent.....	522
Media endpoint discovery (MED) features.....	523
LLDP settings.....	524
Application type profiles.....	525
24 sFlow.....	527
Overview.....	527
sFlow proxy.....	527
sFlow agent support.....	527
MIB support.....	528
Configuring and activating sFlow.....	528
Status light.....	528
Global settings.....	528
Advanced sFlow configuration.....	529
25 Working with autonomous APs.....	533
Key concepts.....	533
Autonomous AP detection.....	533
Viewing autonomous AP information.....	533
Switching a controlled AP to autonomous mode.....	534
Configuring autonomous APs.....	535
VSC definitions.....	535
Working with third-party autonomous APs.....	536
VSC selection.....	536
26 Maintenance.....	538
Config file management.....	538
Manual configuration file management.....	538
Scheduled operations.....	539
Software updates.....	539
Performing an immediate software update.....	540
Performing a scheduled software update.....	540
Managing licenses.....	541
Installed licenses.....	541
License management.....	542
Generating and installing a feature license.....	542
27 Support and other resources.....	545
Online documentation.....	545
Contacting HP.....	545
HP websites.....	545
Typographic conventions.....	545
A Console ports.....	546
Overview.....	546
Using the console port.....	546
To reset manager credentials on a controller.....	546
B Resetting to factory defaults.....	547
How it works.....	547
Using the reset button.....	547
Using the management tool.....	547
Using the Console (serial) port.....	547
C NOC authentication.....	549
Main benefits.....	549
How it works.....	549
Activating a remote login page with NOC authentication.....	550
Addressing security concerns.....	551

Securing the remote login page.....	551
Authenticating with the login application.....	552
Authenticating the controller.....	552
NOC authentication list.....	552
Setting up the certificates.....	552
Install certificates on the Web server.....	552
Define attributes.....	552
Install a certificate on controller.....	553
Authenticating users.....	553
Returned values.....	554
Examples of returned HTML code.....	556
Simple NOC authentication example.....	556
Forcing user logouts.....	557
D DHCP servers and Colubris vendor classes.....	558
Overview.....	558
Windows Server 2003 configuration.....	558
Creating the vendor class.....	558
Defining vendor class options.....	559
Applying the vendor class.....	560
ISC DHCP server configuration.....	562

1 Introduction

This guide describes how to configure and manage HP MSM7xx Controllers. This document applies to the MSM720, MSM760, and MSM765 zl, and MSM775 zl Controllers. These products are hereafter referred to generically as *controller*.

See also the MSM7xx Controller Installation Guide specific to your controller model for details on how to install and initially configure your controller.

New in release 6.4.0.0

Information on what is new and changed in release 6.4.0.0 is located as follows:

New or changed in this release	For information, see...
Dashboard: The dashboard feature provides a wide variety of information about the operation of the wireless network using charts and graphs.	"Dashboard" (page 25)
New AP: This release adds support for the HP 517 802.11ac Unified Walljack, which features a single dual-band 3x3:3 802.11a/b/g/n/ac radio and integrated 4-port switch.	"Wireless mode" (page 89)
Free access lock out time: The free access lock out time feature has been added to the Controller >> Public access > Web content page. It enables administrators to specify how many hours a user is blocked from using the free account option after their initial free account expires.	"Free access lock out time <i>nn</i> hours" (page 410)
MAC address formatting: The format used for defining MAC addresses in a user account, or sent to a remote RADIUS server, can now be specified.	"Configuring MAC address format" (page 347)
Parameter renamed: The parameter Allow 802.11n clients only on the radio page has been renamed to Client restriction and new settings have been added to support 802.11ac clients on the HP 517.	"Client restriction" (page 96)
Admin Down parameter: A new parameter, called Admin Down, has been added. This parameter can be used to flag an AP that is offline for a known reason (such as maintenance, relocation) to differentiate it from other APs that are offline for unknown reasons (network failure, power failure, or other issues that prevent them from communicating with the controller).	"Viewing all configured APs" (page 158)

2 Using the management tool

Starting the management tool

Using Microsoft Internet Explorer 8+ or Mozilla Firefox 3+ (with SSL v3 support enabled), open page: **https://192.168.1.1** and then log in. This assumes you are connected to the LAN port on the controller (ports 1, 2, 3, or 4 on the MSM720).

About passwords:

The default username and password is **admin**. New passwords must be 6 to 16 printable ASCII characters in length with at least 4 different characters. Passwords are case sensitive. Space characters and double quotes (") cannot be used. Passwords must also conform to the selected security policy as described in "Passwords" (page 21).

About the security warning:

A security certificate warning is displayed the first time that you connect to the management tool. This is normal. Select whatever option is needed in your Web browser to continue to the management tool. The default certificate provided with the controller will trigger a warning message on most browsers because it is self-signed. To remove this warning message, you must replace the default certificate. See "Managing certificates" (page 376).

Using automated workflows

The controller provides several automated workflows to help perform common configuration tasks. To launch the workflows, select **Automated workflows** on the left side of the main menu bar. The first time you start the controller (and after every factory reset), the workflow home page automatically launches.

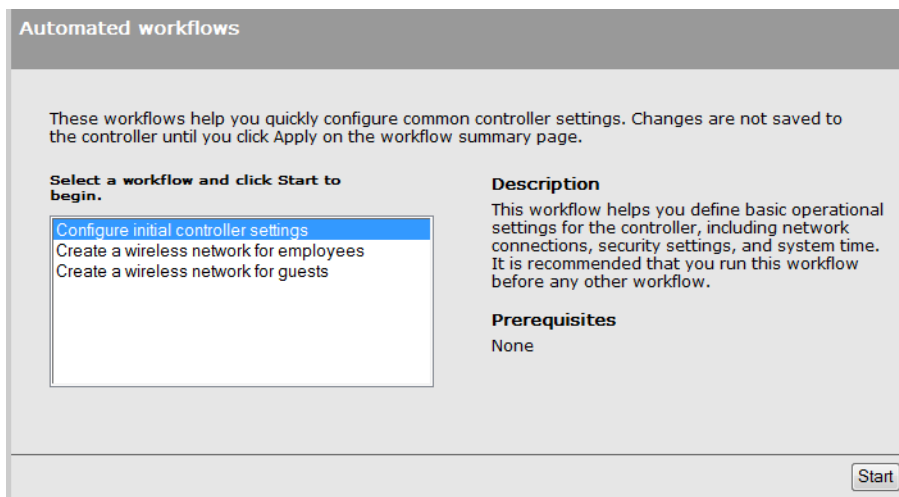

Three workflows are available:

- **Configure initial controller settings:** This workflow helps you to initially configure the controller by defining network connections, security settings, and system time. HP recommends that you run this workflow on factory-default controllers.
- **Create a wireless network for employees:** This workflow helps you create a new wireless network to provide wireless access for employees. It lets you define how employee traffic will be distributed onto your wired infrastructure and configure wireless security settings to safeguard network traffic.
- **Create a wireless network for guests:** This workflow helps you create a new wireless network to provide wireless access for guests. It lets you define how guests will be authenticated (using a RADIUS server or the local user accounts feature on the controller) and how guests will receive an IP address.

Caution: When using teaming and deploying a guest access solution, you must not use the **Create a wireless network for guests** workflow. Instead, you must manually configure guest access as described in the section *“Guest access and teaming”* (page 276).

Each workflow provides instructions and prompts you for options. Read the instructions and respond to the prompts as desired, selecting **Next** to get to subsequent workflow pages. Context-sensitive online help is also available for each workflow page.

The last step in each workflow provides a summary of all configuration settings that will be applied upon final confirmation. For example, the summary page for the **Configure initial controller settings** workflow looks similar to this:

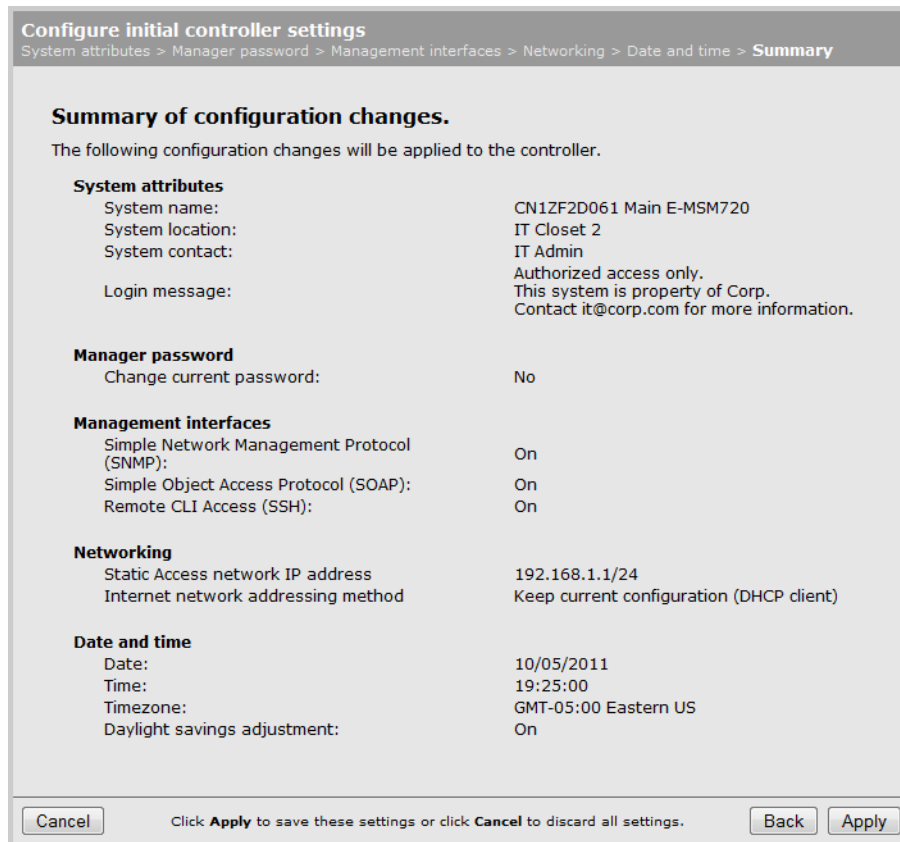

Summary of configuration changes.	
The following configuration changes will be applied to the controller.	
System attributes	
System name:	CN1ZF2D061 Main E-MSM720
System location:	IT Closet 2
System contact:	IT Admin
Login message:	Authorized access only. This system is property of Corp. Contact it@corp.com for more information.
Manager password	
Change current password:	No
Management interfaces	
Simple Network Management Protocol (SNMP):	On
Simple Object Access Protocol (SOAP):	On
Remote CLI Access (SSH):	On
Networking	
Static Access network IP address	192.168.1.1/24
Internet network addressing method	Keep current configuration (DHCP client)
Date and time	
Date:	10/05/2011
Time:	19:25:00
Timezone:	GMT-05:00 Eastern US
Daylight savings adjustment:	On

Cancel Click **Apply** to save these settings or click **Cancel** to discard all settings. Back Apply

Review the settings before you select **Apply** to save and activate your settings on the controller. Alternatively, you can select **Back** to go to the previous workflow page or select **Cancel** to discard your workflow settings and exit the workflow.

After applying your settings, a confirmation page appears showing the menu path to the configuration page for each setting that was changed by the workflow. For example:

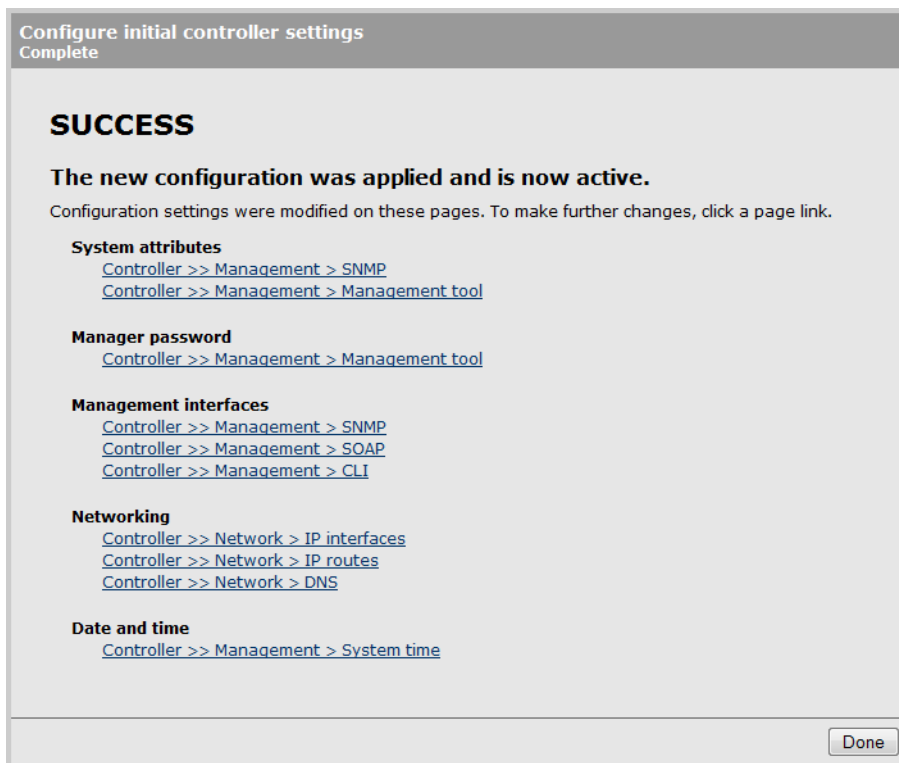

At this point you can:

- Select a page link to make further configuration changes. When done, select **Automated workflows** to return to the confirmation page.
- Select **Done** to return to the Automated workflows home page.



TIP: See also the MSM7xx Controller Installation Guide specific to your controller model for more workflow information.

Setting up manager and operator accounts

Two types of administrative user accounts are defined on the controller: manager and operator.

- The manager account provides full management tool rights.
- The operator account provides read-only rights plus the ability to disconnect wireless clients and perform troubleshooting.

To configure the accounts, select **Controller >> Management > Management tool**.

Management tool configuration

Administrative user authentication ?

Local

RADIUS: <No RADIUS defined>

Security policies ?

Follow FIPS 140-2 guidelines

Follow PCI DSS 1.2 guidelines

Manager account ?

Username:

Current password:

New password:

Confirm new password:

If a manager is logged in, then a new manager login:

Terminates the current manager session

Is blocked until the current manager logs out

Security ?

Access to the management tool is enabled for the addresses and interfaces that are specified below.

Allowed addresses:

IP address: Mask:

Active Interfaces:

Port 1

Wireless port

Operator account ?

Username:

New password:

Confirm new password:

If an operator is logged in, then a new operator login:

Terminates the current operator session

Is blocked until the current operator logs out

Web server ?

Secure web server port:

Web server port:

Login control ?

Lock access after login failures

Lock access for minutes

Auto-Refresh ?

Interval: seconds

Login message ?

Login message:

```
Authorized access only.
This system is property of [COMPANY
NAME].
Contact [EMAIL] for more information.
```

Account inactivity logout ?

Timeout: minutes

Only one administrator (manager or operator) can be logged in at any given time. Options are provided to control what happens when an administrator attempts to log in while another administrator (or the same administrator in a different session) is already logged in. In every case, the manager's rights supersede those of an operator.

The following options can be used to prevent the management tool from being locked by an idle manager or operator:

- **Terminates the current manager session:** When enabled, an active manager or operator session will be terminated by the login of another manager. This prevents the management tool from being locked by an idle session until the **Account inactivity logout** timeout expires.
- **Is blocked until the current manager logs out:** When enabled, access to the management tool is blocked until an existing manager logs out or is automatically logged out due to an idle session.
An operator session is always terminated if a manager logs in. An active operator session cannot block a manager from logging in.
- **Terminates the current operator session:** When enabled, an active operators session will be terminated by the login of another operator. This prevents the management tool from being locked by an idle session until the **Account inactivity logout** timeout expires.
Operator access to the management tool is blocked if a manager is logged in. An active manager session cannot be terminated by the login of an operator.
An operator session is always terminated if a manager logs in. An active operator session cannot block a manager from logging in.
- **Login control:** If login to the management tool fails five times in a row (bad username and/or password), login privileges are blocked for five minutes. Once five minutes expires, login privileges are once again enabled. However, if the next login attempt fails, privileges are again suspended for five minutes. This cycle continues until a valid login occurs. You can configure the number of failures and the timeout.
- **Account inactivity logout:** By default, if a connection to the management tool remains idle for more than ten minutes, the controller automatically terminates the session. You can configure the timeout.

Administrative user authentication

Login credentials can be verified using local account settings and/or an external RADIUS sever. This also affects how many accounts you can have.

- **Local:** Select this option to use a single manager and operator account. Configure the settings for these accounts under **Manager account** and **Operator account**.
- **RADIUS:** Using a RADIUS server enables you to have multiple manager and operator accounts, each with a unique login name and password. To setup this option, see [“Authenticating manager logins using a third-party RADIUS server” \(page 368\)](#).

If both options are enabled, the RADIUS server is always checked first.

Passwords

Passwords must be 6 to 16 printable ASCII characters in length with at least 4 different characters. Passwords are case sensitive. Space characters and double quotes (") cannot be used. Passwords must also conform to the selected security policy as follows.

- **Follow FIPS 140-2 guidelines:** When selected, implements the following requirements from the FIPS 140-2 guidelines:
 - All administrator passwords must be at least six characters long.
 - All administrator passwords must contain at least four different characters.

For more information on these guidelines, refer to the *Federal Information Processing Standards Publication (FIPS PUB) 140-2, Security Requirements for Cryptographic Modules*.

- **Follow PCI DSS 1.2 guidelines:** When selected, implements the following requirements from the PCI DSS 1.2 guidelines:
 - All administrator passwords must be at least seven characters long.
 - All administrator passwords must contain both numeric and alphabetic characters.
 - The settings under **Login control** must be configured as follows:
 - **Lock access after *nn* login failures** must be set to 6 or less.
 - **Lock access for *nn* minutes** must be set to 30 minutes or more.
 - The settings under **Account inactivity logout** must be configured as follows:
 - **Timeout** must be set to 15 minutes or less.

For more information on these guidelines, refer to the Payment Card Industry Data Security Standard v1.2 document.

Manager username/password reset

Not supported on the MSM765 zl and MSM775 zl.

The **Allow password reset via console port** feature provides a secure way to reset the manager login username/password on a controller to factory default values (**admin/admin**), without having to reset the entire controller configuration to its factory default settings. To make use of this feature you must be able to access the controller through its console (serial) port. See [“Console ports” \(page 546\)](#).



IMPORTANT:

- This feature is automatically **enabled** after performing a reset to factory default settings.
- This feature is automatically **disabled** after performing a software (firmware) upgrade from release 5.4x or earlier.



CAUTION: If you disable this feature and then forget the manager username or password, the only way to gain access the management tool is to reset the controller to its factory default settings. See [“Resetting to factory defaults” \(page 547\)](#).

Configuring management tool security

Select **Controller >> Management > Management tool** and configure the settings under **Security**.

On the MSM720

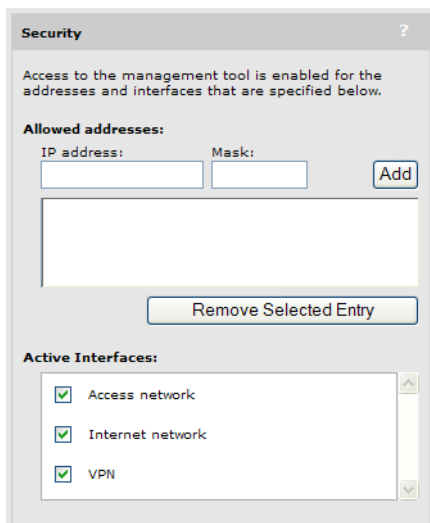

On all other controllers

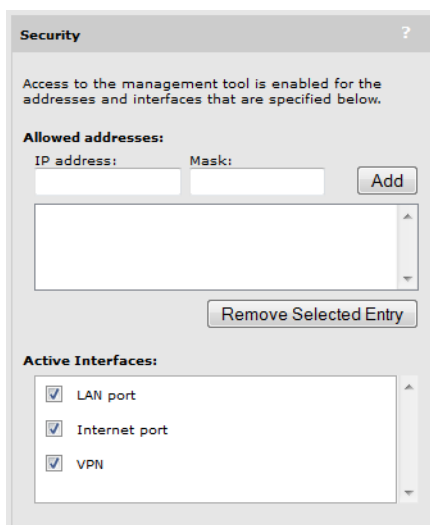

Allowed addresses

Enables you to define a list of IP address from which to permit access to the management tool. To add an entry, specify the IP address and appropriate mask and select **Add**. When the list is empty, access is permitted from any IP address. For example: To allow access for a single computer with IP address 192.168.1.209, specify:

IP address = 192.168.1.209

Mask = 255.255.255.255

To allow access for several computers in the IP address range 192.168.10.16 to 192.168.10.31, specify:

IP address = 192.168.10.16

Mask = 255.255.255.240

Active interfaces

Select the interfaces through which access to the management tool will be permitted. (These settings also apply when SSH is used to access the command line interface.)

Configuring the Login page message

You can customize the message that is displayed at the top of the login page by selecting **Controller >> Management > Management tool** and entering a new message under **Login message**.

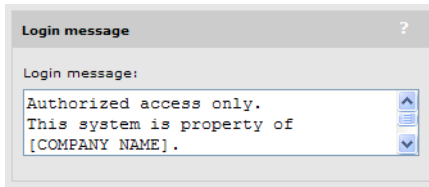

Configuring Auto-refresh

Select **Controller >> Management > Management tool** and configure the settings under **Auto-Refresh**. This option controls how often the controller updates the information in group boxes that show the auto-refresh icon in their title bar. Under **Interval**, specify the number of seconds between refreshes.

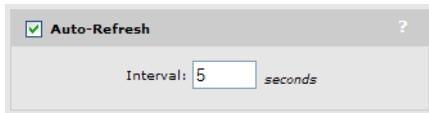

Setting the system time

Select **Controller >> Management > System time** to open the **System time** page. This page enables you to configure the time server and time zone information.

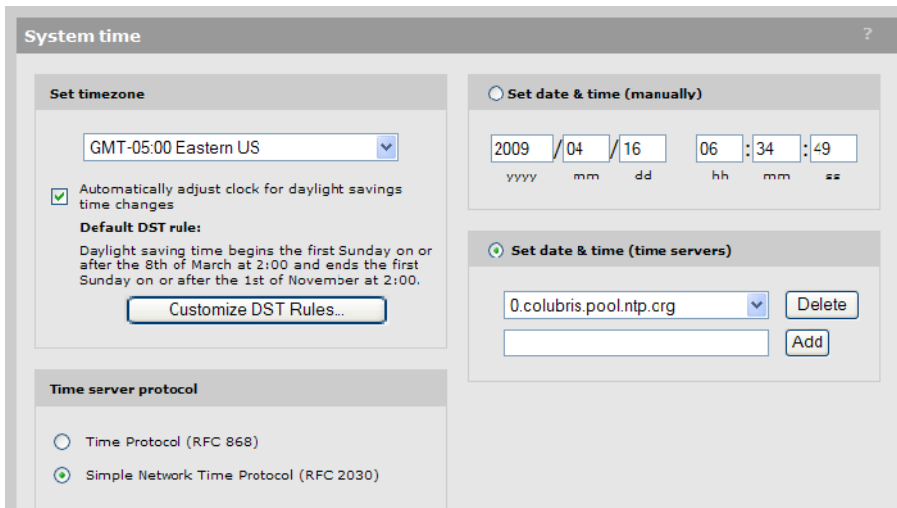

1. Set **timezone & DST** as appropriate.
2. Set **Time server protocol**, to **Simple Network Time Protocol**.
3. Select **Set date & time (time servers)** and then select the desired time server. **Add** other servers if desired. The controller contacts the first server in the list. If the server does not reply, the controller tries the next server and so on. By default, the list contains two ntp vendor zone pools that are reserved for HP networking devices. By using these pools, you will get better service and keep from overloading the standard ntp.org server. For more information visit: www.pool.ntp.org.
4. Select **Save** and verify that the date and time is updated accurately. A working Internet connection on Port 1 is required.

NOTE: If access to the Internet is not available to the controller, you can temporarily set the time manually with the **Set date & time (manually)** option. However, it is important to configure a reliable time server on the controller. Correct time is particularly important when a controller is used. Synchronization and certificate problems can occur if the time is not accurate.

LEDs

On an MSM720 you can select **Controller >> Tools > LEDs** to control operation of the status lights.

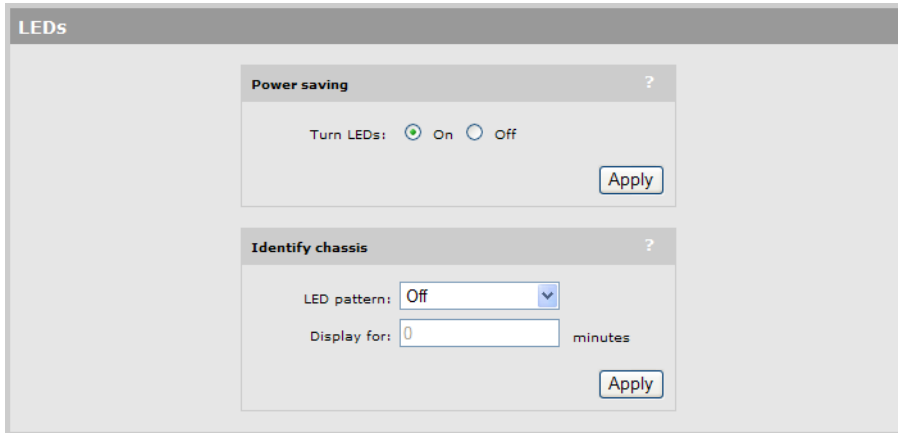

Until fully operational, status lights follow their normal behavior. This allows potential error conditions to be diagnosed.

Power saving

Select the behavior of all LEDs on the chassis LEDs.

- **On:** All LEDs are off.
- **Off:** All LEDs are on.

Identify chassis

Use this feature to help you physically identify a particular controller in your installation.

LED pattern

Select the state of the Locator LED on the front of the MSM720 chassis.

Off: Turn the Locator LED off. Default state.

On: Turn the Locator LED on.

Blinking: Turn the Locator LED on and make it blink.

Display for

Specify how many minutes the On or Blinking LED pattern is active. Once this time expires the LED returns to the Off state.

3 Dashboard

The dashboard provides you with a quick way to view key information about the operation of the wireless network. It uses charts and graphs to display status and statistics, and shows 24-hour history for a number of items.

To view the dashboard, select **Controller >> Dashboard**. For example:

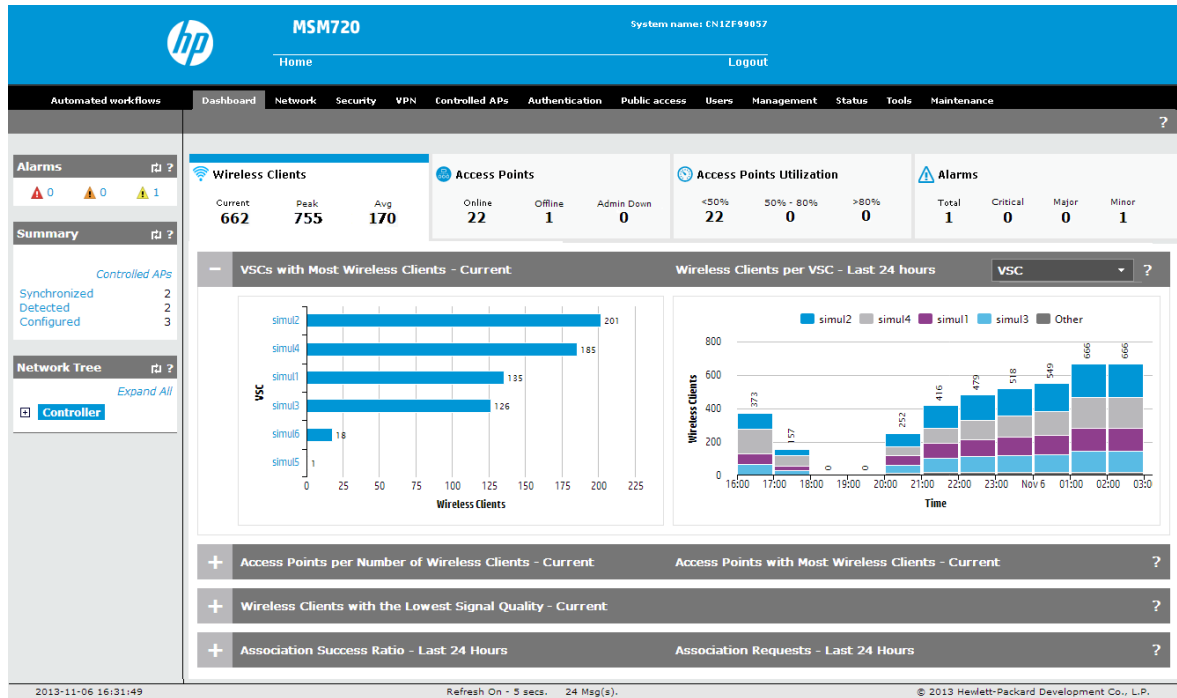

NOTE:

- Unless otherwise specified, data is sampled every minute, and then an average is calculated to be displayed as the hourly value.
- Data is updated at the top of the hour.

Wireless clients

Current

Indicates the total number of wireless clients that are currently connected.

Peak

Indicates the maximum number of wireless clients that were connected during the last 24 hours.

Avg

Indicates the average number of wireless clients that were connected during the last 24 hours.

Access Points

Online

Indicates the number of APs that are able to exchange management information with the controller.

Offline

Indicates the number of APs that have stopped sending management information to the controller. Rediscovery may re-establish the connection. If not, the APs may have lost power or a network failure has occurred. The APs will have a diagnostic value of **Not responding** on the **Controller >> Controlled APs > Discovered APs** page.

APs that are flagged as **Admin Down** do not appear in this count.

Admin Down

Indicates the number of APs that are **Offline** and have been manually set to **Admin Down** (Administratively Down) by an administrator. This state is used to flag an AP that is known to be offline. For example, for maintenance or relocation.

Access Points Utilization

Indicates the number of APs that are able to exchange management information with the controller. Displays the number of APs currently operating in each bandwidth utilization range: <50%, 50% - 80%, >80%.

Only *online* access points with radios that are enabled and operating in access point or local mesh mode are shown on this chart.

The percent utilization is calculated by comparing the total throughput (transmitted/received) of all radios on an AP for the last minute against the maximum throughput that the radios could theoretically achieve.

Alarms

Displays the total number of active alarms for each severity.

Total

Total number of active alarms for all severities.

Critical (Red)

Alarms with this severity indicate a failure and signal the need for immediate attention.

Major (Orange)

Alarms with this severity indicate an impending failure.

Minor (Yellow)

Alarms with this severity indicate a warning condition that can escalate into a more serious problem.

Wireless clients tab

Provides information about the wireless clients connected to all controlled APs. For example:

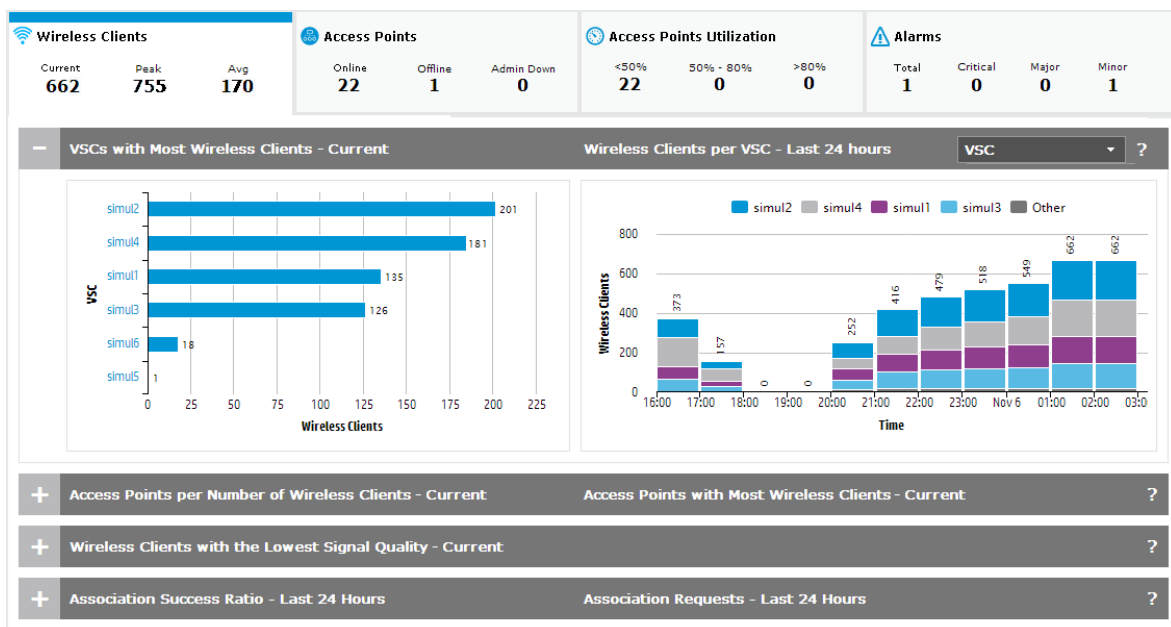

The tab title displays the following information:

- **Current:** Indicates the total number of wireless clients that are currently connected.
- **Peak:** Indicates the maximum number of wireless clients that were connected during the last 24 hours.
- **Avg:** Indicates the average number of wireless clients that were connected during the last 24 hours.

The information shown in the first box depends on the option you select in the drop-down menu on the right side of the title bar. The following options are available: VSC, Band, Wireless Mode, and Signal Quality.

VSC

Select **VSC** to see information about wireless clients connected to VSCs. (This is the default selection.)

VSCs with Most Wireless Clients - Current

Displays the number of wireless clients currently connected to each VSC. Only the ten VSCs with the most connected wireless clients are shown.

Wireless Clients per VSC - Last 24 Hours

Displays the four VSCs with the highest average number of connected wireless clients per hour over the last 24 hours. The entry labeled **Other** displays the average number of connected wireless clients over the last 24 hours for all other VSCs.

Band

Select **Band** to see the number of wireless clients connected to each transmission band.

Wireless Clients per Band - Current

Displays the number of currently connected wireless clients in each band: 5 GHz and 2.4 GHz.

Wireless Clients per Band - Last 24 Hours

Displays the average number of connected wireless clients per hour over the last 24 hours in each band: 5 GHz and 2.4 GHz.

Wireless Mode

Select **Wireless Mode** to see the number of wireless clients connected for each wireless mode.

Wireless Clients per Wireless Mode - Current

Displays the number of currently connected wireless clients for each wireless mode: 802.11ac/n/g/b/a.

Wireless Clients per Wireless Mode - Last 24 Hours

Displays the average number of connected wireless clients per hour over the last 24 hours for each wireless mode: 802.11ac/n/g/b/a.

Note that wireless mode 802.11n includes clients in both the 2.4 GHz and 5 GHz bands.

Signal Quality

Select **Signal Quality** to see the signal-to-noise ratio (SNR) for connected wireless clients.

Wireless Clients per Signal Quality - Current

Displays the number of currently connected wireless clients according to their SNR. The categories are defined as follows:

- **Excellent:** 41 dB and higher
- **Good:** 26 to 40 dB

- **Low:** 16 to 25 dB
- **Very Low:** 15 dB and lower

Wireless Clients per Signal Quality - Last 24 Hours

Displays the average number of connected wireless clients according to their signal quality per hour over the last 24 hours.

Access Points per Number of Wireless Clients - Current

Displays the number of access points that have currently connected wireless clients in one of three ranges: <10, 10 – 50, and >50.

Access points with Most Wireless Clients - Current

Displays the ten access points with the highest number of currently connected wireless clients over the last 24 hours. Select an access point name in the chart for more information.

Wireless Clients with the Lowest Signal Quality - Current

Displays the ten currently connected wireless clients with the lowest SNR value.

Note: If the wireless client name is not known, its MAC address is displayed instead.

Select the name or MAC address to see more detailed information about the client.

Association Success Ratio - Last 24 Hours

Displays the association success ratio during the last 24 hours as a percentage, calculated by comparing successful associations to all attempted associations by wireless clients.

- **Requested:** Total number of wireless association requests during the last 24 hours.
- **Successful:** Total number of successful wireless association requests during the last 24 hours.
- **Failed:** Total number of failed wireless association requests during the last 24 hours.

Association Requests - Last 24 Hours

Displays the number of successful and failed wireless association requests for each hour during the last 24 hours.

Access Points tab

Provides information about all controlled APs. For example:

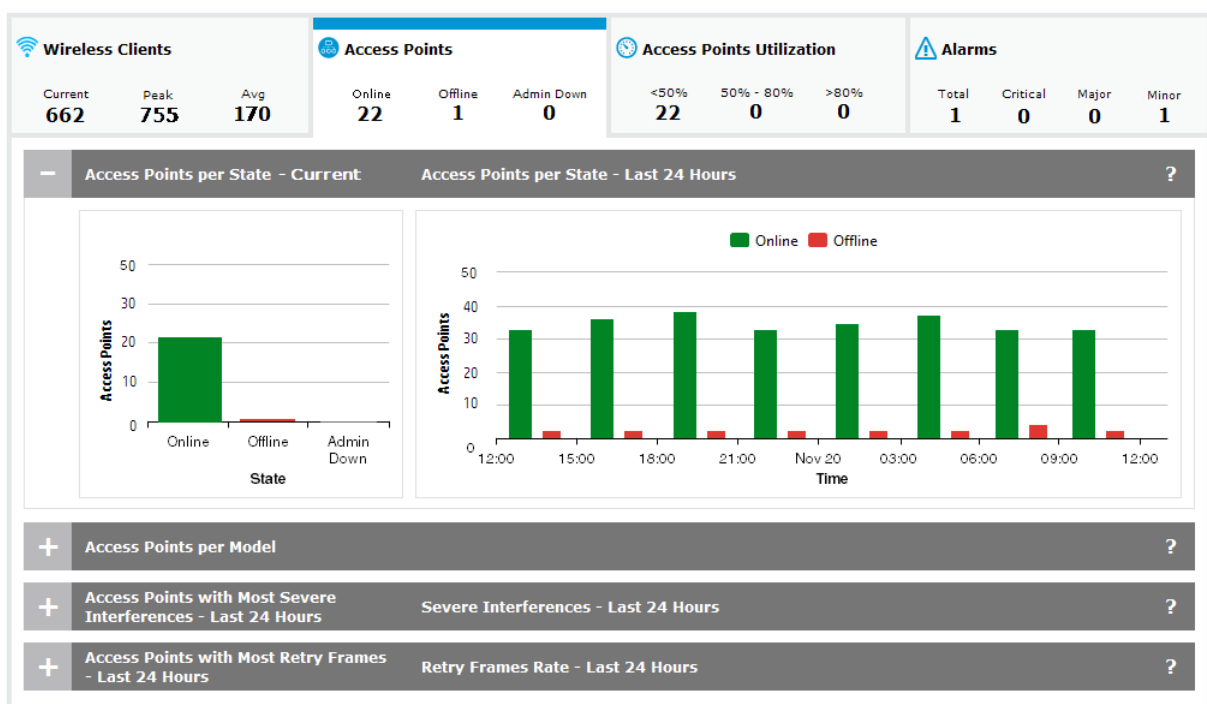

The tab title displays the following information:

- **Online:** Indicates the number of APs that are able to exchange management information with the controller.
- **Offline:** Indicates the number of APs that have stopped sending management information to the controller. Rediscovery may re-establish the connection. If not, the APs may have lost power or a network failure has occurred. The APs will have a diagnostic value of **Not responding** on the **Controller >> Controlled APs > Discovered APs** page. APs that are flagged as **Admin Down** do not appear in this count.
- **Admin Down:** Indicates the number of APs that are **Offline** and have been manually set to **Admin Down** (Administratively Down) by an administrator. This state is used to flag an AP that is known to be offline. For example, for maintenance or relocation.

Access Points per State - Current

Displays the number of access points that are currently in each of the following states: Online, Offline, Admin Down.

Access Points per State - Last 24 Hours

Displays the number of APs that have been online or offline for each hour during the last 24 hours. To be counted as online, an AP must be online for at least 30 minutes of an hour.

Access Points per Model

Displays the number of access points of each model.

Access Points with Most Severe Interferences - Last 24 Hours

Displays the ten access points that detected the most instances of severe interference over the last 24 hours.

Severe Interferences - Last 24 Hours

Displays the number of severe interferences detected by all access points for each hour during the last 24 hours.

Access Points with Most Retry Frames - Last 24 Hours

Displays the ten access points that executed the most retry frames (single and multiple) over the last 24 hours.

Retry Frames Rate - Last 24 Hours

Displays the total number of single and multiple retry frames for all access points for each hour during the last 24 hours.

- **Single retry:** Displays the number of MSDUs successfully transmitted after one (and only one) retransmission (on the total of all associated fragments). This may be due to collisions, noise, or interference. Large numbers of single retries can indicate that too many computers are using the wireless network or that something is interfering with transmissions.
- **Multiple retries:** Displays the number of MSDUs successfully transmitted after more than one retransmission (on the total of all associated fragments). This may be due to collisions, noise, or interference. Excessive retries can indicate that too many computers are using the wireless network or that something is interfering with transmissions.

Access Points Utilization tab

Provides information about the utilization of controlled APs. For example:

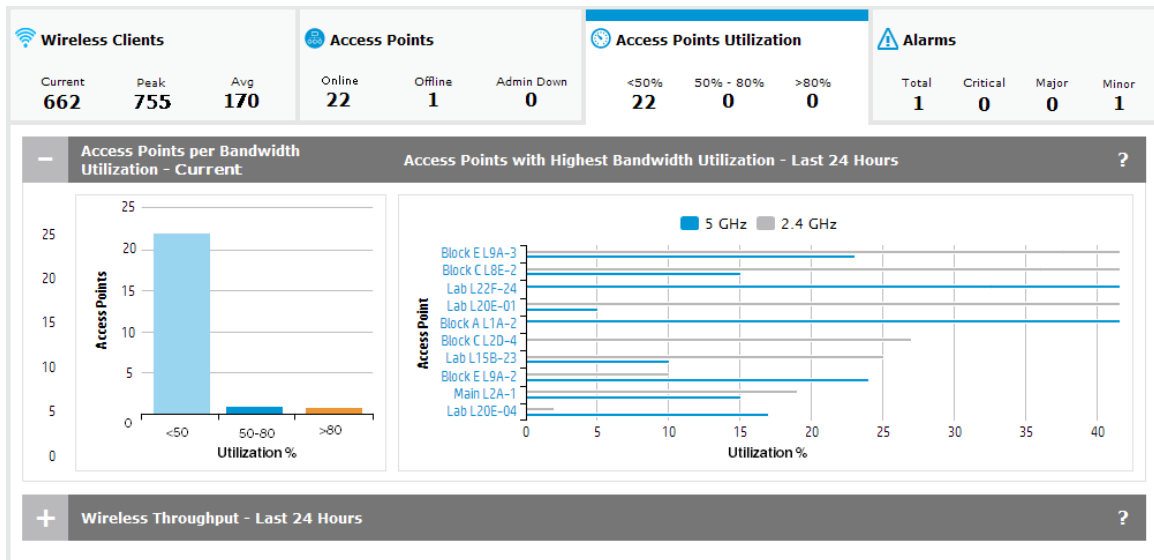

The tab title displays the number of APs currently operating in each bandwidth utilization range: <50%, 50% - 80%, >80%.

Only *online* access points with radios that are enabled and operating in *access point* and/or *local mesh* mode are shown on this chart.

The percent utilization is calculated by comparing the total throughput (transmitted/received) of all radios on an AP for the last minute against the maximum throughput that the radios could theoretically achieve.

Access Points per Bandwidth Utilization - Current

Displays the number of APs that are operating in each bandwidth utilization range: <50%, 50% - 80%, >80%.

Access Points with Highest Bandwidth Utilization - Last 24 Hours

Displays the ten access points with the highest bandwidth utilization percentage over the last 24 hours. If an AP has more than one radio, a separate bar is shown for each radio.

Wireless Throughput - Last 24 Hours

Displays the total wireless throughput in bits per second (bps) for all APs for each hour during the last 24 hours.

- **Tx:** Traffic sent by the APs.
- **Rx:** Traffic received by the APs.

Most Active Wireless Clients - Last 24 Hours

Displays the ten most active wireless clients during the last 24 hours based on the total amount of traffic (in bytes) sent and received.

If the name of the wireless client is not known, then its MAC address is displayed.

Hover your mouse pointer over the name to display the total time that the client has been connected and its average throughput.

Alarms tab

Displays the total number of active alarms for each severity. For example:

Wireless Clients			Access Points			Access Points Utilization			Alarms			
Current	Peak	Avg	Online	Offline	Admin Down	<50%	50% - 80%	>80%	Total	Critical	Major	Minor
662	755	170	22	1	0	22	0	0	10	1	4	5

Most Recent Alarms (6)		Acknowledge All Recent ?	
-	AP incompatible settings AP K098-00095 could not be updated with the current configuration.	2 hours ago	
	Probable Cause: Local mesh has been provisioned on the AP but either the AP's radio is disabled, the AP radio operating mode does not support local mesh, the APs radio wireless mode does not match the one provisioned or the mesh ID is not uniquely assigned.		
	Recommended Action: Verify the AP's configuration settings and adjust conflicting parameters.		Acknowledge Details
+	AP not authorized AP K098-00095 could not be authenticated by the controller.	6 minutes ago	
+	AP unconfigurable AP K098-00095 cannot be added to the controller.	61 minutes ago	

Alarms - Last 24 Hours		?

The tab title displays the following information:

- **Total:** Total number of active alarms for all severities.
- **Critical (Red):** Alarms of this severity indicate a failure and signal the need for immediate attention.
- **Major (Orange):** Alarms of this severity indicate an impending failure.
- **Minor (Yellow):** Alarms of this severity indicate a warning condition that can escalate into a more serious problem.

Most Recent Alarms

Displays the ten most recent active alarms.

Select **Acknowledge All Recent** to acknowledge all alarms shown on this page.

Select the + symbol to see the following for each alarm:

- **Probable Cause:** Condition that most likely caused the alarm.
- **Recommended Action:** The action that should be taken to clear the alarm.
- **Acknowledge:** Select this button to acknowledge the alarm.
- **Details:** Select this button to see more information on the alarm.

Alarms - Last 24 Hours

Displays the number of alarms, categorized by severity, for each hour during the last 24 hours. An alarm must be active for at least 30 minutes during an hour to be counted. (Note: This is not a count of alarms raised during an hour, but alarms that are active.)

4 Network configuration

Working with network profiles

The controller uses logical entities called network profiles to manage the configuration of network settings. Network profiles let you define the characteristics of a network and assign a friendly name and VLAN to it. Once defined, network profiles can then be assigned to a port or a trunk (MSM720 only) as required. Network profiles make it easy to use the same settings in multiple places on the controller.

For example, if you define a network profile with a VLAN ID of 10, you could use that profile to:

- Map VLAN 10 to a controller port using the **Controller >> Network > VLANs** page.
- Set VLAN 10 as the egress network for a group of APs when binding them to a VSC using the **Controlled APs > [group] >> VSC bindings** page.
- Set VLAN 10 as the local network for an AP using the **Controlled APs >> Configuration > Local network** page.
- Map VLAN 10 to a trunk as either tagged or untagged using the **Controller >> Network > VLANs** page.

About the default network profiles

Two network profiles are created by default. The names assigned to these profiles are different depending on the product you are configuring.

On the MSM720

The two profiles are named **Access network** and **Internet network**. You can edit these profiles, but you cannot delete them. By default, they are configured as follows:

- **Access network:** Assigned to VLAN 1 and is mapped to ports 1, 2, 3, 4, untagged. (On an untagged port, the VLAN is only used internally to route/switch traffic.) The Access network profile can only be configured with a static IP address. By default, this address is 192.168.1.1.
- **Internet network:** Assigned to VLAN 10 and is mapped to ports 5 and 6, untagged. To see the mapping, consult the VLANs page. (On an untagged port, the VLAN is only used internally to route/switch traffic.) By default, this profile is configured to operate as a DHCP client to automatically obtain an address from a DHCP server.

To see the mappings, consult the **Controller >> Network > VLANs** page.

On all other controllers

The two profiles are named **LAN port network** and **Internet port network**. These profiles are associated with the two physical Ethernet ports (LAN port and Internet port) on the controller. You can rename these profiles, but you cannot assign a VLAN to them or delete them.



- **LAN port:** Mapped to the LAN port. This profile can only be configured with a static IP address. By default, it is set to 192.168.1.1.
- **Internet port:** Mapped to the Internet port. By default, this profile is configured to operate as a DHCP client to automatically obtain an address from a DHCP server.

To see the mappings, consult the **Controller >> Network > VLANs** page.

To define a new network profile



1. Select **Controller >> Network > Network profiles**.

On the MSM720

Network profiles		
Name	VLAN ID	Delete
Access network	1	
Internet network	10	

[Add New Profile...](#)

On all other controllers

Network profiles		
Name	VLAN ID	Delete
Internet port network	N/A	
LAN port network	N/A	

[Add New Profile...](#)

2. Select **Add New Profile**.

Add/Edit network profile

Settings

Name:

VLAN ID:

[Cancel](#) [Save](#)

3. Configure profile settings as follows:
 - Under **Settings**, specify a **Name** for the profile.
 - To assign a VLAN, select **VLAN ID** and then specify a number.

If needed, you can also define a range of VLANs. This enables a single VLAN definition to span a large number of contiguously assigned VLANs. Specify the range in the form X-Y, where X and Y can be 1 to 4094. For example: 50-60.

An IP address cannot be assigned to a VLAN range.



You can define more than one VLAN range by using multiple profiles. Each range must be distinct and contiguous.

4. Select **Save**.

Configuring IP interfaces

The IP interfaces page lists all network profiles to which an IPv4 address is assigned. To open the IP interfaces page, select **Controller >> Network > IP interfaces**.

On the MSM720

IPv4 interfaces				
Interface	IP address	Mask	Allocation method	Delete
Access network	192.168.1.1	255.255.255.0	STATIC	
Internet network	15.226.15.87	255.255.255.128	DHCP	

[Add New Interface...](#)

On all other controllers

Interface	IP address	Mask	Allocation method	Delete
Internet port	10.212.50.6	255.255.0.0	DHCP	
LAN port	192.168.1.1	255.255.255.0	STATIC	

[Add New Interface...](#)

The following interfaces are created by default. They can be edited, but not deleted.

On the MSM720

- **Access network** is assigned to VLAN 1 and is mapped to ports 1, 2, 3, and 4, untagged. (On an untagged port, the VLAN is only used internally to route/switch traffic.)
- **Internet network** is assigned to VLAN 10 and is mapped to ports 5 and 6, untagged. (On an untagged port, the VLAN is only used internally to route/switch traffic.)

On all other controllers

- **LAN port** is assigned to the LAN port untagged.
- **Internet port** is assigned to the Internet port untagged.

To assign an IP address to a new interface on the MSM720

Any network profile that has a VLAN ID and is mapped to a physical port can have an IP address assigned to it. The following steps illustrate how to create a new profile and assign an IP address to it.

1. Select **Controller >> Network > Network profiles**.
2. Select **Add New Profile**.
3. Specify a name for the profile and assign a VLAN ID to it. This example uses the profile name **Network A** and a VLAN ID of **25**. Select **Save**.

Add/Edit network profile

Settings

Name:

VLAN ID:

4. Select **Controller >> Network > VLANs** to open the VLANs page.

Network profile	VLAN ID	Location	Tagged	Untagged
<input type="checkbox"/> Access network (Default)	1	Local		1, 2, 3, 4
<input type="checkbox"/> Internet network	10	Local		5, 6
<input type="checkbox"/> Network A	25	None		

- Select the new profile in the table to open the Add/Edit VLAN mapping page.

- Select the port to which you want to map the profile (in this case port 4). Next, select **Untagged** for **Mode**, then select **Apply**.

- Select **Save**. The profile is mapped to the port 4 untagged.

Network profile	VLAN ID	Location	Tagged	Untagged
Access network (Default)	1	Local		1, 2, 3
Internet network	10	Local		5, 6
Network A	25	Local		4

- Select **Controller >> Network > IP interfaces** to open the IPv4 interfaces page.

IPv4 interfaces				
Interface	IP address	Mask	Allocation method	Delete
Access network	192.168.1.1	255.255.255.0	STATIC	
Internet network	192.168.5.73	255.255.255.0	STATIC	

[Add New Interface...](#)

9. Select **Add New Interface** to open the Add/Edit interface page.

Add/Edit interface

Interface

Network A (25)

Assign IP address via

DHCP client

Static

IP address:

Mask:

Gateway:

Network address translation (NAT)

Enabled Disabled

[Cancel](#) [Save](#)

10. Under **Interface**, select the network profile that you defined earlier.
11. Under **Assign IP address via**, select the addressing method to use.
 - **DHCP client:** Dynamic host configuration protocol. The DHCP server will automatically assign an address to the network profile, which functions as a DHCP client.
 - **Static:** Specify an **IP address**, **Mask**, and **Gateway**.
12. Enable/disable NAT support if required.
13. Select **Save**. The new interface is added to the IPv4 interfaces table.

IPv4 interfaces				
Interface	IP address	Mask	Allocation method	Delete
Access network	192.168.1.1	255.255.255.0	STATIC	
Internet network	192.168.5.73	255.255.255.0	STATIC	
Network A (25)	0.0.0.0	0.0.0.0	DHCP	

[Add New Interface...](#)

To assign an IP address to a new interface on other controllers

Any network profile that has a VLAN ID and is mapped to a physical port can have an IP address assigned to it. The following steps illustrate how to create a new profile and assign an IP address to it.

1. Select **Controller >> Network > Network profiles**.
2. Select **Add New Profile**.

- Specify a name for the profile and assign a VLAN ID to it. This example uses the profile name **Network A** and a VLAN ID of **25**. Select **Save**.

Add/Edit network profile

Settings

Name:

VLAN ID:

- Select **Controller >> Network > VLANs** to open the VLANs page.

VLANs

Number of matching VLANs: 3 [Show all VLANs](#)

Filter VLANs by: Network profile

Select the action to apply to the selected network profiles: -- Select an Action --

<input type="checkbox"/>	Network profile	VLAN ID	Location	Tagged	Untagged
<input type="checkbox"/>	Internet port network	N/A	Local		Internet port
<input type="checkbox"/>	LAN port network	N/A	Local		LAN port
<input checked="" type="checkbox"/>	Network A	25	None		

- Select the new profile in the table to open the Add/Edit VLAN mapping page.

Add/Edit VLAN mapping

Selected network profiles

Network profile	VLAN ID
Network A	25

Map to

Port:

- Select the port to which you want to map the profile (in this case the **LAN port**).
- Select **Save**. The profile is mapped to the LAN port tagged.

VLANs

Number of matching VLANs: 3 [Show all VLANs](#)

Filter VLANs by: Network profile

Select the action to apply to the selected network profiles: -- Select an Action --

<input type="checkbox"/>	Network profile	VLAN ID	Location	Tagged	Untagged
<input type="checkbox"/>	Internet port network	N/A	Local		Internet port
<input type="checkbox"/>	LAN port network	N/A	Local		LAN port
<input checked="" type="checkbox"/>	Network A	25	Local	LAN port	

- Select **Controller >> Network > IP interfaces** to open the IPv4 interfaces page.

IPv4 interfaces				
Interface	IP address	Mask	Allocation method	Delete
Internet port	192.168.5.72	255.255.255.0	STATIC	
LAN port	192.168.1.1	255.255.255.0	STATIC	

[Add New Interface...](#)

9. Select **Add New Interface** to open the Add/Edit interface page.

Add/Edit interface

Interface

Network A (25) ▼

Assign IP address via

DHCP client

Static

IP address:

Mask:

Gateway:

Network address translation (NAT)

Enabled Disabled

[Cancel](#) [Save](#)

10. Under **Interface**, select the network profile that you defined earlier.
11. Under **Assign IP address via**, select the addressing method to use.
 - **DHCP client:** Dynamic host configuration protocol. The DHCP server will automatically assign an address to the network profile, which functions as a DHCP client.
 - **Static:** Specify an **IP address**, **Mask**, and **Gateway**.
12. Enable/disable NAT support if required.
13. Select **Save**. The new interface is added to the IPv4 interfaces table.

IPv4 interfaces				
Interface	IP address	Mask	Allocation method	Delete
Internet port	192.168.5.72	255.255.255.0	STATIC	
LAN port	192.168.1.1	255.255.255.0	STATIC	
Network A (25)	0.0.0.0	0.0.0.0	DHCP	

[Add New Interface...](#)

Configuring the Access network/LAN port interface

The following configuration options are available if you select the Access network interface (on an MSM720) or LAN port interface (on all other controllers) in the table.

The image shows a dialog box titled "Access network configuration". It contains two sections: "Addressing" and "Management address".

Addressing section:

- IP address: 192.168.1.1
- Mask: 255.255.255.0

Management address section:

- IP address: [empty text box]
- Mask: [empty text box]

At the bottom of the dialog are "Cancel" and "Save" buttons.

Addressing

The Access network/LAN port interface must be configured with a static IP address. By default, it is set to the address 192.168.1.1.

Management address

Use this option to assign a second IP address to the Access network/LAN port interface. This address provides a simple way to separate management traffic from user traffic without using VLANs.

For example, by default the Access network/LAN port interface is set to 192.168.1.1 and all client devices obtain an address on this subnet from the controller DHCP server. With this feature you can add another address, say 192.168.2.1/255.255.255.0. APs can then be assigned to this subnet using static IP addressing. Now all management traffic exchanged between the controller and the APs is on a separate subnet.

Configuring the Internet network/Internet port interface

The following configuration options are available if you select the Internet network interface (on an MSM720) or Internet port interface (on all other controllers) in the table.

The image shows a dialog box titled "Internet network configuration". It contains two sections: "Assign IP address via" and "Network address translation (NAT)".

Assign IP address via section:

- PPPoE Client [Configure...]
- DHCP Client [Configure...]
- Static [Configure...]
- No address (Support VLAN traffic only)

Network address translation (NAT) section:

- Network address translation (NAT)
- Limit NAT port range
- Size of port range: 50

At the bottom of the dialog are "Cancel" and "Save" buttons.

By default, the Internet port operates as a DHCP client (except on the MSM765 z1 and MSM775 z1, where it must be manually configured). Select the option you want to use and select **Configure**. See the following sections for additional configuration information.

- “Configuring the PPPoE client” (page 40)
- “Configuring the DHCP client” (page 41) (default setting)
- “Static addressing” (page 42)

Network address translation

Enable this option to permit all the computers on the network to simultaneously share the connection on the Internet port. See “Network address translation” (page 62).

Limit NAT port range

When enabled, the controller reserves a range of TCP and UDP ports for each authenticated, access-controlled user starting at port 5000, and maps all outgoing traffic for the user within the range.

NOTE: If you enable this feature you should not assign static NAT mappings in the range 5000 to 10000.

Size of port range

Sets the number of TCP and UDP ports reserved for each user.

Configuring the PPPoE client

Internet port - PPPoE client configuration

Settings	Assigned by PPPoE server
Username: <input type="text"/>	Service provider:
Password: <input type="text"/>	Connection status:
Confirm password: <input type="text"/>	IP address: 0.0.0.0
Maximum Receive Unit (MRU): <input type="text" value="1492"/>	Mask: 0.0.0.0
Maximum Transmit Unit (MTU): <input type="text" value="1492"/>	Primary DNS address: 0.0.0.0
<input checked="" type="checkbox"/> Auto-reconnect	Secondary DNS address: 0.0.0.0
<input type="checkbox"/> Un-numbered mode	Default gateway: 0.0.0.0
	<input type="button" value="Restart Connection"/>
<input type="button" value="Cancel"/>	<input type="button" value="Save"/>

- Under **Settings**, define the following:
 - Username:** Specify the username assigned to you by your ISP. The controller will use this username to log on to your ISP when establishing a PPPoE connection.
 - Password/Confirm password:** Specify the password assigned to you by your ISP. The controller will use this password to log on to your ISP when establishing a PPPoE connection.
 - Maximum Receive Unit (MRU):** Maximum size (in bytes) of a PPPoE packet when receiving. Changes to this parameter only should be made according to the recommendations of your ISP. Incorrectly setting this parameter can reduce the throughput of your Internet connection.
 - Maximum Transmit Unit (MTU):** Maximum size (in bytes) of a PPPoE packet when transmitting. Changes to this parameter should only be made according to the recommendations of your ISP. Incorrectly setting this parameter can reduce the throughput of your Internet connection.
 - Auto-reconnect:** The controller will automatically attempt to reconnect if the connection is lost.
 - Un-numbered mode:** This feature is useful when the controller is connected to the Internet and NAT is not being used. Instead of assigning two IP addresses to the controller, one to the Internet port and one to the LAN port, both ports can share a single IP address.
This is especially useful when a limited number of IP addresses are available to you.
- Under **Assigned by PPPoE server**, select **Restart Connection**. Once you are connected to the server, the following fields will display information about your connection. The Internet connection is not active until this occurs. Refer to the online help for a description of each field.

Configuring the DHCP client

The screenshot shows a configuration window for the DHCP client. It has a title bar 'Internet port - DHCP client configuration'. The window is split into two panes. The left pane, titled 'Settings', contains a text box for 'DHCP Client ID' with the value 'R007-00001' and a '(optional)' label. The right pane, titled 'Assigned by DHCP server', shows the following information: 'Domain name:', 'IP address: 192.168.5.76', 'Mask: 255.255.255.0', 'Primary DNS address:', 'Secondary DNS address:', 'Default gateway:', and 'Expiration time:'. At the bottom of the right pane are 'Release' and 'Renew' buttons. At the bottom of the entire window are 'Cancel' and 'Save' buttons.

The DHCP client does not require any configuration, unless you need to set a value for the optional **DHCP Client ID** parameter for proper operation with your DHCP server.

Once you are connected to the server, the fields under **Assigned by DHCP server** show the settings assigned to the controller by the DHCP server. The connection is not active until this occurs. Refer to the online help for a description of each field.

If you want to force the DHCP client to obtain a new lease, select **Release** and then **Renew**.

Static addressing

Internet port - Static IP address configuration

Port settings

IP address: 192.168.5.76

Address mask: 255.255.255.0

Additional IP addresses

Type of addresses: VPN one-to-one NAT

Address pool

None entered

Remove

IP address or range: Add

Cancel Save

Under **Port settings**, define the following:

- **IP address:** Specify the static IP address you want to assign to the port.
- **Address mask:** Specify the appropriate mask for the IP address you specified.
- **Default gateway:** Specify the address of the default gateway on the network.

Additional IP addresses

You need to configure these settings if you are making use of the VPN one-to-one NAT feature or the public IP address feature. For more information see:

- [“VPN one-to-one NAT” \(page 515\)](#)
- [“Assigning public IP addresses” \(page 47\)](#)

Configuring port settings

To configure settings for the physical ports on the controller, select **Controller >> Network > Ports**.

On the MSM720

Name	Duplex	Speed	Trunk type	Trunk group	MAC address
Port 1			None		78:e3:b5:8e:c0:a2
Port 2			None		78:e3:b5:8e:c0:a3
Port 3			None		78:e3:b5:8e:c0:a4
Port 4			None		78:e3:b5:8e:c0:a5
Port 5	Full	1 Gbps	None		78:e3:b5:8e:c0:a6
Port 6			None		78:e3:b5:8e:c0:a7

On all other controllers

Jack	Name	Duplex	Speed	MAC address
	Internet port	Full	1 Gbps	00:1b:3f:87:43:f8
	LAN port	Full	1 Gbps	00:1b:3f:87:43:f9

Status light

- **Green:** Port is properly configured and ready to send and receive data.
- **Red:** Port is not properly configured or is disabled.

Jack

Supported on the MSM765 zl and MSM775 zl only.

Indicates the jack (physical interface) to which a port is assigned.

Name

Identifies the port.

Duplex

Not supported on the MSM765 zl and MSM775 zl.

Indicates if the port is Full or Half duplex.

Speed

Not supported on the MSM765 zl and MSM775 zl.

Indicates the speed at which the port is operating.

Trunk type

Only supported on the MSM720.

Indicates the type of trunk to which the port is assigned:

- **None:** The port is not assigned to a trunk.
- **Trunk:** The port is assigned to a static trunk.
- **LACP:** The port is assigned to a dynamic trunk that uses LACP (active mode).

Trunk group

Only supported on the MSM720.

Indicates the trunk group to which a port is assigned.

- **Trunk n:** The port is assigned to a static trunk, with n indicating the trunk number (1 to 6).
- **Dyn n:** The port is assigned to a dynamic trunk (LACP), with n indicating the trunk number (1 to 6). A separate LACP trunk is automatically created for each LACP-enabled switch to which the MSM720 is connected. For example, if you connect ports 1 and 2 to switch 1, and ports 3 and 4 to switch 2, then the controller automatically creates the groups Dyn 1 and Dyn 2.

MAC address

Indicates the MAC address of the port.

Configuring MSM720 ports

All MSM720 ports have the same configuration settings, for example, Port 1:

The screenshot shows a configuration window for 'Port 1'. It is divided into two main sections: 'Trunk settings' and 'Link settings'.
- **Trunk settings:** 'Type' is a dropdown menu set to 'None'. 'Group' is a dropdown menu set to 'Trunk 1'.
- **Link settings:** 'Speed' is a dropdown menu set to 'Auto'. 'Duplex' is a dropdown menu set to 'Auto'. Below these, it indicates '(Currently: Down)'.
At the bottom of the window, there are two buttons: 'Cancel' on the left and 'Save' on the right.

Trunk settings

Use these settings to map the port to a trunk group. For more information on trunking, see “Port trunking” (page 70).

- Type**
- None: The port is not assigned to a trunk group.
 - LACP: The port is assigned to a dynamic trunk that uses LACP.
 - Trunk: The port is assigned to a static trunk group.

Group If **Type** is set to **Trunk**, select the trunk group to which the port will be assigned.

Link settings

By default, the controller automatically adjusts link settings based on the type of equipment the port is connected to. If needed, you can force the port to operate at a particular speed or duplex setting.

Configuring the LAN/Internet port on the MSM760

Configuration settings for the LAN port and Internet port are identical, for example:

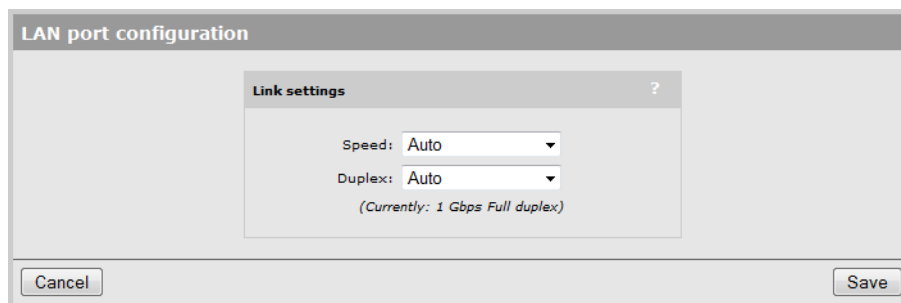

Link settings

By default, the controller automatically adjusts link settings based on the type of equipment the port is connected to. If needed, you can force the port to operate at a particular speed or duplex setting.

Configuring the LAN/Internet port on the MSM765 zl and MSM775 zl

Configuration settings for the LAN port and Internet port are made using the command line interface (CLI) on the MSM765 zl and MSM775 zl. See the *HP MSM765 zl Mobility Controller Installation Guide* and the *HP MSM775 zl Controller Installation Guide* for complete instructions.

Link settings

By default, the controller automatically adjusts link settings based on the type of equipment the port is connected to. If needed, you can force the port to operate at a particular speed or duplex setting.

Configuring DHCP services

The controller can operate as a DHCP server or DHCP relay agent on the LAN port (Access network on the MSM720). This enables it to assign IP addresses to downstream devices connected to the LAN port.

By default, address allocation is disabled. To configure address allocation settings, select **Controller >> Network > Address allocation**.



For information on VPN address pool, see [“Configure an IPSec profile for wireless client VPN” \(page 509\)](#).

Configuring the global DHCP server

The global DHCP server can be used to automatically assign IP addresses to devices that are connected to the controller via the LAN port or through the client data tunnel. If you do not have a DHCP server operating on your network, you can use the global DHCP server to assign addresses to your wired clients, wireless clients, and controlled APs.

For added flexibility, separate DHCP servers can be enabled on any access-controlled VSC, enabling different address ranges to be served. For details, see [“DHCP server” \(page 134\)](#).

NOTE:

- Do not enable the DHCP server if the LAN port (Access network on the MSM720) is connected to a network that already has an operational DHCP server.
- The global DHCP server settings are always used by the default VSC.
- The DHCP server feature is not supported when controller teaming is active.

To configure the global DHCP server

1. Select **Controller >> Network > Address allocation**.



2. Select **DHCP server** and then **Configure**.

3. Under **Addresses**, define the following:

- **Start / End:** Specify the starting and ending IP addresses that define the range of addresses the DHCP server can assign to client stations. The address assigned to the controller is automatically excluded from the range.
- **Gateway:** Specify the IP address of the default gateway the controller will assign to DHCP users. In most cases you will specify the IP address of the controller LAN port as the **Gateway**.
- **DNS servers to assign to client stations:** This is always the IP address of the LAN port.

4. Under **Settings**, define the following:

- **Domain name:** Specify the domain name the controller will return to DHCP users. Typically, this will be your corporate domain name.

The host name in the currently installed SSL certificate is automatically assigned as the domain name of the controller. The factory default SSL certificate that is installed on the controller has the host name **wireless.hp.internal**.

You do not have to add this name to your server for it to be resolved. The controller intercepts all DNS requests it receives. It resolves any request that matches the certificate host name by returning the IP address assigned to the Internet port. All other DNS requests are forwarded to the appropriate DNS servers as configured on the **Controller >> Network > DNS** page.

To summarize, this means that by default, any DNS request by a user that matches **wireless.hp.internal** will return the IP address of the LAN port (Access network on the MSM720).

- **Lease time:** Specify the lease time (in seconds) that the controller will assign to all assigned addresses. As long as a user remains connected, their address is automatically renewed when the lease time expires. If a user disconnects without releasing their address, then the address remains reserved until the lease time expires. If you have a small address pool and a large user turnover, setting a long lease time may cause you to run out of addresses even though they are not really in use.

- **Logout HTML user on discovery request:** When enabled, the controller will log out a client station if a DHCP discovery request is received from the client station while a DHCP address lease is currently assigned.
This feature is useful when multiple users share the same client station. If a user forgets to log out before turning off the client station, the next user will have to wait until the lease expires before being able to log in.
- **Listen for DHCP requests on:** Select the port on which the controller will listen for DHCP requests from client stations.
 - **LAN port (Access network on the MSM720):** Listen for requests on the LAN port (Access network on the MSM720).
 - **Client data tunnel:** Enable this option when the client data tunnel feature is active on one or more VSCs, and you want tunneled client stations to be able to receive an IP address from the controllers DHCP server.

5. Select **Save**.

Assigning fixed DHCP leases

Use this feature to permanently reserve an IP addresses lease for a specific device. This ensures that the device is always reachable at the same address on the network, but does not require a static address to be set directly on the device itself. This table lists all permanently reserved addresses. Up to 255 fixed leases can be defined.

Active fixed leases			
Mac Address	Ip Address	Unique identifier	Delete
00:03:52:08:02:32	192.168.45.30	00:03:52:08:02:32	
<input type="text" value="00:03:52:08:03:14"/>	<input type="text" value="192.168.45.31"/>	<input type="text" value="00:03:52:08:03:14"/>	<input type="button" value="Add"/>

To assign a specific IP address to a client station, specify the following and select **Add**:

- **MAC address:** MAC address of the client station in the format: nn:nn:nn:nn:nn:nn.
- **IP address:** IP address that will be assigned to the client station in the format: nnn.nnn.nnn.nnn.
- **Unique identifier:** A number that identifies the device. Must be unique to all DHCP clients on the network. Generally set to the MAC address of the client station. This parameter is optional unless MAC masquerading is being performed by the client station.

Assigning public IP addresses

This feature enables the integrated DHCP server on the controller to assign public IP addresses to users. A user with a public IP address is visible on the protected network connected to the Internet port, instead of being hidden by the controllers NAT feature. This makes it possible for external devices to create connections with a computer on the internal network.

Public IP addresses are assigned by the integrated DHCP server using the addresses specified in the **Address pool**. Whenever possible, this feature will assign the same public IP address to a user each time they connect.

When you enable public IP address support in a subscription plan, an additional setting is available called **Reserve public IP address**. When this option is enabled, the public IP assigned to a user is reserved until their subscription plan expires. This means that the address is reserved, even if the user is not logged in.

When a public IP address is assigned to a user:

- The user cannot access any VLANs, VPNs, or GRE tunnels configured on the controller.
- The user cannot establish more than one concurrent session.

NOTE: If a user's account is configured for public IP address support and there is no free public IP address in the pool when the user tries to login, the login is refused.

Assigning public IP addresses to users

To obtain a public IP address, a user's account must have its **Public IP address** option enabled. Do this as follows:

- If using the local user accounts option (defined on the **Controller >> Users** menu), enable the **Public IP address** option in the account profile or subscription plan that is assigned to the user. See ["Defining account profiles" \(page 357\)](#) and ["Defining subscription plans" \(page 358\)](#).
- If using Active Directory, enable the **Public IP address** option in the account profile (see ["Defining account profiles" \(page 357\)](#)) that is assigned to an Active Directory group. To set up an Active Directory group, see ["Configuring an Active Directory group" \(page 371\)](#).
- If using a RADIUS server, add the following Colubris AV-Pair value to the users account: `use-public-ip-subnet=1`. For more information, see ["Default user public IP address" \(page 475\)](#) and ["Default user public IP address" \(page 475\)](#).

DHCP server lease time

Use this setting to define the amount of time the public IP address lease will be valid. This setting only applies to public IP addresses. It overrides the DHCP lease time set by selecting **Controller >> Network > Address allocation > DHCP server**.

Address pool

The address pool contains all the public IP addresses that can be assigned to users. You can define up to 30 addresses.

Addresses must be valid for the network to which the Internet port is connected. Specify a single address or an address range as follows: *address1 - address2*. For example, the following defines a range of 20 addresses: 192.168.1.1-192.168.1.20

Configuring the DHCP relay agent

The controller provides a flexible DHCP relay implementation. It can listen for requests on the LAN port or client data tunnel and forward them to a DHCP via any of the controllers physical or logical interfaces.

For additional flexibility, separate DHCP relay agents can be enabled on access-controlled VSCs. See ["DHCP relay agent" \(page 135\)](#).

NOTE: DHCP relay is not supported on the Internet port when it is operating as a PPPoE client or if the firewall is set to High and NAT is enabled. This is because DHCP server must be able to ping the assigned address to prevent duplicate assignments.

- ① **IMPORTANT:** You must define routes on the DHCP server, so that the DHCP server can successfully send DHCP response packets back to the DHCP relay agent on the controller. These should be static and persistent host routes that identify the IP address assigned to the controller LAN port or additional VSC relay IP address, (i.e. 192.168.1.1). On Windows, such a static route would look like this:

```
route add 192.168.1.1 mask 255.255.255.255 10.10.10.22 metric 1 p
```

To configure the global DHCP relay agent

1. Select **Controller >> Network > Address allocation**.
2. Select **DHCP relay agent**, and then **Configure**.

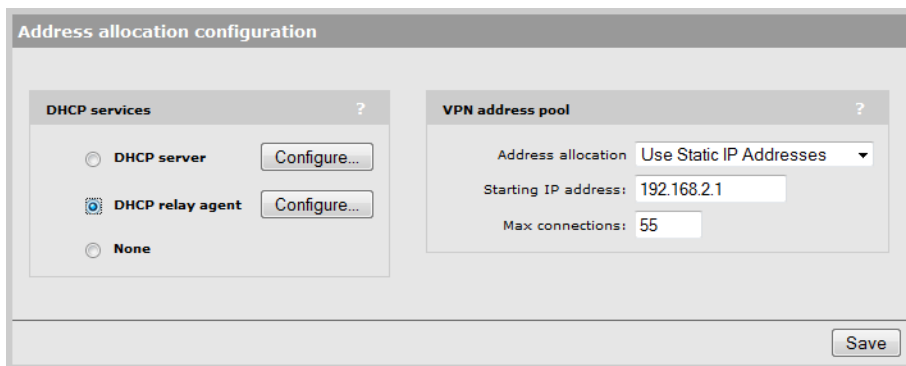

3. Under **Settings**, define the following:

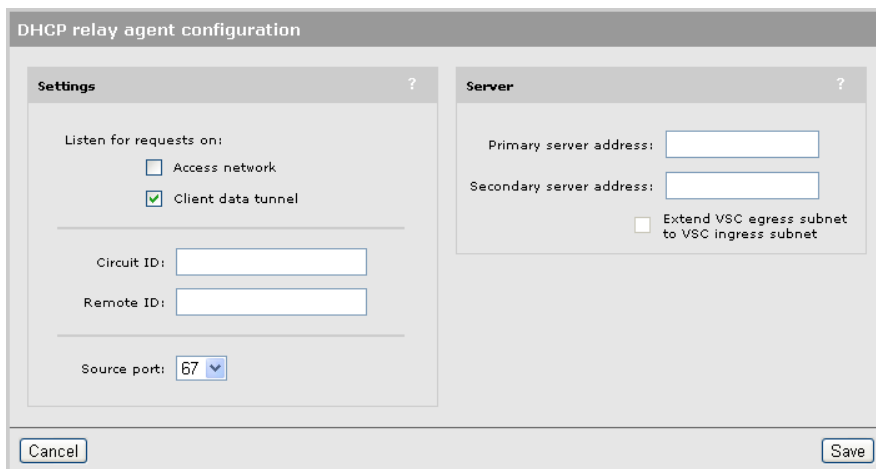

- Under **Listen for requests on**, select the interface on which the DHCP relay agent will listen for requests. Enable the **Client data tunnel** option when the client data tunnel feature is active on one or more VSCs, and you want tunneled users to be able to receive an IP address via the DHCP relay agent. See *Client data tunnel* under [“WLAN” \(page 118\)](#).
- The following two fields let you attach information to the DHCP request (as defined by DHCP relay agent information option 82) which lets the DHCP server identify the controller.
 - **Circuit ID:** Use this field to identify the user that issued the DHCP request.
 - **Remote ID:** Use this field to identify the controller.
 You can use regular text in combination with the following placeholders to create the information in each field. Placeholders are automatically expanded when the request is sent. The following placeholders can be used:
 - **%S:** SSID to which the user is associated.
 - **%B:** BSSID to which the user is associated.
 - **%V:** VLAN to which the user is mapped.
- **Source port** sets the UDP source port to use in all relayed DHCP requests. You should leave this setting at the default value of 67, unless port 68 is specifically required by your network.

4. Under **Server**, define the following:

- **Primary DHCP server address:** Specify the IP address of the first DHCP server to which the controller should forward DHCP requests.
- **Secondary DHCP server address:** Specify the IP address of the backup DHCP server to which the controller should forward DHCP requests.
- **Extend VSC egress subnet to VSC ingress subnet:** Enable this option to have the controller alter the DHCP address requests from client stations so that they appear to originate from the network assigned to the VSC egress. This will cause the DHCP server to assign IP addresses on this network to all client stations. The controller handles all mapping between the two subnets internally.

For L2 connected APs operating in controlled mode:

- Enable the **Client data tunnel** option under **Settings**. (If teaming is active, the client data tunnel is automatically used.)
- Enable the **Always tunnel client traffic** option on the VSC profile page under **Virtual AP > Client data tunnel**.

Important: Always enable this option when any VSC (other than the default VSC) is configured to use the **Forward to egress interface** option under DHCP relay agent. When controller teaming is active, do not set values for **Circuit ID** and **Remote ID**.

5. Select **Save**.

Configuring GRE tunnels

To view and configure GRE tunnel definitions, select **Controller >> Network > GRE tunnels**. Initially, no GRE tunnels are defined.

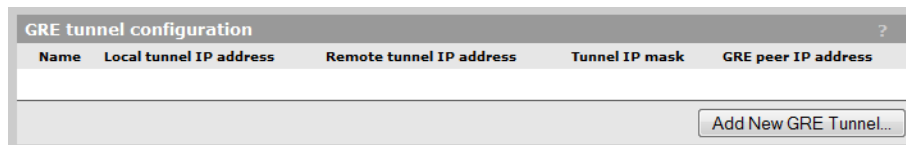

To add a tunnel, select **Add New GRE Tunnel**. The **Add/Edit GRE tunnel** page opens.

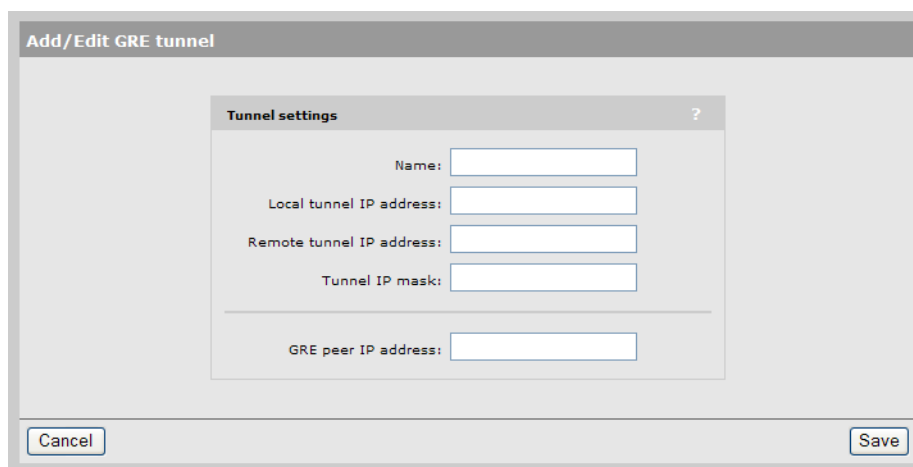

Add/Edit GRE tunnel

Tunnel settings

Name:

Local tunnel IP address:

Remote tunnel IP address:

Tunnel IP mask:

GRE peer IP address:

Cancel Save

Define tunnel settings as follows:

Name

Tunnel name.

Local tunnel IP address

Specify the IP address of the controller inside the tunnel.

Remote tunnel IP address

Specify the IP address of the remote device inside the tunnel.

Tunnel IP mask

Specify the mask associated with the IP addresses inside the tunnel.

GRE peer IP address

Specify the IP address of the remote device that terminates the tunnel.

Bandwidth control

The controller incorporates a bandwidth management feature that enables control of all user traffic flowing through the controller.

To configure bandwidth control, select **Controller >> Network > Bandwidth control**.

Level	Transmit rate		Receive rate	
	Guaranteed minimum	Maximum	Guaranteed minimum	Maximum
Very High	10 % (100 kbps)	100 % (1000 kbps)	10 % (100 kbps)	100 % (1000 kbps)
High	10 % (100 kbps)	100 % (1000 kbps)	10 % (100 kbps)	100 % (1000 kbps)
Normal	70 % (700 kbps)	100 % (1000 kbps)	70 % (700 kbps)	100 % (1000 kbps)
Low	10 % (100 kbps)	100 % (1000 kbps)	10 % (100 kbps)	100 % (1000 kbps)
Total	100%		100%	

Bandwidth control has two separate components: *Data rate limits* and *bandwidth levels*. They interact with the data stream as follows:

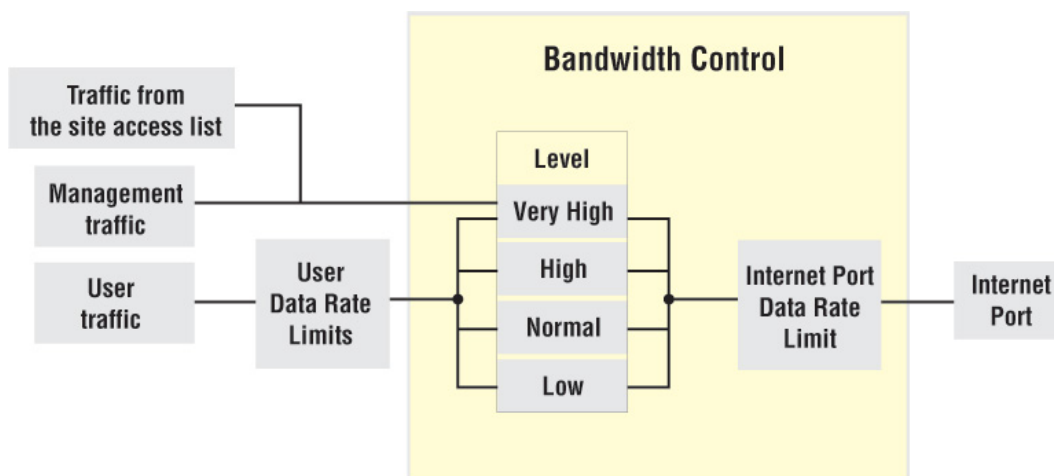

Data rate limits

These settings enable you to limit the total incoming or outgoing data rate on the Internet network profile (MSM720) or Internet port (all other controllers). If traffic exceeds the rate you set for short bursts, it is buffered. Long overages will result in data being dropped.

To utilize the full available bandwidth, the **Maximum transmit rate** and **Maximum receive rate** should be set to match the incoming and outgoing data rates supported by the connection established on the Internet port.

Bandwidth levels

The controller provides four levels of traffic priority that you can use to manage traffic flow: *Very High*, *High*, *Normal*, and *Low*. The settings for each level are customizable, allowing performance to be tailored to meet a wide variety of scenarios.

Assigning traffic to a bandwidth level

Traffic can be assigned to a specific bandwidth level for each VSC and for each user. For bandwidth control to be operational, you must first enable the **Data rate limits** option. Once this is done, you can assign traffic to bandwidth levels as follows:

- In a VSC, select the default level for all user traffic in the **Bandwidth control** box. This level applies to users who do not have a specific assignment in their user account.

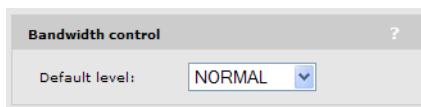

- In a users account profile, set the **Bandwidth level** in the **Bandwidth limits** box.

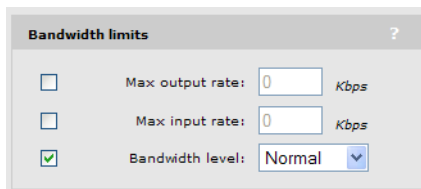

- Or if you are using a RADIUS server to validate user logins, set the bandwidth level using a Colubris AV-Pair value. See [“Bandwidth level”](#) (page 485).

To control the default bandwidth level for all users, see [“Default user bandwidth level”](#) (page 473).

NOTE:

- Management traffic (which includes RADIUS, SNMP, and administrative sessions) is assigned to bandwidth level **Very High** and cannot be changed.
 - All traffic assigned to a particular bandwidth level shares the allocated bandwidth for that level across all VSCs. This means that if you have three VSCs all assigning user traffic to High, all users share the bandwidth allocated to the High level.
-

Customizing bandwidth levels

Bandwidth levels are arranged in order of priority from Very High to Low. Priority determines how free bandwidth is allocated once the minimum rate is met for each level. Free bandwidth is always assigned to the higher priority levels first.

Bandwidth rates for each level are defined by taking a percentage of the maximum transmit and receive rates defined for the Internet port. Each bandwidth level has four rate settings:

- **Transmit rate - guaranteed minimum:** Minimum amount of bandwidth that will be assigned to a level as soon as outgoing traffic is present on the level.
- **Transmit rate - maximum:** Maximum amount of outgoing bandwidth that can be consumed by the level. Traffic in excess is buffered for short bursts, and dropped for sustained overages.
- **Receive rate - guaranteed minimum:** Minimum amount of bandwidth that will be assigned to a level as soon as incoming traffic is present on the level.
- **Receive rate - maximum:** Maximum amount of incoming bandwidth that can be consumed by the level. Traffic in excess is buffered for short bursts, and dropped for sustained overages.

Example

For example, assume that transmit bandwidth is configured as follows:

	Transmit rates	
	Min	Max
Very High	20	20
High	40	100
Normal	20	100
Low	20	20

Next, assume the following bandwidth requirement occurs on transmitted user data:

- High requires 70%, which is 30% more than its minimum.
- Normal requires 50%, which is 30% more than its minimum.
- There is no traffic on Very High or Low.

Since both High and Normal require bandwidth in excess of their guaranteed minimum, each is allocated their guaranteed minimum. This leaves 40% of the bandwidth free to be assigned on a priority basis. High has more priority than Normal, so it takes as much bandwidth as needed. In this case it is 30%, which brings High up to 70%. This leaves 10% for Normal, which is not enough. Traffic is buffered for a short period, and then dropped.

If at the same time Very High traffic is sent, this level immediately steals 20% from the lower levels. In this case, 10% is taken from Normal, returning it to its minimum guaranteed level, and 10% is taken from High.

Discovery protocols

The controller supports two protocols (LLDP and CDP) that provide a mechanism for devices on a network to exchange information with their neighbors.

To configure these protocols, select **Controller >> Network > Discovery protocols**.

On the MSM720

On all other controllers

CDP configuration

The controller can be configured to transmit CDP (Cisco Discovery Protocol) information on the LAN and Internet ports. This information is used to advertise controller information to third-party devices, such as CDP-aware switches. Network managers can retrieve this information allowing them to determine the switch ports to which different controllers are connected.

The controller always listens for CDP information on the LAN and Internet ports, even when this option is disabled, to build a list of autonomous APs. CDP information from third-party devices and controlled APs is ignored.

NOTE: Controlled APs always send CDP information.

LLDP configuration

The IEEE 802.1AB Link Layer Discovery Protocol (LLDP) provides a standards-based method for network devices to discover each other and exchange information about their capabilities. An LLDP device advertises itself to adjacent (neighbor) devices by transmitting LLDP data packets on all ports on which outbound LLDP is enabled, and reading LLDP advertisements from neighbor devices on ports that are inbound LLDP-enabled. An LLDP enabled port receiving LLDP packets inbound from neighbor devices stores the packet data in a Neighbor database (MIB).

LLDP information is used by network management tools to create accurate physical network topologies by determining which devices are neighbors and through which ports they connect.

LLDP operates at layer 2 and requires an LLDP agent to be active on each network interface that will send and receive LLDP advertisements. LLDP advertisements can contain a variable number of TLV (type, length, value) information elements. Each TLV describes a single attribute of a device.

When an LLDP agent receives information from another device, it stores it locally in a special LLDP MIB (management information base). This information can then be queried by other devices via SNMP.

Support is provided for the following MIBs:

- Physical topology MIB (RFC 2922)
- Entity MIB version 2 (RFC 2737)
- Interfaces MIB (RFC 2863)

NOTE: LLDP information is only sent/received on Ethernet links. LLDP information is not collected from wireless devices connected to an AP. However, LLDP can function across a local mesh link and will show the AP on the other side of the link as a neighbor.

NOTE: When operating in controlled mode the LLDP agents on controlled APs cannot be queried via SNMP. Instead, all LLDP information from the APs is stored in the controller's MIBs.

LLDP agent

Select this option to globally activate LLDP support on the controller.

For each port, select whether the agent will transmit and/or receive LLDP information. Select **Configure TLVs** to customize TLV support for each interface.

Transmit

Enable this option to have the agent transmit LLDP information to its neighbors.

Receive

Enable this option to have the agent accept LLDP information from its neighbors.

LLDP settings

Use these options to define global LLDP settings.

Transmit interval

Sets the interval (in seconds) at which local LLDP information is updated and TLVs are sent to neighboring network devices.

Multiplier

The value of **Multiplier** is multiplied by the **Transmit interval** to define the length of **Time to live**.

Time to live

Indicates the length of time that neighbors will consider LLDP information sent by this agent to be valid. **Time to live** is automatically calculated by multiplying **Transmit interval** by **Multiplier**.

Port Description TLV content

Select the content to be included in and advertised as part of the port description TLV.

Interface friendly name: Use the friendly name for the interface (the name you see in the management tool). For example: LAN port, Internet port.

Interface internal name: Use the internal name for the interface. For example: eth0, eth1.

Generate dynamic system names

When enabled, this feature replaces the system name with a dynamically generated value which you can define.

Controller name

Specify how the dynamically generated name will be created. You can use regular text in combination with placeholders to create the name. Placeholders are automatically expanded each time the name is regenerated.

If the placeholders cause the generated name to exceed 32 characters, it is truncated.

Placeholders

%RN: System name of the neighboring device to which the port is connected, obtained via the System Name TLV. Since this is an optional TLV, if it is not available, the Chassis ID TLV is used instead.

%RP: Port description of the port on the neighboring device to which the local port is connected, obtained via the Port Description TLV. Since this is an optional TLV, if it is not available, the Port ID TLV is used instead.

%SN: Controller name suffix (if specified). Up to 16 characters can be appended to the name. To define the suffix for APs, select **Configuration > LLDP**.

%IP: Controller's IP address. An IP address can require up to 15 characters (nnn.nnn.nnn.nnn).

Expanded Controller name

Specify how the dynamically generated name will be created. You can use regular text in combination with placeholders to create the name. Placeholders are automatically expanded each time the name is regenerated.

If the placeholders cause the generated name to exceed 32 characters, it is truncated.

Update AP names every

Specify the interval at which dynamic names for all controlled APs are updated.

To define the dynamic names for APs, select **Controlled APs >> Configuration > LLDP**.

To create the system name, the items are concatenated using a hyphen as separator. For example:

systemname-portid-suffix

NOTE:

- Once AP names are dynamically changed by this feature, there is no way to return to the original AP names.
 - When the LLDP agent is active on both the LAN port (Access Network on the MSM720) and the Internet port (Internet Network on the MSM720), the name generated on the LAN port is used for both interfaces.
 - The dynamic name on the controller is only updated when a change is detected in the neighbor to which a port is connected.
-

TLV settings

To customize TLV settings, select **Configure TLVs** on the **Controller >> Network > Discovery protocols** page.

The screenshot shows a configuration window titled "TLV support - Port 1". It is split into two panes. The left pane, "Basic TLVs", contains "Mandatory TLVs" with fields for Chassis ID (00:24:a8:88:50:58), Port ID (00:24:a8:88:50:58), and Time To Live (150). Below that are "Optional TLVs" with four checked checkboxes: Port description (Port 1), System name (SG00725W8T), System description (AP_Autonomous,SG), and System capabilities (WLAN Access Point). A Management address field is set to 0.0.0.0. The right pane, "802.3 TLVs", has one unchecked checkbox for MAC/PHY configuration/status. "Cancel" and "Save" buttons are at the bottom.

Basic TLVs

The AP supports all mandatory and optional TLVs (type, length, value) information elements that are part of the basic management set.

Mandatory TLVs

The AP always sends these TLVs with the values as shown.

Chassis ID

(Type 1): The MAC address of the AP.

Port ID

(Type 2): The MAC address of the port on which the TLV will be transmitted.

Time to live

(Type 3): Defines the length of time that neighbors will consider LLDP information sent by this agent to be valid. Calculated by multiplying **Transmit interval** by the **Multiplier** (as defined on the **Discovery protocols** page).

Optional TLVs

Select the optional TLVs that you want to send with the values as shown.

Port description

(Type 4): A description of the port.

System name

(Type 5): Administrative name assigned to the device from which the TLV was transmitted. By default this is the SNMP system name. If the **Generate dynamic system names** option is enabled, the system name is replaced by the dynamically generated name. **The**

controller can only have one system name. If both the LAN and Internet ports have active agents, then the name generated by the LAN port is used.

System description

(Type 6): Description of the system, comprised of the following information: operational mode, hardware type, hardware revision, and firmware version.

System capabilities

(Type 7): Indicates the primary function of the device. Set to:

WLAN access point

for APs

Router

for controllers.

Management IP address

(Type 8): Specify the IP address on which the agent will respond to management requests.

802.3 TLVs

The IEEE 802.3 organizationally specific TLV set is optional for all LLDP implementations. The AP supports a single optional TLV from the 802.3 definition.

MAC/PHY configuration/status

This TLV provides the following information:

- Bit-rate and duplex capability
- Current duplex and bit-rating
- Whether these settings were the result of auto-negotiation during link initiation or manual override.

DNS configuration

The controller provides several options to customize DNS handling. To configure these options, select **Controller >> Network > DNS**. The configuration options on this page change depending on the address option that is active on the Internet port.

When the Internet port (Internet network on the MSM720) is configured to obtain an IP address via PPPoE or DHCP:

DNS

DNS servers ?

Dynamically assigned DNS servers

Server 1:
Server 2:
Server 3:

Override dynamically assigned DNS servers

Server 1:
Server 2:
Server 3:

DNS advanced settings ?

DNS cache
 DNS switch on server failure
 DNS switch over
 DNS interception

Logout host name:
Logout IP address:

Save

When the Internet port (Internet network on the MSM720) is configured to use a static IP address:

The screenshot shows a web-based configuration page for DNS. The title bar says 'DNS'. There are two main panels. The left panel, 'DNS servers', has three text input boxes for 'Server 1:', 'Server 2:', and 'Server 3:'. The right panel, 'DNS advanced settings', has four checkboxes: 'DNS cache' (checked), 'DNS switch on server failure' (unchecked), 'DNS switch over' (unchecked), and 'DNS interception' (unchecked). Below these are two more text input boxes for 'Logout host name:' and 'Logout IP address:'. A 'Save' button is at the bottom right.

NOTE: When using Active Directory for user authentication, set the DNS servers to be the Active Directory servers or the devices that provide SRV records. (Important: The controller cannot be used with an Active Directory domain that is configured to support multiple DNS servers balanced by the *Round Robin* feature.)

DNS servers

Dynamically assigned servers

Shows the DNS servers that are dynamically assigned to the controller when PPPoE or DHCP is used to obtain an IP address on the Internet port.

Override dynamically assigned DNS servers

Enable this checkbox to use the DNS servers that you specify on this page to replace those that are assigned to the controller.

Server 1

Specify the IP address of the primary DNS server for the controller to use.

Server 2

Specify the IP address of the secondary DNS server for the controller to use.

Server 3

Specify the IP address of the tertiary DNS server for the controller to use.

DNS advanced settings

DNS cache

Enable this checkbox to activate the DNS cache. Once a host name is successfully resolved to an IP address by a remote DNS server, it is stored in the cache. This speeds up network performance, because the remote DNS server does not have to be queried for subsequent requests for this host.

An entry stays in the cache until one of the following is true:

- An error occurs when connecting to the remote host.
- The time to live (TTL) of the DNS request expires.
- The controller restarts.

DNS switch on server failure

Controls how the controller switches between servers:

- When enabled, the controller switches servers if the current server replies with a DNS server failure message.
- When disabled, the controller switches servers if the current server does not reply to a DNS request.

DNS switch over

Controls how the controller switches back to the primary server.

- When enabled, the controller switches back to the primary server once the primary server becomes available again.
- When disabled, the controller switches back to the primary server only when the secondary server becomes unavailable.

DNS interception

When enabled, the controller intercepts all DNS requests and relays them to the configured DNS servers. DNS interception must be enabled to support:

- Redirection of users to the public access interface login page when the controller cannot resolve the domain requested by the user. For example, if the user is using a private or local domain as the default home page in its browser.
- Users with static IP addresses when the **Allow any IP address** option is enabled on the **Controller >> Public access > Access control** page.

When disabled, the controller does not intercept any DNS requests, enabling devices to use a DNS server other than the controller. To support this option, you must set **Controller >> Network > Address allocation** to **DHCP relay agent** or **Static**.

NOTE: When **Controller >> Network > Address allocation** is set to **DHCP Server** the controller always returns its own address as the DNS server.

Defining IP routes

The routing module on the controller provides the following features:

- Compliance with RFC 1812, except for multicast routing
- Supports Classless Inter Domain Routing (CIDR)
- Supports Routing Internet Protocol (RIP) versions 1 and 2 in active or passive mode.

Output from the router is sent to the appropriate logical interface based on the target address of the traffic. Supported logical interfaces include:

- VLAN
- Untagged
- IPSec client
- PPTP client
- GRE tunnel

Configuring IP routes

To view and configure IP routes, select **Controller >> Network > IP routes**.

On the MSM720

Active routes ?					
Interface	Destination	Mask	Gateway	Metric	Delete
Internet network	15.226.15.0	255.255.255.128	*	0	
Access network	192.168.1.0	255.255.255.0	*	0	
	<input type="text"/>	<input type="text"/>	<input type="text"/>	<input type="text"/>	<input type="button" value="Add"/>

Default routes ?			
Interface	Gateway	Metric	Delete
Internet network	15.226.15.1	1	
	<input type="text"/>	<input type="text"/>	<input type="button" value="Add"/>

Persistent routes ?				
Interface	Destination	Mask	Gateway	Delete
PPTP Client	<input type="text"/>	<input type="text"/>		<input type="button" value="Add"/>

On all other controllers

Active routes ?					
Interface	Destination	Mask	Gateway	Metric	Delete
Internet port	15.226.15.0	255.255.255.128	*	0	
LAN port	192.168.1.0	255.255.255.0	*	0	
	<input type="text"/>	<input type="text"/>	<input type="text"/>	<input type="text"/>	<input type="button" value="Add"/>

Default routes ?			
Interface	Gateway	Metric	Delete
Internet network	15.226.15.1	1	
	<input type="text"/>	<input type="text"/>	<input type="button" value="Add"/>

Persistent routes ?				
Interface	Destination	Mask	Gateway	Delete
PPTP Client	<input type="text"/>	<input type="text"/>		<input type="button" value="Add"/>

Active routes

This table shows all active routes on the controller. You can add routes by specifying the appropriate parameters and then selecting **Add**.

The routing table is dynamic and is updated as needed. This means that during normal operation the controller adds routes to the table as required. You cannot delete these system routes.

The following information is shown for each active route:

- **Interface:** The port through which traffic is routed. When you add a route, the controller automatically determines the interface to be used based on the **Gateway** address.
- **Destination:** Traffic addressed to this IP address or subnet is routed.
- **Mask:** Number of bits in the destination address that are checked for a match.
- **Gateway:** IP address of the gateway to which the controller forwards routed traffic (known as the next hop).

An asterisk is used by system routes to indicate a directly connected network.

Routes cannot be manually specified for IPSec. These routes are automatically added by the system based on the settings for the IPSec security association.

- **Metric:** Priority of a route. If two routes exist for a destination address, the controller chooses the one with the lower metric.
- **Delete:** Select the garbage can icon to delete a route. If the icon has a red line through it, then the route cannot be deleted.

Default routes

The **Default routes** table shows all default routes on the controller. Default routes are used when traffic does not match any route in the Active routes table. You can add routes by specifying the appropriate parameters and then selecting **Add**.

The routing table is dynamic and is updated as needed. If more than one default route exists, the first route in the table is used.

The following information is shown for each default route:

- **Interface:** The port through which traffic is routed. When you add a route, the controller automatically determines the interface to be used based on the **Gateway** address.
- **Gateway:** IP address of the gateway to which the controller forwards routed traffic (known as the next hop).

An asterisk is used by system routes to indicate a directly connected network.

- **Metric:** Priority of a route. If two routes exist for a destination address, the controller chooses the one with the lower metric.
- **Delete:** Select the garbage can icon to delete a route. If the icon has a red line through it, then the route cannot be deleted.

Persistent routes

Persistent routes are automatically deleted and then restored each time the interface they are associated with is closed and opened. When the routes are active, they also appear in the Active routes table.

PPTP client

The controller provides an **Auto-route discovery** option to enable it to automatically discover and add routes for IP addresses on the other side of a Point-to-Point Tunneling Protocol (PPTP) tunnel. The addresses must be part of the remote domain as specified on the **Controller >> VPN > PPTP client** page. Routes are added only when an attempt is made to access the target addresses.

Settings

About PPTP client routes (Internet port)

If you disabled the **Auto-route discovery** option (**VPN > PPTP client**), or if you need to access IP addresses that are not part of the specified domain, you must define the appropriate persistent routes.

About PPTP server routes (Internet port)

Activation of the route can be triggered by a specific username. When a user establishes a connection with the controller PPTP server, its username is checked against the persistent routes list and if a match is found, the route is enabled.

Network address translation

Network address translation (NAT) is an address mapping service that enables one set of IP addresses to be used on an internal network, and a second set to be used on an external network. NAT handles the mapping between the two sets of addresses.

Generally NAT is used to map all addresses on an internal network to a single address for use on an external network like the Internet. The main benefits are that NAT:

- Enables several devices to share a single connection
- Effectively hides the IP addresses of all devices on the internal network from the external network.

This is illustrated as follows:

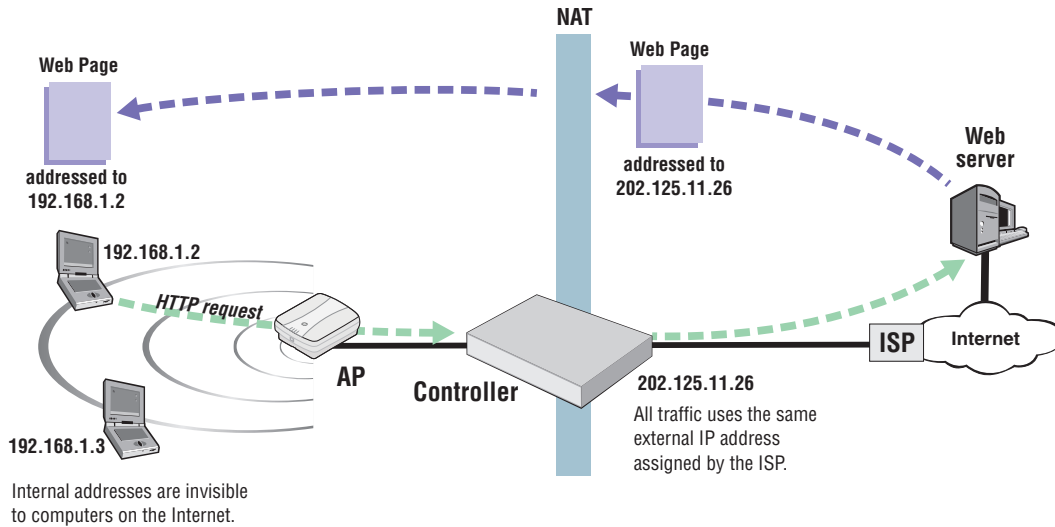

NAT can be useful in conjunction with virtual private network (VPN) connections. When two networks are connected through a VPN tunnel, it may be desirable to obscure the address of local computers for security reasons.

NAT security and static mappings

One of the benefits of NAT is that it effectively hides the IP addresses of all devices on the internal network an external network. In some cases, however, it is useful to make a computer on the internal network accessible externally. For example, a Web server or FTP server.

Static NAT mapping addresses this problem. Static NAT mapping enables you to route specific incoming traffic to an IP address on the internal network. For example, to support a Web server, you can define a static NAT mapping to route traffic on TCP port 80 to an internal computer running a Web server.

A static NAT mapping allows only one internal IP address to act as the destination for a particular protocol (unless you map the protocol to a nonstandard port). For example, you can run only one Web server on the internal network.

NOTE:

- If you use a NAT static mapping to enable a secure (HTTPS) Web server on the internal network on TCP port 443, remote access to the **management tool** is no longer possible, as all incoming HTTPS requests are routed to the internal Web server and not to the **management tool**. **You can change the default management port (TCP 443) to an alternate unused TCP port in this case.**
- If you create a static mapping, the firewall is automatically opened to accept the traffic. However, this firewall rule is not visible on the Firewall configuration page (it is maintained internally by the controller).

Common applications are affected by NAT as follows:

Application	NAT
FTP (passive mode)	Requires a static mapping to function.
FTP (active mode)	Requires a static mapping to function.
NetMeeting	Requires a static mapping to function.
Telnet	Requires a static mapping to function.
Windows networking	No effect

The controller provides pre-configured static mappings for most common applications, which you can enable as needed.

Most Web browsers use FTP in active mode. Some browsers provide a configuration option that enables you to alter this. Use the following steps to change this behavior in Microsoft Internet Explorer.

1. Select **Tools > Internet options** to open the **Internet options** dialog.
2. Select the **Advanced** tab.
3. Under **Browsing**, enable the **Use Passive FTP for compatibility with some firewalls and DSL modems** checkbox.

NAT example

The following example shows you how to configure static NAT mappings to run a Web server and an FTP server on the internal network. This scenario might occur if you use the controller in an enterprise environment.

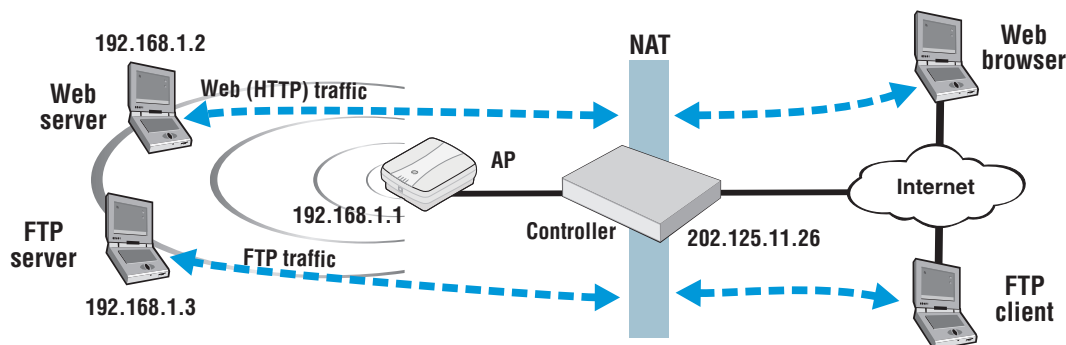

By creating static NAT mappings, FTP and HTTP (Web) traffic can be routed to the proper user. Note that the addresses of these stations are still not visible externally. Remote computers send their requests to 202.125.11.26, and the controller routes them to the proper client.

Use the following steps to configure the controller to support this example:

1. Select **Controller >> Network > NAT > Add New Static NAT Mapping**.
2. On the NAT mappings page, select **Add New Static NAT Mapping**.
3. Under **Requests for**, select **Standard Services**, and then select **http (TCP 80)**.
4. Under **Translate to**, specify the IP address of the Web server, for example **192.168.1.2**. The Settings box should now look similar to this:

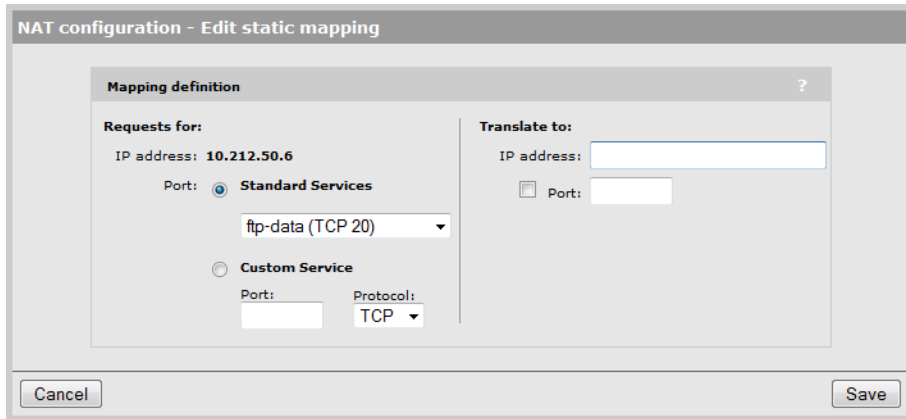

5. Select **Add** to save your changes and return to the NAT mappings page. The new mapping is added to the table.
6. To support the FTP server, create two additional mappings with the following values:
 - Set **Standard Services** to **ftp-data (TCP 20)** and set **IP address** to **192.168.1.3**.
 - Set **Standard Services** to **ftp-control (TCP 21)** and set **IP address** to **192.168.1.3**.

The NAT mappings table should now show all three mappings:

Server IP address	Service name	Protocol	Port
192.168.1.2	http	TCP	80 --> 80
192.168.1.3	ftp-data	TCP	20 --> 20
192.168.1.3	ftp-control	TCP	21 --> 21

Add New Static NAT Mapping...

VPN One-to-one NAT

This feature can only be used with authenticated, access-controlled users. It is only supported when a static IP address is assigned to the Internet network on the MSM720, or the Internet port on all other controllers. See [“VPN one-to-one NAT” \(page 515\)](#).

IP QoS

To ensure that critical applications have access to the required amount of wireless bandwidth, you can classify packets destined for the wireless interface into priority queues based on a number of criteria. For example, you can use any of the following to place data packets in one of four priority queues for transmission onto the wireless interface:

- TCP source port
- UDP source port
- Destination port
- Port ranges

You configure IP quality of service (QoS) by creating IP QoS profiles that you can then associate with VSCs or use for global wireless settings. You can configure as many as 32 IP QoS profiles on the controller. You can associate as many as 10 IP QoS profiles with each VSC.

Configuring IP QoS profiles

To view and configure IP QoS profiles, select **Controller >>Network > IP QoS**. Initially, no profiles are defined.

IP QoS profiles				
Name	Protocol	Start port	End port	Priority
SNMP	6 (TCP)	161 (SNMP)	161	High
Web	6 (TCP)	80 (http)	80	Low

Add New Profile...

To create an IP QoS profile, select **Add New Profile**.

Add/Edit IP QoS profile

Settings

Profile name:

Protocol: Other

Start port: Other

End port:

Priority: Low

Settings

- **Profile name:** Specify a unique name to identify the profile.
- **Protocol:** Specify an IP protocol to use to classify traffic by specifying its Internet Assigned Numbers Authority (IANA) protocol number. Protocol numbers are pre-defined for a number of common protocols. If the protocol you require does not appear in the list, select **Other** and specify the appropriate number manually. You can find IANA-assigned protocol numbers on the Internet.
- **Start port/ End port:** Optionally specify the first and last port numbers in the range of ports to which this IP QoS profile applies. To specify a single port, specify the same port number for both Start port and End port. Port numbers are pre-defined for a number of common protocols. If the protocol you require does not appear in the list, select **Other** and specify the appropriate number manually.

NOTE: To accept traffic on all ports for a specified protocol, set **Start port** to **Other** and **0**. Also set **End port** to **65535**.

- **Priority:** Select the priority level that will be assigned to traffic that meets the criteria specified in this IP QoS profile.

NOTE: It is strongly recommended that you reserve **Very high** priority for voice applications.

Example

This example shows how to create two IP QoS profiles and associated them with a VSC. The two profiles are:

- **Voice:** Provides voice traffic with high priority.
- **Web:** Provides HTTP traffic with low priority.

Create the profiles

1. Select **Controller >>Network > IP QoS**, and then **Add New Profile**. The **IP QoS Profile** page opens.
2. Under **Profile name**, specify **Voice**.

- Under **Protocol**, from the drop-down list select **TCP**.
- Under **Start port**, from the drop-down list select **SIP**. **Start port** and **End port** are automatically populated with the correct value: **5060**.
- Under **Priority**, from the drop-down list select **Very High**.

The screenshot shows a dialog box titled "Add/Edit IP QoS profile". Inside, there is a "Settings" section with the following fields:

- Profile name: Voice
- Protocol: TCP (dropdown), 6 (text input)
- Start port: SIP (dropdown), 5060 (text input)
- End port: 5060 (text input)
- Priority: Very high (dropdown)

 At the bottom of the dialog, there are "Cancel" and "Save" buttons.

- Select **Save**.

NOTE: You could also create another profile using the same parameters but for UDP to cope with any kind of SIP traffic.

- On the **IP QoS Profile** page select **Add New Profile**.
- Under **Profile name**, specify **Web**.
- Under **Protocol**, from the drop-down list select **TCP**.
- Under **Start port**, from the drop-down list select **http**. **Start port** and **End port** are automatically populated with the common HTTP port, **80**.
- Under **Priority**, from the drop-down list select **Low**.

The screenshot shows a dialog box titled "Add/Edit IP QoS profile". Inside, there is a "Settings" section with the following fields:

- Profile name: Web
- Protocol: TCP (dropdown), 6 (text input)
- Start port: http (dropdown), 80 (text input)
- End port: 80 (text input)
- Priority: Low (dropdown)

- Select **Save**.

Assign the profiles to a VSC

- In the **Network Tree**, select **VSCs**, and then select one of the VSC profiles in the **Name** column. Scroll down to the **Quality of service** section in the **Virtual AP** box.

The screenshot shows a section titled "Quality of service". It contains:

- Priority mechanism: IP QoS (dropdown)
- IP QoS profiles: A dropdown menu showing "Voice" and "Web" as options.

- Under **Quality of service**, set **Priority mechanism** to **IP QoS**.

3. In **IP QoS profiles**, Ctrl-click each profile.
4. Select **Save**.

Customizing DiffServ DSCP mappings

(These settings do not apply to IP QoS.)

You can create custom DSCP mappings that let you override the standard DSCP mappings that are defined by default when you enable DiffServ as the QoS priority mechanism for a VSC or for local mesh links. This enables you to customize how traffic is assigned to the QoS priority queues.

To view and configure DSCP mappings, select **Controller >>Network > IP QoS**. Initially, no mappings are defined.

DSCP mappings		
DSCP tag	Priority	Delete
	Background	

DSCP tag DSCP codepoint value.

Priority Indicates the priority level assigned to traffic that matches the DSCP tag.

- **Background:** Assigns the traffic to queue 4 (Lowest priority).
- **Best effort:** Assigns the traffic to queue 3.
- **Video:** Assigns the traffic to queue 2.
- **Voice:** Assigns the traffic to queue 1 (Highest priority).

To create a new mapping

Specify a value for **DSCP tag**, select a **Priority**, and then select **Add**.

DSCP mappings		
DSCP tag	Priority	Delete
12	Background	

IGMP proxy

This feature provides support for multicast routing using IGMP (Internet Group Management Protocol), which is typically required by the controller. When enabled, the controller:

- Routes all multicast traffic received on the Upstream interface to the Downstream interface.
- Listens for IGMP host membership reports from authenticated users on the Downstream interface and forwards them to the Upstream interface. IGMP host membership reports from unauthenticated users are ignored.

NOTE:

- An access list definition must be created to accept the multicast traffic (video streams, etc.).
- Due to the nature of multicast traffic, once a user registers for a stream it automatically becomes visible to unauthenticated users as well. However, unauthenticated users are not able to register with the IGMP group.

To view and configure IGMP proxy settings, select **Controller >> Network > IGMP proxy**.

On the MSM720

IGMP proxy

Settings ?

Enabled Disabled

Upstream interface: Internet network ▼

Downstream interface: Access network ▼

Save

On all other controllers

IGMP proxy

Settings ?

Enabled Disabled

Upstream interface: Internet port ▼

Downstream interface: LAN port ▼

Save

5 Port trunking

Port trunking enables the MSM720 to combine multiple physical links into a single logical link (trunk) to provide redundancy in the case of link failure.

The MSM720 supports static trunking, and dynamic trunking using the LACP (Link Aggregation Control Protocol).

Possible applications for trunking include:

- **Creating a high-availability trunk to send egress traffic from the controller to a network:** In this example, a static trunk is created using ports 5 and 6 to send all traffic from APs located on different networks onto a private network. The trunk has two links, providing redundancy in the case of link failure.

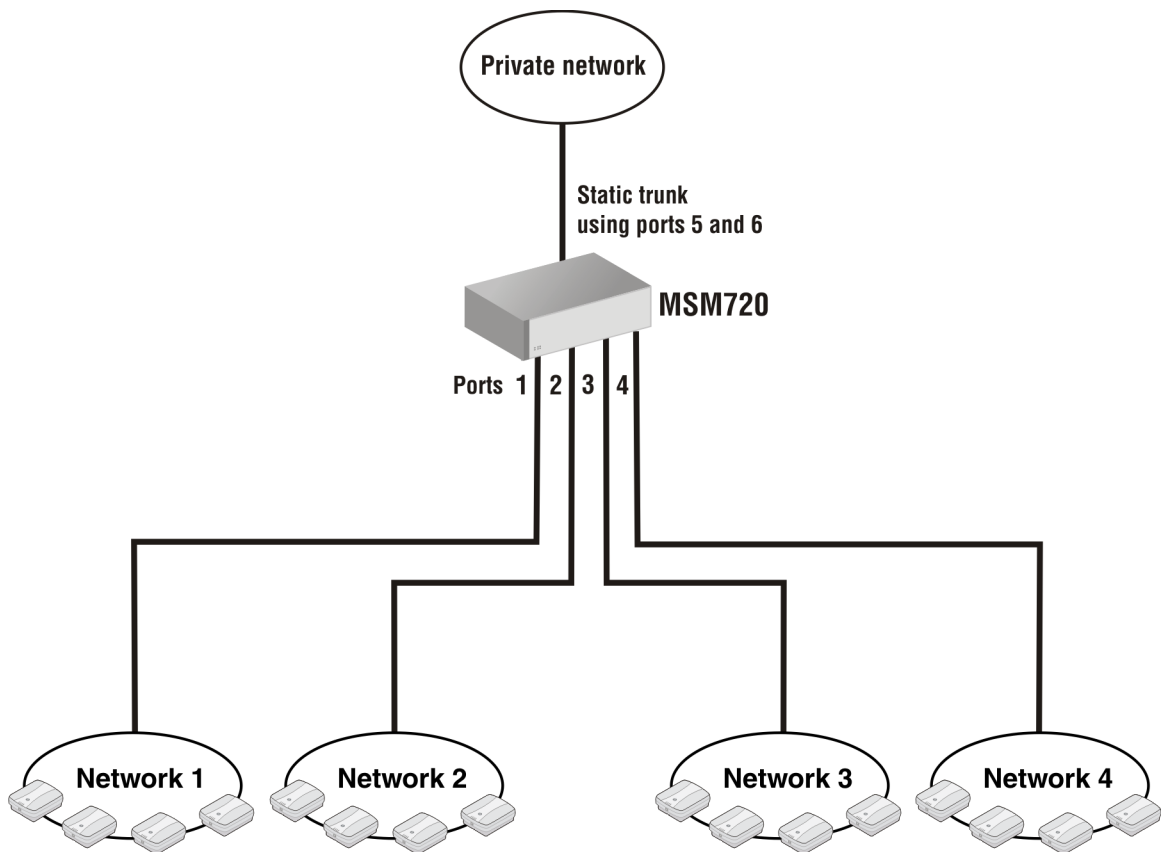

- **Creating a high-availability trunk to tunnel traffic from wireless client stations to the controller:** In this example, a dynamic trunk is created between the switch and the controller to consolidate all traffic from the controlled APs. The trunk has six links, providing redundancy in the case of link failure. (Only two links can be active at any given time. The remainder act as backups.)

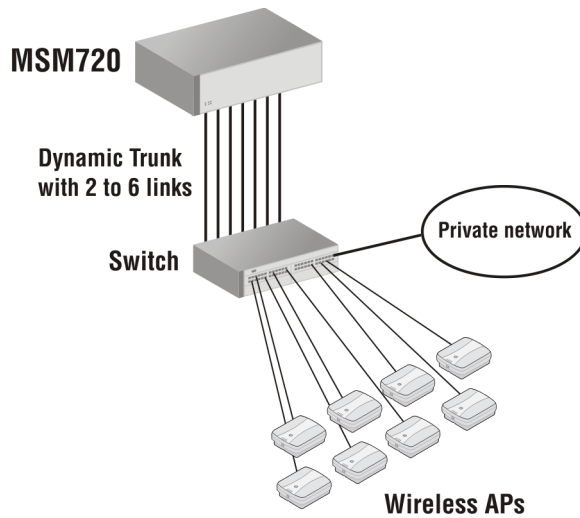

- **Creating multiple trunks for traffic aggregation and routing:** This example shows two trunks being used to aggregate traffic from APs, while a third trunk is used to egress traffic onto the private network.

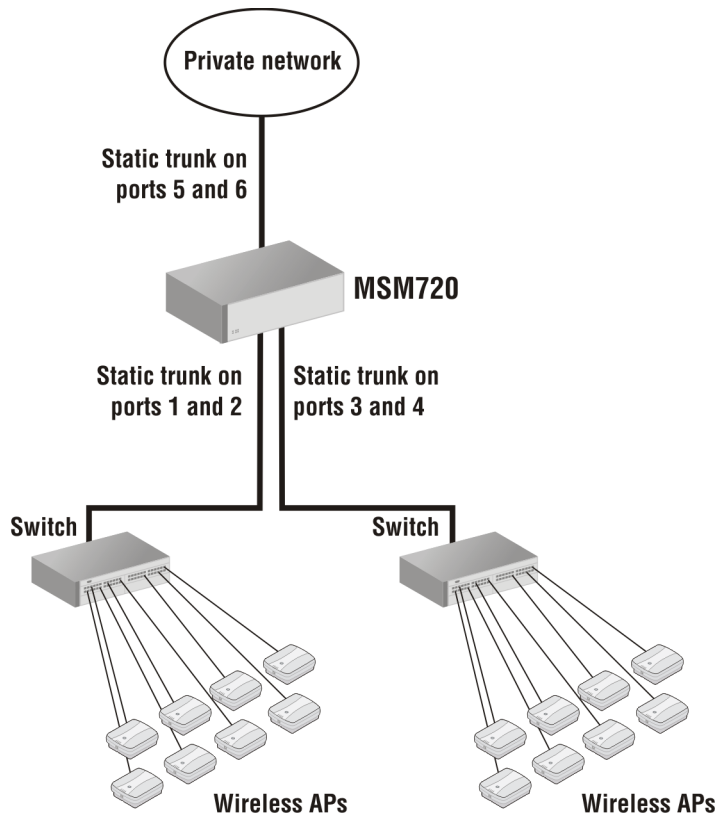

Deployment considerations

- All port trunk links must be point-to-point connections between the MSM720 and the other device configured for port trunking (switch, router, server, etc.) No intervening, non-trunking devices are allowed.
- To avoid broadcast storms or loops in your network while configuring a trunk, first disable or disconnect all ports you want to add to the trunk. After you finish configuring the trunk, enable or re-connect the ports.

- A maximum of six trunks can be created.
- Static trunks and dynamic trunks are supported at the same time.

Static trunks

- Ports on both ends of a static trunk must have the same link speed and duplex settings, and be of the same media type (Ethernet or fiber).
- A static trunk can combine a maximum of two ports.
- A static trunk can support multiple tagged and untagged VLANs.

Dynamic trunks

- All ports in a dynamic trunk must have the same media type (Ethernet or fiber) and speed. (LACP enforces speed and duplex conformance across a trunk group.) For most installations, HP recommends that you leave the port speed and duplex settings at Auto (the default).
- A dynamic trunk can combine two active ports and up to four standby ports. The MSM720 automatically activates standby ports as required.
- The MSM720 only supports LACP in active mode. However, it can connect to LACP ports operating in passive mode.
- Each dynamic trunk supports a single untagged VLAN (called the default VLAN). This means that traffic on the trunk is untagged, but internally within the controller traffic is tagged with a VLAN ID for routing purposes.
- GVRP is not supported.

Creating a static trunk

This section describes how to create a static trunk using two ports. For the purposes of this example, the trunk will connect to an HP switch using ports 3 and 4 on the MSM720. Traffic on the trunk will be tagged with VLAN 11.

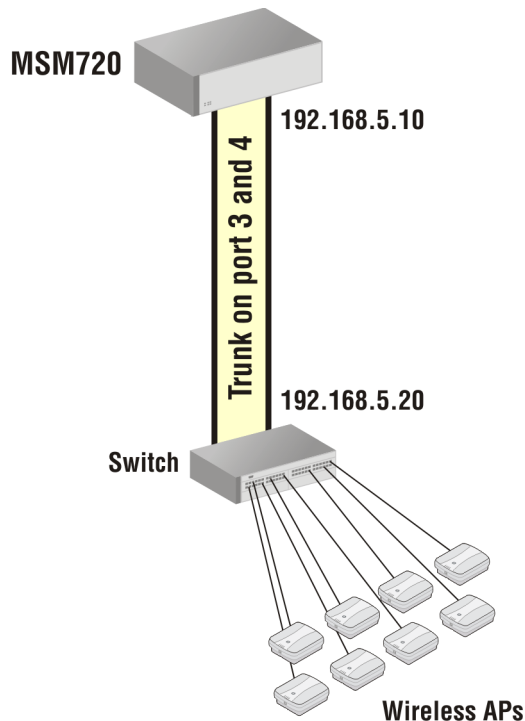

1. Select **Controller >> Network > Network profiles**.

2. Select **Add New Profile**.

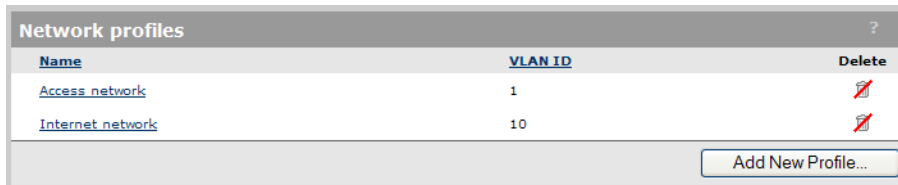

The screenshot shows a table titled "Network profiles" with a help icon in the top right. The table has three columns: "Name", "VLAN ID", and "Delete". There are two rows: "Access network" with VLAN ID 1 and "Internet network" with VLAN ID 10. Each row has a red delete icon. At the bottom right, there is a button labeled "Add New Profile..."

Name	VLAN ID	Delete
Access network	1	
Internet network	10	

3. Configure profile settings as follows:
 - Set **Name** to **Static Trunk**.
 - Select **VLAN ID** and set a value of **11**.

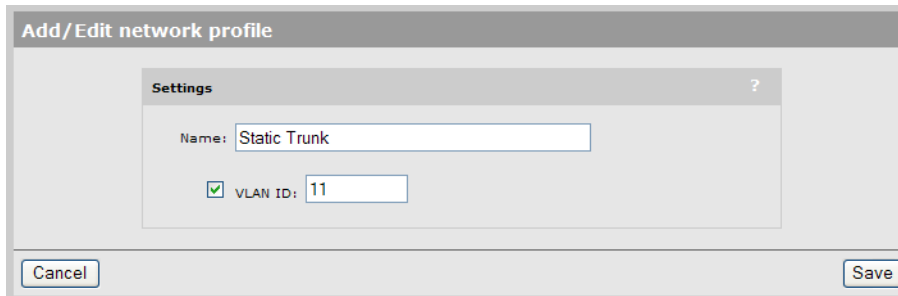

The screenshot shows a dialog box titled "Add/Edit network profile" with a help icon. Inside, there is a "Settings" section with a "Name" field containing "Static Trunk" and a "VLAN ID" field with a checked checkbox and the value "11". At the bottom, there are "Cancel" and "Save" buttons.

4. Select **Save**. The new profile appears on the Network profiles page.

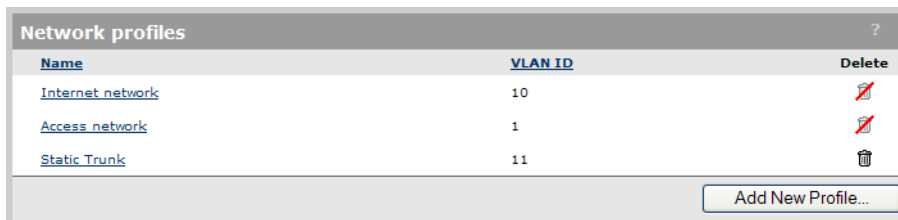

The screenshot shows the "Network profiles" table after saving. It now has three rows: "Internet network" (VLAN ID 10), "Access network" (VLAN ID 1), and "Static Trunk" (VLAN ID 11). The "Static Trunk" row has a trash can icon instead of a delete icon. The "Add New Profile..." button is still present at the bottom right.

Name	VLAN ID	Delete
Internet network	10	
Access network	1	
Static Trunk	11	

5. Select **Controller >> Network > Ports**.

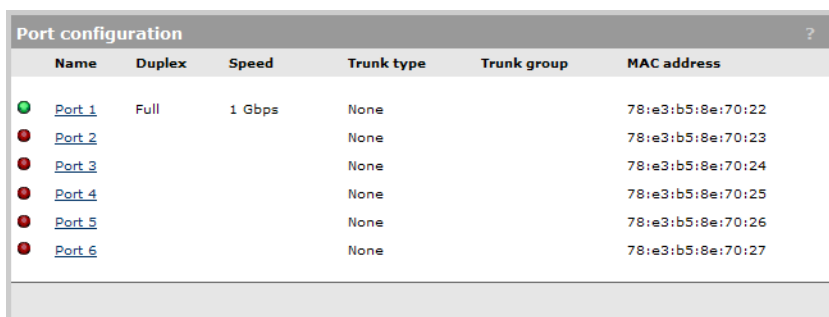

The screenshot shows a table titled "Port configuration" with a help icon. The table has six columns: "Name", "Duplex", "Speed", "Trunk type", "Trunk group", and "MAC address". There are six rows, each representing a port from "Port 1" to "Port 6". Each row has a colored status indicator (green for Port 1, red for others) and a MAC address.

Name	Duplex	Speed	Trunk type	Trunk group	MAC address
Port 1	Full	1 Gbps	None		78:e3:b5:8e:70:22
Port 2			None		78:e3:b5:8e:70:23
Port 3			None		78:e3:b5:8e:70:24
Port 4			None		78:e3:b5:8e:70:25
Port 5			None		78:e3:b5:8e:70:26
Port 6			None		78:e3:b5:8e:70:27

6. Select **Port 3**.
7. Under **Trunk settings** make the following settings:
 - Set **Type** to **Trunk**.
 - Set **Group** to **Trunk 1**.

Port 3 configuration

Trunk settings

Type:

Group:

Link settings

Speed:

Duplex:

(Currently: 1 Gbps FULL)

8. Select **Save**.
9. Select **Port 4**. Repeat steps 7 and 8. When done, the ports page will look like this:

Port configuration

Name	Duplex	Speed	Trunk type	Trunk group	MAC address
Port 1	Full	1 Gbps	None		78:e3:b5:8e:70:22
Port 2			None		78:e3:b5:8e:70:23
Port 3			Trunk	Trunk 1	78:e3:b5:8e:70:24
Port 4			Trunk	Trunk 1	78:e3:b5:8e:70:25
Port 5			None		78:e3:b5:8e:70:26
Port 6			None		78:e3:b5:8e:70:27

10. Select **Controller >> Network > VLANs**.

VLANs

Number of matching VLANs: 3 [Show all VLANs](#)

Filter VLANs by:

Select the action to apply to the selected network profiles:

<input type="checkbox"/>	<u>Network profile</u>	<u>VLAN ID</u>	<u>Location</u>	<u>Tagged</u>	<u>Untagged</u>
<input type="checkbox"/>	Access network (Default)	1	Local		1, 2, Trk1
<input type="checkbox"/>	Internet network	10	Local		5, 6
<input type="checkbox"/>	Static Trunk	11	None		

11. Select **Static Trunk**. The Add/Edit VLAN mapping page opens. (Note that under **Map To**, Port 3 and Port 4 do not appear because they are already mapped to **Trunk 1**.)

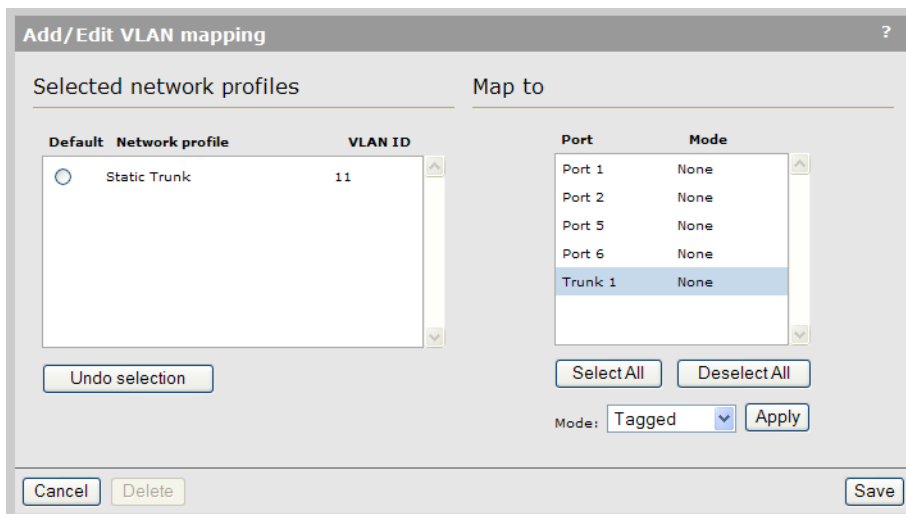

12. Under **Map to**, select **Trunk 1** and set **Mode** to **Tagged**, then select **Apply**.
13. Select **Save**. The trunk is now configured and is ready for use.

<input type="checkbox"/>	Network profile	VLAN ID	Location	Tagged	Untagged
<input type="checkbox"/>	Access network (Default)	1	Local		1, 2, Trk1
<input type="checkbox"/>	Internet network	10	Local		5, 6
<input type="checkbox"/>	Static Trunk	11	None	Trk1	

(Note that Trunk 1 remains mapped to the Access network as *untagged*. A trunk can be mapped to more than one network profile as *tagged*, but only one network profile as *untagged*. For example, if another network profile was created on VLAN 12, Trunk 1 could also be mapped to that profile as tagged. If Trunk 1 is mapped to the new profile as untagged, it will automatically be removed from the Access network.)

14. Connect port 3 and 4 to the switch.
15. Select **Controller >> Network > Ports**. The status lights for both ports should now be green.

Name	Duplex	Speed	Trunk type	Trunk group	MAC address
Port 1	Full	1 Gbps	None		78:e3:b5:8e:70:22
Port 2			None		78:e3:b5:8e:70:23
Port 3	Full	1 Gbps	Trunk	Trunk1	78:e3:b5:8e:70:24
Port 4	Full	1 Gbps	Trunk	Trunk1	78:e3:b5:8e:70:25
Port 5			None		78:e3:b5:8e:70:26
Port 6			None		78:e3:b5:8e:70:27

Creating a dynamic trunk

This section describes how to create a dynamic LACP trunk.

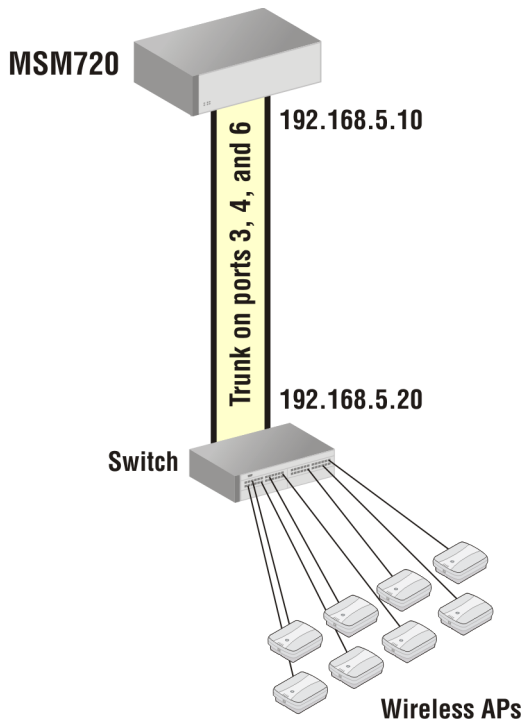

In this example, the trunk will connect to an HP switch using ports 3, 4 and 6 on the MSM720. Traffic on the trunk will use the default VLAN, which will be set to 22.

1. Select **Controller >> Network > Network profiles**.
2. Select **Add New Profile**.



3. Configure profile settings as follows:
 - Set **Name** to **LACP Trunk**.
 - Select **VLAN ID** and set a value of **22**.



4. Select **Save**. The new profile appears on the Network profiles page.

Network profiles		
Name	VLAN ID	Delete
Access network	1	
Internet network	10	
LACP Trunk	22	

[Add New Profile...](#)

5. Select **Controller >> Network > Ports**.

Port configuration					
Name	Duplex	Speed	Trunk type	Trunk group	MAC address
Port 1	Full	1 Gbps	None		78:e3:b5:8e:70:22
Port 2			None		78:e3:b5:8e:70:23
Port 3			None		78:e3:b5:8e:70:24
Port 4			None		78:e3:b5:8e:70:25
Port 5			None		78:e3:b5:8e:70:26
Port 6			None		78:e3:b5:8e:70:27

6. Select **Port 3**.
7. Under **Trunk settings**, set **Type** to **LACP**.

Port 3 configuration

Trunk settings

Type:

Group:

Link settings

Speed:

Duplex:

(Currently: Down)

8. Select **Save**.
9. Repeat steps 7 and 8 for ports 4 and 6.
10. Select **Controller >> Network > VLANs**. Currently, the Access network profile is set as the default VLAN, so ports 3, 4, 6 appear in the untagged column for this profile. Since LACP trunks always use the default VLAN, you must move it to the **LACP Trunk** profile.

VLANs					
Number of matching VLANs: 3 Show all VLANs					
Filter VLANs by: <input type="text" value="Network profile"/> <input type="button" value="Apply"/>					
Select the action to apply to the selected network profiles: <input type="text" value="-- Select an Action --"/> <input type="button" value="Apply"/>					
<input type="checkbox"/>	Network profile	VLAN ID	Location	Tagged	Untagged
<input type="checkbox"/>	Access network (Default)	1	Local		1, 2, 3, 4, 6
<input type="checkbox"/>	Internet network	10	Local		5
<input type="checkbox"/>	LACP Trunk	22	None		

11. Select **LACP Trunk**.

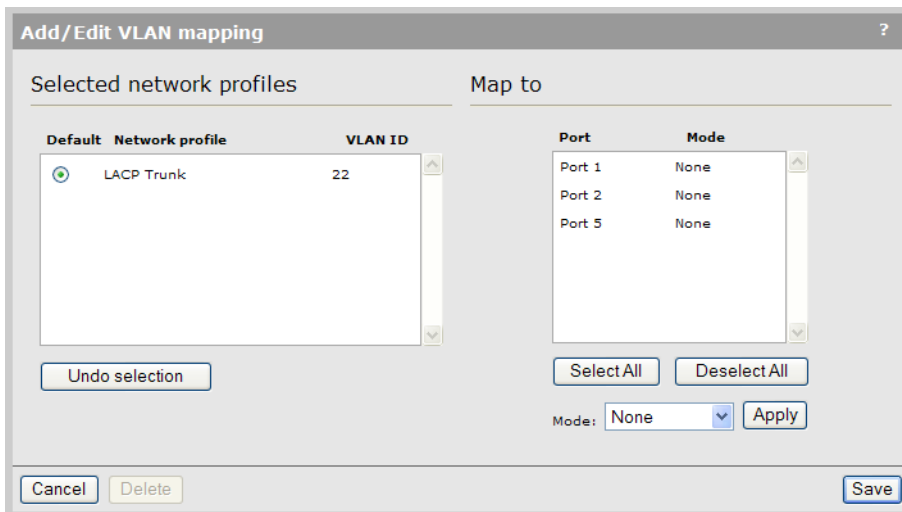

12. Under **Selected network profiles**, select **Default**. This assigns the LACP Trunk as the default VLAN (VLAN 22).

13. Select **Save**. The trunk is now configured and is ready for use.

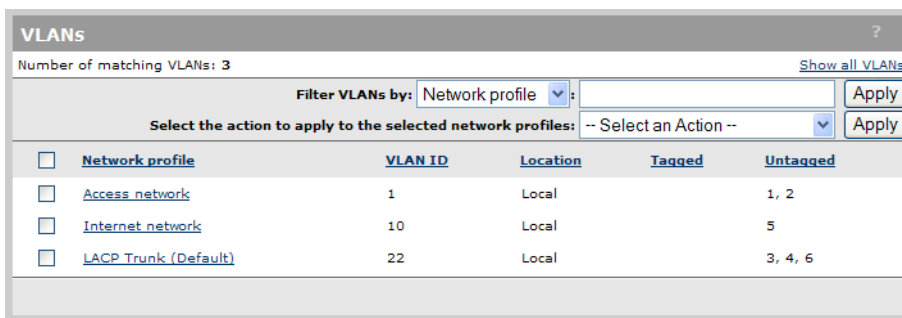

14. Connect ports 3, 4, and 6 to the switch.

15. Select **Controller >> Network > Ports**. The status lights for ports 3, 4, and 6 should be green and all ports should be assigned to Trunk type LACP and Trunk group **Dynamic 1**.

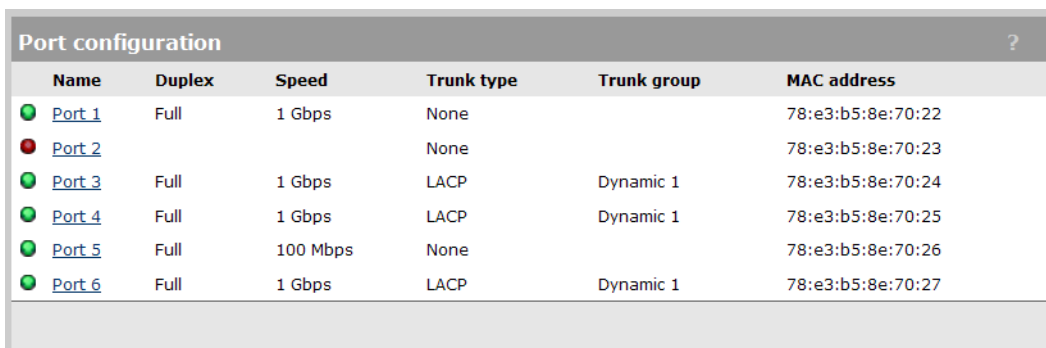

16. Select **Controller >> Network > VLANs**. The LACP trunk profile will now show as mapped to the **Dyn1** (dynamic LACP trunk #1) as untagged.

VLANs ?

Number of matching VLANs: 3 [Show all VLANs](#)

Filter VLANs by: Network profile

Select the action to apply to the selected network profiles: -- Select an Action --

<input type="checkbox"/>	<u>Network profile</u>	<u>VLAN ID</u>	<u>Location</u>	<u>Tagged</u>	<u>Untagged</u>
<input type="checkbox"/>	Access network	1	Local		1, 2
<input type="checkbox"/>	Internet network	10	Local		5
<input type="checkbox"/>	LACP Trunk (Default)	22	Local		Dyn1

17. Select **Controller >> Status > LACP**. The table indicates that:

- Ports 3 and 4 are active members of the LACP trunk and are sending traffic according to the LACP load balancing algorithm.
- Port 6 is in standby mode, waiting in case an active port fails. Traffic on the port is blocked.

LACP statistics ?

Port	Packets received	Packets sent	Packets discarded	LACP partner	LACP status
● Port 1	0	0	0	False	Collecting and Distributing
● Port 2	0	0	0	False	Collecting and Distributing
● Port 3	37	2530	0	True	Collecting and Distributing
● Port 4	61	2548	0	True	Collecting and Distributing
● Port 5	0	0	0	False	Collecting and Distributing
● Port 6	62	2526	0	True	Waiting

6 Wireless configuration

Wireless coverage

IMPORTANT: This section describes factors that affect wireless coverage. The **Radio Resource Management (RRM)** feature will account for these factors and enable you to automatically manage the wireless network for optimum performance. See [“Radio Resource Management” \(page 182\)](#).

NOTE: Supported wireless modes, operating channels, and power output vary according to the AP model, and are governed by the regulations of the country in which the AP is operating (called the regulatory domain). For a list of all operating modes, see [“Radio configuration” \(page 85\)](#). To set the regulatory domain, see [“Assigning country settings to a group” \(page 170\)](#).

Factors limiting wireless coverage

Wireless coverage is affected by the factors discussed in this section.

Radio power

More radio power means better signal quality and the ability to create bigger wireless cells. However, cell size should generally not exceed the range of transmission supported by wireless users. If it does, users will be able to receive signals from the AP but will not be able to reply, rendering the connection useless. Further, when more than one AP operates in an area, you must adjust wireless cell size to reduce interference between APs. An automatic power control feature is available to address this challenge. See [“Transmit power control” \(page 99\)](#).

Antenna configuration

Antennas play a large role in determining the shape of the wireless cell and transmission distance. See the specifications for the antennas you use to determine how they affect wireless coverage.

Interference

Interference is caused by other APs or devices that operate in the same frequency band as the AP and can substantially affect throughput. Advanced wireless configuration features are available to automatically eliminate this problem. See [“Radio configuration” \(page 85\)](#).

In addition, the several tools are available to diagnose interference problems as they occur.

- Select **Controlled APs >> Security > Neighborhood** to view a list of wireless radios operating nearby as identified by IDS scanning. See [“Neighborhood page” \(page 206\)](#).
- Enable the **Severe interface detection/mitigation** feature on the Radio configuration page to automatically switch channels when interference is detected. See [“Severe interference detection and mitigation” \(page 183\)](#).
- Select **Controlled APs >> Overview > Wireless rates** to view information about data rates for all connected client stations. This makes it easy to determine if low-speed clients are affecting network performance. To prevent low-speed clients from connecting, you can use the Allowed wireless rates option when defining a VSC. See [“Virtual AP” \(page 117\)](#).
- Select **Controlled APs >> Overview > Wireless clients** to view information about each connected wireless client.
- Select **Controlled APs > [group] > [AP] >> Status > Wireless** to view detailed wireless information for an AP, including: packets sent and received, transmission errors, and other low-level events.

△ CAUTION: APs that operate in the 2.4 GHz band may experience interference from 2.4 GHz cordless phones and microwave ovens.

Physical characteristics of the location

To maximize coverage of a wireless cell, wireless APs are best installed in an open area with as few obstructions as possible. Try to choose a location that is central to the area being served.

Radio waves cannot penetrate metal; they are reflected instead. A wireless AP can transmit through wood or plaster walls and closed windows; however, the steel reinforcing found in concrete walls and floors may block transmissions or reduce signal quality by creating reflections. This can make it difficult or impossible for a single AP to serve users on different floors in a concrete building. Such installations require a separate wireless AP on each floor.

Configuring overlapping wireless cells

Overlapping wireless cells occur when two or more APs are operating within transmission range of each other. This may be under your control, (for example, when you use several cells to cover a large location), or out of your control (for example, when your neighbors set up their own wireless networks). When APs are operating in the 2.4 GHz band, overlapping wireless cells can cause performance degradation due to insufficient channel separation.

Performance degradation and channel separation

When two wireless cells operating on the same frequency overlap, throughput can be reduced in both cells. Reduced throughput occurs because a wireless user that is attempting to transmit data defers (delays) transmission if another station is transmitting. In a network with many users and much traffic, these delayed transmissions can severely affect performance, because wireless users may defer several times before the channel becomes available. If a wireless user is forced to delay transmission too many times, data can be lost.

Delays and lost transmissions can severely reduce throughput on a network. To view this information about your network, select **Controller > Controlled APs > [group] > [AP] >> Status > Wireless**. For recommendations on using this information to diagnose wireless problems, see the online help for this page.

The following example shows two overlapping wireless cells operating on the same channel (frequency). Since both APs are within range of each other, the number of deferred transmissions can be large.

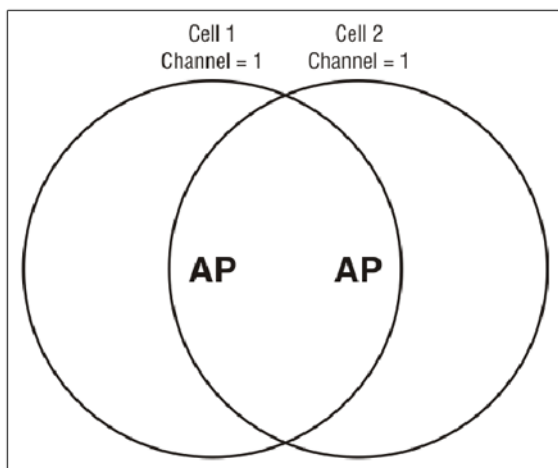

The solution to this problem is to configure the two AP to operate on different channels. Unfortunately, in the 2.4 GHz band, adjacent channels overlap. So even though APs are operating on different channels, interference can still occur. This is not an issue in the 5 GHz band, as all channels are non-overlapping.

Selecting channels in the 2.4 GHz band

In the 2.4 GHz band, the center frequency of each channel is spaced 5 MHz apart (except for channel 14). Each 802.11 channel uses 20 MHz of bandwidth (10 MHz above and 10 MHz below the center frequency), which means that adjacent channels overlap and interfere with each other as follows:

Channel	Center frequency	Overlaps channels	Channel	Center frequency	Overlaps channels
1	2412	2, 3	8	2447	6, 7, 9, 10
2	2417	1, 3, 4	9	2452	7, 8, 10, 11
3	2422	1, 2, 4, 5	10	2457	8, 9, 11, 12
4	2427	2, 3, 5, 6	11	2462	9, 10, 12, 13
5	2432	3, 4, 6, 7	12	2467	10, 11, 13
6	2437	4, 5, 7, 8	13	2472	11, 12
7	2442	5, 6, 8, 9	14	2484	

To avoid interference, APs in the same area must use channels that are separated by at least 25 MHz (5 channels). For example, if an AP is operating on channel 3, and a second AP is operating on channel 7, interference occurs on channel 5. For optimal performance, the second AP should be moved to channel 8 (or higher).

With the proliferation of wireless networks, it is possible that the wireless cells of APs outside your control overlap your intended area of coverage. To choose the best operating frequency, select **Controlled APs >> Security > Neighborhood** to view a list of all APs that are operating nearby and their operating frequencies.

The number of channels available for use in a particular country are determined by the regulations defined by the local governing body and are automatically configured by the AP based on the Country setting you define. (See [“Assigning country settings to a group” \(page 170\)](#)). This means that the number of non-overlapping channels available to you varies by geographical location.

The following table shows the number of channels that are available in North America, Japan, and Europe.

Region	Available channels
North America	1 to 11
Japan	1 to 14
Europe	1 to 13

Since the minimum recommended separation between overlapping channels is 25 MHz (five channels) the recommended maximum number of overlapping cells you can have in most regions is three. The following table gives examples relevant to North America, Japan, and Europe (applies to 22 MHz channels in the 2.4 GHz band).

North America	Japan	Europe
cell 1 on channel 1	cell 1 on channel 1	cell 1 on channel 1
cell 2 on channel 6	cell 2 on channel 7	cell 2 on channel 7
cell 3 on channel 11	cell 3 on channel 14	cell 3 on channel 13

In North America you can create an installation as shown in the following figure.

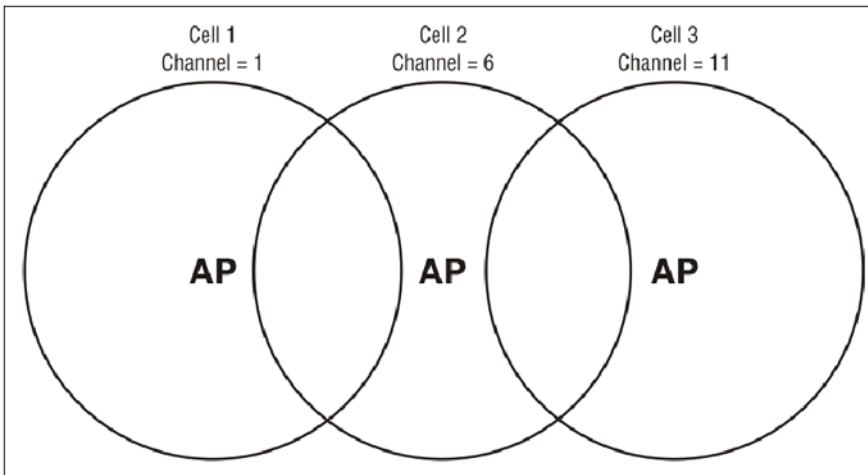

Reducing transmission delays by using different operating frequencies in North America.

Alternatively, you can stagger cells to reduce overlap and increase channel separation, as shown in the following figure.

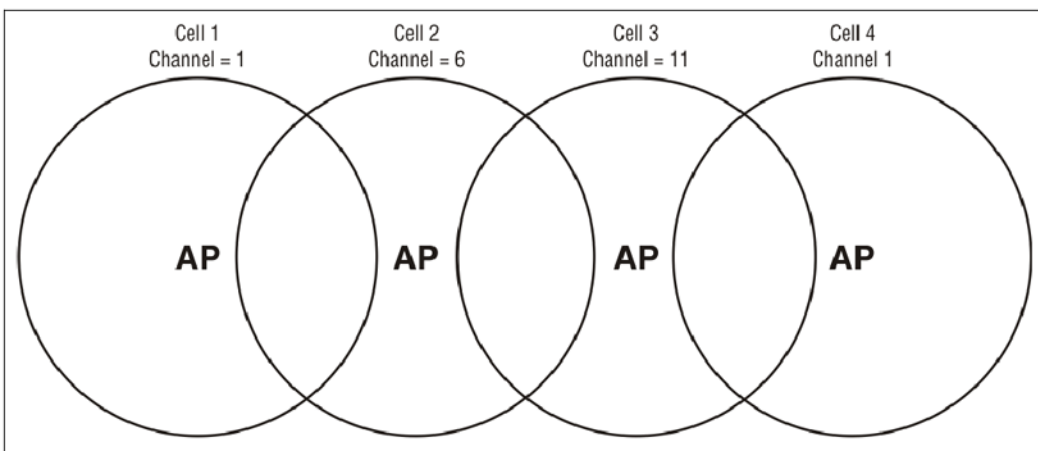

Using only three frequencies across multiple cells in North America.

This strategy can be expanded to cover an even larger area using three channels, as shown in the following figure.

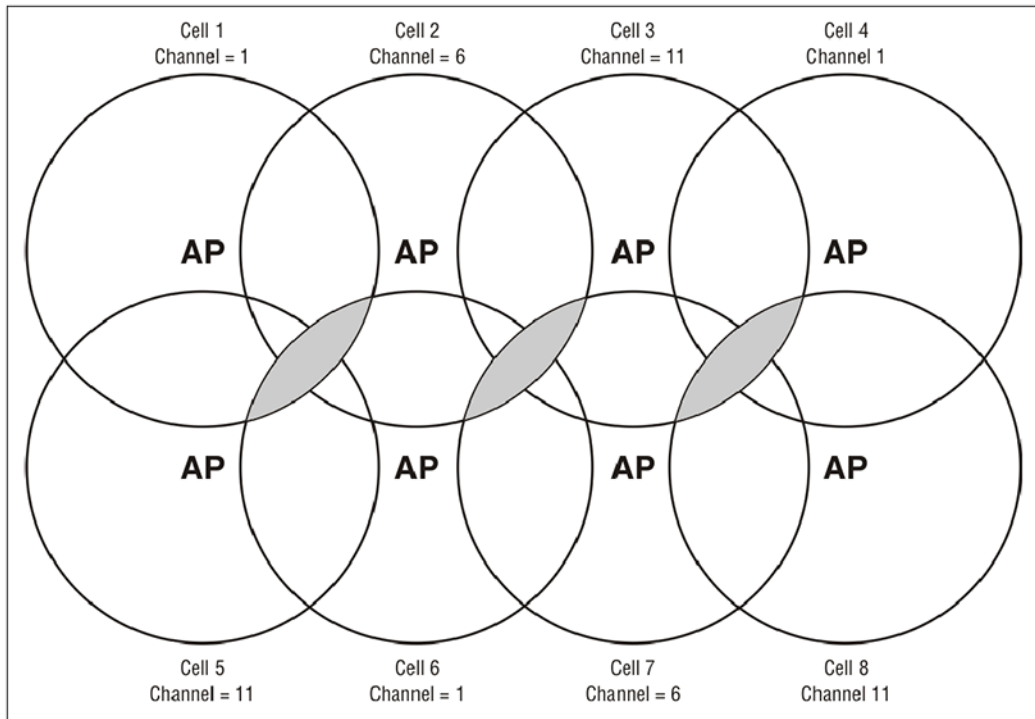

Using three frequencies to cover a large area in North America. Gray areas indicate overlap between two cells that use the same frequency.

Distance between APs

In environments where the number of wireless frequencies is limited, it can be beneficial to adjust the receiver sensitivity of the AP. To make the adjustment, select **Controlled APs >> Radio management > Radio configuration > [radio]** and set the **Distance between access points** option.

For most installations, **Distance between access points** should be set to **Large**. However, if you are installing several wireless APs and the channels available to you do not provide enough separation, reducing receiver sensitivity can help you to reduce the amount of crosstalk between wireless APs.

Another benefit to using reduced settings is that it improves roaming performance. Wireless users switch between APs more frequently.

Automatic transmit power control

The automatic power control feature enables the AP to dynamically adjust its transmission power to avoid causing interference with neighboring HP APs. For information see [“Transmit power control”](#) (page 99).

Supporting 802.11a and legacy wireless clients

The 802.11n standard is very similar to the 802.11g standard, in that both provide mechanisms to support older wireless standards. In the case of 802.11g, protection mechanisms were created to allow 802.11b and 802.11g wireless devices to co-exist on the same frequencies. The data rates of 802.11g (6, 9, 12, 18, 24, 36, 48 and 54 Mbps) are transmitted using Orthogonal Frequency Division Multiplexing (OFDM) modulation, while the data rates of 802.11b are transmitted using Direct Sequence Spread Spectrum (DSSS) modulation. Since older 802.11b-only clients cannot detect OFDM transmissions, 802.11g clients must “protect” their transmissions by first sending a frame using DSSS modulation. This frame – usually a CTS-to-self or RTS/CTS exchange – alerts 802.11b clients to not attempt to transmit for a specified period of time.

If protection is not used, 802.11b clients may transmit a frame while an 802.11g frame is already being sent. This leads to a collision and both devices need to re-transmit. If there are enough

devices in the network, the collision rate will grow exponentially and prevent any useful throughput from the wireless network.

802.11n clients face the same problem as described above – legacy 802.11b clients cannot detect the High Throughput (HT) rates that 802.11n uses. So to avoid causing excessive collisions, 802.11n clients must use the same protection mechanisms when a legacy client is present. Even the most efficient protection mechanism (CTS-to-self) causes a substantial decline in throughput; performance can decline by as much as 50 percent. For this reason, the protection behavior of the HP 425, MSM430, MSM460, MSM466, and MSM466-R can be configured (see [“Tx protection” \(page 98\)](#)) to allow network administrators greater flexibility over their deployments.

NOTE: 802.11n clients can only achieve maximum throughput when legacy clients are not present on the same radio. You can use the **Allow 802.11n clients only** setting to segregate 802.11n traffic to ensure that 802.11n clients do not experience performance degradation by sharing a wireless network with legacy (slower) client stations.

Radio configuration

To define configuration settings for a radio, select **Controller > Controlled APs >> Radio Management > Radio configuration**. This opens the Product radios page which lists all radios on all AP models. For example:

Base Group: All Product radios			
Product	Radio 1	Radio 2	Radio 3
MSM310	AP 802.11b/g (2.4 GHz)	-	-
MSM320	AP 802.11b/g (2.4 GHz)	Monitor 802.11b/g (2.4 GHz)	-
MSM335	AP 802.11b/g (2.4 GHz)	AP 802.11a (5 GHz)	Monitor 802.11b/g (2.4 GHz)
MSM410	AP 802.11n/b/g (2.4 GHz)	-	-
MSM422	AP 802.11n/a (5 GHz)	AP 802.11b/g (2.4 GHz)	-
MSM317	AP 802.11b/g (2.4 GHz)	-	-
MSM430	AP 802.11n/a (5 GHz)	AP 802.11n/b/g (2.4 GHz)	-
MSM460	AP 802.11n/a (5 GHz)	AP 802.11n/b/g (2.4 GHz)	-
MSM466	AP 802.11n/a (5 GHz)	AP 802.11n/b/g (2.4 GHz)	-
MSM466-R	AP 802.11n/a (5 GHz)	AP 802.11n/b/g (2.4 GHz)	-
HP 425	AP 802.11n/a (5 GHz)	AP 802.11n/b/g (2.4 GHz)	-

To configure the radios for a product, select the product in the list. This opens the Radio(s) configuration page. The contents of this page varies depending on the product. The following example shows the Radio(s) configuration page for the MSM466 and MSM466-R.

MSM466 Radios configuration

✓
?

Radio 1

Regulatory domain: **UNITED STATES**

Operating mode: Access point only

Wireless mode: 802.11n/a (5 GHz)

Channel width: Auto 20/40 MHz

Channel: Automatic

*** = DFS Important note**

Interval: Time of Day

Time of day: 01 hh 00 mm

Automatic channel exclusion list: Channel 1, 2.412GHz
Channel 2, 2.417GHz
Channel 3, 2.422GHz

Antenna gain: 2 dBi

Max clients: 255

Advanced wireless settings

Client restriction: Disabled

- Collect statistics for wireless clients
- Tx beamforming
- RTS threshold: bytes
- Spectralink VIEW
- Severe interference detection/mitigation

Tx protection: CTS-to-self

Guard interval: Short

Distance between APs: Large

Beacon interval: 100 time units (TU)

Multicast Tx rate: 6.0 Mb/s

Traffic shaping: Disabled

Transmit power control

Maximum output power: **20 dBm**

- Use maximum power
- Set power to dBm
which is % of max power
- Automatic power control
Interval: hour

Neighborhood scanning

Scan ratio: %

Dwell time: ms

Scanning mode: Passive

Bands to scan: All bands

Channels to scan: All channels

Neighbor detection time: 4218 s

✓
?

Radio 2

Regulatory domain: **UNITED STATES**

Operating mode: Monitor

Wireless mode: 802.11n/b/g (2.4 GHz)

Channel width: 20 MHz

Channel: Automatic

*** = DFS Important note**

Neighborhood scanning

Dwell time: ms

Scanning mode: Passive

Channels to scan: All channels

Radio configuration parameters

This section provides definitions for all configuration parameters that are present on all products.

Regulatory domain

Indicates the geographical region in which the AP is operating. To set the regulatory domain, see [“Assigning country settings to a group” \(page 170\)](#).

Operating mode

Select the operating mode for the radio. Available options are:

- **Access point and Local mesh:** Standard operating mode provides support for all wireless functions. (Not supported on radio 3 on the MSM335.) The total available bandwidth on the radio is shared between all local mesh links and wireless users. This can result in reduced throughput if lots of traffic is being sent by both wireless users and the local mesh links. You can use the QoS feature to prioritize traffic.
- **Access point only:** Only provides AP functionality, local mesh links cannot be created. (Not supported on radio 3 on the MSM335.)
- **Local mesh only:** Only provides local mesh functionality. Wireless client stations cannot connect.
- **Monitor:** Disables AP and local mesh functions. Use this option for continuous scanning across all channels in all wireless modes. See the results of the scans by selecting **Controlled APs >> Security > Neighborhood**.
- **Sensor:** Enables RF sensor functionality on the radio. HP APs are smart APs, and do not forward broadcast packets when no client stations are connected. Therefore, the RF sensor function will not be able to detect these APs unless they have at least one connected wireless client station. This feature requires that the appropriate license is installed on the AP. See [“Managing licenses” \(page 541\)](#).

The following table shows the operating modes supported for each product.

Product	Access point and Local mesh	Access point only	Local mesh only	Monitor	Sensor
MSM310 MSM310-R	✓	✓	✓	✓	×
MSM320 MSM320-R	✓	✓	✓	✓	✓
MSM325	✓	✓	✓	✓	✓
MSM335 (Radio 1 + 2)	✓	✓	✓	✓	✓
MSM335 (Radio 3)	×	×	✓	✓	✓
MSM410	✓	✓	✓	✓	×
MSM422	✓	✓	✓	✓	×
MSM317	×	✓	×	✓	×
HP 425	✓	✓	✓	✓	×
MSM430	✓	✓	✓	✓	×
MSM460	✓	✓	✓	✓	×

Product	Access point and Local mesh	Access point only	Local mesh only	Monitor	Sensor
MSM466 MSM466-R	✓	✓	✓	✓	×
HP 517	×	✓	×	✓	×

The following table shows all radio parameters that are configurable for each operating mode.

Parameter	Access point and Local mesh	Access point only	Local mesh only	Monitor	Sensor
"Regulatory domain" (page 87)	✓	✓	✓	✓	✓
"Wireless mode" (page 89)	✓	✓	✓	✓	×
"Channel width" (page 91)	✓	✓	✓	✓	×
"Channel extension" (page 91)	✓	✓	✓	✓	×
"Channel" (page 92)	✓	✓	✓	✓	×
"Interval" (page 93)	✓	✓	✓	×	×
"Time of day" (page 94)	✓	✓	✓	×	×
"Automatic channel exclusion list" (page 94)	✓	✓	✓	×	×
"Antenna selection" (page 94)	✓	✓	✓	×	✓
"Antenna gain" (page 96)	✓	✓	✓	×	×
"Max clients" (page 96)	✓	✓	✓	×	×
"Client restriction" (page 96)	✓	✓	✓	✓	✓
"Collect statistics for wireless clients" (page 96)	✓	✓	✓	×	×
"Tx beamforming" (page 96)	✓	✓	✓	×	×
"RTS threshold" (page 97)	✓	✓	✓	×	×
"Spectralink VIEW" (page 97)	✓	✓	✓	×	×
"Severe interference detection/mitigation" (page 97)	✓	✓	✓	×	×
"Tx protection" (page 98)	✓	✓	✓	×	×
"Guard interval" (page 98)	✓	✓	✓	×	×
"Maximum range (ack timeout)" (page 98)	✓	×	✓	×	×
"Distance between APs" (page 99)	✓	✓	✓	×	×
"Beacon interval" (page 99)	✓	✓	✓	×	×
"Multicast Tx rate" (page 99)	✓	✓	✓	×	×
"Traffic shaping" (page 99)	✓	✓	✓	×	×

Parameter	Access point and Local mesh	Access point only	Local mesh only	Monitor	Sensor
"Transmit power control" (page 99)	✓	✓	✓	×	×
"Neighborhood scanning" (page 101)	×	✓	×	✓	×

Certain parameters are not supported on all radios. Refer to the parameter descriptions that follow for details.

Wireless mode

Supported wireless modes are determined by the regulations of the country in which the AP is operating, and are controlled by the country setting on the AP. To configure the country setting, see "Assigning country settings to a group" (page 170).

802.11ac/n/a (5 GHz)

Supported on	HP 517
Frequency band	5 GHz
Data rates	<p>For 802.11ac clients: Up to 1300 Mbps.</p> <p>For 802.11n clients: Up to 450 Mbps.</p> <p>For 802.11a clients: Up to 54 Mbps.</p>

When operating in this mode, the AP allows 802.11ac, 802.11n, and 802.11a clients to associate. The AP will dynamically adjust channel width and data rates to individually accommodate the capabilities of each associated wireless client.

802.11n/a (5 GHz)

Supported on	<p>MSM410, MSM466, MSM466-R, HP 517 (not supported in Monitor mode on the HP 517)</p> <p>Radio 1 on: MSM422, HP 425, MSM430, MSM460</p>
Frequency band	5 GHz
Data rates	<p>For 802.11n clients: Up to 450 Mbps on the MSM466, MSM466-R, MSM460, and HP 517, and up to 300 Mbps on the MSM410, MSM422, HP 425, and MSM430.</p> <p>For 802.11a clients: Up to 54 Mbps.</p>

When operating in this mode, the AP allows both 802.11n and legacy 802.11a clients to associate. The AP advertises protection in the beacon when legacy clients are associated or operating on the same channel. This alerts associated 802.11n clients to use protection when transmitting. The AP also uses protection when necessary when sending 802.11n data. The type of protection is configurable by setting the **Tx protection** parameter (except on the HP 517 where Tx protection is not configurable, but is automatically supported using a combination of RTS/CTS and CTS-to-self).

802.11a (5 GHz)

Supported on	MSM310, MSM320, MSM335, MSM410, MSM422, MSM466, HP 517 (not supported in Monitor mode on the HP 517)
---------------------	--

	Radio 1 on: HP 425, MSM430, MSM460 (not supported in Monitor mode)
Frequency band	5 GHz
Data rates	Up to 54 Mbps.

This is a legacy mode that can be used to support older wireless client stations.

802.11n/b/g (2.4 GHz)

Supported on	MSM410, MSM422, HP 517 Radio 2 on: HP 425, MSM430, MSM460, MSM466
Frequency band	2.4 GHz
Data rates	For 802.11n clients: Up to 130 Mbps on the MSM410, MSM422, HP 425, MSM430, MSM460, MSM466, MSM466-R. (Up to 300 Mbps when using a 40 MHz channel width, which is not recommended in the 2.4 GHz frequency band.) Up to 216.7 Mbps on the HP 517. For 802.11g clients: Up to 54 Mbps.. For 802.11b clients: Up to 11 Mbps.

When operating in this mode, the AP allows both 802.11n and legacy 802.11b/g clients to associate. The AP advertises protection in the beacon when legacy clients are associated or operating on the same channel. This alerts associated 802.11n clients to use protection when transmitting. The AP also uses protection when necessary when sending 802.11n data. The type of protection is configurable by setting the **Tx protection** parameter (except on the MP 517 where Tx protection is not configurable, but is automatically supported using a combination of RTS/CTS and CTS-to-self).

802.11b/g (2.4 GHz)

Supported on	MSM310, MSM317, MSM320, MSM335, MSM410, MSM422, HP 517 (not supported in Monitor mode on the HP 517) Radio 2 on: HP 425, MSM430, MSM460, MSM466 (not supported in Monitor mode on the HP 425)
Frequency band	2.4 GHz
Data rates	For 802.11g clients: Up to 54 Mbps. For 802.11b clients: Up to 11 Mbps.

This is a legacy mode that can be used to support older wireless client stations.

802.11g (2.4 GHz)

Supported on	MSM310, MSM320, MSM335
Frequency band	2.4 GHz
Data rates	Up to 54 Mbps.

This is a legacy mode that can be used to support older wireless client stations.

802.11b (2.4 GHz)

Supported on	MSM310, MSM317, MSM320, MSM335
Frequency band	2.4 GHz
Data rates	Up to 11 Mbps.

This is a legacy mode that can be used to support older wireless client stations.

802.11a Turbo

Supported on	MSM310, MSM320, MSM335
Frequency band	5 GHz
Data rates	Up to 108 Mbps.

Provides channel bonding in the 5 GHz frequency band for enhanced performance. Useful to provide increased throughput when creating local mesh links between two APs.

Channel width

Supported on: MSM410, MSM422 (radio 1), HP 425, MSM430, MSM460, MSM466, MSM466-R, HP 517

Not available in Monitor or Sensor modes.

802.11n allows for the use of the standard channel width of 20 MHz, or a double width of 40 MHz. The double width is achieved by using two adjacent channels to send data simultaneously. This results in double the available bandwidth leading to much higher throughput.

802.11ac allows for the use of the standard channel width of 20 MHz, a double width of 40 MHz, or a quad width of 80 MHz. The double width is achieved by using two adjacent channels to send data simultaneously. The quad width is achieved by using four adjacent channels.

Select the **Channel width** from one of the following options:

- **20 MHz:** Uses the standard channel width of 20 MHz. Recommended when the AP is operating in the 2.4 GHz band and multiple networks must co-exist in the same location.
- **Auto 20/40 MHz:** The AP will advertise 40 MHz support to clients, but will use 20 MHz for each client that does not support 40 MHz.
- **Auto 20/40/80 MHz:** (Only supported when **Wireless mode** is set to 802.11ac/n/a on the HP 517.) The AP automatically adjusts channel width to support clients that are using 20, 40, or 80 MHz wide channels.

NOTE: When operating in the 2.4 GHz band, the HP 425, MSM430, MSM460, MSM466, and MSM466-R will automatically switch to using a 20 MHz channel width if a legacy 802.11b/g client or AP is detected on the primary or secondary channel. When the legacy device is no longer present, the AP will revert back to using a 40 MHz channel width.

On the HP 517, when **Wireless mode** is set to **802.11n/b/g**, **Channel width** is automatically set to **20 MHz** and cannot be changed.

Channel extension

Supported on: MSM410, MSM422 (radio 1), HP 425 (radio 2), MSM430 (radio 2), MSM460 (radio 2), MSM466 (radio 2), MSM466-R (radio 2)

Not available in Sensor mode.

This setting only appears when **Wireless mode** is set to **802.11n/b/g** and **Channel width** is set to **Auto 20/40 MHz**.

This setting determines where the second 20 MHz channel is located.

- **Above the beacon (+1):** The secondary channel is located on a channel above the currently selected channel.
- **Below the beacon (-1):** The secondary channel is located on a channel below the currently selected channel.

Channel

Select channel (frequency) for wireless services. The channels that are available are determined by the radio installed in the AP and the regulations that apply in your country.

Automatic channel selection

Use the **Automatic** option to have the AP select the best available channel. Control how often the channel selection is re-evaluated by setting the **Interval** parameter. If the **Interval** parameter is set to any value other than **Time of day**, and a wireless client is associated with the radio, automatic channel selection is delayed. The AP will retry at one minute intervals until the radio is unused by wireless clients.

- **On the HP 425, MSM430, MSM460, MSM466, MSM466-R, HP 517:** Scanning during the channel selection process can cause interruptions to voice calls. This only occurs each time the Interval expires. Therefore, HP does not recommend configuring a short **Interval**.
- **On the MSM310, MSM320, MSM335, MSM410, MSM422:** Scanning is continuously performed on all the channels in the currently selected **Operating mode**, even though the channel is only re-evaluated each time the **Interval** expires. (If **Interval** is set to **Disabled**, continuous scanning is not performed.) Continuous scanning can cause interruptions to voice calls. On dual-radio APs, you can avoid interruptions by setting one radio to operate in Monitor mode. For example, if radio 1 is set to **Automatic** and radio 2 is in **Monitor** mode, scanning occurs on radio 2 and interruptions on radio 1 do not occur.

CAUTION: When using the **Automatic** option with an external antenna in the 2.4 GHz band, all channels must be set to the lowest acceptable value for your regulatory domain. See [“Transmit power control” \(page 99\)](#).

Manual channel selection

If setting the channel manually, for optimal performance when operating in 2.4 GHz modes, select a channel that differs from other wireless APs operating in neighboring cells by at least 25 MHz. For example, if another AP is operating on channel 1, set the AP to channel 6 or higher.

When operating in 802.11a or 802.11n (5 GHz) modes, channels do not interfere with each other, enabling APs to operate on two adjacent channels without interference.

HP APs support Dynamic Frequency Selection (802.11h) and Transmit Power Control (802.11d) for 802.11a operation in European countries. These options are automatically enabled as required. Channels used by dynamic frequency selection (DFS) for radar avoidance, are identified with an asterisk "*".

- **On the MSM410, MSM422 (radio 1), HP 425, MSM430, MSM460, MSM466, MSM466-R:** When **Wireless mode** is **802.11n/a** and **Channel width** is **Auto 20/40 MHz**, the channel numbers in the **Channel** list include either a **(1)** or **(-1)** to their right. A **(1)** indicates that the 40

MHz channel is formed from the indicated channel plus the next channel. A **(-1)** indicates that the 40 MHz channel is formed from the indicated channel plus the previous channel.

With a 40 MHz Channel width in the 5 GHz band, channel selection and usage is as follows for the first four channels:

Channel selected	Channels used
36(1)	36+40
40(-1)	40+36
44(1)	44+48
48(-1)	48+44

NOTE: The channel selected is the primary channel and the channel above or below it becomes the secondary channel. The AP beacon is transmitted only on the primary channel and all legacy client traffic is carried on the primary channel.

- **On the MSM410, MSM422 (radio 1):** When **Wireless mode** is **802.11n/b/g**, and **Channel width** is **Auto 20/40 MHz**, the **Channel extension** parameter value affects which channels are shown in the Channel list. Although HP recommends that you use the 5 GHz band for all 802.11n activity, if you insist upon using 802.11n and a 40 MHz **Channel width** in the crowded 2.4 GHz band, it is best to select channels as follows, according to the number of 2.4 GHz channels available in your region.

Available 2.4 GHz channels	Channel width	Recommended non-overlapping channels
1 to 13	20 MHz	1, 7, 13
1 to 13	40 MHz	1, 13 (If both are used, there will be some performance degradation.)
1 to 11	20 MHz	1, 6, 11
1 to 11	40 MHz	1, 11 (If both are used, there will be some performance degradation.)

- When using an 80 MHz channel width on the HP 517, the primary channel can be any one of the channels in the following sets, with the remaining channels in the set becoming secondary channels.
 - 36, 40, 44, 48
 - 52, 56, 60, 64
 - 100, 104, 108, 112
 - 116, 120, 124, 128
 - 132, 136, 140, 144
 - 149, 153, 157, 161

Interval

Not available in Monitor or Sensor modes, or when the auto-channel feature is enabled.

When the **Automatic** option is selected for **Channel**, this parameter determines how often the AP re-evaluates the channel setting. Select **Time of day** to have the channel setting re-evaluated at a specific time of day.

- Select **Time of day** to have the channel setting re-evaluated at a specific time of day. Note that to prevent all APs from re-evaluating their channel at the same time, a random delay between 0 and 2 hours is added to the time of day for each AP. If the **Interval** parameter is set to any value other than **Time of day**, and a wireless client is associated with the radio, automatic channel selection is delayed. The AP will retry at one minute intervals until the radio is unused by wireless clients.
- Select **a time interval** in hours to define how often the channel setting is re-evaluated. If a wireless client is associated with the radio when the interval occurs, automatic channel selection is delayed (at one minute intervals) until the radio is unused by wireless clients. Background scanning is not supported when you select this option.
- Select **Disabled** to have the scan performed once when you select **Save**, and then only when the AP is restarted. This also prevents continuous scanning from being performed on the MSM310, MSM320, MSM335, MSM410, and MSM422.

Time of day

Not available in Monitor or Sensor modes, or when the auto-channel feature is enabled.

When the **Time of day** option is selected for **Interval**, this parameter determines the time of day that the AP re-evaluates the channel setting.

To prevent APs from re-evaluating their channel at the same time, a random delay between 0 and 2 hours is added to the time of day for each AP. For example, if 1AM is selected, the channel will be re-evaluated between 1AM and 3AM.

Automatic channel exclusion list

Not available in Monitor or Sensor modes, or when the auto-channel feature is enabled.

Used when **Automatic** is selected under **Channel**, this parameter determines the channels that are not available for automatic selection. To select more than one channel, hold down **Ctrl** as you select the channel names.

On the HP 517, channel 144 is excluded by default.

Antenna selection

Supported on: MSM310, HP 425, MSM320, MSM335, MSM422

Not available in Monitor or Sensor modes.

Select the antenna(s) to use for each radio. Antenna support varies on each AP. For a list of supported external antennas, see *Connecting external antennas* in the *MSM3xx / MSM4xx Access Points Configuration Guide*.

In most APs, antenna diversity is supported. Diversity provides improved signal quality by using multiple antennas on the same radio.

NOTE:

- When using an external antenna, it is your responsibility to make sure that the radio does not exceed the transmit power level for the country of use. See [“Transmit power control” \(page 99\)](#).
 - When creating a point-to-point local mesh link, HP recommends that you use an external directional antenna.
-

MSM310, MSM310-R, and MSM320

Select **Diversity**, **Main**, or **Auxiliary** according to the following guidelines:

- For a single antenna, connect one antenna to either Main or Aux and select the corresponding value.
- For maximum wireless coverage, install an omnidirectional antenna on the Main and Aux antenna connectors and select **Diversity**.
- When creating a point-to-point wireless bridge, HP recommends that a single directional antenna be used on either Main or Aux.

MSM320-R

Only two antenna connectors are available on the MSM320-R. To use both radios, connect an antenna to each connector. Diversity is not supported.

MSM335

Select either **Internal** or **External** according to the following guidelines:

- The MSM335 features six internal antennas in its two flaps, providing two antennas for each of its three radios. Radios 1, 2, and 3, have corresponding external antenna connectors A, B, and C for optional external antennas.
- Diversity is supported on all three radios via the internal antennas. but not when using external antennas.

MSM422

Select either **Internal** or **External** according to the following guidelines:

Radio 1

- Radio 1 features three internal antennas in the lower flap supporting 802.11n/a/b/g. Each antenna has a corresponding connector (A, B, C) for the installation of an optional external antenna.
- Radio 1 supports diversity on its internal and external antennas. In 802.11n modes, a special form of diversity, called MIMO, is used.
MIMO uses spatial multiplexing to transport two or more data streams simultaneously on the same channel to increase throughput. For example, under most conditions, multiplexing two streams can result in double the throughput of a single stream.
MIMO mode 3x3 is automatically used, which means that three antennas are used to transmit and three antennas are used to receive.
- For point-to-point local mesh links on Radio 1, install two directional antennas on connectors A and B. Installing a third directional antenna on connector C will increase performance only when receiving.

Radio 2

- Radio 2 features two internal antennas in the upper flap supporting 802.11 a/b/g. These antennas have a single connector (D) for the installation of an optional external antenna.
- Radio 2 provides support for diversity only on its two internal antennas. Diversity is not supported when using an external antenna.

HP 425

Select the antenna(s) on which the radio transmits and receives.

Both radios support diversity (MIMO) on both internal and external antennas.

MIMO uses spatial multiplexing to transport two or more data streams simultaneously on the same channel to increase throughput. For example, under most conditions, multiplexing two streams can result in double the throughput of a single stream.

MIMO mode 2x2 is automatically used, which means that both antennas (either internal or external) are used to transmit and receive the spatial streams.

Antenna gain

Supported on: MSM310, MSM310-R, MSM320, MSM320-R, MSM466, MSM466-R, and HP 425 (when an external antenna is selected).

Not available in Monitor or Sensor modes.

For optimum performance, this parameter must be set to the gain of the antenna.

Max clients

Not available in Monitor or Sensor modes.

Specify the maximum number of wireless client stations that can be supported on this radio across all VSCs.

Advanced wireless settings

Client restriction

*Only available when **Wireless mode** supports 802.11ac or 802.11n.*

Use this option to restrict access to the wireless network to specific types of wireless clients.

- **802.11n only:** Only wireless clients supporting 802.11n can connect. This prevents 802.11a/b/g client stations from accessing the wireless network.
- **802.11ac only:** Only wireless clients supporting 802.11ac can connect. (HP 517 only)
- **802.11ac or 802.11n only:** Only wireless clients supporting 802.11ac or 802.11n can connect. (HP 517 only).

Collect statistics for wireless clients

Not available in Monitor or Sensor modes.

When this option is enabled, the AP collects statistics for connected wireless client stations. The statistical information can be retrieved via SNMP from the following MIBs:

MIB	Table
COLUBRIS-DEVICE-WIRELESS-MIB.my(controlled mode)	coDeviceWirelessDetectedStationTable
COLUBRIS-IEEE802DOT11.my(autonomous mode)	coDot11DetectedStationTable

Tx beamforming

Supported on: MSM430, MSM460, MSM466, MSM466-R

Not available in Monitor or Sensor modes.

Tx beamforming can be used to help increase throughput by improving the quality of the signal sent to wireless clients

When this option is enabled, APs use beamforming techniques to optimize the signal strength for each individual wireless client station. Beamforming works by changing the characteristics of the transmitter to create a focused beam that can be more optimally received by a wireless station.

HP APs support the following two explicit beamforming techniques:

- Non-compressed beamforming, in which the client station calculates and sends the steering matrix to the AP.
- Compressed beamforming, in which the client station sends a compressed steering matrix to the AP.

Radio calibration is not required to use either of these two methods.

NOTE: Beamforming only works with wireless clients that are configured to support it.

RTS threshold

Not available in Monitor or Sensor modes.

Use this parameter to control collisions on the link that can reduce throughput. If the **Controlled APs > [group] [AP] >> Status > Wireless** page shows increasing values for **Tx multiple retry frames** or **Tx single retry frames**, adjust this value until the errors clear. Start with a value of 1024 and decrease to 512 until errors are reduced or eliminated. Note that using a small value for **RTS threshold** can affect throughput. Range: 128 to 1540.

If a packet is larger than the threshold, the AP holds the packet and issues a request to send (RTS) message to the client station. The AP sends the packet only when the client station replies with a clear to send (CTS) message. Packets smaller than the threshold are transmitted without this handshake.

Spectralink VIEW

Supported on: MSM310, MSM320, MSM335, MSM410, MSM422, HP 425, MSM430, MSM460, MSM466, MSM466-R

Not available in Monitor or Sensor modes.

Provides support for Spectralink phones using Spectralink Voice Interoperability for Enterprise Wireless (VIEW) extensions.

Severe interference detection/mitigation

Supported on: MSM410, HP 425, MSM430, MSM460, MSM466, MSM466-R

Not available in Monitor or Sensor modes.

When enabled, the radio maintains channel-quality information for all potential operating channels. The information for the current operating channel is derived using performance statistics (packet retry rates, error rates, per-client data-rates), beacons received from in-channel neighbor APs, spectrum analysis samples, etc.

When an AP detects a severe degradation in the channel quality of the current operating channel on a radio (that persists for tens of seconds), the AP informs the controller that it is experiencing severe channel interference and wants to initiate a channel change.

Before doing this, the AP does an intensive spectrum analysis scan to identify the type of interference. This information is included in the report to the controller. The controller responds to the AP and provides it with a prioritized list of alternative channels that are optimal from a system-wide perspective. The AP does a quick check of each channel in priority order to verify that interference is not present. Assuming a new channel is usable, the AP initiates a channel switch to the alternate channel. The AP then informs the controller that it has switched channels. After switching to an alternative channel, the AP continues to monitor the channel quality of the non-operating channels.

Eventually, it is expected that the interference will go away. (Most interference sources are temporary.) At this point the AP informs the controller that the original channel is clear. The controller then decides whether the AP should switch back to the original channel or continue operating on the alternate channel.

Tx protection

Supported on: MSM410, HP 425, MSM430, MSM460, MSM466, MSM466-R

Not available in Monitor or Sensor modes.

When an AP is operating in an 802.11n mode, and legacy (a/b/g) traffic is present on the same channel as 802.11n traffic, this feature can be used to ensure maximum 802.11n throughput.

The following options are available:

- **CTS-to-self:** 802.11n transmissions are protected by sending a Clear To Send (CTS) frame that blocks other wireless clients from accessing the wireless network.
- **RTS/CTS:** 802.11n transmissions are protected by sending a Request To Send (RTS) frame followed by a CTS frame. This is a more robust, but slower, solution than CTS-to-self. However, this method resolves the hidden station problem (where certain legacy stations may not see only a CTS frame).
- **No MAC protection:** This setting gives the best performance for 802.11n clients in the presence of 802.11g or 802.11a legacy clients or APs. No protection frames (CTS-to-self or RTS/CTS) are sent at the MAC layer by the AP. PHY-based protection remains active, which alerts legacy clients to stay off the air while the AP is transmitting data to 802.11n clients. This method of protection is supported by most 802.11g or 802.11a clients, but is not supported for 802.11b-only clients and should not be used if such clients are expected on the network.

Guard interval

Supported on: MSM410, MSM422 (radio 1), HP 425, MSM430, MSM460, MSM466, MSM466-R

Not available in Monitor or Sensor modes.

This parameter is only configurable when **Wireless mode** is set to support an 802.11n option.

On the MSM410 and MSM422, **Guard interval** is automatically set to **Long** when **Channel width** is set to **20 MHz**. Guard interval is not configurable on the HP 517. It is always set to **Short**, but will downgrade to **Long** based on the capability of connected clients or the wireless environment.

To enhance performance in 802.11n modes, the guard interval can be reduced from its default of 800 nanoseconds to 400.

The guard interval is the intersymbol time period that is used to prevent symbol interference when multiple data streams are used (MIMO). However, symbol interference reduces the effective SNR of the link, so reducing the guard interval may not improve performance under all conditions.

The following settings are available:

- **Short:** Sets the guard interval to 400 nanoseconds which can provide improved throughput (up to 10%) in some environments. The AP remains compatible with clients that only support a long guard interval. Use this setting when **Channel width** is set to **Auto 20/40 MHz** to get the best throughput.
- **Long:** Sets the guard interval to the standard of 800 nanoseconds.

Maximum range (ack timeout)

Only available in modes that support Local Mesh.

Fine tunes internal timeout settings to account for the distance that a link spans. For normal operation, timeout is optimized for links of less than 1 km.

NOTE: This is a global setting that applies to all wireless connection made with the radio. Therefore, adjusting this setting may lower the performance for users with marginal signal strength or when interference is present. (Essentially, it means that if a frame needs to be retransmitted it will take longer before the actual retransmit takes place.)

Distance between APs

Not available in Monitor or Sensor modes.

Use this parameter to adjust the receiver sensitivity of the AP only if you have a very dense deployment where many APs are close together. In all other cases, use the default setting of **Large**. If you have installed multiple APs, reducing the receiver sensitivity helps to keep clients with low signal quality from connecting, thereby increasing the probability that client stations connect with the nearest AP.

Available settings

- **Large:** Accepts all clients.
- **Medium:** Accepts clients with an RSSI greater than 15 dB.
- **Small:** Accepts clients with an RSSI greater than 20 dB.

NOTE: RSSI (Received Signal Strength Indication) is the difference between the amount of noise in an environment and the wireless signal strength. It is expressed in decibels (dB). The higher the number the stronger the signal.

Beacon interval

Not available in Monitor or Sensor modes.

Sets the number of time units (TUs) that the AP waits between transmissions of the wireless beacon. One TU equals 1024 microseconds. The default interval is 100 TU, which is equal to 102.4 milliseconds. Supported range is from 20 to 500 TU.

Multicast Tx rate

Not available in Monitor or Sensor modes.

Use this parameter to set the transmit rate for multicast and broadcast traffic. This is a fixed rate, which means that if a station is too far away to receive traffic at this rate, the multicast is not seen by the station.

Traffic shaping

Not available in Monitor or Sensor modes.

(Only available on the MSM410, HP 425, MSM430, MSM460, MSM466, and MSM466-R.)

Use this parameter to define how wireless air time is shared between client stations. Traffic shaping applies to all client stations connected to all VSCs that use this radio.

- **Disabled:** Traffic shaping is off.
- **Airtime fairness:** The AP attempts to provide each client with an equal share of wireless time. Both transmit and receive times are considered. Airtime fairness is QoS-aware.

Transmit power control

Not available in Monitor or Sensor modes.

Use these parameters to control the transmission power of the wireless radio.

Adjustments to the transmission power may be required for two reasons. First, when using an optional external antenna, it may be necessary to reduce power levels to remain in compliance with local regulations. Second, it may be necessary to reduce power levels to avoid interference between APs and other radio devices.

Important

For a list of supported external antennas, see *Connecting external antennas* in the *MSM3xx / MSM4xx Access Points Configuration Guide*.

When using antennas not originally supplied with the AP, it is your responsibility to ensure that the **Transmit power control** settings are configured so that the radio will not exceed permissible power levels for the regulatory domain in which the AP is operating. Depending on the regulatory domain, the specific antenna chosen, the wireless mode, channel width, band or channel selected, you may need to configure the radio with a reduced transmit power setting. When using **Automatic channel selection** with an external antenna in the 2.4 GHz band, all channels must be set to the lowest acceptable value for your regulatory domain.

CAUTION: For specific power limits according to your regulatory domain, consult the *Antenna Power-Level Settings Guide* available at www.hp.com/support/manuals. Search for the part number of your antenna.

For example, if you install an external 8 dBi directional antenna, and the maximum allowed power level for your country is 15 dBm, you may have to reduce the transmit power level to be in compliance.

If you change the antenna at a later time, you must get the latest version of the *Antenna Power-Level Settings Guide*, and again reassess and possibly adjust radio power settings according to the antenna used.

When setting **Transmit power control** to comply with information in the *Antenna Power-Level Settings Guide*, always set radio power in dBm, and not as a percentage.

Maximum output power

Shows the maximum output power that can be supported by the radio based on the regulatory domain.

- **On the MSM410, MSM430, and MSM460MSM317:** Shows the maximum EIRP (Effective/Equivalent Isotropic Radiated Power) that can be delivered by the AP based on the regulatory domain. The displayed EIRP power is equivalent to the Conducted RF transmit power of the radio (dBm) plus the array gain of the antenna (dBi). EIRP is only displayed on the HP 425 when using internal antennas.
- **On the MSM466 and MSM466-R:** Shows the maximum conducted RF power (dBm) that can be delivered to the external antenna. The EIRP can be calculated by adding the antenna array gain (dBi).

Use maximum power

Select this checkbox to use the maximum available output power.

Set power to

Specify the transmission power in dBm or as a percentage of the maximum output power. When you click **Save**, percentage values are rounded up or down so that the dBm value is always a whole number.

Note that the actual transmit power used by the radio may be less than the specified value. The AP determines the maximum power to be used based on the regulatory domain.

Supported power levels are as follows:

- 0 - 20 dBm: MSM310, MSM317, MSM320, MSM335, MSM410, MSM422, MSM466, MSM466-R
- 5 - 25 dBm: MSM430, MSM460 operating at 2.4 GHz.
- 7 - 20 dBm: MSM430, MSM460 operating at 5 GHz.
- 4 - 27 dBm: HP 425 operating at 2.4 GHz.
- 5 - 28 dBm: HP 425 operating at 5 GHz.

- 15 - 29 dBm: HP 517 operating at 2.4 GHz.
- 16 - 28 dBm: HP 517 operating at 5 GHz.

Automatic power control

Select this checkbox to have the AP automatically determine the optimal power setting within the defined power limits (i.e., up to the specified percentage/dBm value).

Interval

Specify the interval at which the **Automatic power control** feature adjusts the optimal power setting.

Neighborhood scanning

Supported on: MSM410, HP 425, MSM430, MSM460, MSM466, MSM466-R, HP 517

*Not configurable when **Operating mode** is set to **Access point and Local mesh** or **Local mesh only**.*

These settings let you fine-tune the scanning operation used for RRM (“[Radio Resource Management](#)” (page 182)) and IDS (“[Intrusion detection system \(IDS\)](#)” (page 196)).

Scan ratio

(Not configurable when **Operating mode** is set to **Monitor**.)

The percentage of time the radio will spend scanning channels other than the operating channel.

Dwell time

The amount of time (in milliseconds) that a radio remains on a channel while performing channel scanning. The default value is 30 milliseconds. On the HP 517, the minimum value and default setting is 32 milliseconds.

Set a value between 10 and 32 milliseconds when **Operating mode** is set to **Access point only**. (Use a value of 30 milliseconds on the MSM410.)

Set a value between 10 and 1000 milliseconds when **Operating mode** is set to **Monitor**.

Scanning mode

- **Passive:** The AP listens to the channel to detect wireless traffic, but does not transmit any probes. The AP will receive beacon frames and probe response frames, and use them to identify neighbors. (When IDS is enabled, other frames are also received and sent to the IDS system for analysis.) The key point is that no frames are transmitted. This is the default setting.
- **Active:** The AP uses probe request frames to speed up neighbor detection. Active scanning only occurs on channels permitted by the regulatory domain. Transmission of probes is not allowed on DFS channels, so no probes are sent on DFS channels even when this option is selected.

Bands to scan

(Not configurable in **Monitor mode**. The **All bands** option is automatically used.)

(Not supported on the HP 425 and HP 517.)

- **All bands:** Scan both 802.11 bands (2.4 GHz and 5 GHz).
- **Operating band only:** Scan only the band in which the radio is currently operating.

Recommended settings for single radio APs:

- With IDS disabled, select **Operating band only**.
- With IDS enabled, select **All bands**.

Recommended settings for dual radio APs:

- With IDS disabled, configure both radios for **Operating band only**.
- With IDS enabled, configure the 2.4 GHz radio for **Operating band only** (with a small scan ratio), and configure the 5 GHz radio for **All bands** (with a larger scan ratio). The 2.4 GHz band is probably much busier than the 5 GHz band, so IDS scanning using the 5 GHz radio has a reduced performance impact.

Channels to scan

- **All channels:** Scan all channels supported by the current operating mode.
- **Regulatory channels only:** Scan only channels supported by the current regulatory domain (country).
- **Non-excluded channels only:** When enabled, the AP will not scan any channels in the **Automatic channel exclusion list**.

Neighbor detection time

Estimated time in seconds to detect a neighbor.

Viewing wireless information

Viewing all wireless clients

To view information on all wireless client stations, select **Controlled APs >> Overview > Wireless clients**.

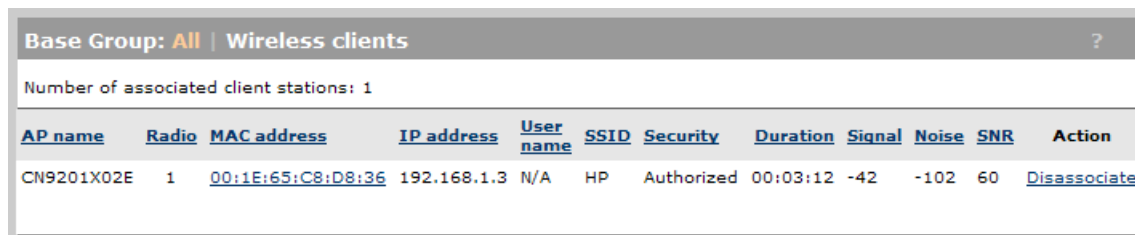

The screenshot shows a web interface for viewing wireless clients. At the top, it says "Base Group: All | Wireless clients" with a help icon. Below that, it indicates "Number of associated client stations: 1". A table follows with columns: AP name, Radio, MAC address, IP address, User name, SSID, Security, Duration, Signal, Noise, SNR, and Action. One row is visible with the following data: AP name CN9201X02E, Radio 1, MAC address 00:1E:65:C8:D8:36, IP address 192.168.1.3, User name N/A, SSID HP, Security Authorized, Duration 00:03:12, Signal -42, Noise -102, SNR 60, and Action Disassociate.

AP name	Radio	MAC address	IP address	User name	SSID	Security	Duration	Signal	Noise	SNR	Action
CN9201X02E	1	00:1E:65:C8:D8:36	192.168.1.3	N/A	HP	Authorized	00:03:12	-42	-102	60	Disassociate

This page lists all wireless clients associated with all VSCs.

Settings

AP name

Name of the AP the with which the client station is associated.

Radio

Radio on the AP that the client station is using.

MAC Address

MAC address of the client station. Select the MAC address to view more detailed information on the client.

IP address

IP address assigned to the client station.

Username

Name with which the user logged in.

SSID

SSID assigned to the client station.

Security

Indicates if the client station has been authorized.

Duration

Indicates how long the client station has been authorized.

Signal

Indicates the strength of the radio signal received from client stations. Signal strength is expressed in decibel milliwatt (dBm). The higher the number the stronger the signal.

Noise

Indicates how much background noise exists in the signal path between client stations and the AP. Noise is expressed in decibel milliwatt (dBm). The lower (more negative) the value, the weaker the noise.

SNR

Indicates the relative strength of the client station radio signals versus the radio interference (noise) in the radio signal path.

In most environments, SNR is a good indicator for the quality of the radio link between the client stations and the AP. A higher SNR value means a better quality radio link.

Action

Select **Disassociate** to disconnect a wireless client.

Viewing info for a specific wireless client

To view information on a specific wireless client station, select **Controlled APs >> Overview > Wireless clients**, and then in the table, select the MAC address of the client.

The information you see will vary depending on the AP to which the client is connected. For example, the following shows the status page for a client connected to an MSM317.

AP: CN9201X02E Wireless client status		Statistics			
Wi-Fi		Bytes Rx:	489431	Bytes Tx:	1824456
Radio:	1	Packets Rx:	5652	Packets Tx:	4657
MAC:	00:1E:65:C8:D8:36	Duration:	00:35:53		
BSSID:	00:24:A8:4B:B1:C0				
Previous AP name:	N/A	Rate	Rx Packets	Tx Packets	
Previous AP BSSID:	FF:FF:FF:FF:FF:FF	1 Mbps	2108	3	
Wireless mode:	802.11g	2 Mbps	0	0	
Signal level:	-41	5.5 Mbps	0	0	
Noise level:	-102	11 Mbps	0	0	
SNR:	61	6 Mbps	0	0	
Last Tx Rate:	54 Mbps	9 Mbps	0	0	
Last Rx Rate:	54 Mbps	12 Mbps	0	0	
Power save state:	Off	18 Mbps	0	0	
Management		24 Mbps	2	0	
SSID:	HP	36 Mbps	6	28	
IP address:	192.168.1.3	48 Mbps	91	28	
WMM:	Yes	54 Mbps	5613	4619	
VLAN:	None	View this client's event log .			
Security					
Authorized:	Yes				
802.1x Authenticated:	No				
MAC Authenticated:	No				
MAC filtered:	No				
WPA:	no WPA				
Terminated at the controller:	No				

For a complete description of all fields see the online help.

Viewing wireless client data rates

To view information on all wireless client stations currently connected to the AP, select **Controlled APs >> Overview > Wireless rates**.

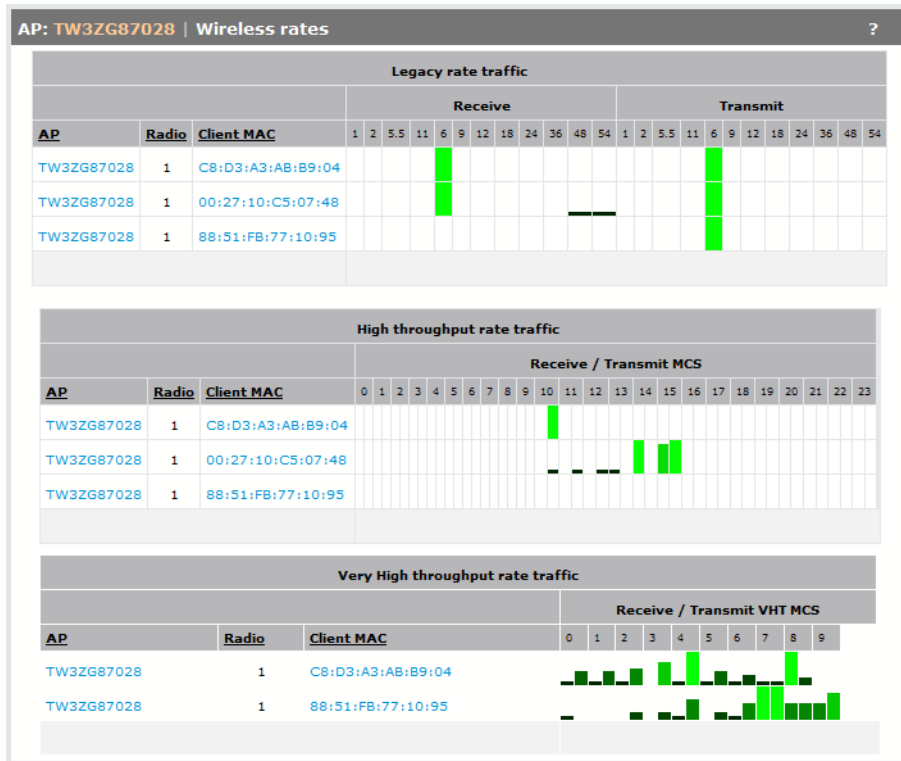

This page shows the volume of traffic sent and received at each data rate for each client station. Headings in bold indicate the data rates that are currently active for the wireless mode being used. Supported wireless rates depend on the AP model.

Legacy rate traffic

Displays information for users connected via any 802.11 a/b/g mode. The size of the bar indicates the amount of traffic sent or received at each rate.

High throughput (HT) rate traffic

Displays information for users connected via any 802.11n mode. Rates are shown for each supported MCS (modulation coding scheme). The size of the bar indicates the amount of traffic sent or received at each MCS.

MCS	Data rates in Mbps			
	Channel width / Guard interval			
	20 MHz/ 800 ns	20 MHz/ 400 ns	40 MHz/ 800 ns	40 MHz/ 400 ns
0	6.50	7.20	13.50	15.00
1	13.00	14.4	47.00	30.00
2	19.50	21.70	40.50	45.00
3	26.00	28.90	54.00	60.00
4	39.00	43.30	81.00	90.00
5	52.00	57.80	108.00	120.00
6	58.50	65.00	121.50	135.00
7	65.00	72.20	135.00	150.00
8	13.00	14.40	27.00	30.00

MCS	Data rates in Mbps			
	Channel width / Guard interval			
	20 MHz/ 800 ns	20 MHz/ 400 ns	40 MHz/ 800 ns	40 MHz/ 400 ns
9	26.00	28.90	54.00	60.00
10	39.00	43.30	81.00	90.00
11	52.00	57.80	108.00	120.00
12	78.00	86.70	162.00	180.00
13	104.00	115.6	216.00	240.00
14	117.00	130.00	243.00	270.00
15	130.00	144.40	270.00	300.00
16	19.50	21.70	40.50	45.00
17	39.00	43.30	81.00	90.00
18	58.50	65.00	121.50	135.00
19	78.00	86.70	162.00	180.00
20	117.00	144.40	243.00	270.00
21	156.00	173.30	324.00	360.00
22	175.50	195.00	364.50	405.00
23	195.00	216.70	405.00	450.00

- MHz = megahertz
- ns = nanoseconds
- MCS 0 to MCS 15 are supported by the MSM410, MSM422, HP 425, MSM430, MSM460, MSM466, MSM466-R, and HP 517.
- MCS 16 to MCS 23 are supported by the MSM460, MSM466, MSM466-R, and HP 517.
- On the HP 517, the guard interval is not configurable. It is always set to 400 ns, but will downgrade to 800 ns based on the capability of connected clients or the wireless environment.
- For HT traffic, the MCS rate implies the number of spatial streams:
 - MCS 0 to 7: 1 spacial stream
 - MCS 8 to 15: 2 spacial stream
 - MCS 16 to 23: 3 spacial stream

Very high throughput rate traffic

Displays information for users connected via 802.11ac. Rates are shown for each supported modulation coding scheme (MCS). The size of the bar indicates the amount of traffic sent at each MCS.

Supported rates vary depending as follows:

One spatial stream

MCS	Data rates in Mbps - Nss=1					
	Channel width / Guard interval					
	20 MHz/ 800 ns	20 MHz/ 400 ns	40 MHz/ 800 ns	40 MHz/ 400 ns	80 MHz/ 800 ns	80 MHz/ 400 ns
0	6.50	7.20	13.50	15.00	29.3	32.5
1	13.00	14.4	47.00	30.00	58.5	65
2	19.50	21.70	40.50	45.00	87.8	97.5
3	26.00	28.90	54.00	60.00	117	130
4	39.00	43.30	81.00	90.00	175.5	195
5	52.00	57.80	108.00	120.00	234	260
6	58.50	65.00	121.50	135.00	263.3	292.5
7	65.00	72.20	135.00	150.00	292.5	325
8	13.00	14.40	27.00	30.00	351	390
9	26.00	28.90	54.00	60.00	390	433.3

Two spatial streams

MCS	Data rates in Mbps - Nss=2					
	Channel width / Guard interval					
	20 MHz/ 800 ns	20 MHz/ 400 ns	40 MHz/ 800 ns	40 MHz/ 400 ns	80 MHz/ 800 ns	80 MHz/ 400 ns
0	13	14.4	27	30	58.5	65
1	26	28.9	54	60	117	130
2	39	43.3	81	90	175.5	195
3	52	57.8	108	120	234	260
4	78	86.7	162	180	351	390
5	104	115.6	216	240	468	520
6	117	130	243	270	526.5	585
7	130	144.4	270	300	585	650
8	156	173.3	324	360	702	780
9	n/a	n/a	360	400	780	866.7

Three spatial streams

MCS	Data rates in Mbps - Nss=3					
	Channel width / Guard interval					
	20 MHz/ 800 ns	20 MHz/ 400 ns	40 MHz/ 800 ns	40 MHz/ 400 ns	80 MHz/ 800 ns	80 MHz/ 400 ns
0	19.5	21.7	40.5	45	87.8	97.5
1	39	43.3	81	90	175.5	195

MCS	Data rates in Mbps - Nss=3					
	Channel width / Guard interval					
	20 MHz/ 800 ns	20 MHz/ 400 ns	40 MHz/ 800 ns	40 MHz/ 400 ns	80 MHz/ 800 ns	80 MHz/ 400 ns
2	58.5	65	121.5	135	263.3	292.5
3	78	86.7	162	180	351	390
4	117	130	243	270	526.5	585
5	156	173.3	324	360	702	780
6	175.5	195	364.5	405	n/a	n/a
7	195	216.7	405	450	877.5	975
8	234	260	496	540	1053	1170
9	260	288.9	540	600	1170	1300

- MHz = megahertz
- ns = nanoseconds
- VHT MCS 0 to MCS 9 are supported by the HP 517.
- On the HP 517, the guard interval is not configurable. It is always set to 400 ns, but will downgrade to 800 ns based on the capability of connected clients or the wireless environment.

Wireless access points

To view wireless information for an AP, select **Controlled APs** >> [group] > [AP] >> **Status** > **Wireless**.

The information you see will vary depending on the AP. For example, this is the status page for an HP 317:

Wireless status		Radio 1		
● Wireless Port is Up				
Frequency:	Channel 1, 2.412GHz		Tx packets:	0
Wireless mode:	802.11n/b/g (2.4 GHz)		Rx packets:	0
Operating mode:	AP only		Tx dropped:	0
Tx power:	15 dBm (EIRP)		Rx dropped:	0
Transmit protection status:	AG APs		Tx errors:	0
Tx multicast octets:	15929	Rx multicast octets:	16565	
Tx unicast octets:	187790	Rx unicast octets:	57043	
Tx broadcast octets:	9154	Rx broadcast octets:	8932	
Tx fragments:	2998	Rx fragments:	2998	
Tx multicast frames:	106	Rx multicast frames:	99	
Tx unicast frames:	382	Rx unicast frames:	381	
Tx broadcast frames:	67	Rx broadcast frames:	60	
Tx discards wrong SA:	0	Rx discards no buffer:	0	
Tx discards:	0	Rx discards WEP excluded:	0	
Tx retry limit exceeded:	0	Rx discards WEP ICV error:	0	
Tx multiple retry frames:	1106	Rx msg in bad msg fragments:	0	
Tx single retry frames:	2884	Rx msg in msg fragments:	550602	
Tx deferred transmissions:	0	Rx WEP undecryptable:	0	
QoS low priority tx:	0	Rx FCS errors:	36987	
QoS medium priority tx:	485			
QoS high priority tx:	0			
QoS very high priority tx:	3			
Clear Counters				

Wireless status

Wireless port

- **Up:** Port is operating normally.
- **Down:** Port is not operating.

Frequency

The current operating frequency.

Wireless mode

Current wireless mode.

Operating mode

Current operating mode.

Tx power

Current transmission power.

Transmit protection status

- **Disabled:** HT protection / G protection is disabled.
- **B clients:** G protection is enabled because a B client is connected to the AP.
- **B APs:** G protection is enabled because a B client is connected to another AP on the same channel used by the AP.
- **AG clients:** HT protection is enabled because a non-HT client is connected to the AP.
- **AG APs:** HT protection is enabled because a non-HT AP is present on the same channel used by the AP.

Tx multicast octets

The number of octets transmitted successfully as part of successfully transmitted multicast MSDUs. These octets include MAC Header and Frame Body of all associated fragments.

Tx unicast octets

The number of octets transmitted successfully as part of successfully transmitted unicast MSDUs. These octets include MAC Header and Frame Body of all associated fragments.

Tx fragments

The number of MPDUs of type Data or Management delivered successfully; i.e., directed MPDUs transmitted and being ACKed, as well as non-directed MPDUs transmitted.

Tx multicast frames

The number of MSDUs, of which the Destination Address is a multicast MAC address (including broadcast MAC address), transmitted successfully.

Tx unicast frames

The number of MSDUs, of which the Destination Address is a unicast MAC address, transmitted successfully. This implies having received an acknowledgment to all associated MPDUs.

Tx discards wrong SA

The number of transmit requests that were discarded because the source address is not equal to the MAC address.

Tx discards

The number of transmit requests that were discarded to free up buffer space on the AP. This can be caused by packets being queued too long in one of the transmit queues, or because too many retries and defers occurred, or otherwise not being able to transmit (for example, when scanning).

Tx retry limit exceeded

The number of times an MSDU is not transmitted successfully because the retry limit is reached, due to no acknowledgment or no CTS received.

Tx multiple retry frames

The number of MSDUs successfully transmitted after more than one retransmission (on the total of all associated fragments). May be due to collisions, noise, or interference. Excessive retries can indicate that too many computers are using the wireless network or that something is interfering with transmissions.

Tx single retry frames

The number of MSDUs successfully transmitted after one (and only one) retransmission (on the total of all associated fragments). May be due to collisions, noise, or interference. Large numbers of single retries can indicate that too many computers are using the wireless network or that something is interfering with transmissions.

Tx deferred transmissions

The number of MSDUs for which (one of) the (fragment) transmission attempt(s) was one or more times deferred to avoid a collision. Large numbers of deferred transmissions can indicate that too many computers are using the wireless network.

QoS low priority tx

Total number of QoS low priority packets that have been sent.

QoS medium priority tx

Total number of QoS medium priority packets that have been sent.

QoS high priority tx

Total number of QoS high priority packets that have been sent.

QoS very high priority tx

Total number of QoS very high priority packets that have been sent.

Tx packets

Not shown on the MSM410, HP 425, MSM430, MSM460, MSM466, and MSM466-R.
The total number of packets transmitted.

Tx dropped

Not shown on the MSM410, HP 425, MSM430, MSM460, MSM466, and MSM466-R.

The number of packets that could not be transmitted. This can occur when the wireless configuration is being changed.

Tx errors

Not shown on the MSM410, HP 425, MSM430, MSM460, MSM466, and MSM466-R.

The total number of packets that could not be sent due to the following errors: Rx retry limit exceeded and TX discards wrong SA.

Rx packets

Not shown on the MSM410, HP 425, MSM430, MSM460, MSM466, and MSM466-R.

The total number of packets received.

Rx dropped

Not shown on the MSM410, HP 425, MSM430, MSM460, MSM466, and MSM466-R.

The number of received packets that were dropped due to lack of resources on the AP. This should not occur under normal circumstances. A possible cause could be if many client stations are continuously transmitting small packets at a high data rate.

Rx multicast octets

The number of octets received successfully as part of multicast (including broadcast) MSDUs. These octets include MAC Header and Frame Body of all associated fragments.

Rx unicast octets

The number of octets received successfully as part of unicast MSDUs. These octets include MAC Header and Frame Body of all associated fragments.

Rx fragments

The number of MPDUs of type Data or Management received successfully.

Rx multicast frames

The number of MSDUs, with a multicast MAC address (including the broadcast MAC address), as the Destination Address, received successfully.

Rx unicast frames

The number of MSDUs, with a unicast MAC address as the Destination Address received successfully.

Rx discards no buffer

The number of received MPDUs that were discarded because of lack of buffer space.

Rx discards WEP excluded

The number of discarded packets, excluding WEP-related errors.

Rx discards WEP ICV error

The number of received MPDUs that were discarded due to malformed WEP packets.

Rx MSG in bad msg fragments

The number of MPDUs of type Data or Management received successfully, while there was another reception going on above the carrier detect threshold but with bad or incomplete PLCP Preamble and Header (the message-in-message path #2 in the modem).

Rx MSG in msg fragments

The number of MPDUs of type Data or Management received successfully, while there was another good reception going on above the carrier detect threshold (the message-in-message path #2 in the modem).

Rx WEP undecryptable

The number of received MPDUs, with the WEP subfield in the Frame Control field set to one, that were discarded because it should not have been encrypted or due to the receiving station not implementing the privacy option.

Rx FCS errors

The number of MPDUs, considered to be destined for this station (Address matches), received with an FCS error. Note that this does not include data received with an incorrect CRC in the PLCP header. These are not considered to be MPDUs.

Clear counters

Select this button to reset all counters to zero.

7 Working with VSCs

Key concepts

A VSC (virtual service community) is a collection of configuration settings that define key operating characteristics of the controller and controlled APs. In most cases, a VSC is used to define the characteristics of a wireless network and to control how wireless user traffic is distributed onto the wired network.

Multiple VSCs can be active at the same time, allowing for great flexibility in the configuration of services. Up to 64 VSC profiles can be configured, provided proper licensing is used.

In the following scenario, four VSCs are used to support different types of wireless users. Each VSC is configured with a different wireless network name (SSID), and the quality of service (QoS) feature is used to classify user traffic priority.

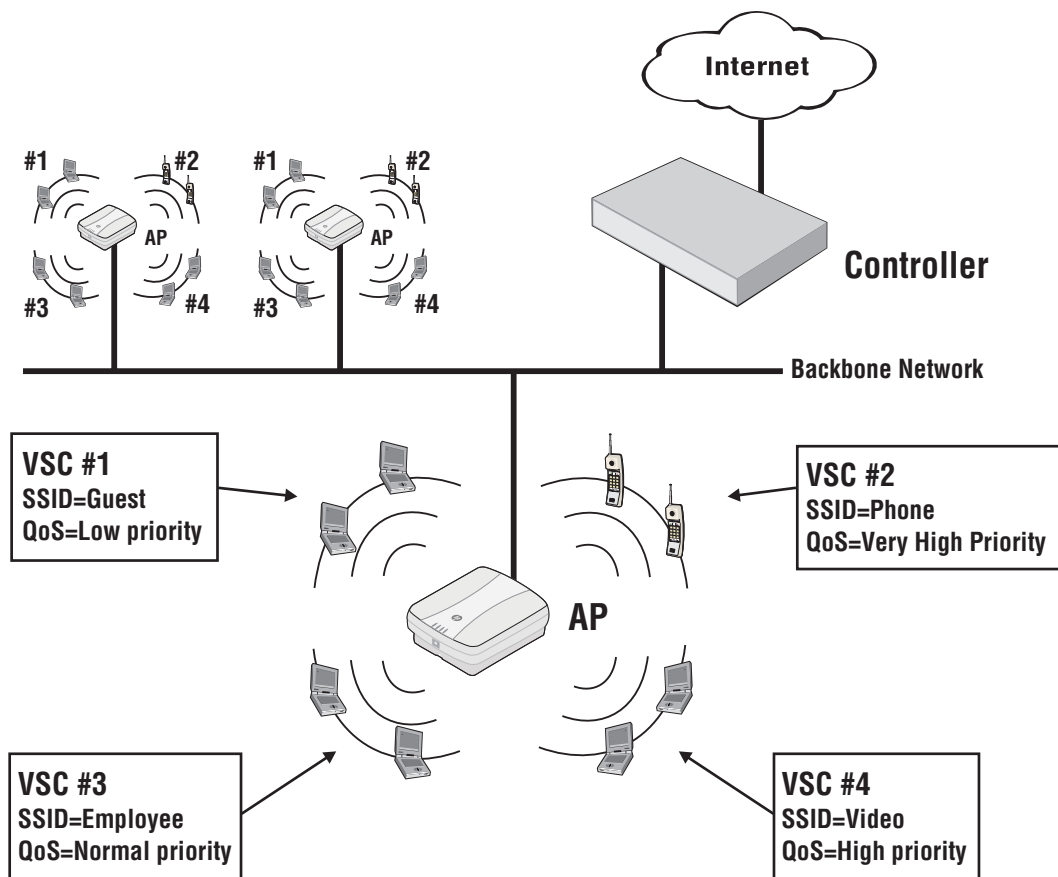

Binding VSCs to APs

VSCs are defined on the controller, creating a global pool of services. From this pool, specific VSCs are then *bound* to one or more groups (and the APs in the groups), to provide a homogeneous wireless offering. See “[Binding VSCs to groups](#)” (page 163).

NOTE: The MSM760, MSM765 zl, and MSM775 zl controllers support up to 64 VSCs. The MSM720 supports 16 VSCs by default, and 64 VSCs when the Premium Mobility License is installed. Controlled APs support a maximum of 16 VSCs.

Viewing and editing VSC profiles

The VSC profiles list shows all VSCs that are currently defined on the controller. To open the list, select **VSCs** in the **Network Tree**.

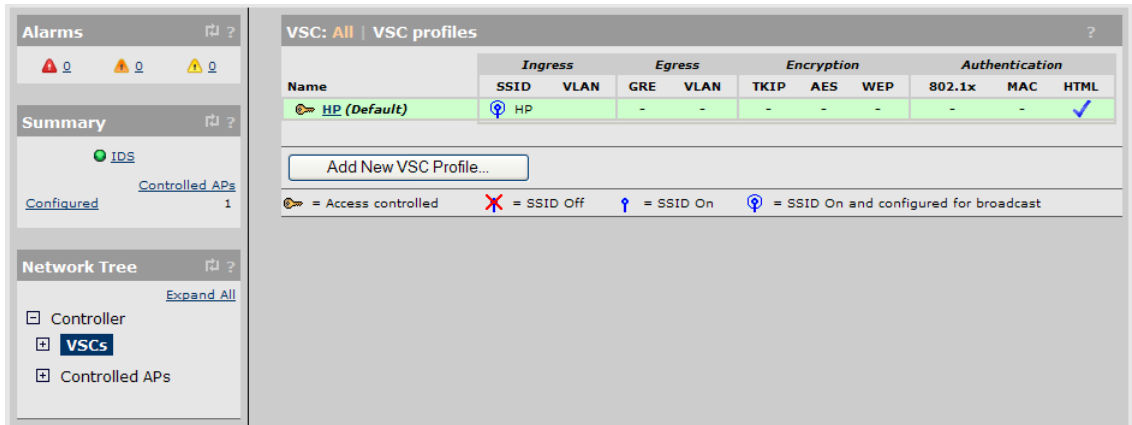

The **HP** VSC profile is defined by default.

- To add a VSC, select **VSCs >> Overview > VSC profiles > Add New VSC Profile**.
- To edit a VSC, select its name in the VSC list, or in the **Network Tree**.

In either case, the VSC profile page opens. In this page sample, only the top of the VSC profile page is shown.

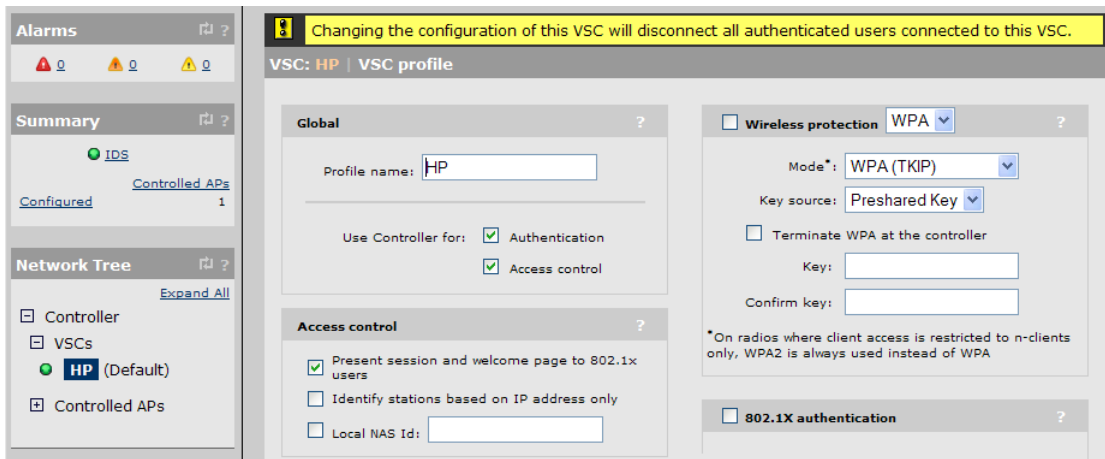

The default VSC

The default VSC is used as a fallback for any traffic that goes through the controller and that cannot be identified as coming from an MSM AP. It is also used to handle all non-VLAN traffic from wired devices connected to the controller LAN port (i.e., traffic from 3rd-party APs or wired users on the network). See [“About the default VSC” \(page 139\)](#).

VSC configuration options

This section provides an overview of all the configuration options available for a VSC. It will give you a good idea on how the features can be used.

The default VSC is pre-configured as described in the following pages. Below, is an overview of the entire VSC configuration page.

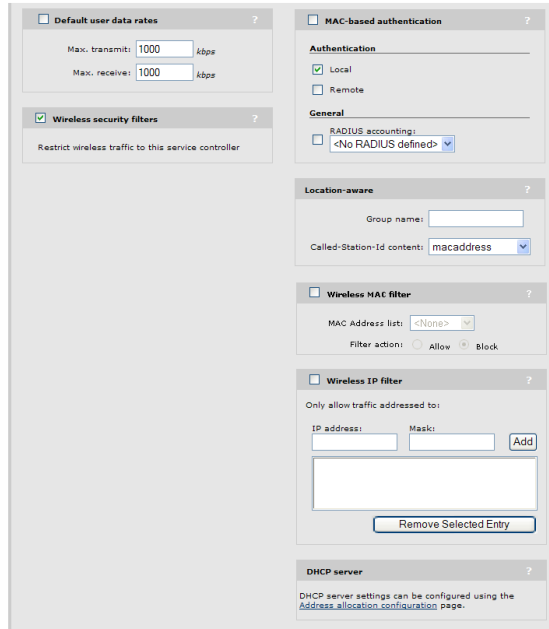
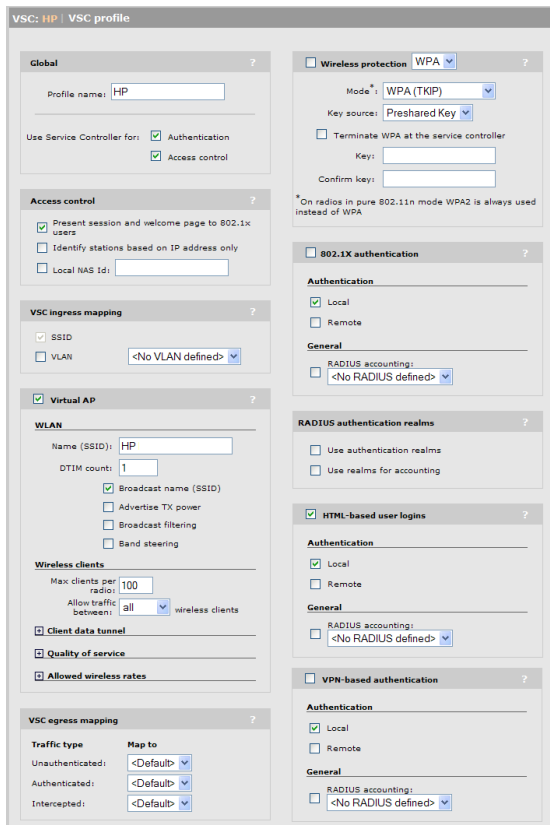

About access control and authentication

The availability of certain VSC features and their functionality is controlled by the settings of two important parameters in the **Global** box. These parameters determine how authentication and access control are handled by the VSC:

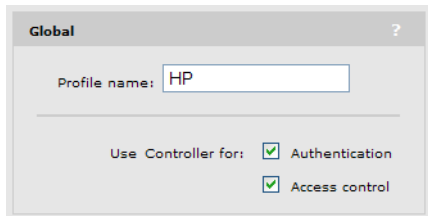

Use Controller for: Authentication

Determines if user authentication services (802.1X, WPA, WPA2, HTML-based, MAC-based) are provided by the controller. When enabled, APs forward user login requests to the controller. The controller resolves these requests using the local user accounts, or Active Directory, or acts as a RADIUS proxy for a third-party RADIUS server.

Use Controller for: Access control

This option can only be enabled if the **Authentication** option is enabled first. When enabled, this option creates an *access-controlled* VSC. This means that access to protected network resources via this VSC are restricted by the access control features on the controller. Access control features include the public/guest network access interface and access lists.

The following diagrams provide an overview of how user authentication and data traffic are handled depending on how these options are configured.

When both authentication and access control are enabled

In this configuration, the controlled AP forwards authentication requests from users on the VSC to the controller. The controller resolves these requests using the local user list, or the services of a third-party authentication server (Active Directory or RADIUS server). The controller then manages access to the protected network using its access control features (public access, interface, access lists, etc.).

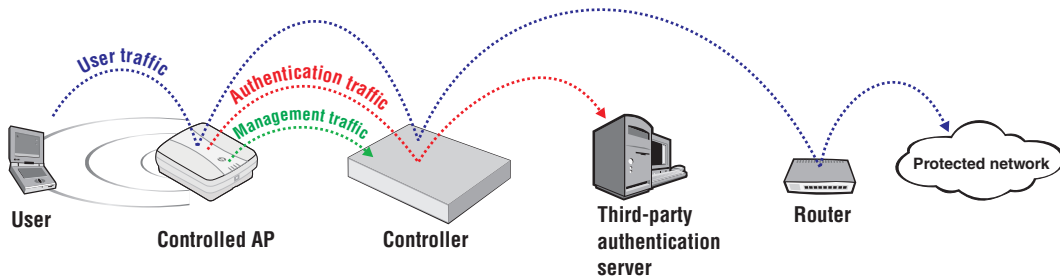

When only authentication is enabled

In this configuration, the controlled AP forwards authentication requests from users on the VSC to the controller. The controller resolves these requests using the local user list, or the services of a third-party authentication server (Active Directory or RADIUS server).

The controlled AP forwards all authenticated user traffic from users on the VSC to the protected network (or another device performing access control) according to settings defined on the controlled AP.

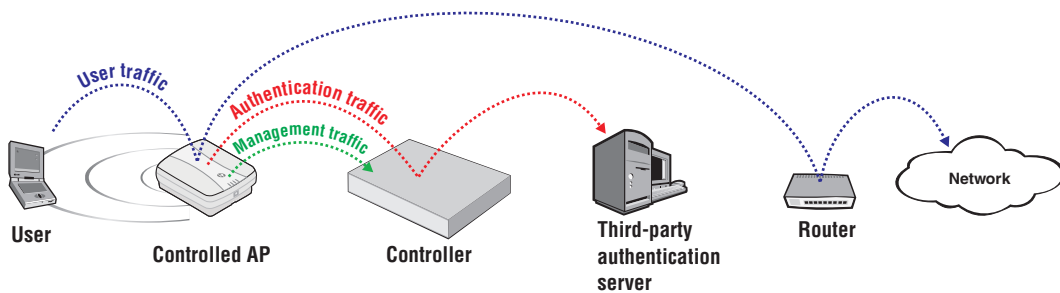

When neither option is enabled

In this configuration, the controlled AP can be configured to resolve authentication requests using a third-party RADIUS server and forward authenticated user traffic to the protected network (or another device performing access control). In this scenario, the controller is only used for management of the controlled AP.

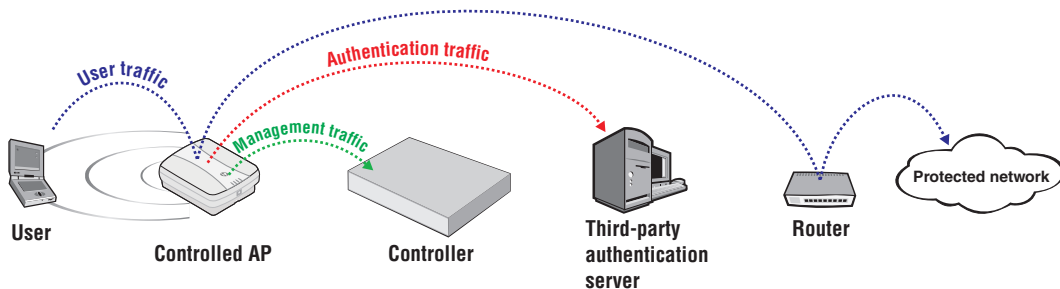

Summary of VSC configuration options

The following table lists the VSC configuration options that are available depending on how access control and authentication are configured.

VSC configuration option	Use Controller for:		
	Authentication and Access control	Authentication only	Neither
Access control	✓	×	×
Virtual AP	✓	✓	✓
VSC ingress mapping	✓	✓	×
VSC egress mapping	✓	×	×
Default user data rates	✓	×	×
Wireless mobility	×	✓	✓
Fast wireless roaming	×	✓	✓
Wireless security filters	✓	✓	✓
Wireless protection	✓	✓	✓
802.1X authentication	✓	✓	✓
RADIUS authentication realms	✓	✓	×
HTML-based user logins	✓	×	×
VPN-based authentication	✓	×	×
MAC-based authentication	✓	✓	✓
Location-aware	✓	×	×
Wireless MAC filter	✓	✓	✓
Wireless IP filter	✓	✓	✓
DHCP server	✓	×	×
DHCP relay	✓	×	×

The sections that follow provide an overview and use of each VSC option. For complete descriptions of individual parameters see the online help in the management tool.

Access control

These settings only apply to access-controlled VSCs.

The screenshot shows a configuration window titled "Access control" with a question mark icon. It contains three settings:

- Present session and welcome page to 802.1x users
- Identify stations based on IP address only
- Local NAS Id:

Present session and welcome page to 802.1X users

Enable this option to have the public access interface present the Welcome, Transport, and Session pages to 802.1X users.

When disabled, these pages are not sent to 802.1X users.

NOTE: Display of the Session page (and other pages that are part of the public access interface) may not work for all users. These pages will fail if the initial traffic from the users computer is sent by an application other than the users browser. For example: messaging software, automatic software update services, e-mail applications.

Identify stations based on IP address only

This option only applies when the **HTML-based user logins** option is enabled.

This option controls how client stations are identified once they are logged in.

- **When enabled**, the controller identifies client stations by their IP address only. This setting provides support for network configurations where the MAC address of wireless stations is not visible to the controller, or for configurations where the MAC address changes when a client station roams.
- **When disabled** (default setting), the controller identifies client stations by both IP address and MAC address. Both addresses must remain the same after login for the client station to remain authenticated.

Local NAS ID

Defines a NAS ID for this profile. This ID is used only when RADIUS authentication is not configured for the profile.

Virtual AP

The virtual AP settings define the characteristics of the wireless network created by the VSC, including its name, the number of clients supported, and QoS settings.

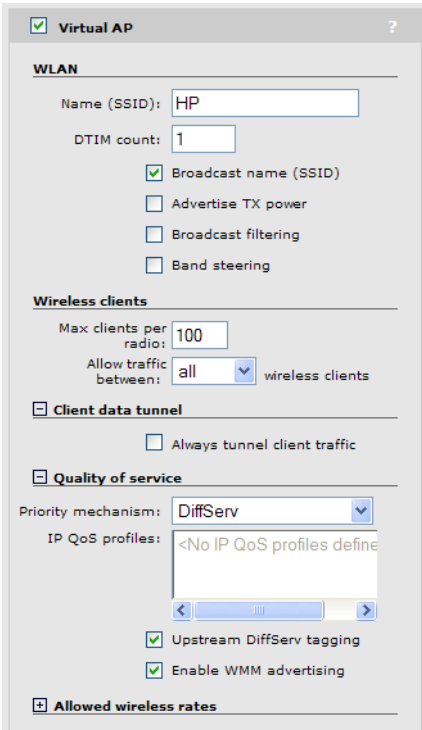
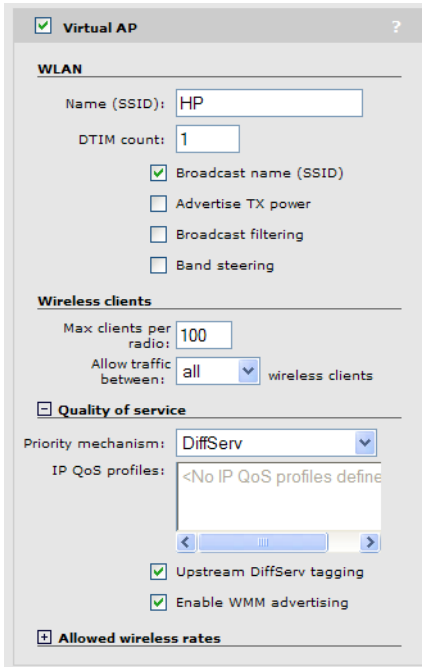
Access control enabled	Access control disabled
 <p>The screenshot shows the Virtual AP configuration page with the 'Virtual AP' checkbox checked. Under the 'WLAN' section, the Name (SSID) is 'HP' and DTIM count is '1'. The 'Broadcast name (SSID)' checkbox is checked, while 'Advertise TX power', 'Broadcast filtering', and 'Band steering' are unchecked. Under 'Wireless clients', 'Max clients per radio' is '100' and 'Allow traffic between' is set to 'all'. The 'Client data tunnel' section has 'Always tunnel client traffic' unchecked. The 'Quality of service' section has 'Priority mechanism' set to 'DiffServ' and 'IP QoS profiles' set to '<No IP QoS profiles define'. 'Upstream DiffServ tagging' and 'Enable WMM advertising' are checked. The 'Allowed wireless rates' section is collapsed.</p>	 <p>The screenshot shows the Virtual AP configuration page with the 'Virtual AP' checkbox checked. Under the 'WLAN' section, the Name (SSID) is 'HP' and DTIM count is '1'. The 'Broadcast name (SSID)' checkbox is checked, while 'Advertise TX power', 'Broadcast filtering', and 'Band steering' are unchecked. Under 'Wireless clients', 'Max clients per radio' is '100' and 'Allow traffic between' is set to 'all'. The 'Quality of service' section has 'Priority mechanism' set to 'DiffServ' and 'IP QoS profiles' set to '<No IP QoS profiles define'. 'Upstream DiffServ tagging' and 'Enable WMM advertising' are checked. The 'Allowed wireless rates' section is expanded.</p>

Select the **Virtual AP** checkbox to enable the wireless network defined by this VSC.

WLAN

Name (SSID):

DTIM count:

Broadcast name (SSID)

Advertise TX power

Broadcast filtering

Band steering

Settings

Name (SSID)

Specify a name to uniquely identify the wireless network associated with this VSC. The wireless network is created by the controlled APs and managed by the controller.

Each wireless user that wants to connect to this VSC must use the WLAN name. The name is case-sensitive.

DTIM count

Specify the DTIM period in the wireless beacon sent by the controlled APs. Client stations use the DTIM to wake up from low-power mode to receive multicast traffic.

APs transmit a beacon every 100 ms. The DTIM counts down with each beacon that is sent. Therefore if the DTIM is set to 5, then client stations in low-power mode will wake up every 500 ms (.5 second) to receive multicast traffic.

Broadcast name (SSID)

When this option is enabled, APs will broadcast the wireless network name (SSID) to all client stations. Most wireless adapter cards have a setting that enables them to automatically discover APs that broadcast their names and connect to the one with the strongest signal.

If you disable this option, client stations will have to specify the network name you enter for **Name (SSID)** when they connect.

Advertise Tx power

When this option is enabled, APs broadcast their current transmit power setting in the wireless beacon. It also enables support for 802.11h and 802.11d.

Broadcast filtering

Use this option to conserve wireless bandwidth by filtering out non-essential broadcast traffic. When broadcast filtering is enabled:

- DHCP broadcast requests are never forwarded on the wireless port.
- DHCP broadcast offers are never forwarded on the wireless port unless the target of the offer is an associated client on the wireless interface.
- ARP broadcast requests are never forwarded out the wireless port unless the target of the ARP request is an associated client on the wireless interface.

Broadcast filtering should be disabled in the following cases:

- An external DHCP server is connected to the wireless network.
- If a wireless client bridge is connected to the wireless network.

Band steering

Supported on: MSM422, HP 425, MSM430, MSM460, MSM466, MSM466-R

Band steering is used to help solve dense client issues. When band steering is enabled, APs attempt to move wireless clients that are capable of 802.11 a/n onto the 5 GHz band, thus reducing the load on the slower and more crowded 2.4 GHz band, leaving it for less capable legacy (802.11 b/g) clients.

An AP uses the following methods to encourage a wireless client to associate at 5 GHz instead of 2.4 GHz.

- The AP waits 200 ms before responding to the first probe request sent by a client at 2.4 GHz.
- If the AP has learned that a client is capable of transmitting at 5 GHz, the AP refuses the first association request sent by the client at 2.4 GHz.
- Once a client is associated at 5 GHz, the AP will not respond to any 2.4 GHz probes from the client as long as the clients signal strength at 5 GHz is greater than -80 dBm (decibel milliwatt). If the clients signal strength falls below -80 dBm, then the AP will respond to 2.4 GHz probes from the client without delay.

NOTE:

- To support band steering, the VSC must be bound to APs with two radios (MSM422, HP 425, MSM430, MSM460, MSM466, or MSM466-R). One radio must be configured for 2.4 GHz operation and the other for 5 GHz operation.
 - Band steering is temporarily suspended on an AP when the radio configured for 5 GHz operation reaches its maximum number of supported clients.
-

Wireless clients

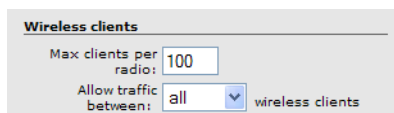

Wireless clients

Max clients per radio:

Allow traffic between: wireless clients

Settings

Max clients per radio

Specify the maximum number of wireless client stations that can be associated with this SSID at the same time on each radio.

Allow traffic between nn wireless clients

Use this option to control how non-access-controlled wireless clients that are connected to the same VSC can communicate with each other. The following settings are available:

- **no**: Blocks all inter-client communications.
- **802.1X**: Only authenticated 802.1X clients can communicate.
- **all**: All authenticated and unauthenticated clients can communicate. Default setting.
- **IPv6**: Only authenticated clients using IP version 6 can communicate.

Communications between client stations connected to different non-access-controlled VSCs can only occur if the clients are both assigned to the same VLAN. The easiest way to do this is to assign the same VLAN to both VSCs using the **Egress network** option when binding the VSC to an AP. A second option is to configure the same VLAN for the **VSC egress mapping** in each VSC. Another method, is to dynamically assign the same VLAN to two different users via RADIUS or the local user accounts. See [“User-assigned VLANs” \(page 221\)](#).

In addition, the following rules govern how traffic is exchanged:

- Unicast traffic exchanged between VSCs on the **same** radio is controlled by the setting of either the sender's or the receiver's VSC.
- Unicast traffic exchanged between VSCs on **different** radios is controlled by the setting of the sender's VSC.
- Multicast traffic exchanged between VSCs is always controlled by the setting of the senders VSC.

Generally, most clients will be involved in the bidirectional exchange of unicast packets. In this case, the rules can be simplified by assuming that the most restrictive setting for this option takes precedence. For example:

- If VSC1 is set to **No** and VSC2 is set to **All**, no communication is permitted between clients on the two VSCs, or between clients on VSC1. However, all clients on VSC2 can communicate with each other.
- If VSC1 is set to **802.1X** and VSC2 set to **All**, only 802.1X clients can communicate between the two VSCs.

Client data tunnel

(Only available when **Access control** is enabled.)

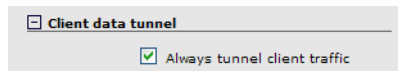

When a VSC is access-controlled, client traffic that is sent between the AP and controller can be carried in the client data tunnel. This provides the following benefits:

- User traffic is segregated from the backbone network and can only travel to the controller.
- Underlying network topology is abstracted enabling full support for L2-connected users across routed networks.

The client data tunnel is always used when the connection between a controlled AP and its controller traverses at least one router. The client data tunnel supports NAT traversal, so it can cross routers that implement NAT. It is also always used when teaming is enabled, or when a controlled AP is discovered via the Internet port (Internet network on the MSM720).

Optionally, the client data tunnel can be used when a controlled AP and its controller are on the same subnet. To do this, enable the **Always tunnel client traffic** option.

Performance and security settings for the client data tunnel can be customized by selecting **Controller >> Controlled APs > Client data tunnel**.



- **Less security/better performance:** This option provides security using a secret key that is attached to each packet. The key is rotated every 200 seconds.
- **High security/less performance:** This option uses HMAC (Hash based message authentication code) to ensure the data integrity and authenticity of each packet. Performance is reduced due to the overhead needed to calculate HMAC.

Regardless of the security method used, the client tunnel **does not encrypt the data stream**. To protect client traffic with encryption requires that client stations use WPA or VPN software.

- Under **Wireless protection**, enable **WPA** with the **Terminate WPA at the controller**. This requires client stations that support WPA.
- Use **VPN-based authentication**. See [“Securing wireless client sessions with VPNs” \(page 507\)](#).

Quality of service

The quality of service (QoS) feature provides a number of different mechanisms to prioritize wireless traffic sent to wireless client stations. See “Quality of service” (page 139).

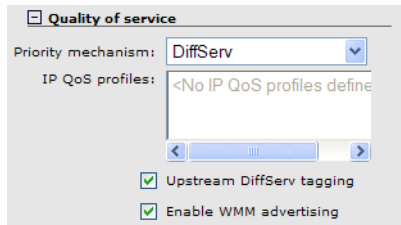

Allowed wireless rates

Select the wireless transmission speeds (in Mbps) that this VSC will support for each wireless mode. Clients will only be able to connect at the rates that you select. If a client does not support the selected rate and mode, it will not be able to connect to this VSC.

Allowed wireless rates

802.11b	802.11g	802.11b+g	802.11a	802.11n	802.11ac
<input checked="" type="checkbox"/> 1	<input checked="" type="checkbox"/> 6	<input checked="" type="checkbox"/> 1	<input checked="" type="checkbox"/> 6	<input checked="" type="checkbox"/> 1	<input checked="" type="checkbox"/> 6
<input checked="" type="checkbox"/> 2	<input checked="" type="checkbox"/> 9	<input checked="" type="checkbox"/> 2	<input checked="" type="checkbox"/> 9	<input checked="" type="checkbox"/> 2	<input checked="" type="checkbox"/> 9
<input checked="" type="checkbox"/> 5.5	<input checked="" type="checkbox"/> 12	<input checked="" type="checkbox"/> 5.5	<input checked="" type="checkbox"/> 12	<input checked="" type="checkbox"/> 5.5	<input checked="" type="checkbox"/> 12
<input checked="" type="checkbox"/> 11	<input checked="" type="checkbox"/> 18	<input checked="" type="checkbox"/> 6	<input checked="" type="checkbox"/> 18	<input checked="" type="checkbox"/> 6	<input checked="" type="checkbox"/> 18
	<input checked="" type="checkbox"/> 24	<input checked="" type="checkbox"/> 9	<input checked="" type="checkbox"/> 24	<input checked="" type="checkbox"/> 9	<input checked="" type="checkbox"/> 24
	<input checked="" type="checkbox"/> 36	<input checked="" type="checkbox"/> 11	<input checked="" type="checkbox"/> 36	<input checked="" type="checkbox"/> 11	<input checked="" type="checkbox"/> 36
	<input checked="" type="checkbox"/> 48	<input checked="" type="checkbox"/> 12	<input checked="" type="checkbox"/> 48	<input checked="" type="checkbox"/> 12	<input checked="" type="checkbox"/> 48
	<input checked="" type="checkbox"/> 54	<input checked="" type="checkbox"/> 18	<input checked="" type="checkbox"/> 54	<input checked="" type="checkbox"/> 18	<input checked="" type="checkbox"/> 54
		<input checked="" type="checkbox"/> 24		<input checked="" type="checkbox"/> 24	<input checked="" type="checkbox"/> MCS 0
		<input checked="" type="checkbox"/> 36		<input checked="" type="checkbox"/> 36	<input checked="" type="checkbox"/> MCS 1
		<input checked="" type="checkbox"/> 48		<input checked="" type="checkbox"/> 48	<input checked="" type="checkbox"/> MCS 2
		<input checked="" type="checkbox"/> 54		<input checked="" type="checkbox"/> 54	<input checked="" type="checkbox"/> MCS 3
				<input checked="" type="checkbox"/> MCS 0	<input checked="" type="checkbox"/> MCS 4
				<input checked="" type="checkbox"/> MCS 1	<input checked="" type="checkbox"/> MCS 5
				<input checked="" type="checkbox"/> MCS 2	<input checked="" type="checkbox"/> MCS 6
				<input checked="" type="checkbox"/> MCS 3	<input checked="" type="checkbox"/> MCS 7
				<input checked="" type="checkbox"/> MCS 4	<input checked="" type="checkbox"/> MCS 8
				<input checked="" type="checkbox"/> MCS 5	<input checked="" type="checkbox"/> MCS 9
				<input checked="" type="checkbox"/> MCS 6	<input checked="" type="checkbox"/> MCS 10
				<input checked="" type="checkbox"/> MCS 7	<input checked="" type="checkbox"/> MCS 11
				<input checked="" type="checkbox"/> MCS 8	<input checked="" type="checkbox"/> MCS 12
				<input checked="" type="checkbox"/> MCS 9	<input checked="" type="checkbox"/> MCS 13
				<input checked="" type="checkbox"/> MCS 10	<input checked="" type="checkbox"/> MCS 14
				<input checked="" type="checkbox"/> MCS 11	<input checked="" type="checkbox"/> MCS 15
				<input checked="" type="checkbox"/> MCS 12	<input checked="" type="checkbox"/> MCS 16
				<input checked="" type="checkbox"/> MCS 13	<input checked="" type="checkbox"/> MCS 17
				<input checked="" type="checkbox"/> MCS 14	<input checked="" type="checkbox"/> MCS 18
				<input checked="" type="checkbox"/> MCS 15	<input checked="" type="checkbox"/> MCS 19
				<input checked="" type="checkbox"/> MCS 16	<input checked="" type="checkbox"/> MCS 20
				<input checked="" type="checkbox"/> MCS 17	<input checked="" type="checkbox"/> MCS 21
				<input checked="" type="checkbox"/> MCS 18	<input checked="" type="checkbox"/> MCS 22
				<input checked="" type="checkbox"/> MCS 19	<input checked="" type="checkbox"/> MCS 23
				<input checked="" type="checkbox"/> MCS 20	Nss=1 VHT MCS 0-9
				<input checked="" type="checkbox"/> MCS 21	Nss=2 VHT MCS 0-9
				<input checked="" type="checkbox"/> MCS 22	Nss=3 VHT MCS 0-9
				<input checked="" type="checkbox"/> MCS 23	

All APs do not support all wireless modes and rates.

- **MCS 0 to MCS 15** are supported by the MSM410, MSM422, HP 425, MSM430, MSM460, MSM466, MSM466-R, and HP 517.
- **MCS 16 to MCS 23** are supported by the MSM460, MSM466, MSM466-R, and HP 517.
- **VHT MCS 0 to MCS 9** are supported by the HP 517.

To ensure a high quality of service for voice applications, disable all rates below 5.5. Also, ensure that the radio is configured as follows:

- **Operating mode** is set to **Access point only**.
- **Channel** is set to a fixed channel, or **Automatic** with **interval** set to **Disabled**.
- **Automatic power control** is disabled under **Transmit power control**.

Notes on 802.11ac/n

- 802.11n supports legacy rates (1 to 54), as well as high-throughput (HT) rates MCS 0 to MCS 23.
- You must always enable at least one legacy rate for 802.11n.
- 802.11ac supports legacy rates (6 to 54), as well as high-throughput (HT) rates MCS 0 to MCS 23, and very high-throughput (VHT) rates MCS 0 to MCS 9. The supported VHT rates are configurable depending on the number of spacial streams (Nss): 1, 2, or 3.
- VHT MCS 9 is not supported for Nss=1 or 2 when using the 20 MHz channel width.
- VHT MCS 6 is not supported for Nss=3 when using the 80 MHz channel width.

Note regarding the HP 425, MSM430, MSM460, MSM466, and MSM466-R

On these products, the wireless rates shown for 802.11n apply to all wireless modes supported on both radios, which are 802.11/a/b/g/n. If you remove a rate, it is removed for all wireless modes.

VSC ingress mapping

These settings apply to the controller only and define how ingress (incoming) user traffic is assigned to a VSC on the controller. The ingress lets you control what type of traffic the VSC will handle.

Untagged traffic on the LAN port (LAN Network on the MSM720), that is from wired client stations or third-party APs is always handled by the default VSC defined on the controller.

- When access control is enabled, available options are:

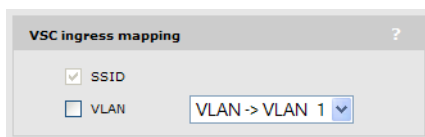

The **SSID** option cannot be disabled. When enabled, the VSC accepts incoming traffic that has its SSID set to the **WLAN name (SSID)** defined under **Virtual AP**.

If you enable the **VLAN** option, you can choose a network profile that is mapped to a single VLAN, or a VLAN range, enabling the VSC to handle traffic from multiple sources. For example, if you define different egress networks when binding VSCs to your APs, you could specify a range to have all traffic handled by one VSC. (Ingress VLANs are not supported when controller teaming is active.) For a network profile to appear in this list it must have a VLAN assigned to it (on the **Controller >> Network > Network profiles** page) and be mapped to a port (on the **Controller >> Network > VLANs** page). However, it must not be assigned an IP address (on the **Controller >> Network > IP interfaces** page)

- When access control is disabled, available options are:



When the **SSID** option is enabled, the VSC accepts incoming traffic that has its SSID set to the **WLAN name (SSID)** defined under **Virtual AP**.

The **Ethernet Switch** option enables the VSC to be bound to the switch ports on an HP 517 or MSM317. See the *HP 517 802.11ac Unified Walljack Configuration Guide* and the *MSM317 Access Device Installation and Configuration Guide*.

If a VSC is bound to an HP 517 or MSM317 switch port, it cannot handle traffic from wireless clients on the HP 517/MSM317 or any other APs. The switch port must be bound to this VSC by selecting **Controlled APs >> Configuration > Switch ports > [HP 517 or MSM317] > [switch_port_name]**.

For more information, see [“VSC data flow”](#) (page 135) and [“Traffic flow for wireless users”](#) (page 221).

VSC egress mapping

These options select the output interface on the controller on which an access-controlled VSC forwards user traffic. Different egress mappings can be defined depending on whether the user is unauthenticated, authenticated, or being intercepted. (To enable traffic interception for a specific user, you must specify the appropriate setting in the users RADIUS account. See [Colubris-Intercept](#).)

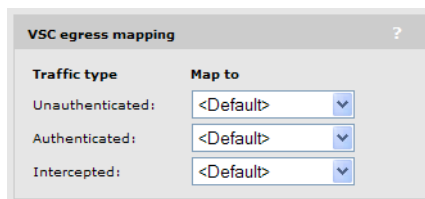

Traffic type	Map to
Unauthenticated:	<Default>
Authenticated:	<Default>
Intercepted:	<Default>

Before you can map traffic to an output interface, the interface must already be defined. For a network profile to appear in this list, it must:

- Have a VLAN assigned to it (on the **Controller >> Network > Network profiles** page)
- Be mapped to a port (on the **Controller >> Network > VLANs** page)
- Be assigned an IP address (on the **Controller >> Network > IP interfaces** page)

When the **Default** option is selected, the controller routing table is used for all egress traffic. Therefore, all traffic on this VSC is routed according to the routes defined on the **Controller >> Network > IP routes** page.

For more information, see [“VSC data flow”](#) (page 135) and [“Traffic flow for wireless users”](#) (page 221).

NOTE: To set VSC egress options for controlled APs, see [“Binding VSCs to groups”](#) (page 163). On the HP 517 or MSM317, VSCs can also be bound directly to the switch ports. See the *HP 517 802.11ac Unified Walljack Configuration Guide* and the *MSM317 Access Device Installation and Configuration Guide*.

Bandwidth control

This option is only available if the **Data rate limits option** is enabled on the **Controller >> Network > Bandwidth control** page. See [“Bandwidth control”](#) (page 51).

Select the bandwidth level to regulate traffic flow for all user traffic handled by this VSC. Bandwidth levels are defined on the **Controller >> Network > Bandwidth control** page.

This default setting applies to all users that do not have a bandwidth level assigned in their account (local or RADIUS). Local accounts are defined on the Users menu.

For more information on setting the appropriate RADIUS attributes to accomplish this, see [“Public/guest network access”](#) (page 396) and [“Working with RADIUS attributes”](#) (page 435).

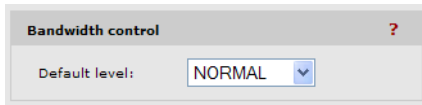

Default user data rates

These options enable you to set the default data rates for authenticated users that do not have a data rate set in their RADIUS accounts, and for unauthenticated users. For details on setting user data rates using RADIUS attributes, see [“Public/guest network access” \(page 396\)](#) and [“Working with RADIUS attributes” \(page 435\)](#).

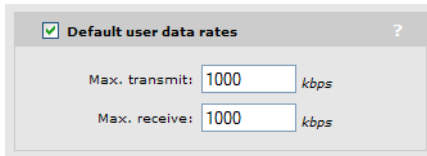

Settings

Max transmit

Specify the maximum rate (in kbps) at which users can send data.

Max receive

Specify the maximum rate (in kbps) at which users can receive data.

NOTE: The **Data rate limits** defined on the **Controller >> Network > Bandwidth control** page always take precedence over user data rates set in the VSC. This means if you set a data rate which exceeds the configured bandwidth for the port, the rate will be capped.

Wireless mobility

The wireless mobility feature provides for seamless roaming of wireless users, while at the same time giving you complete control over how wireless user traffic is distributed onto the wired networking infrastructure. This enables you to implement a wireless networking solution that is perfectly tailored to meet the needs of your users and the topology of your network.

For detailed information on how to use and configure this feature, see [“Mobility traffic manager” \(page 285\)](#).

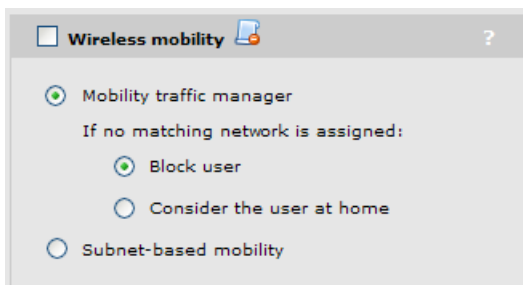

To use wireless mobility, you must:

- Disable the **Access control** option under **Global**.
- Install a **Mobility** or **Premium** license on the controller.

- Bind the same VSC to all APs that will support roaming.
- Configure the **Wireless security filters** so that they do not interfere with roaming functionality. In most cases, these filters should be disabled. If you need to use them, note that:
 - The **Restrict wireless traffic to: Access point default gateway** option is not supported.
 - The **Restrict wireless traffic to: MAC** or **Custom** options can be used but only if configured to restrict traffic to destinations that are reachable from all subnets in the mobility domain.

Mobility traffic manager

Mobility Traffic Manager (MTM) enables you to take advantage of both distributed and centralized strategies when deploying a wireless networking solution. For a complete discussion of this feature and how to use it see [“Mobility traffic manager” \(page 285\)](#).

If you are using MTM to tunnel the traffic from wireless users to their home networks, set the following parameter to determine how MTM routes traffic if no home network is assigned to a user (via their RADIUS account or local user account), or if the users home network is not found in the mobility domain.

If no matching network is assigned:

- **Block user:** User access is blocked.
- **Consider the user at home:** The users home network is considered to be the subnet assigned to the AP.

Subnet-based mobility

This feature has been deprecated. *If you are creating a new installation, use Mobility Traffic Manager. If you are upgrading from a previous release, your subnet-based configuration will still work. However, for added benefits and greater flexibility you should migrate your setup to Mobility Traffic Manager.*

When Subnet-based mobility is enabled, a users home subnet is determined based on the IPv4 address assigned to a user when they connect to the wireless network. If a users IPv4 address is not within the scope of any of the local subnets assigned to the AP, the user is considered foreign to the network and their traffic is tunnelled via the controller to their home subnet. If the users subnet does not match any subnets defined in the mobility domain, the user is blocked.

One issue with using this method to determine the home subnet is that a users IPv4 address is typically retrieved through DHCP. If a user connects to an AP in a new location (rather than roaming to the AP), the IP address assigned through DHCP may identify the user as local to the network, and not roaming.

Fast wireless roaming

WPA2 opportunistic key caching eliminates the delays associated with reauthentication when client stations roam between APs installed on the same subnet.

The controller manages key distribution between the APs so that when wireless users roam between APs, reauthentication is not delayed by having to completely renegotiate key values.

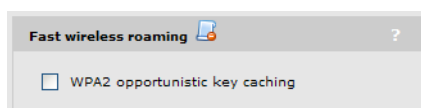

To support fast wireless roaming:

- Disable the **Access control** option under **Global**.
- Install a **Mobility** or **Premium** license on the controller.
- All APs must be on the same layer 2 network.

- All APs must have VSCs with the same name, SSID, and wireless protection settings.
- Wireless protection must be WPA, or 802.1X authentication must be enabled.

NOTE: RADIUS accounting is not supported when this option is enabled.

Wireless security filters

APs feature an intelligent bridge that can apply security filters to safeguard the flow of wireless traffic. These filters limit both incoming and outgoing traffic as defined below and force the APs to exchange traffic with a specific upstream device.

When access control is enabled, available options are:

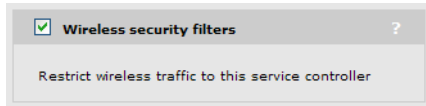

The controlled AP will only allow user traffic that is addressed to the controller. All other traffic is blocked. Make sure that the controller is set as the default gateway for all users. If not, all user traffic will be blocked by the AP.

The default wireless security filters defined below are active.

When access control is disabled, available options are:

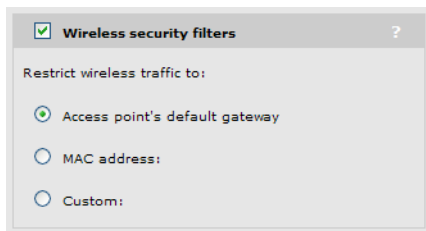

Configure security filter settings using the available options as described in the following section.

Settings

Restrict wireless traffic to

This setting defines the upstream device to which the AP will forward wireless traffic. If you are using multiple VLANs, each with a different gateway, use the **MAC address** option.

- **Access points default gateway:** This sends traffic to the default gateway assigned to the AP. The default wireless security filters are in effect for wireless traffic.
- **MAC address:** Specify the MAC address of the upstream device to which all traffic is to be forwarded. The default wireless security filters are in effect for wireless traffic.
- **Custom:** Use this option to define custom wireless security filters and a custom target address for the upstream device. Refer to the **Custom** section that follows for details.

Default wireless security filter definitions

The following filters are defined by default.

Incoming wireless traffic filters

Applies to traffic sent from wireless users to the AP.

Accepted

- Any IP traffic addressed to the controller.
- PPPoE traffic (The PPPoE server must be the upstream device.)

- IP broadcast packets, except NetBIOS
- Certain address management protocols (ARP, DHCP) regardless of their source address.
- Any traffic addressed to the AP, including 802.1X.

Blocked

- All traffic that is not accepted is blocked. This includes NetBIOS traffic regardless of its source/destination address. HTTPS traffic not addressed to the AP (or upstream device) is also blocked, which means wireless users cannot access the management tool on other HP APs.

Outgoing wireless traffic filters

Applies to traffic sent from the AP to wireless users.

Accepted

- Any IP traffic coming from the upstream device, except NetBIOS packets.
- PPPoE traffic from the upstream device.
- IP broadcast packets, except NetBIOS
- ARP and DHCP Offer and ACK packets.
- Any traffic coming from the AP itself, including 802.1X.

Blocked

- All other traffic is blocked. This includes NetBIOS traffic regardless of its source/destination address.

Custom wireless security filter definitions

Use this option to define your own security filters to control incoming and outgoing wireless traffic. To use the default filters as a starting point, select **Get Default Filters**.

Filters are specified using standard pcap syntax with the addition of a few HP-specific placeholders. These placeholders can be used to refer to specific MAC addresses and are expanded by the AP when the filter is activated. Once expanded, the filter must respect the pcap syntax. The pcap syntax is documented in the tcpdump man page:

http://www.tcpdump.org/tcpdump_man.html

Placeholders

- `%a` : MAC address of the controller.
- `%b` : MAC address of the bridge.
- `%g` : MAC address of the default gateway assigned to the AP.
- `%w` : MAC address of AP wireless port.

Wireless mobility considerations

If you enable the wireless mobility feature (to support roaming across different subnets), configuration of the wireless security filters must respect the following guidelines so as not to interfere with roaming functionality.

- The **Restrict wireless traffic to: Access point default gateway** option is not supported.
- The **Restrict wireless traffic to: MAC** or **Custom** options can be used provided that they restrict traffic to destinations that are reachable from all subnets in the mobile domain.

Wireless protection

Two types of wireless protection are offered. WPA and WEP.

WPA

This option enables support for users with WPA / WPA2 client software.

Mode

Support is provided for:

- **WPA (TKIP):** (Not supported on the HP 517.) WPA with TKIP encryption. When you enable this option, the VSC can only support legacy a/b/g traffic. All 802.11n features on a radio are disabled for this VSC..
- **WPA2 (AES/CCMP):** WPA2 (802.11i) with AES/CCMP encryption.
- **WPA or WPA2:** Mixed mode supports both WPA (version 1) and WPA2 (version 2) at the same time. Some legacy WPA clients may not work if this mode is selected. This mode is slightly less secure than using the pure WPA2 (AES/CCMP) option. **Note:** On radios that have **Client restriction** set to 802.11n only or 802.11ac only, WPA2 is always used instead of WPA.

Key source

This option determines how the TKIP keys are generated.

- **Dynamic:** This is a dynamic key that changes each time the user logs in and is authenticated. The MPPE key is used to generate the TKIP keys that encrypt the wireless data stream. The key is generated via the configured **802.1X authentication** method. Therefore, when you enable this option, the **802.1X authentication** feature is automatically enabled.

Authentication can occur via the local user accounts and a remote authentication server (Active Directory, or third-party RADIUS server). If both options are enabled, the local accounts are checked first.

Wireless protection WPA ?

Mode * : WPA (TKIP)

Key source: Dynamic

Terminate WPA at the controller

* On radios in pure 802.11n mode WPA2 is always used instead of WPA

802.1X authentication ?

Authentication

Local

Remote

General

RADIUS accounting: <No RADIUS defined>

- **Preshared Key:** The controller uses the key you specify in the **Key** field to generate the TKIP keys that encrypt the wireless data stream. Since this is a static key, it is not as secure as the RADIUS option. Specify a key that is between 8 and 63 alphanumeric characters in length. HP recommends that the preshared key be at least 20 characters long, and be a mix of letters and numbers. The double quote character (") should not be used.

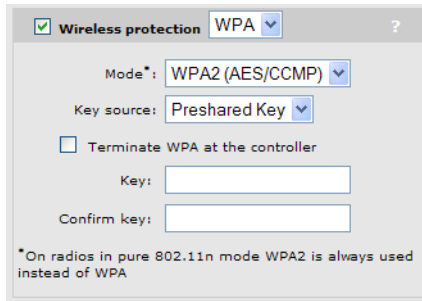

Terminate WPA at the controller

This feature is intended for low throughput applications, such as supporting point of sale (POS) terminals.

Enabled

When enabled, the controller acts as the termination point for all WPA/WPA2 sessions. This enables the network to meet PCI (Payment Card Industry) compliance supporting the connection of point of sale (POS) terminals.

Disabled

When disabled, WPA/WPA2 sessions are terminated at the AP. This means that wireless communication between the client station and AP is secure, but traffic between the AP and controller is not. This is normally sufficient since outsiders do not have access to your wired network. However, in a public venue such as a hotel, if the public has access to your wired network, it may be necessary to provide end-to-end security for certain client stations, such as POS terminals.

NOTE:

- This feature supports a maximum of 10 sessions on the MSM720 and 50 sessions on the MSM760, MSM765 zl, and MSM775 zl.
 - A VSC that is configured with the option **Terminate WPA at the controller** cannot be bound to an HP 517 or an AP group that contains an HP 517.
-

WEP

This option provides support for users using WEP encryption.

NOTE: When the radio used by a VSC is configured to support 802.11n or 802.11ac, and the VSC is configured to use WEP, the VSC can only support legacy a/b/g traffic. (Except on the MSM422, where WEP is not supported when the radio is configured for 802.11n.)

Key source

This option determines how the WEP keys are generated: dynamic or static key.

- **Dynamic:** This is a dynamic key that changes each time the user logs in and is authenticated.

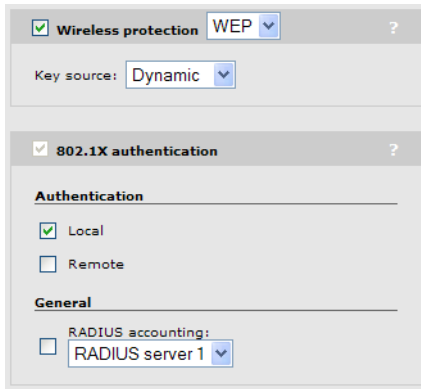

The key is generated via the configured **802.1X authentication** method. Therefore, when you enable this option, the **802.1X authentication** feature is automatically enabled.

- **Static key:** This is a static key that you must define.

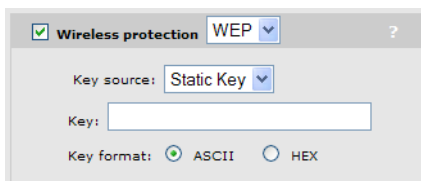

- **Key:** The number of characters you specify for the key determines the level of encryption. For 40-bit encryption, specify 5 ASCII characters or 10 HEX digits. For 128-bit encryption, specify 13 ASCII characters or 26 HEX digits.

When encryption is enabled, wireless stations that do not support encryption cannot communicate with the AP. The definition for each encryption key must be the same on the AP and all client stations.

- **Key format:** Select the format used to specify the encryption key:
 - **ASCII:** ASCII keys are much weaker than carefully chosen HEX keys. You can include ASCII characters between 32 and 126, inclusive, in the key. However, note that not all client stations support non-alphanumeric characters such as spaces, punctuation, or special symbols in the key.
 - **HEX:** Your keys should only include the following characters: 0-9, a-f, A-F

802.1X authentication

This option enables you to use 802.1X to authenticate wireless and wireless users. For configuration details, see [“Configuring 802.1X support on a VSC” \(page 336\)](#).

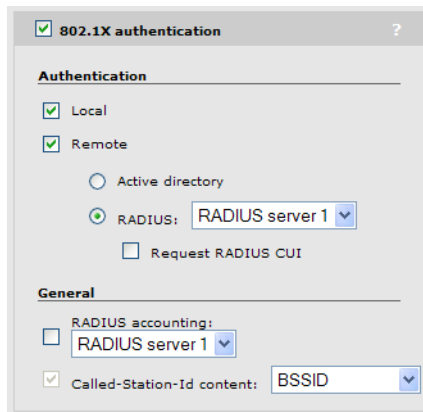

RADIUS authentication realms

When realms are enabled for accounting or authentication, selection of the RADIUS server to use is based on the realm name. If no match is found, then the configured RADIUS profile name is used. This applies to any VSC authentication or accounting setting that uses a RADIUS server.

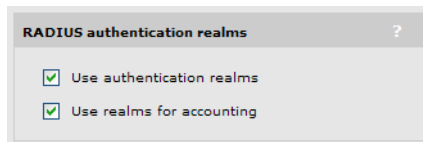

Realm names are extracted from user names as follows: if the username is `person1@mydomain.com` then `mydomain.com` is the realm. The authentication request is sent to the RADIUS profile with the realm name `mydomain.com`. The username sent for authentication is still the complete `person1@mydomain.com`.

For added flexibility, regular expressions can be used in realm names, enabling a single realm name to match many users. For example, if a realm name is defined with the regular expression `^abc.*` then all usernames beginning with **abc** followed by any number of characters will match. The following usernames would all match:

`abc123.biz`

`abc321.lan`

`abc1`



IMPORTANT:

- Realms are not case sensitive.
- Realms have a maximum length of 64 characters.
- A maximum of 200 realms can be defined across all profiles. However, there is no limit per profile.
- Each RADIUS profile can be associated with one or more realms. However, a realm cannot be associated with more than one profile.
- A realm overrides the authentication RADIUS server only; the server used for accounting is not affected.
- A realm overrides the authentication RADIUS server only. The server used for accounting is not affected.
- When the realm configuration is changed in any way, all authenticated users are logged out.

HTML-based user logins

This option defines settings for users who log in to the public access interface using a Web browser. If you disable this option, the public access interface login page is not shown to these users. However, login is still possible via other methods such as MAC authentication and 802.1X.

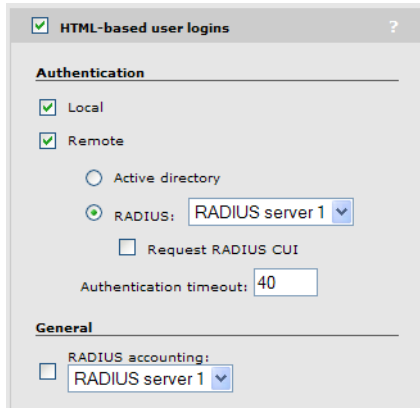

The screenshot shows the configuration window for HTML-based user logins. The window title is "HTML-based user logins" with a checkmark and a help icon. It is divided into two sections: "Authentication" and "General".

Authentication

- Local
- Remote
 - Active directory
 - RADIUS: RADIUS server 1
 - Request RADIUS CUI

Authentication timeout: 40

General

- RADIUS accounting: RADIUS server 1

For configuration details, see [“Configuring HTML-based authentication on a VSC” \(page 348\)](#).

NOTE: The global MAC-based authentication feature only applies on VSCs that have HTML-based user logins enabled. See [“Configuring global MAC-based authentication” \(page 341\)](#).

VPN-based authentication

VPN-based authentication can be used to provide secure access for client stations on VSCs that do not have encryption enabled.

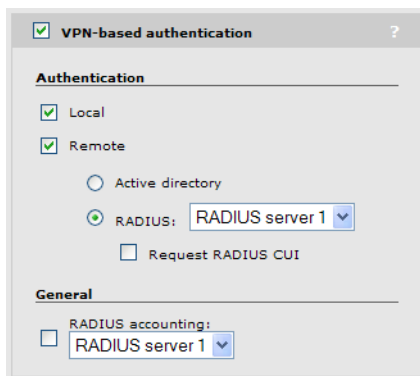

The screenshot shows the configuration window for VPN-based authentication. The window title is "VPN-based authentication" with a checkmark and a help icon. It is divided into two sections: "Authentication" and "General".

Authentication

- Local
- Remote
 - Active directory
 - RADIUS: RADIUS server 1
 - Request RADIUS CUI

General

- RADIUS accounting: RADIUS server 1

For configuration details, see [“Configuring VPN-based authentication on a VSC” \(page 350\)](#).

MAC-based authentication

This option can be used to authenticate both wireless and wired users, depending on how the VSC is configured. To configure this options, see [“Configuring MAC-based authentication on a VSC” \(page 342\)](#).

This option cannot be used at the same time as HTML-based authentication. If you want to use both MAC-based authentication and HTML-based authentication at the same time, use the global MAC-based authentication option See [“MAC-based authentication” \(page 339\)](#).

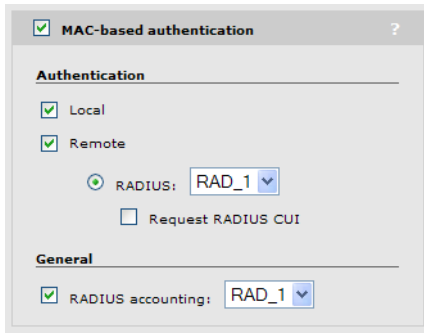

Location-aware

This option enables you to control logins to the public access network based on the AP, or group of APs, to which a user is connected. It is automatically enabled when a VSC is set to **Access control**.

Location-aware is always enabled when using the controller for authentication or access-control with a remote RADIUS server.

For each user login, location-aware sends the PHY Type, SSID, and VLAN to the remote RADIUS server. It also includes the specified **Called-Station-Id content**. For more information, see [“Location-aware authentication” \(page 432\)](#).

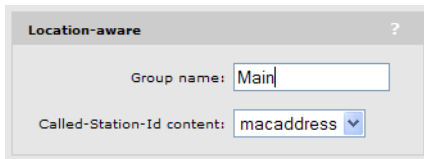

Wireless MAC filter

This option enables you to control access to the wireless network based on the MAC address of a device. Select the MAC address list to use. Each list can contain up to 256 MAC addresses. You can either block access or allow access, depending on your requirements. To configure this option, see [“Configuring MAC-based filters on a VSC” \(page 344\)](#).

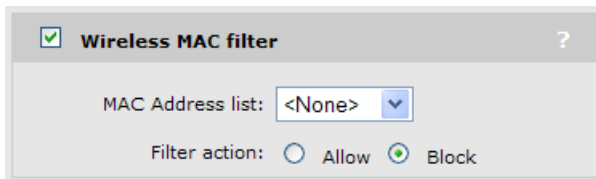

The following table describes how the MAC filter functions when it is used alone and in combination with other authentication options:

Client address	Filter action	When used alone	When used with MAC-based authentication	When used with 802.1X authentication
Client address is in the MAC address list.	Allow	Access is granted.	Access is granted. MAC-based authentication is not performed.	Access is granted or denied based on result of 802.1X authentication.
Client address is in the MAC address list.	Block	Access is denied.	Access is denied. MAC-based authentication is not performed.	Access is denied.

Client address	Filter action	When used alone	When used with MAC-based authentication	When used with 802.1X authentication
Client address is not in the MAC address list.	Allow	Access is denied.	Access is granted or denied based on result of MAC-based authentication. (Not supported on access-controlled VSCs.)	Access is granted or denied based on result of 802.1X authentication.
Client address is not in the MAC address list.	Block	Access is granted.	Access is granted or denied based on result of MAC-based authentication.	Access is granted or denied based on result of 802.1X authentication.

Wireless IP filter

When this option is enabled, the VSC only allows wireless traffic that is addressed to an IP address that is defined in the list. All other traffic is blocked, except for:

- DNS queries (i.e., TCP/UDP traffic on port 53)
- DHCP requests/responses

A maximum of two addresses can be defined. Each address can target a specific device or a range of addresses.

Examples

To only allow traffic addressed to a gateway at the address 192.168.130.1, define the filter as follows:

- Address = 192.168.130.1
- Mask = 255.255.255.255

To only allow traffic addressed to the network 192.168.130.0, define the filter as follows:

- Address = 192.168.130.0
- Mask = 255.255.255.0

DHCP server

This option is only available if the controller is configured as a DHCP server on the **Controller >> Network > Address allocation** page.

A separate DHCP server can be enabled on each VSC to provide custom addressing that is different from the base DHCP subnet that is determined by the LAN port IP address.

To receive traffic from users, the controller assigns the **Gateway** address you specify to its LAN port.

NOTE: These configuration options do not appear for the default VSC. The default VSC uses the same settings as defined on the **Controller >> Network > Address allocation** page.

DHCP relay agent

This option is only available if the controller is currently configured as a DHCP relay agent on the **Controller >> Network > Address allocation** page. Refer to “[Configuring the DHCP relay agent](#)” (page 48).

A separate DHCP relay agent can be enabled on each VSC to provide custom addressing to users.

NOTE: These DHCP relay agent options do not appear for the default VSC. The default VSC uses the same settings as defined on the **Controller >> Network > Address allocation** page.

VSC data flow

Each VSC provides a number of configurable options, some of which apply exclusively on controlled APs or the controller. The following diagrams illustrate how traffic from wireless users is handled by VSC definitions on a controlled AP and controller, and shows the options that apply on each device. For more on traffic flow, see “[Traffic flow for wireless users](#)” (page 221).

Access control enabled

This diagram shows traffic flow when an access-controlled VSC is bound to an AP.

Access control enabled

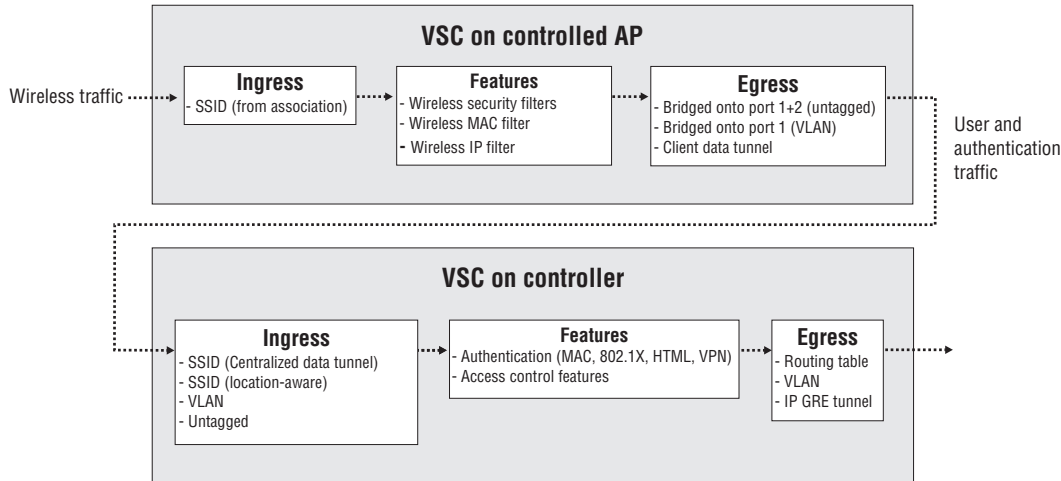

VSC on controlled AP

Ingress

The AP only handles traffic from wireless users, except for the HP 517 and MSM317 which can handle traffic from both wireless and wired users. The SSID is the name of the wireless network with which the user associates.

Features

- **Wireless security filters:** Enables the AP to block traffic unless it is addressed to a specific destination, such as the controller. See [“Wireless security filters” \(page 126\)](#).
- **Wireless MAC filter:** Enables the AP to allow or deny access to the wireless network for specific wireless user MAC addresses.
- **Wireless IP filter:** Enables the AP to only allow wireless-to-wired LAN traffic for specific destination IP addresses.

Egress

- **Bridged onto port 1+2 (untagged):** Untagged user and authentication traffic is bridged onto ports 1 and 2.
- **Bridged onto port 1 (VLAN):** VLAN tagged traffic is bridged onto port 1 only. VLAN tags can be assigned on a per-user basis via RADIUS attributes (see [“Defining account profiles” \(page 357\)](#)), or for all traffic on a VSC (see [“Assigning egress VLANs to a group” \(page 170\)](#)).
- **Client data tunnel:** When this option is enabled, the AP creates a data tunnel to the controller to carry all user traffic. See [Client data tunnel](#).

For a more detailed explanation on how wireless traffic is routed between an AP and controller, see [“Traffic flow for wireless users” \(page 221\)](#).

VSC on controller

Ingress

- **SSID (Client data tunnel):** When a client data tunnel has been created between the AP and the controller, all user traffic comes in on it. See [Client data tunnel](#). The tunnel is established using same interface on which the AP was discovered. (LAN or Internet port).
- **SSID:** SSID is retrieved using the location-aware function.
- **VLAN (LAN or Internet port):** Traffic with a VLAN ID is handled by the VSC with a matching VLAN definition. See [“Using multiple VSCs” \(page 138\)](#).
- **Untagged (LAN port):** Untagged traffic on the LAN port may originate from wired users, or MSM APs operating in autonomous mode.

Features

- **Authentication:** The controller supports 802.1X, MAC, or HTML authentication. To validate user login credentials the controller can use the local user accounts or make use of third-party authentication servers (Active Directory and/or RADIUS). See [“User authentication, accounts, and addressing” \(page 331\)](#).
- **Access control features:** The controller provides a number of features that can be applied to user sessions. Features can be enabled globally or on a per-account basis. See [“Account profiles” \(page 351\)](#).

Egress

The controller enables user traffic to be forwarded to different output interfaces, which include the routing table, VLAN ID, or GRE tunnel. See [“VSC egress mapping” \(page 123\)](#).

Access control disabled

This diagram shows traffic flow when a non-access-controlled VSC is bound to an AP.

Access control disabled

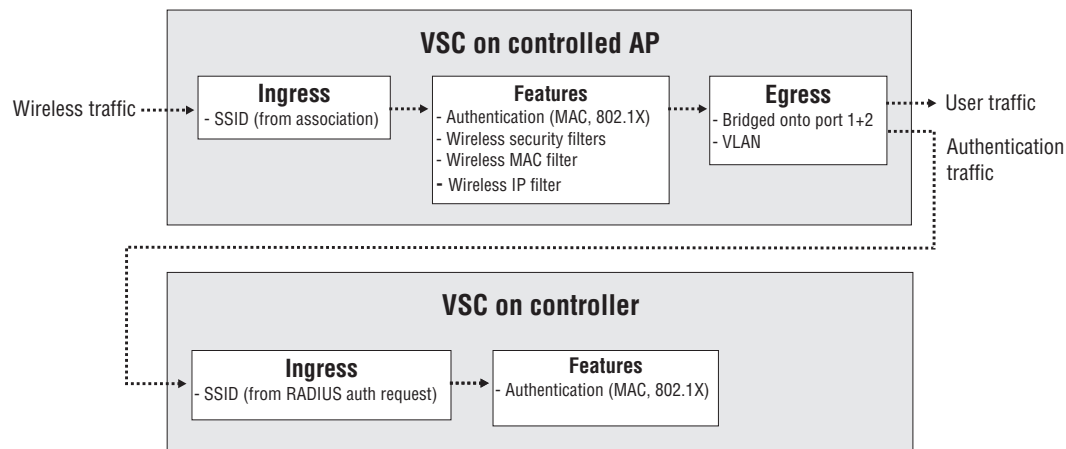

VSC on controlled AP

Ingress

The AP only handles traffic from wireless users, except for the HP 517 and MSM317 which can handle traffic from both wireless and wired users. The SSID is the name of the wireless network with which the user associates.

Features

- **Authentication:** The AP supports 802.1X or MAC authentication. To validate user login credentials the AP makes use of a third-party authentication server (controller or third-party RADIUS server). See [“User authentication, accounts, and addressing” \(page 331\)](#).
- **Wireless security filters:** Enables the AP to block traffic unless it is addressed to a specific destination (like the controller). See [“Wireless security filters” \(page 126\)](#).
- **Wireless MAC filter:** Enables the AP to allow or deny access to the wireless network based on specific wireless user MAC addresses.
- **Wireless IP filter:** Enables the AP to only allow wireless-to-wired LAN traffic for specific destination IP addresses.

Egress

- **Bridged onto port 1+2:** Unless a centralized mode tunnel has been established, user and authentication traffic is bridged onto ports 1 and 2.
- **VLAN:** VLAN tags can be assigned for all traffic on a VSC. See [“Assigning egress VLANs to a group” \(page 170\)](#).

VSC on controller

Ingress

- **SSID (from RADIUS auth request):** The controller determines the SSID from the RADIUS authentication request sent by the AP, and uses this SSID to determine the VSC to use for authentication.

Features

- **Authentication:** The controller supports 802.1X or MAC authentication. To validate user login credentials the controller can use the local user accounts or make use of third-party authentication servers (Active Directory and/or RADIUS). See [“User authentication, accounts, and addressing” \(page 331\)](#).

Using multiple VSCs

When multiple VSCs are defined, it is important to know how user traffic is matched to a VSC definition. When VSCs have access control enabled, incoming traffic is handled on the controller as follows:

Incoming traffic properties	Port	If ...	Then ...
SSID and untagged	LAN	VSC with matching SSID exists.	Traffic is sent on the egress mapping defined on the matching VSC.
		No VSC with matching SSID exists.	Traffic is sent on the egress mapping defined on the default VSC.
SSID and VLAN or VLAN only	LAN or Internet	VSC with matching Ingress VLAN exists.	Traffic is sent on the egress mapping defined on the matching VSC.
		VLAN exists in VLAN table (but is not assigned to a VSC ingress).	Traffic is routed according to the global routing table.

Incoming traffic properties	Port	If ...	Then ...
		No VLAN exists.	Traffic is blocked.
Untagged	LAN		Traffic is sent on the egress mapping defined on the default VSC.

About the default VSC

The default VSC is automatically created by the controller. It is identified with the label (*Default*) in the VSC list. Initially, this VSC is named **HP** and has the following properties:

- Wireless network name: **HP**
- **Use Controller for Authentication** is enabled. (If you disable this option, the controller will not provide user authentication services for 802.1X, WPA, WPA2, or MAC-based.)
- **Use Controller for Access control** is enabled. (If you disable this option, you disable the public access interface and all users gain access to the protected network.)
- HTML-based authentication is enabled.

This means that when a user connects to the default VSC:

- Unauthenticated users cannot access the protected network, except for: `procurve.com` (for product registration) and `windowsupdate.com` (for IE, which tries to get to a windows update on a fresh start).
- Authenticated users can access all protected network resources.

VSC: All VSC profiles		Ingress		Egress		Encryption			Authentication		
Name	SSID	VLAN	GRE	VLAN	TKIP	AES	WEP	802.1x	MAC	HTML	
HP (Default)	HP	-	-	-	-	-	-	-	-	✓	

Add New VSC Profile...

Access controlled (green circle with checkmark)
 SSID Off (red X)
 SSID On (blue circle with checkmark)
 SSID On and configured for broadcast (blue circle with checkmark and plus)

Traffic from wired users is always handled by the default VSC as follows:

- **When access control is disabled on the default VSC**, traffic from wired users connected to the controller LAN port is blocked.
- **When access control is enabled on the default VSC**, traffic from authenticated wired users connected to the controller LAN port is sent on the egress mapping defined on the default VSC. If HTML and 802.1X based authentication methods are disabled, traffic from all users is sent on the egress mapping without the need for authentication.

Quality of service

The quality of service (QoS) setting (under Virtual AP in a VSC) provides a number of different mechanisms to prioritize wireless traffic sent to wireless client stations. This is useful when the controller handles wireless traffic from multiple devices (or multiple applications on a single device), that have different data flow requirements.

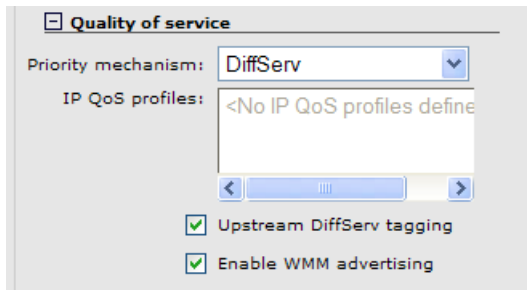

The QoS feature defines four traffic queues based on the Wi-Fi Multimedia (WMM) access categories. In order of priority, these queues are:

Queue	WMM access category	Typically used for
1	AC_VO	Voice traffic
2	AC_VI	Video traffic
3	AC_BE	Best effort data traffic
4	AC_BK	Background data traffic

Outgoing wireless traffic on the VSC is assigned to a queue based on the selected priority mechanism. Traffic delivery is based on strict priority (per the WMM standard). Therefore, if excessive traffic is present on queues 1 or 2, it will reduce the flow of traffic on queue 3 and queue 4.

Regardless of the priority mechanism that is selected:

- Traffic that cannot be classified by a priority mechanism is assigned to queue 3.
- SVP (SpectraLink Voice Protocol) traffic is always assigned to queue 1, except if you select the VSC-based priority mechanism, in which case SVP traffic is assigned to the configured queue.

Priority mechanisms

Priority mechanisms are used to classify traffic on the VSC and assign it to the appropriate queue. The following mechanisms are available:

802.1p

This mechanism classifies traffic based on the value of the VLAN priority field present within the VLAN header.

Queue	802.1p (VLAN priority field value)
1	6, 7
2	4, 5
3	0, 3
4	1, 2

VSC-based priority

This mechanism is unique to HP. It enables you to assign a single priority level to all traffic on a VSC. If you enable the VSC-based priority mechanism, it takes precedence regardless of the priority

mechanism supported by associated client stations. For example, if you set VSC-based low priority, then all devices that connect to the VSC have their traffic set at this priority, including SVP clients.

Queue	VSC-based priority value
1	VSC-based Very High
2	VSC-based High
3	VSC-based Normal
4	VSC-based Low

DiffServ (Differentiated Services)

This mechanism classifies traffic based on the value of the Differentiated Services (DS) codepoint field in IPv4 and IPv6 packet headers (as defined in RFC2474). The codepoint is composed of the six most significant bits of the DS field.

Queue	DiffServ (DS codepoint value)
1	111000 (Network control) 110000 (Internetwork control)
2	101000 (Critical) 100000 (Flash override)
3	011000 (Flash) 000100 (Routine)
4	010000 (Immediate) 001000 (Priority)

TOS

This mechanism classifies traffic based on value of the TOS (Type of Service) field in an IP packet header.

Queue	TOS (Type of Service field value)
1	0x30, 0xE0, 0x88, 0xB8
2	0x28, 0xA0
3	0x08, 0x20
4	All other TOS traffic

IP QoS

This option lets you assign traffic to the queues based on the criteria in one or more IP QoS profiles. Each profile lets you target traffic on specific ports or using specific protocols.

Disabled

When QoS traffic prioritization is disabled, all traffic is sent to queue 3.

IP QoS profiles

This option is only available if you set the **Priority mechanism** to **IP QoS**.

Select the IP QoS profiles to use for this profile. To add QoS profiles to the list, use the **Controller >> Network > IP QoS** page.

Up to 10 profiles can be selected. To select more than one profile, hold down the CTRL key as you select profile names in the list.

To define an IP QoS profile, see [“Configuring IP QoS profiles” \(page 65\)](#).

Upstream DiffServ tagging

Enable this option to have the AP apply differentiated services marking to upstream traffic.

Layer 3 upstream marking ensures end-to-end quality of service in your network. Data originating on the wireless network can now be carried throughout the network (wireless *and* wired) with a consistent quality of service and priority. This feature is enabled by default.

When this feature is enabled, packets received on the wireless interface that include Wi-Fi Multimedia (WMM) QoS values are remarked using IP DiffServ values when transmitted to the wired network. (Remarking is only done for packets that have a DiffServ value of 0. The original DiffServ value from the wireless client is preserved for all other packets.)

Upstream/downstream traffic marking

Depending on the priority mechanism that is active, upstream and downstream traffic is marked as described in this section.

Upstream traffic marking

This table describes the marking applied to wireless traffic sent by connected client stations to an AP and then forwarded onto the wired network by the AP.

Mechanism	INCOMING TRAFFIC Wireless traffic sent from client stations to the AP	OUTGOING TRAFFIC Traffic sent by the AP to the network		
		L2 marking	L3 marking	
			Upstream DiffServ tagging is enabled	Upstream DiffServ tagging is disabled
802.1p	WMM	802.1p (Requires an egress VLAN to be defined for the VSC.) If L3 marking is enabled and the L3 marking value is higher than the L2 marking value, then the L3 marking value is used for L2 marking.	DiffServ (Remarking is only done for packets that have a DiffServ value of 0, otherwise the original value is preserved.)	Pass-through (Original layer 3 marking, if any, is preserved.)
DiffServ	DiffServ		Pass-through (Original layer 3 marking, if any, is preserved.)	
TOS	TOS		Pass-through (Original layer 3 marking, if any, is preserved.)	
VSC-based	WMM, Non-WMM		Uses the selected VSC-based value (very high, high, normal, low).	
IP QoS	WMM		Pass-through (Original layer 3 marking, if any, is preserved.)	

Downstream traffic marking

This table describes the marking applied to traffic received from the wired network by an AP and then sent to connected wireless client stations.

Mechanism	INCOMING TRAFFIC Traffic received from wired network	OUTGOING TRAFFIC Wireless traffic sent from the AP to client stations	
		WMM Client	Non-WMM Client
802.1p	802.1p	WMM + HPQ (WMM marking done according to the rules for the mechanism.)	HPQ (hardware priority queueing)
DiffServ	DiffServ		
TOS	TOS		
VSC-based	All traffic on the VSC.		
IP QoS	All traffic that matches the ports/protocols specified in the selected IP QoS profiles.		

NOTE: Although the WMM specification refers to 802.1D and not 802.1p, this guide uses the term 802.1p because it is more widely recognized. (The updated IEEE 802.1D: ISO/IEC 15802-3 (MAC Bridges) standard covers all parts of the Traffic Class Expediting and Dynamic Multicast Filtering described in the IEEE 802.1p standard.)

QoS example

In this example, a single controller provides voice and data wireless support with different quality of service settings for guests and employees.

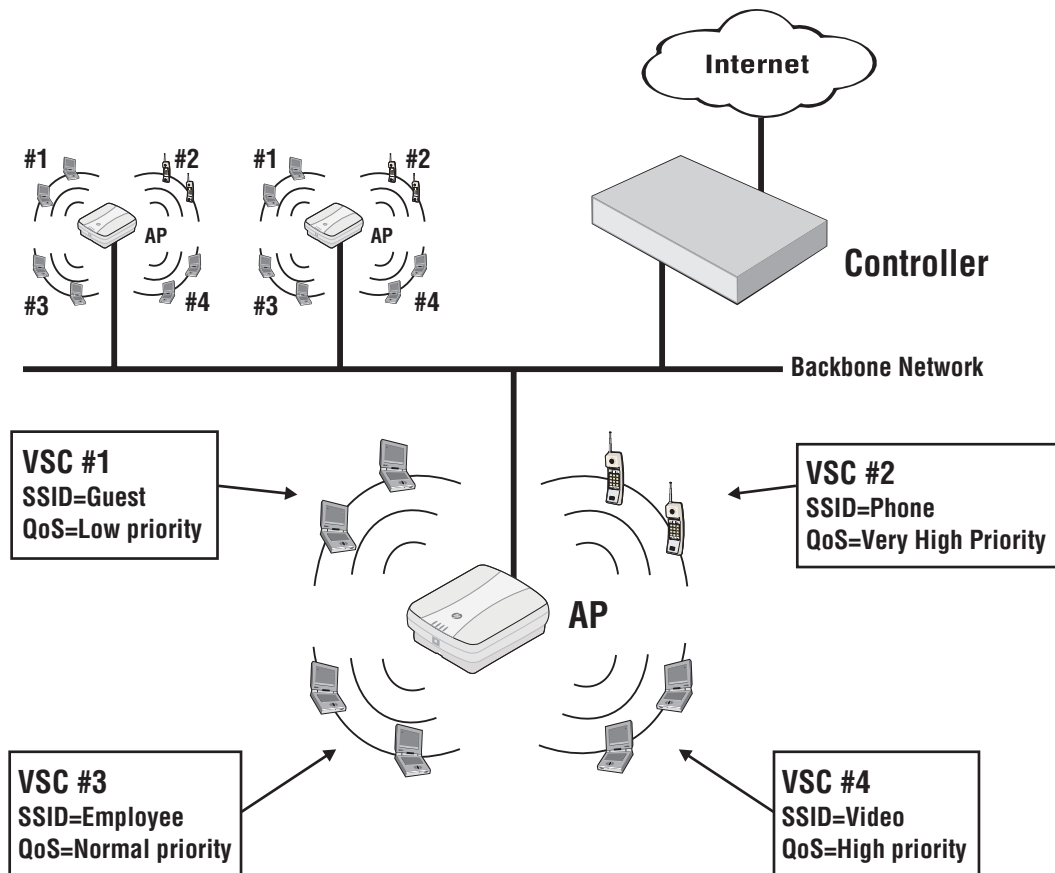

Creating a new VSC

To add a VSC, select **Controller > VSCs >>VSC Profiles > Add New VSC Profile**.

Define VSC parameters and select **Save**. Familiarize yourself with sections of interest in “[VSC configuration options](#)” (page 113). See the online help for parameter descriptions.

Assigning a VSC to a group

When working with controlled APs, VSC definitions must be bound to a group so that they will automatically be activated on the APs in the group. For information on how to bind (assign) a VSC to a group, see “[Binding a VSC to a group](#)” (page 165).

On an HP 517 or MSM317, VSCs can also be bound to a switch port. See the *HP 517 802.11ac Unified Walljack Configuration Guide* and the *MSM317 Access Device Installation and Configuration Guide*.

NOTE: When working with autonomous APs, the VSC definition you create on the controller must be manually configured on each autonomous AP. See “[Working with autonomous APs](#)” (page 533) and the *MSM3xx/MSM4xx Access Points Configuration Guide*.

8 Working with controlled APs

Key concepts

The controller provides centralized management of APs operating in controlled mode. Controlled mode greatly simplifies the set up and maintenance of a Wi-Fi infrastructure by centralizing the configuration and management of distributed APs.

NOTE: Starting with software version 5.x, APs operate in controlled mode by default. If you update an AP from an earlier release, the AP boots in autonomous mode. Subsequently resetting the AP to factory defaults switches it to controlled mode. For details on working with autonomous APs, see [“Working with autonomous APs” \(page 533\)](#), and [“Resetting to factory defaults” \(page 547\)](#).

Plug and play installation

In most cases, initial configuration of an AP is not required. Simply power it up and plug it into a network that provides access to a controller. The AP will automatically discover and authenticate itself with the controller. The AP does not offer wireless services until it successfully connects and synchronizes with a controller. Layer 3 networks may require the APs first to be provisioned.

Automatic software updates

Once an AP establishes a management tunnel with a controller its software is automatically updated to match the version installed on the controller.

Centralized configuration management

All AP configuration settings are defined using the controller management tool and are automatically uploaded to all controlled APs with a single mouse select. For added flexibility, APs can be assigned to groups, enabling each group to have customized configuration settings. If needed, the individual settings for each AP in a group can also be customized.

Manual provisioning

By default, APs operating in controlled mode will automatically discover and connect with a controller on most network topologies. However, in certain cases it may be necessary to manually configure (provision) connectivity and discovery options. Manual provisioning can be done directly on the AP, or via the controller. When using the controller, provisioning can be applied to entire groups making it easy to customize many APs at once. When working with a controller team, APs must be provisioned to discover each team member to ensure that failover is supported. The APs must be able to migrate to a new team member if the current team member with which they are associated becomes unavailable.

Secure management tunnel

Once authenticated, a secure management tunnel is established between the AP and the controller to support the exchange of management traffic between the two devices.

AP authentication

The controller can be configured to authenticate APs by their MAC address before they are managed. The authentication can be defined locally on the controller, via a third-party RADIUS server, or using a remote text-based control file. Another method is to use authentication during discovery option. See [“Discovery authentication” \(page 176\)](#) and [“Discovery authentication” \(page 154\)](#).

AP licensing

For every controlled AP that will be managed by the controller, you must install a valid AP license. The exception to this rule is the MSM317. Any number of MSM317s can be managed by a controller up to the maximum number of APs that it supports. See [“License management” \(page 542\)](#). To view the current status of AP licensing limits, select **Controller >> Status > AP limits**. The AP limits page opens. For example, the following screen capture shows an MSM720 with two controlled MSM317s:

The screenshot shows the 'AP limits' page with a 'Current limits' box containing the following information:

- Maximum managed APs: 40
- Maximum configured APs: 120
- Total AP licenses: [10](#)

Below this information is a table with the following data:

Product	In use	Remaining
Access devices (MSM317)	2	38
Authenticated APs	0	10











The totals on this page are automatically calculated based on the capacity of the controller and the number of installed AP licenses.





- **Maximum managed APs:** Maximum number of active APs that can be managed by this controller at any given time. This includes all licensed APs and the MSM317 (which does not require an AP license).
- **Maximum configured APs:** Maximum number of APs that can be configured on this controller. (The controller can store configuration information for APs that are currently not actively being managed.)
- **Total AP licenses:** Total of all AP licenses installed on the **Controller >> Maintenance > Licenses** page. The controller can manage any number of APs up to this limit. (Management of the MSM317 does not require a license, therefore this AP is not included when calculating licensing limits.)
- **Table:** The table provides the current status of all licenses and limits for all APs. The **In use** column displays the total number of APs that are currently being managed. The **Remaining** column displays the total number of APs that can still be added.

Key controlled-mode events

The following diagram provides an overview of key events that occur when working with APs in controlled mode.

Controller		AP
Deploy the controller.		
↓		

Controller		AP
<p>Configure AP authentication. For security purposes, the controller can require that APs be authenticated before they can be managed.</p> <ul style="list-style-type: none"> See “Authentication of controlled APs” (page 159). <p>Set up groups. Groups allow you to apply the same configuration settings to many APs at the same time. You can create multiple groups, allowing you to maintain distinct settings for different types of APs. If no groups are created, all APs are assigned to a default group.</p> <ul style="list-style-type: none"> See “Configuring APs” (page 162). 		<p>Deploy an AP with its default configuration OR manually provision initial AP configuration.</p> <p>On most network topologies, if you deploy an AP with factory default settings it will automatically find and connect with a controller on the network.</p> <p>In some cases, it may be necessary or desirable to provision an AP before it is deployed to ensure that discovery is successful, or to force a specific discovery option.</p> <p>The AP does not offer wireless services until it discovers and connects with a controller.</p> <ul style="list-style-type: none"> See “Provisioning APs” (page 171).
		
<p>The controller receives a discovery request.</p>		<p>When started, the AP attempts to discover all controllers that are operating on the local network.</p> <ul style="list-style-type: none"> See “Discovery of controllers by controlled APs” (page 148).
		
<p>The controller sends a discovery reply. (If the AP authentication option is enabled, the AP needs to be authenticated first.)</p> <ul style="list-style-type: none"> See “Discovery of controllers by controlled APs” (page 148). 		<p>AP receives discovery reply. If more than one reply is received, the AP chooses the controller with the highest priority setting.</p> <ul style="list-style-type: none"> See “Discovery of controllers by controlled APs” (page 148).
		
<p>Controller adds the AP to a group. This will either be the default group (if the AP is new/unknown) or an existing group (to which the AP was previously assigned).</p> <ul style="list-style-type: none"> See “Configuring APs” (page 162). 		<p>AP joins with the selected controller.</p>
		
<p>If AP software is out of date, controller tells the AP to update its software.</p>		<p>AP fetches the software from the controller, installs it, and then restarts itself. Discovery is performed again.</p>
		

Controller		AP
Controller accepts the secure management tunnel.		AP establishes secure management tunnel with the controller.
		
The controller updates the AP configuration.		AP receives new software and configuration.
		
		Discovery complete. Wireless services become available. On the HP 517 and MSM317, the switch ports also become active.

Discovery of controllers by controlled APs

This section describes how the discovery process works and how it can be customized.

Discovery is the process by which a controlled AP finds a controller (or controller team) on a network and establishes a secure management tunnel with it. To see how the discovery process fits into overall controlled mode operations, see [“Key controlled-mode events” \(page 146\)](#).

In most cases, the factory default configuration of an AP will result in automatic discovery of a controller with no configuration required. However, for some network topologies it may be necessary to configure the discovery process as described in this section.

See [“Discovery recommendations” \(page 151\)](#) for examples of topologies that can use automatic discovery and those that require discovery to be configured.

NOTE:

Provisioning can limit the discovery of potential controllers. See [“Provisioning APs” \(page 171\)](#).

Discovery overview

Although the specifics of the discovery process vary depending on whether an AP is *unprovisioned* (in its factory default state) or *provisioned* (had its connectivity or discovery settings changed from their factory default settings), the discovery process can be summarized as follows:

1. The AP uses various methods to locate one or more controllers that are reachable on the network. The preferred way to monitor AP discovery is via the controller management tool (see [“Monitoring the discovery process” \(page 154\)](#)). When in visual range of the APs, you can watch the status lights for an indication of discovery progress. See the status light information in the AP Quickstart (provided and available online).
2. Discovered controllers send a discovery reply to the AP. If the controller is configured to require AP authentication, the reply is only sent after the AP is authenticated by the controller.
3. The controller adds the AP to a group. This will either be the default group (if the AP is new/unknown) or an existing group (to which the AP was previously assigned).

- The AP is now managed by the controller, and it can be configured and monitored using the controller management tool.

NOTE:

- APs must be connected to the network via Port 1 (or the Uplink port on an HP 517 or MSM317) for discovery to work.
- Unprovisioned APs must obtain an IP address from a DHCP server before discovery can be initiated. When discovery occurs on a VLAN, the DHCP server must be active on the VLAN.

Discovery is performed whenever an AP:

- Is restarted (or reset to factory defaults)
- Loses connectivity with its controller
- Is removed and rediscovered using an action on the **Controlled APs >> Overview > Discovered APs** page.

Discovery methods

Four discovery methods are available. The following table summaries their features and recommended applications.

Method	Description	Supported by	Suggested use
UDP broadcast	AP issues UDP broadcasts to discover controllers on the same subnet.	Unprovisioned APs	Both the controller and AP reside on the same subnet.
DHCP	AP obtains controller address from a specially configured DHCP server.	Unprovisioned APs	The AP is on a different subnet than the controller.
DNS	AP obtains controller address from a DNS server using predefined host names.	Unprovisioned APs Provisioned APs	The AP is on a different subnet than the controller.
Specific IP addresses	AP connects to a specific controller using a list of pre-configured static IP addresses.	Provisioned APs	DHCP and DNS are not used and the AP is on a different subnet than the controller.

NOTE: A controller listens for discovery requests on the interfaces configured on the **Controller >> Management > Device Discovery** page. (See [“Discovery priority” \(page 152\)](#)).

UDP broadcast discovery

The AP sends a UDP broadcast to discover all controllers that are on the same subnet as the AP.

DHCP discovery

When configured as DHCP client (which is the factory default setting for all APs), an AP can obtain the IP addresses of controllers on the network from any DHCP server configured to support the Colubris Vendor Class (DHCP option 43).

Vendor Class enables an administrator to define a list of up to five available controllers on the network to which APs can connect.

- If the controller is configured to operate as the DHCP server for the network, you can define the list of available controllers by selecting **Controller >> Network > Address allocation > DHCP server** and then configure the **Controller discovery** option.

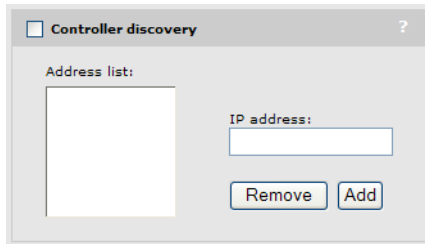

Add the IP address for each controller that is active on the network. When working with a controller team you should add the IP address of each team member.

This list is sent to all devices that request an IP address, encoded as DHCP option 43 (Vendor-specific information). However, this information is only interpreted by HP APs that are operating in controlled mode. Controlled mode APs use these addresses to connect with the controllers in the order that they appear in the list.

- If an external DHCP server is used, it must have **Option 43** configured. For examples on how to configure some popular third-party DHCP servers, see [“DHCP servers and Colubris vendor classes”](#) (page 558).

DNS discovery

DNS discovery is attempted using UDP unicast discovery requests which are issued by the AP to the following default controller names:

- cnsrv1
- cnsrv2
- cnsrv3
- cnsrv4
- cnsrv5

This method enables discovery across various network configurations. It requires that at least one controller name is resolvable via a DNS server.

The AP appends the default domain name returned by a DHCP server (when it assigns an IP address to the AP) to the controller name. For example, if the DHCP server returns `mydomain.com`, then the AP will search for the following controllers in this order:

- cnsrv1.mydomain.com
- cnsrv2.mydomain.com
- cnsrv3.mydomain.com
- cnsrv4.mydomain.com
- cnsrv5.mydomain.com

Discovery using specific IP addresses

Provisioned APs can be configured to connect with a controller at a specific IP address. A list of addresses can be defined, allowing the AP to search for multiple controllers.

This can also be used to strengthen the security on a local network to make sure that the AP goes to a specific controller for management.

Discovery order

Discovery occurs differently for unprovisioned and provisioned APs.

Unprovisioned APs

Once an unprovisioned AP has received its IP address from a DHCP server, it attempts to discover a controller using the following methods, in order:

- UDP broadcast
- DHCP
- DNS

These discovery methods are applied on the following interfaces, in order:

- Last interface on which a controller was discovered. (Only applies to APs that have previously discovered a controller)
- Untagged on Port 1
- All detected VLANs (in sequence) on Port 1

Provisioned APs

If connectivity settings are provisioned on the AP, then the AP uses only the provisioned settings (see [“Provisioning connectivity” \(page 173\)](#)). The following connectivity settings are available on provisioned APs:

- Interface: Wireless port or local mesh link.
- VLAN support: Allows a VLAN to be designated. Discovery will then take place on the VLAN.

NOTE: If discovery is configured to take place on a VLAN over a local mesh link, a second VLAN must be defined to send traffic over the local mesh link. The same VLAN cannot be used to carry the control channel and local mesh traffic.

If discovery settings are provisioned on the AP, then the AP uses only the provisioned settings (see [“Provisioning discovery” \(page 175\)](#)). The following discovery settings are available on provisioned APs:

- DNS discovery: Enables custom controller names and domains to be used for discovery.
- Discovery using specific IP addresses: Enables the AP to find controllers operating at specific IP addresses.

Discovery recommendations

NOTE: When controller teaming is active, controlled APs discover a team in the same way that they discover non-teaming controllers.

- **If the AP is on the same subnet as the controller**, then UDP discovery will work with no configuration required on either the AP or controller. This applies whether the controller is operating as the DHCP server for the network or if a third-party DHCP server is used.
If VLANs are being used, then UDP discovery will also work with no configuration. However, to speed up the discovery process you can provision the AP with a specific VLAN ID. This will eliminate the need for the AP to find and attempt discovery on all available VLANs.
- **If the AP is on a different subnet than the controller**, UDP discovery will not work. Instead, DHCP or DNS discovery must be used, or direct IP address discovery must be provisioned.
- **DHCP discovery:** If you have control of the DHCP server, enable support for the Colubris Vendor Class as explained in [“DHCP discovery” \(page 149\)](#).
 - **DNS discovery:** If you have control of the DNS server, you can configure it to resolve the default controller names that an AP will search for. To use custom names, you must

provision discovery settings on the AP. For more information on using custom names, see [“Provisioning discovery” \(page 175\)](#).

- **Specific IP discovery:** This method needs to be used when you do not have control over the DHCP and DNS servers and no domain is registered to the controller. For example, if the connection to the controller is routed over the public Internet.

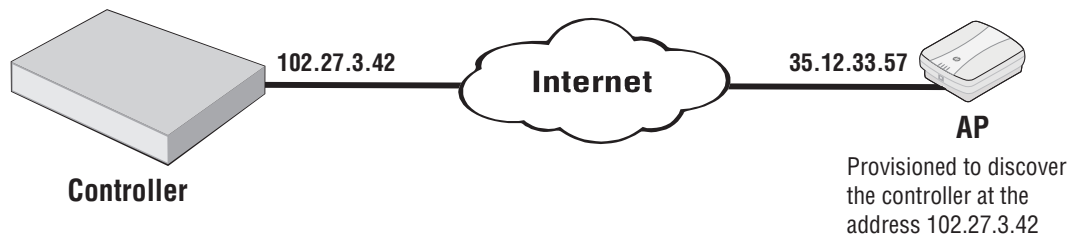

For discovery to succeed, the AP must be provisioned with the controller IP address. See [“Provisioning discovery” \(page 175\)](#).

- **When working with a controller team,** APs should be provisioned to discover all controllers that make up the team, not just the team manager. This is required for proper fail-over operation.

Discovery priority

Each controller or controller team that receives a discovery request sends the requesting AP a discovery reply. If the AP authentication option is enabled, the AP needs to be authenticated first. Requests from unauthenticated APs are ignored.

If an AP receives discovery replies from multiple controllers, the AP selects the controller that has the highest discovery priority setting (1 is the highest priority setting, 16 is the lowest priority setting). If that controller is already managing the maximum number of controlled APs, the AP will choose the controller with the next highest priority.

Non-teamed controllers are always higher priority than controller teams. Therefore, if your network contains both controller teams and non-teamed controllers, APs first attempt to establish a secure management tunnel with discovered non-teamed controllers in order of their discovery priority. Only if all non-teamed controllers are already managing the maximum number of controlled APs will the AP then consider controller teams in the order of their priority.

The following table shows how discovery would occur for several teamed and non-teamed controllers.

Controller or Team	Configured discovery priority setting	Actual order of discovery by APs
Controller 1	1	1
Controller 2	2	2
Controller 3	3	3
Team 1	1	4
Team 2	2	5
Team 3	3	6

If two controllers have the same priority setting, the AP will appear on the **Overview > Discovered APs** page of both controllers with a **Diagnostic** value of **Priority Conflict** (See [“Viewing all discovered APs” \(page 155\)](#)). To resolve the conflict, change the priority setting of one of the controllers on its Discovery page.

Discovery priority is set on a controller using the **Discovery priority of this controller** option on the **Controller >> Management > Device Discovery** page.

On the MSM720

The screenshot shows the 'Discovery' configuration page for an MSM720 controller. It is divided into two main sections: 'Mobility controller discovery' and 'Controlled AP discovery'.
In the 'Mobility controller discovery' section, there is a checkbox for 'This is the primary mobility controller' which is unchecked. Below it is a text input field for the 'IP address of the primary mobility controller'.
In the 'Controlled AP discovery' section, the 'Discovery priority of this controller' is set to '1'. Under 'Active Interfaces', there is a list with two items: 'Internet network (10)' (unchecked) and 'Access network (1)' (checked).
Below the active interfaces is the 'AP authentication' section, which includes two text input fields for 'Shared secret' and 'Confirm shared secret', and a checkbox for 'Authenticate APs' which is unchecked.
A 'Save' button is located at the bottom right of the page.

On all other controllers

This screenshot shows the 'Discovery' configuration page for other controllers. The layout is identical to the MSM720 page, but with different interface selections.
In the 'Controlled AP discovery' section, the 'Active Interfaces' list now has 'LAN Interface' checked and 'Internet Interface' unchecked.
The 'AP authentication' section remains the same as in the previous screenshot, with 'Authenticate APs' unchecked.
A 'Save' button is located at the bottom right of the page.

Active interfaces

Select the physical interfaces on which the controller or team manager will listen for discovery requests from controlled APs. The control channel to an AP is always established on the interface on which it is discovered.

Discovery authentication

Authentication can be enabled during the discovery process to allow a controller and AP to validate each other prior to establishing a control channel. Authentication can be mutual, or can be performed by either the controller or AP, depending on how you define the configuration.

- **Shared secret/Confirm shared secret:** Specify the shared secret that the controller will use when authenticating an AP, or when responding to an authentication request from an AP. For a control channel to be established, the secret you define here must match the one configured for the AP under **Controlled APs >> Provisioning > Discovery > Discovery authentication**. The shared secret must be between eight characters and twenty characters long.
- **Authenticate APs before connecting:** Enable this option to have the controller authenticate an AP before establishing a control channel with it. If you do not enable this option, the AP may still authenticate the controller depending on the settings you make under **Controlled APs >> Provisioning > Discovery > Discovery authentication**.

Discovery considerations

If controlled APs are behind a firewall or NAT device, refer to the following sections.

Firewall

If the network path between an AP and a controller traverses a firewall the following ports must be opened for management and discovery to work:

Protocol	Open these ports	Ports are used by
UDP	Source and destination = 38212 (9544 hex)	Discovery protocol the AP uses to find a controller.
UDP	Destination = 1194 (4AA hex)	Management tunnel that is established between an AP and a controller.
TCP	Source and destination = 1194 (4AA hex)	Software updates and certificate exchanges (for the management tunnel).
UDP	Source and destination = 3001 (BB9 hex)	Client data tunnel.
UDP	Source = 39064 (9898 hex) Destination = 1800 (708 hex), 1812 (714 hex), 1813 (715 hex), 30840 (7878 hex)	Location aware. This is only necessary if autonomous APs are using the access-controlled (public access) interface.

NAT

If the network path between an AP and a controller implements NAT (network address translation), discovery will only work if NAT functions on outbound traffic sent from the AP to the controller. If NAT operates in the other direction, discovery will fail.

Monitoring the discovery process

This Summary menu lists the number of controlled APs discovered by the controller. APs are grouped according to their management state. For example: **Synchronized**, **Detected**, **Configured**, **Pending**.

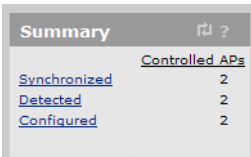

Summary	
Controlled APs	
Synchronized	2
Detected	2
Configured	2

An AP may be active in more than one state at the same time. For example, an AP may be both **Detected** and **Synchronized**. Select the state name to display information about all APs in that state.

Viewing all discovered APs

To display information about APs discovered by the controller, select **Controlled APs >> Overview > Discovered APs**.

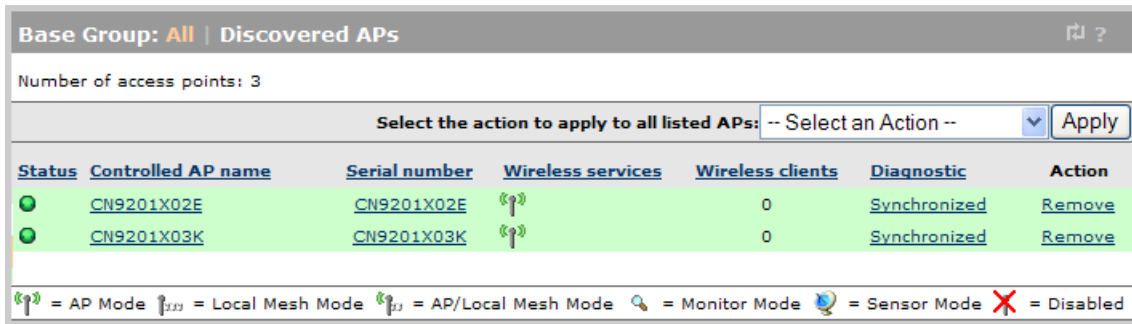

Status	Controlled AP name	Serial number	Wireless services	Wireless clients	Diagnostic	Action
	CN9201X02E	CN9201X02E		0	Synchronized	Remove
	CN9201X03K	CN9201X03K		0	Synchronized	Remove

= AP Mode = Local Mesh Mode = AP/Local Mesh Mode = Monitor Mode = Sensor Mode = Disabled

The **Discovered APs** page provides the following information:

- **Number of access points:** Indicates the number of APs that were discovered.
- **Select the action to apply to all listed APs:** Lets you apply the selected action to all APs in the list. Select an action and then **Apply**.
 - **Authorize Locally:** Use this option to manually authorize an AP. This is useful when AP authentication is enabled on the **Controller >> Controlled APs >> Authentication** page. When this option is enabled, only APs that are defined in an authentication list are automatically authorized. All other APs are flagged as *Not authorized*.
 - **Accept Suspicious:** If an AP submits more than one request for a signed certificate, it is flagged as *Suspicious*. The goal with this strategy is to guard against fake requests from malicious third-party devices. Legitimate APs may also be classified as *Suspicious* when they are reset to factory default, or when switched from controlled mode to autonomous mode and back again. In this case, use this option to accept the AP.
 - **Accept Products:** It is possible to pre-configure APs on the **Controlled APs >> Overview > Configured APs** page. When a preconfigured AP is later discovered, the controller attempts to match the actual product type of the discovered AP with its configured value. If there is a mismatch, the AP is flagged as *Wrong product*. Use this option to replace the configured product type with the actual discovered value.
 - **Synchronize Configuration:** Synchronize configuration settings on the controller on all controlled APs..
 - **Remove and Rediscover:** Removes all discovered APs and re-initiates the discovery process.
- **Status:**
 - **Green:** The AP is synchronized, meaning that the AP is connected, running, and has received its configuration from the controller.
 - **Orange:** The AP is unsynchronized, meaning that the AP is operational but does not have the same configuration as the controller, yet.
 - **Red:** The AP is not part of the controlled network and is not providing wireless services. See the **Diagnostic** column for details.
 - Grey flashing: An action is pending.
 - Grey solid: The AP is configured in a group, but has not been discovered on the network.
- **Controlled AP name:** Name assigned to the AP.

- **Serial number:** Unique serial number assigned to the AP at the factory. Cannot be changed.
- **Wireless services:** Indicates the status of wireless services on the AP. A separate icon appears for each radio on the AP. See the legend under the table for the meaning of each icon.
- **Wireless clients:** Indicates the number of wireless clients currently associated with the AP. Select the number to see more information.
- **Diagnostic:** Indicates the status of the AP with regards to management by the controller, as shown in the following table.

Diagnostic	Description
AP limit exceeded	The maximum number of APs are already being managed by the controller as defined on the Controller >> Status > AP limits page.
Detected	The AP was detected by the controller.
Enabling VSC services	The AP is enabling wireless services for all VSCs.
Establishing tunnel	A secure management connection is being established to the AP.
Firmware failure	New firmware failed to upload to the AP. The controller will retry soon.
Incompatible settings	Local mesh has been provisioned on the AP but: <ul style="list-style-type: none"> ◦ The APs radio is disabled. ◦ The AP radio operating mode does not support local mesh. ◦ The APs radio wireless mode does not match the one provisioned. ◦ The mesh ID is not uniquely assigned.
Installing firmware	New firmware has been successfully uploaded to the AP. Wait until the AP restarts to activate the new firmware.
Not authorized	The AP could not be authenticated by the controller. This may be due to invalid authentication credentials supplied by the AP. (Authentication settings used by the controller are defined on the Controller >> Security > Controlled APs page.) You should accept the AP unless it is an actual rogue.
Not responding	The AP has stopped sending management information to the controller. Rediscovery may re-establish the connection. If not the AP may have lost power or a network failure has occurred.
Priority conflict	More than one controller responded to the AP discovery request with the same priority. The AP is therefore unable to select a controller to function as its controller. The AP will retry its discovery request shortly. You must fix the priority conflict by changing the priority setting for one of the controllers (Controller >> Management > Device discovery).
Waiting for manager	When teaming is active, a newly discovered AP will temporarily be in this state while it waits for the team manager to add it to the Network Tree .
Rebooting	The AP is restarting.
Resetting configuration	The AP configuration is being reset to factory defaults. This is normal and will occur when the firmware version on the controller is changed or if the AP is not synchronized.
Restoring configuration	The AP is currently restoring its previous configuration settings.

Diagnostic	Description
Suspicious device	<p>The AP unexpectedly requested new authentication certificates from the controller. Possible causes are as follows:</p> <ul style="list-style-type: none"> ◦ A previously synchronized AP was reset to factory defaults. ◦ An unauthorized AP may be using the same MAC address. <p>This is a possible security breach that should be investigated before authorizing the AP again.</p>
Synchronized	The AP is up and running, offers wireless services, and had its firmware and configuration settings successfully updated by the controller.
Synchronized/License violation	<p>Although the AP is synchronized it is non-functional (quarantined) due to a license violation.</p> <p>You must change the configuration to omit the affected licensed feature or acquire and install a valid license.</p>
Unconfigurable	This AP cannot be added because the maximum number of configured APs has been reached. To add this AP you must first remove one or more currently configured APs.
Unsupported product	<p>No suitable firmware is available for this AP on the controller.</p> <p>You should upgrade the controller firmware so that the newly-introduced product can be recognized.</p>
Unsynchronized	<p>The AP is up and running and offers wireless services. However, its configuration settings do not match the settings defined on the controller (at the group or AP level).</p> <p>You should Synchronize the AP.</p>
Unsynchronized/License violation	<p>The AP is not synchronized but can continue operation. However, if synchronized, it will become non-functional as described above for Synchronized/License violation.</p> <p>Before synchronizing, either change the configuration to omit the affected licensed feature or acquire and install a valid license.</p>
Uploading configuration	Configuration settings are currently being sent to the AP.
Uploading firmware	The controller is uploading new firmware to the AP. Wait until the operation completes.
Validating configuration	The controller is waiting for the AP to send its configuration.
Validating firmware	The controller is waiting for the AP to send its firmware version number.
Waiting for acceptance	The AP has been authorized by the controller. However, the AP has not yet selected the controller to function as its controller. (If multiple controllers replied to the APs discovery request, the AP may choose to connect with another controller.)
Wrong product	<p>The AP was created with a product type that does not match the detected product type. This can occur when an AP is manually added to a group with the wrong product type.</p> <p>You should verify and fix the product type.</p>
Validating capabilities	The capabilities of the AP are being identified by the controller.

- **Action:** Indicates the recommended administrative action to be taken to resolve a diagnostic condition.

Viewing all configured APs

To display information about APs configured by the controller, select **Controlled APs >> Overview > Configured APs**.

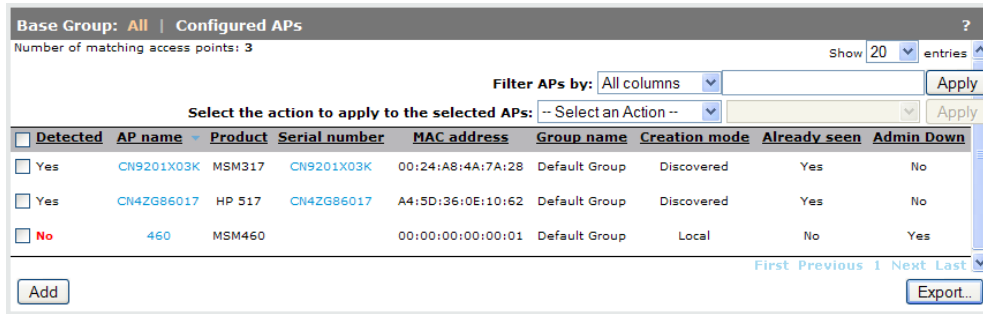

Base Group: All | Configured APs
Number of matching access points: 3
Show 20 entries

Filter APs by: All columns [Apply]

Select the action to apply to the selected APs: -- Select an Action -- [Apply]

<input type="checkbox"/>	Detected	AP name	Product	Serial number	MAC address	Group name	Creation mode	Already seen	Admin Down
<input type="checkbox"/>	Yes	CN9201X03K	MSM317	CN9201X03K	00:24:A8:4A:7A:28	Default Group	Discovered	Yes	No
<input type="checkbox"/>	Yes	CN4ZG86017	HP 517	CN4ZG86017	A4:5D:36:0E:10:62	Default Group	Discovered	Yes	No
<input type="checkbox"/>	No	460	MSM460		00:00:00:00:00:01	Default Group	Local	No	Yes

[Add] [Export...]

The **Configured APs** page provides the following information:

- **Number of displayed access points:** Number of configured APs that were discovered.
- **Filter APs by:** To narrow down the list of APs in the table, select a category and enter text on which to filter the AP list. Select **Apply** to activate the filter. To deactivate the filter, clear the filter text and then select **Apply**.
- **Select the action to apply to the selected APs:**
 - **Move to group:** Select a group from the list and click apply to move all selected APs in the table to that group.
 - **Set admin down to:** Select the value for the Admin Down parameter. Set it to **Yes** to flag an AP that is offline for a known reason (such as maintenance, relocation) to differentiate it from other APs that are offline for unknown reasons (network failure, power failure, or other issues that prevent them from communicating with the controller). APs flagged as Admin Down do not appear in the count of offline APs shown on the dashboard. When an AP comes back online, the Admin Down flag is automatically cleared. Only offline APs can be flagged as Admin Down.
- **Add:** Select this button to manually add an AP.
- **Export:** Select this button to export the list of APs as an XML file for use in other applications. One use for this information is to perform a check between the list of APs discovered by the controller and the list of APs that were physically installed at a location.

The following information is contained in the exported file.

- Serial number
- Ethernet port MAC address
- Model number
- System name
- System location
- System contact
- Configuration group
- Installed

Table

Select the title of a column to sort the entries according to the values in the column.

- **Check boxes:** Use the check box to select an AP to move it to another group. Select the check box in the title bar to select all APs on this page.
- **Detected:**
 - **Yes:** The AP has been discovered and is listed on the AP overview page, where more information is provided on the AP.
 - **No:** The AP has not been discovered.
- **AP name:** Name assigned to the AP. Select the name to open its AP management page.
- **Product:** Product name of the MSM AP.
- **Serial number:** Serial number assigned to the AP. Select the serial number to open its AP management page.
- **MAC address:** MAC address of the MSM AP.
- **Group Name:** Group that the AP is part of.
- **Creation mode:**
 - **Local:** AP was added manually, or was manually authenticated after being discovered.
 - **RADIUS:** AP was successfully authenticated via RADIUS and then created.
 - **External file:** AP was successfully authenticated using the external file option.
 - **Discovered:** Automatically detected by the controller based on discovery-time parameter exchange.
- **Already Seen:** The AP established a management tunnel to the controller at least once in the past.
- **Admin Down:**
 - **Yes:** AP was added manually, or was manually authenticated after being discovered.
 - **RADIUS:** AP was successfully authenticated via RADIUS and then created.
 - **External file:** AP was successfully authenticated using the external file option.
 - **Discovered:** Automatically detected by the controller based on discovery-time parameter exchange.

Authentication of controlled APs

For security purposes, the controller can require that APs be authenticated before they are managed. Authentication is enabled by selecting **Controller >> Controlled APs > Authentication**.

NOTE: The AP authentication option is disabled by default, meaning that all discovered APs are authorized (no authentication is required).

Authentication

General settings

Authentication interval: 720 minutes

Authenticate Now

Use RADIUS authentication list

RADIUS profile: guest

RADIUS username:

RADIUS password:

Confirm RADIUS password:

Use file authentication list

File location:

Use local authentication list

AP name	Serial number	MAC address
B058-00291	B058-00291	00:03:52:07:04:4C
B013-06369	B013-06369	00:03:52:03:F1:D5

Save

The controller authenticates APs using their MAC addresses. When an AP sends a discovery request to the controller, it includes its Ethernet Base MAC address. The controller validates this address against its AP address authentication list. If the address appears in the list, the AP is authenticated and gains access to the service control features on the controller.

If authentication fails (for example, this is a new AP), and the **Use the local authentication list** option is enabled, then the AP is added to the **Default Group** and flagged as requiring authentication. The AP must then be manually authenticated by a manager using the **Controlled APs >> Overview > Discovered APs** page. Once authenticated, the AP can be managed.

NOTE: APs remain visible in this list as long as they have been detected and authorized at least once. If an AP is no longer part of the network then a manager must manually remove it.

Building the AP authentication list

The controller can retrieve authentication list entries from several sources: a RADIUS account, a file, or using the set of locally configured APs. All entries are merged to create a combined list.

The controller retrieves authentication list entries when:

- The Authentication interval expires
- Authenticate Now is selected
- Save is selected
- Each time the controller starts up.

Each time the authentication list entries are retrieved, all connected APs are checked against it. If an AP MAC address is no longer listed, its connection is terminated.

NOTE: Although the same RADIUS account can be shared between this option and the **Public access > Attributes** page, HP recommends that a separate RADIUS account be created for each option.

General settings

Authentication interval

Specifies the interval at which the controller retrieves authentication list entries from the selected authentication sources. After the entries are retrieved all controlled APs are evaluated against the new list.

Authenticate Now

Causes the controller to retrieve authentication list entries from all selected sources.

Use file authentication list

When this option is selected, the controller retrieves authentication list entries from a file. This must be an ASCII file with one or more MAC addresses in it. Each address must be entered on a separate line. For example:

```
00:03:52:00:00:01
00:03:52:00:00:02
00:03:52:00:00:03
```

A label affixed to each AP indicates its Ethernet Base MAC Address. This is the address to specify in the authentication list.

File location

Specify the location of the file to use for authentication of APs using either HTTP or FTP. For example:

ftp://mydomain.com/auth_list

ftp://username:password@mydomain.com/auth_list

http://mydomain.com/auth_list

Use RADIUS authentication list

When this option is selected, the controller retrieves authentication list entries from a RADIUS server. List entries must be defined in the RADIUS account for the controller using the following Colubris-AVPair value string:

```
managed-ap=MAC_address
```

Where *MAC_address* is the Ethernet Base port MAC address of the controlled AP (which is printed on a sticker affixed to the AP case). Use colons to separate characters in the address.

For example:

```
00:20:E0:6B:4B:44
```

To define multiple addresses, specify additional entries as needed.

This attribute conforms to RADIUS RFC 2865. You may need to define this attribute on your RADIUS server if it is not already present as follows:

- SMI network management private enterprise code = 8744
- Vendor-specific attribute type number = 0
- Attribute type = string

RADIUS profile

When the **Authentication** source is **RADIUS**, this option specifies the name of the RADIUS profile to use. There is no default. To configure RADIUS profiles, select **Controller >> Authentication > RADIUS profiles**.

RADIUS username

When the **Authentication** source is **RADIUS**, specifies the RADIUS username assigned to the controller.

RADIUS password / Confirm RADIUS password

Specifies the password that corresponds with **RADIUS username**.

Use the local authentication list

When this option is selected, the controller creates authentication list entries based on the set of APs that are currently defined on the controller. For reference purposes, the table shows the **AP name**, **Serial number** and **MAC address** of all APs that are defined and will be included in the authentication list.

NOTE: When the local authentication list is enabled, the first time an AP tries to connect to the controller, a manager must manually accept the AP on the **Controlled APs >> Overview > Discovered APs** page by selecting the **Authorize** in the **Action** column for the AP. Otherwise, the AP will not be able to connect to the controller.

Configuring APs

This section explains how to configure APs using the Controlled APs menu in the **Network Tree**.

Overview

To make the configuration of multiple APs easier to manage, parameters settings are managed using a hierarchal structure, where the configuration settings at lower levels are inherited from those at higher levels. There are three levels to the hierarchy: base group, group, and AP. For example:

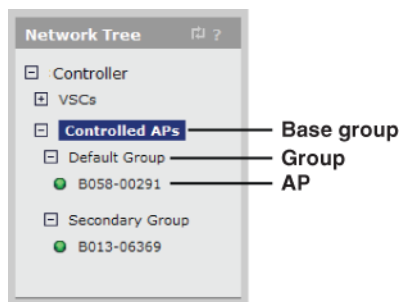

- Select the + symbol next to Controlled APs to expand the tree to see all groups.
- Select the + symbol next to each group to see its APs.

The levels are defined as follows:

- **Base group:** The base group is called **Controlled APs**. This name cannot be changed and you cannot create an additional base group. Settings made to the base group are inherited by groups and APs.
- **Group:** Group-level configuration enables you to define settings that are shared by APs with similar characteristics. For example, if you have several APs at a location that are all providing the same service, putting them in the same group makes them easier to manage. The **Default Group** is always present. All newly-discovered APs are initially placed into this group. You can create multiple groups.
- **APs:** AP-level configuration enables you to specify configuration settings for a particular AP that overrides corresponding group-level settings.

NOTE: Assignment of VSCs can only be done at the group level. This means that all APs in a group always have the same VSC settings. The exceptions to this are the HP 517 and MSM317 which allow VSCs to be bound to individual ports on its integrated switch. See the *HP 517 802.11ac Unified Walljack Configuration Guide* and the *MSM317 Access Device Installation and Configuration Guide*.

Inheritance

Configuration settings are inherited as follows:

- Settings made at the **Controlled APs** level are inherited by all groups.
- Settings made at the **Group** level are inherited by all the APs in a group.

To change inherited configuration settings you must first clear the **Inherited** checkbox. For example, the following image shows the **802.1X** page with the **Inherited** checkbox cleared, allowing all settings on this page to be customized.

AP: M1 | 802.1X Inherited

802.1X global settings ?

Supplicant time-out: seconds

Group key update

Key change interval:

Reauthentication

Period:

Terminate

Accounting start delay: seconds

Binding VSCs to groups

The controller defines a global pool of VSCs (see [“Working with VSCs” \(page 112\)](#)) that represents all services that are available. From this pool, specific VSCs can be *bound* to one or more groups, to define the features that will be offered to users throughout the wireless network.

NOTE: VSCs cannot be bound to individual APs or to the base group. VSC can only be bound to a group.

Any changes to a bound VSC affect all groups (and APs) to which the VSC is bound, making it easy to manage configuration changes network-wide.

A key setting when binding a VSC to a group is the **Egress network**. If you enable this option, it can alter where the APs send user traffic. See [“Traffic flow for wireless users” \(page 221\)](#) for detailed information on how the Egress network in a VSC binding can be affected by different configuration settings.

Group: Default Group | VSC binding ?

VSC Profile

VSC Profile:

Dual-radio behavior

On multiple radio products VSC is active on:

Egress network

Network profile:

Location-aware group

Group name:

NOTE: On an HP 517 or MSM317, VSCs can also be bound to a switch port. See the *HP 517 802.11ac Unified Walljack Configuration Guide* and the *MSM317 Access Device Installation and Configuration Guide*.

Synchronizing APs

After making configuration changes to an AP or a group, you must update all affected controlled APs with the new settings by synchronizing them. See [“Synchronizing APs” \(page 169\)](#).

Configuration strategy

There are two ways to approach AP configuration:

Discover APs and then configure groups

This strategy works as follows:

1. Deploy the APs in their default configuration on the network.
2. Allow the discovery process to find the APs and place them in the default group.
3. Create group definitions and then move the APs to the appropriate group.



TIP: Configure the default group to disable all radios. In this way, the default group becomes a staging area to hold newly added APs. Once discovered, the new AP can be moved to its appropriate group where its radio is activated.

Configure groups and then discover APs

This strategy works as follows:

1. Create group definitions.
2. Manually define each AP in the appropriate group.
3. Deploy the APs in their default configuration on the network.
4. Allow the discovery process to find the APs and place them in the pre-configured groups.

Working with groups

Adding a new group

To create a new group, do the following:

1. Select **Controlled APs >> Group management**.
2. Select **Add New Group**.
3. Specify the name of the new group and select **Save**.

Base Group: All | Group profile

Group settings ?

Name:

Cancel Save

Deleting a group

NOTE: You must remove all APs from a group before you delete it.

To delete a group, do the following:

1. Select **Controlled APs >> Group management**.
2. Select the name of the group you want to delete.
3. Select **Delete**.

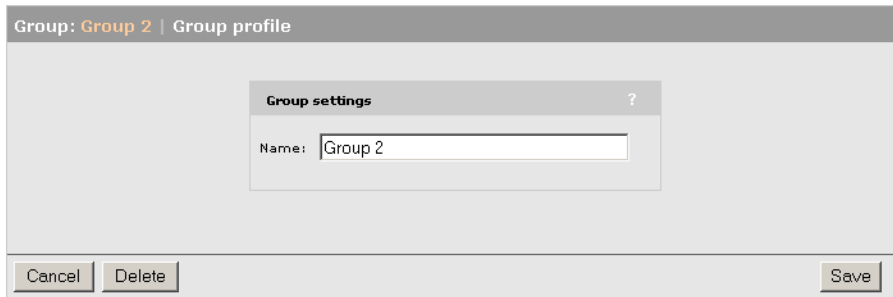

Binding a VSC to a group

This procedure applies to wireless users only. On the HP 517 or MSM317, VSC binding for wired users (connected to the switch ports) are done individually for each port.

To bind a VSC to a group, do the following:

1. Select the target group under **Controlled APs**.
2. In the right pane, select **VSC bindings**, then select **Add New Binding**.

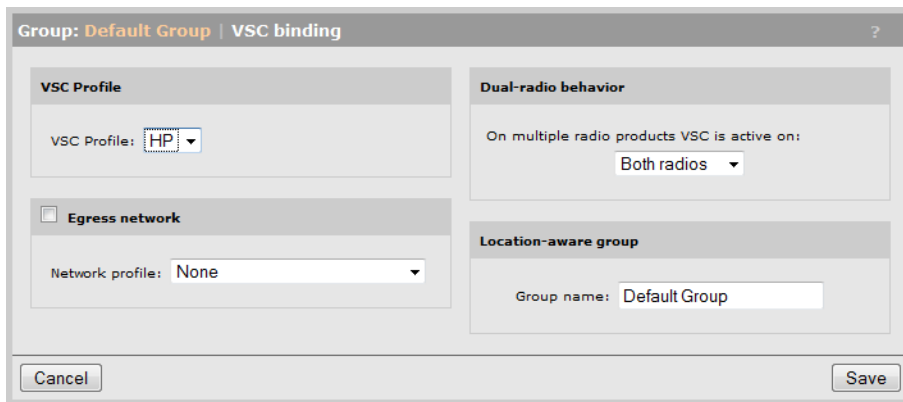

3. Select the **VSC profile** to which the group will be bound.
4. If you want to assign an egress mapping to the binding, select **Egress network** and select the required **Network profile**. The Egress network can be used to assign all traffic on the group to a specific VLAN. Other uses are also possible depending on the type of VSC to which the group is being bound. For more information, see ["Traffic flow for wireless users" \(page 221\)](#).
5. Select **Save**.

Working with APs

Manually adding a new AP

You can manually add APs to the controller before connecting the APs to the network. This is useful, for example, when you want to pre-designate the group into which an AP will be placed.

1. Select **Controlled APs >> Overview > Configured APs**.
2. Select **Add**.

- In the **Device** box, identify the new AP, specifying at a minimum, **Device Name**, **Ethernet BASE MAC** (printed on the label affixed to each AP), and **Group**.

Base Group: All | AP management

Device

Add new device:

Device Name:

Ethernet Base MAC:

Product:

Contact:

Location:

Group:

Select **Save**. The AP is added to the selected group in the **Network Tree** and will also be shown in the Configured APs list.

Summary

Controlled APs

Synchronized 5

Detected 5

Configured 5

Network Tree

- Controller
 - VSCs
 - HP
- Controlled APs
 - Default Group
 - B058-00466
 - CN9201X01T
 - K010-00981

Base Group: All | Configured APs

Number of displayed access points: 5

Filter APs by AP name

Move selected APs to group: -- Select a group --

<input type="checkbox"/>	Detected	AP name	Product	Serial number	MAC address	Group name	Creation mode	Already seen
<input type="checkbox"/>	Yes	B058-00466	MSM320	B058-00466	00:03:52:07:03:3A	Default Group	Discovered	Yes
<input type="checkbox"/>	Yes	CN9201X01T	MSM317	CN9201X01T	00:24:A8:4A:5A:38	Default Group	Discovered	Yes
<input type="checkbox"/>	Yes	K010-00981	MSM310	K010-00981	00:03:52:07:BC:56	Default Group	Discovered	Yes
<input type="checkbox"/>	Yes	SG0072SW98	MSM410	SG0072SW98	00:24:A8:88:50:6E	Default Group	Discovered	Yes
<input type="checkbox"/>	Yes	SG9142S069	MSM410	SG9142S069	00:24:A8:1A:38:A0	Default Group	Discovered	Yes

NOTE:

- When the AP is physically connected to the network, it will discover the controller and automatically be accepted into the selected group. Make sure you configure the correct MAC address, otherwise the AP will just be discovered as a new AP and will not be placed into the selected group.
- If an AP is created with the wrong product type it will go into the **Wrong product** state when discovered. (For example, if you specify MSM310 for an AP that is an MSM320.) To remedy this, select **Overview > Discovered APs** and select the **Accept Products** link in the **Action** column. (This action will override the pre-configured product setting by the information discovered from the actual physical AP.)

Editing AP settings

You can customize the settings for an AP as follows:

1. Select **Controlled APs** > [group] > [ap]. The AP management page opens.

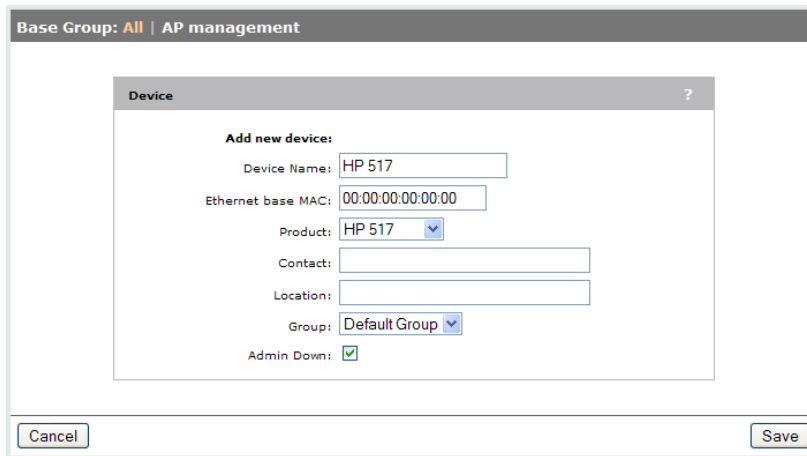

The screenshot shows a web interface for AP management. At the top, it says 'Base Group: All | AP management'. Below that is a 'Device' configuration window. The window has a title bar with a question mark. Inside, there's a section 'Add new device:' with the following fields: 'Device Name' (text input with 'HP 517'), 'Ethernet base MAC' (text input with '00:00:00:00:00:00'), 'Product' (dropdown menu with 'HP 517'), 'Contact' (text input), 'Location' (text input), 'Group' (dropdown menu with 'Default Group'), and 'Admin Down' (checkbox checked). At the bottom of the window are 'Cancel' and 'Save' buttons.

2. Configure settings as follows:

- **Device name:** Specify the name to assign to the AP. The name must not contain spaces.
- **Use AP name as DHCP client hostname:** Use this option to control how the DHCP hostname is assigned to the AP.
 - **Enabled:** The AP will use the Access point name as the hostname for all DHCP requests (using DHCP option 12). This is the name that will identify the AP in the hosts DHCP table.
 - **Disabled:** The AP will honor and use any hostname received from the DHCP server (using option 12) or default to using its serial number. When the controller is reset to factory defaults, this parameter is set to Disabled.
- **Ethernet base MAC:** Indicates the MAC address of the AP. This field cannot be changed.
- **Product:** Select the product type.
- **Contact:** Provide contact information for the AP. This field is optional and is for informational purposes only.
- **Location:** Specify the location where the AP is installed. This field is optional and is for informational purposes only. If the location name was defined using provisioning settings, it cannot be changed here, but must be changed on the **Provisioning > Location** page directly on the AP. Once an AP has established the secure management tunnel with a controller, the Provisioning pages on the AP are no longer accessible.
- **Group:** Select the group to which the AP will be added.
- **Admin Down:** (This parameter is only configurable when editing an AP that is inactive (not responding), or when adding a new AP.) Enable this option to flag an AP that is offline for a known reason (such as maintenance, relocation) to differentiate it from other APs that are offline for unknown reasons (network failure, power failure, or other issues that prevent them from communicating with the controller). APs flagged as Admin Down do not appear in the count of offline APs shown on the dashboard. When an AP comes back online, the Admin Down flag is automatically cleared.

3. Select **Save**.

Deleting an AP

NOTE: When the AP authentication feature is disabled, a deleted AP may automatically rediscover the controller if the AP is left connected to the network. Therefore, before deleting, disconnect the AP unless you want it to rediscover the controller.

To delete an AP:

1. Select **Controlled APs >> Overview > Configured APs**.
2. Select the AP name in the Overview table. This opens the AP management page. Select **Delete**. The AP is then deleted.

Moving an AP to a different group

NOTE: Moving an AP to a different group causes it to be restarted.

Using drag-and-drop

The easiest way to move an AP to a different group is to drag-and-drop it from the old group to the new group. Both groups must be visible in the **Network Tree** for this to work.

The move to the different group does not actually occur until the AP is synchronized as described in the next section, [“Synchronizing APs” \(page 169\)](#).

Using menus

1. In the **Network Tree** select the AP and then on the main menu, select **Device Management > AP management**.
2. Under Access point settings, select the desired **Group** and select **Save**.

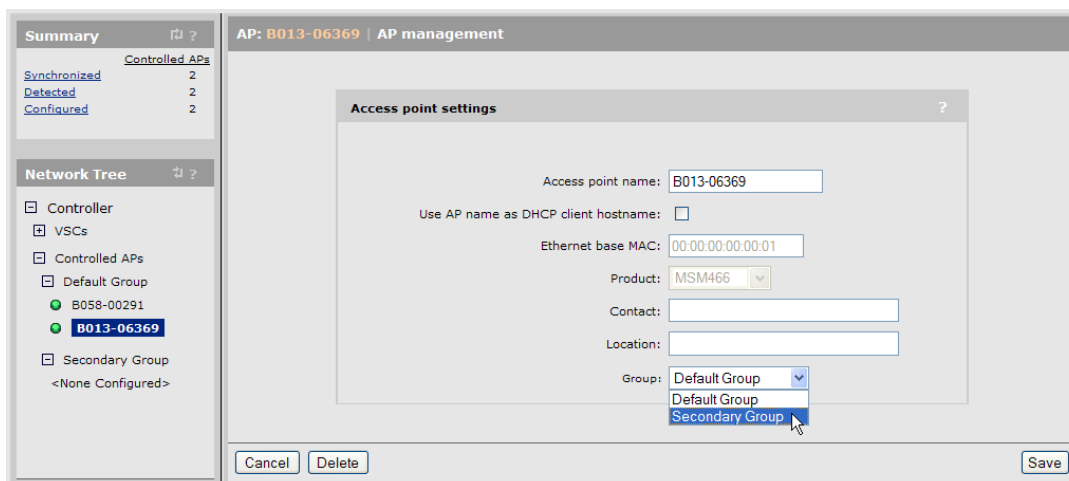

This puts the AP into the unsynchronized state (it will be displayed in orange). The move does not occur until the AP is synchronized as described in the next section.

Moving multiple APs between groups

To move one or more APs between groups, do the following:

1. Use the check boxes in the table to select one or more APs. Select the check box in the table header to select all the APs in the table.

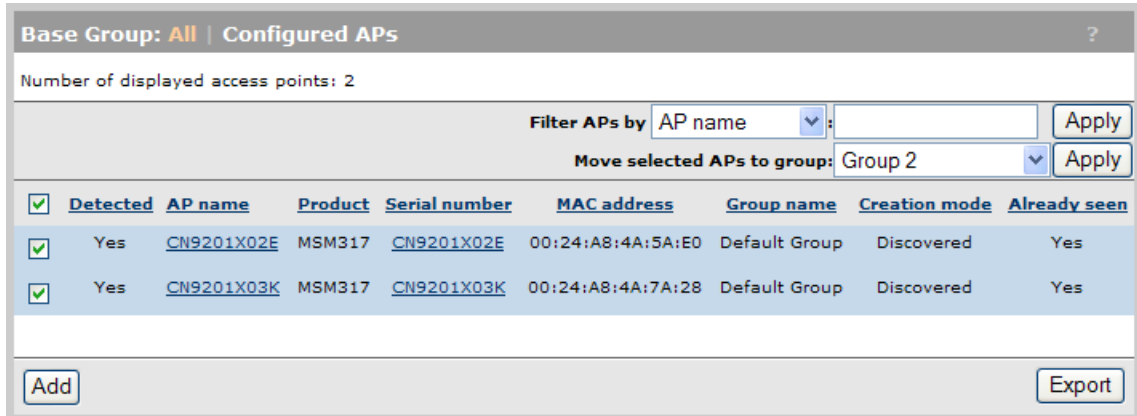

2. Select the group into which to move the APs from the list next to **Move selected APs to group**.
3. Select **Apply**.

Synchronizing APs

Depending on the type of configuration changes that are being synchronized, wireless users may be forced to reassociate or log in again.

After making configuration changes, you must synchronize the APs with the updated configuration as follows:

1. In the **Network Tree**, select the group that contains the APs, and then in the right pane, select **Discovered APs**. For example, **Secondary Group**.

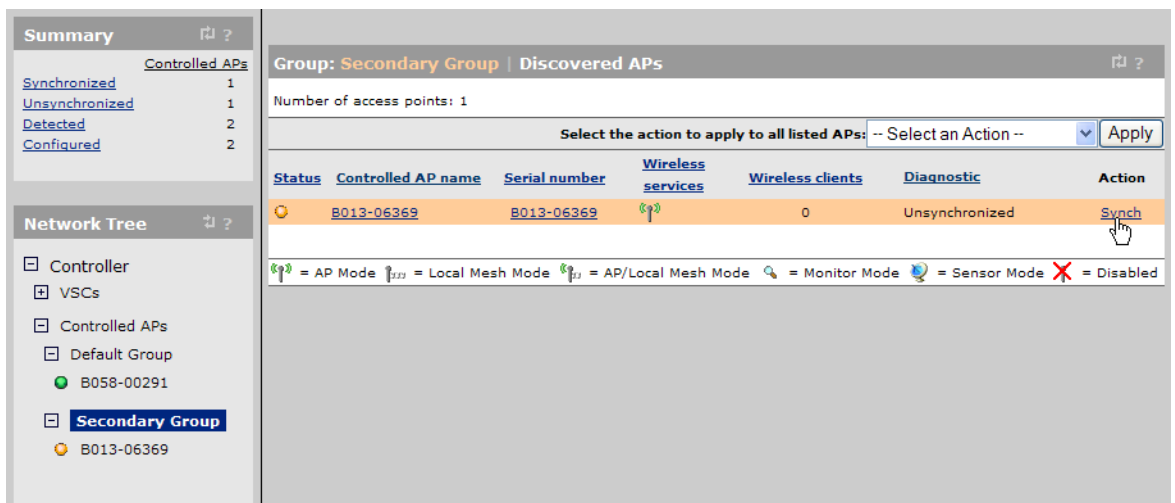

APs requiring synchronization are displayed with an orange background and show **Unsyncronized** in the **Diagnostic** column.

2. Select a **Synch** link in the **Action** column to synchronize a single AP.
Or, to synchronize all unsyncronized APs in the group, select **Synchronize Configuration** in the **Select the action to apply to all listed APs** list, and select **Apply**.
3. Monitor synchronization progress by watching the **Diagnostic** column. Messages such as **Resetting configuration** and **Restoring configuration** will appear during the synchronization process.

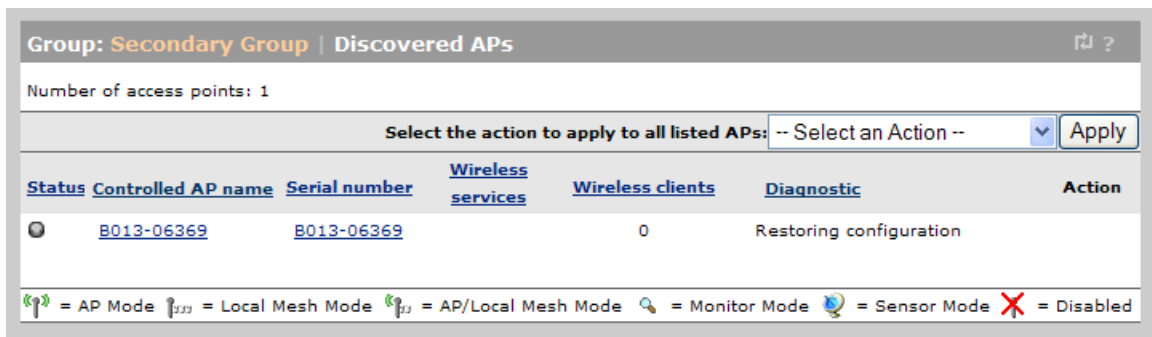

- As each synchronization completes, the **Status** light icon and background color of the synchronized AP changes to green. The status light icon next to the AP name under the pertinent group name in the **Network Tree** also changes to green. This indicates that the AP is fully operational and using its new configuration.

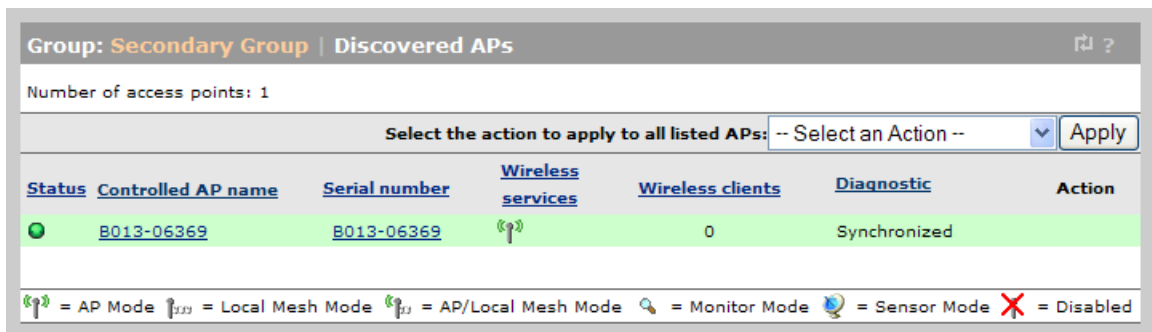

Assigning egress VLANs to a group

When you bind an AP to a VSC, you are able to assign an egress network to the binding. The egress network can be used to assign all the traffic on the group to a specific VLAN. Other uses are also possible depending on the type of VSC to which the group is being bound. For more information, see [“Traffic flow for wireless users”](#) (page 221).

Assigning country settings to a group

The country of operation, also known as the regulatory domain, determines the availability of certain wireless settings on an AP. The country of operation is configured at the group level.

To configure country settings, select either:

Controlled APs >> Configuration > Country

Controlled APs > [group] >> Configuration > Country

The country configuration for the Base group looks like this:

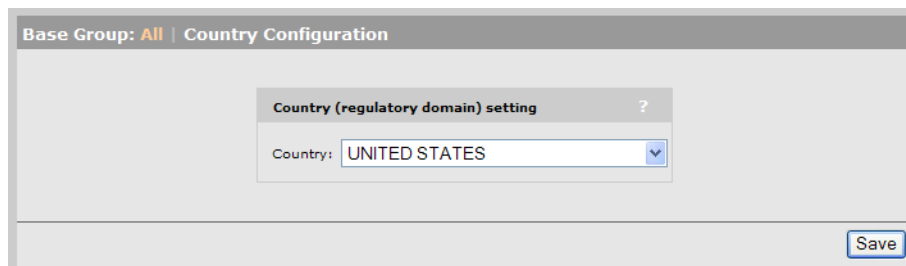

After changing the country setting, APs must be synchronized.

- △ **CAUTION:** Incorrectly setting the country may result in illegal operation and may cause harmful interference to other systems. Please consult with a professional installer who is trained in RF installation and knowledgeable about local regulations to ensure that the AP is operating in accordance with channel, power, indoor/outdoor restrictions and license requirements for the intended country. If you fail to heed this caution, you may be held liable for violating the local regulatory compliance

NOTE: In some regions, APs are delivered with a fixed country setting. If you place an AP with a fixed country setting into a group that has a different country configuration, the AP will fail to be synchronized. (The error **Incompatible settings** will be displayed on the **Controlled APs >> Overview > Discovered APs** page).

Provisioning APs

Provisioning is the means by which you can change the factory default IP addressing method and controller discovery settings on controlled APs.

Provisioning is generally not required when deploying controlled APs in simple network topologies. However, it is required as when:

- Controlled APs do not have layer 2 connectivity to a controller and where it is not possible to control the DNS or DHCP server configuration. See [“Discovery recommendations” \(page 151\)](#).
- Controlled APs need to be deployed with static IP addresses.
- Controlled APs use a local mesh to connect to the controller. See [“Provisioning local mesh links” \(page 391\)](#). This feature is not supported on the HP 517 or the MSM317.
- To accelerate the discovery process on networks with a large number of VLANs, or when many VLANs are connected to many controllers.
- When multiple controllers are available to an AP and you want to make sure an AP always connects to the same controller.

Provisioning methods

Provisioning can be done in two ways: provision settings using the controller or provision settings directly on APs.

Using the controller to provision APs

On the controller, provisioning can be done at the group or AP level for added flexibility. Provisioning via the controller enables you to quickly provision many APs at once.

In certain scenarios it may be practical to use one controller to provision APs, and then have the APs associate with another controller after being deployed. For example, provisioning could occur at the network operations center by connecting APs to the same subnet as a controller. Once provisioned, the APs can then be deployed in the field where they will discover a controller already in operation.

To enable a controller to send provisioned settings to controlled APs, you must first activate the **Enable provisioning of controlled APs** option on the **Controller >> Controlled APs > Provisioning** page.

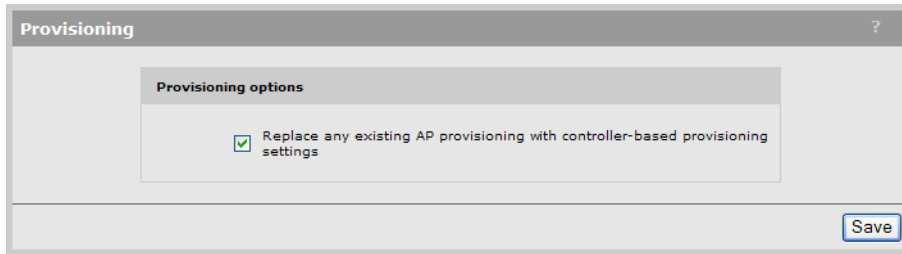

Define provisioning settings as described in [“Displaying the provisioning pages” \(page 172\)](#).

NOTE:

- Until this option is enabled, provisioned settings defined on the controller are not sent to any controlled APs.
- After an AP has been updated with provisioned settings, these settings do not become active until the AP is restarted, or a Remove and rediscover action is executed on the **Controlled APs >> Configured APs** page.

Directly provisioning an AP using its management tool

In its factory default state, the AP provides a provisioning menu with the same options that are available on the controller. Use this method when there is no local controller on which to perform the provisioning. See [“Displaying the provisioning pages” \(page 172\)](#).

NOTE: Once an AP has established the secure management tunnel with a controller, the provisioning menu on the AP is no longer accessible.

In both cases, the configuration settings that you have access to are the same. They are described in the following sections.

Displaying the provisioning pages

To display the provisioning pages, do the following:

On a controller

1. Select one of the following in the **Network Tree**:
 - Controlled APs
 - A group
 - An AP
2. In the right pane, select **Provisioning > Connectivity**.
3. Configure provisioning settings as described in the sections that follow.

On an AP in its factory-default state

1. Log in to its management tool.
2. Select **Provision** at the bottom of the home page.

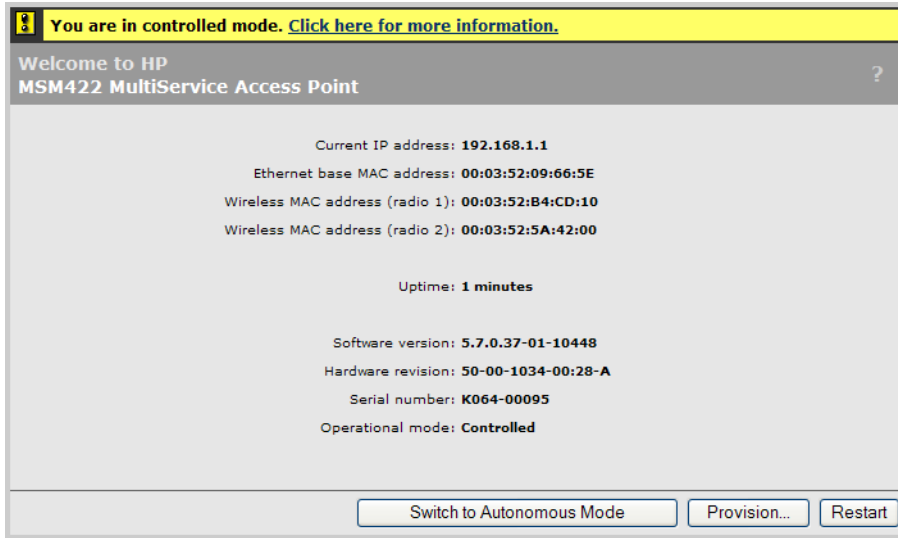

NOTE: The **Provision** button is only available if the AP is in its factory-default state, meaning it has not yet been provisioned and that the AP has never discovered a controller (since last factory default). To force an AP into its factory-default state, press and hold its reset button until the status lights blink three times.

3. Configure provisioning settings as described in the sections that follow.

Provisioning connectivity

Use the **Provisioning > Connectivity** page to provision connectivity settings for a controlled AP. The following page will appear on all APs except for the HP 517 and MSM317.

Enable provisioning here:

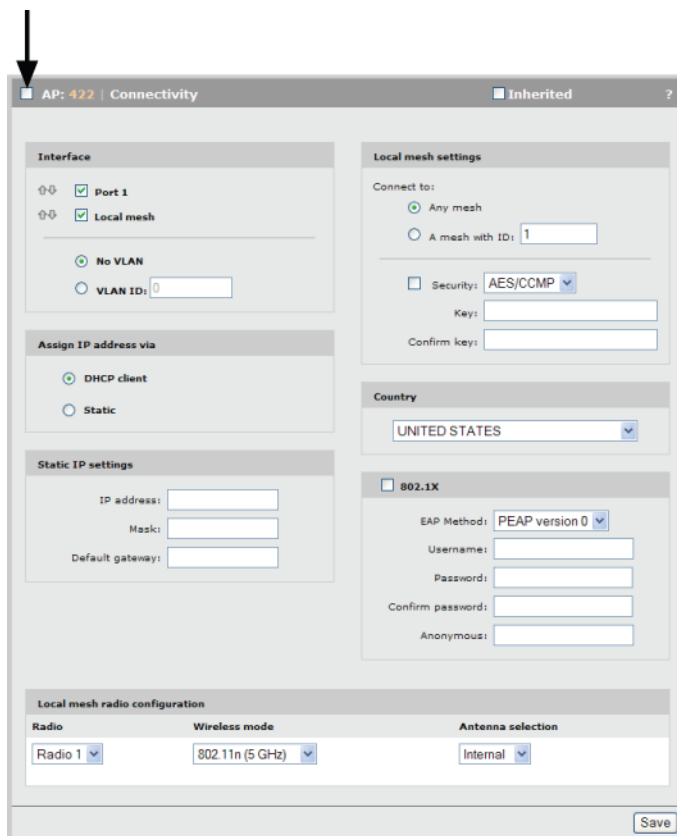

The following page will appear on the HP 517 and MSM317.
Enable provisioning here:

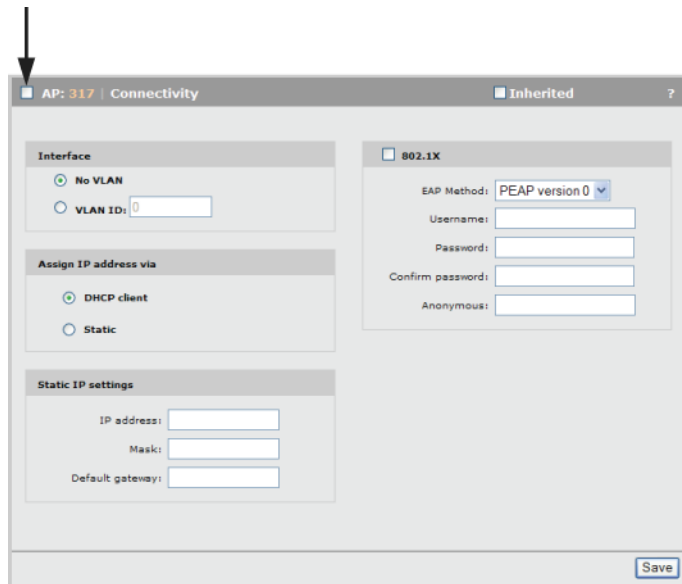

Settings

Interface

Select the interface you want to configure and then define its settings using the other options on this page. Set **VLAN ID** if applicable.

Assign IP address via

- **DHCP client:** Address is assigned using a DHCP server. Enable this option to have the interface act as a DHCP client. The AP sends DHCP requests on the specified VLAN. If no VLAN is specified, the request is sent untagged.
- **Static:** Select this option to manually assign an IP address to the interface.

Static IP settings

When you select **Static** for **Assign IP address via**, configure settings in this box.

- **IP address:** Specify the IP address you want to assign to the interface.
- **Address mask:** Specify the appropriate subnet mask for the IP address you specified.
- **Default gateway:** Specify the IP address of the default gateway.

Local mesh settings

For information on provisioning these settings, see [“Local mesh” \(page 384\)](#). (Not supported on the HP 517 or MSM317.)

Country

Select the country in which the AP is operating.

⚠ CAUTION:

- Selecting the wrong country may result in illegal operation and may cause harmful interference to other systems. Please consult with a professional installer who is trained in RF installation and knowledgeable about local regulations to ensure that the controller is operating in accordance with channel, power, indoor/outdoor restrictions and license requirements for the intended country.
- The Country option is not available on APs delivered with a fixed country setting.

802.1X

Enable this option when the AP is connected to a secured switch port that requires 802.1X authentication. Once the AP is authenticated, controller discovery proceeds as usual.

NOTE:

- If this option is enabled and the AP is connected to a unsecured switch port, 802.1X is ignored and discovery proceeds as usual.
 - The switch port is expected to be multi-homed, so that once authentication is successful, tagged and untagged traffic for any MAC addresses (including wireless clients) will be accepted by the switch.
-

In this type of environment, deployment can be a challenge, since the AP must already be configured with the correct 802.1X username and password before it is connected to the secured switch port. There are three solutions to this problem:

- During AP deployment, 802.1X is deactivated on the switch ports. The APs are connected and provisioned with the correct 802.1X settings by the controller. Once all APs are synchronized, 802.1X authentication can be enabled on the switch ports.
- Before being deployed, the APs are first connected to a controller via a non-secure switch. The APs are provisioned and synchronized with the correct 802.1X settings by the controller. Next, the APs are deployed to their final location.
- For small deployments, the administrator could connect each AP in turn to a computer and configure the appropriate 802.1X settings using the AP provisioning interface. This solution is time consuming and is not a realistic option for a large deployment.

EAP method

Select the extensible authentication protocol method to use:

- **PEAP version 0:** Authentication occurs using MS-CHAP V2.
- **PEAP version 1:** Authentication occurs using EAP-GTC.
 - **TTLS:** The Tunneled Transport Layer Security protocol requires that the switch first authenticate itself to the AP by sending a PKI certificate. The AP authenticates itself to the switch by supplying a username and password over the secure tunnel.

Username

Username that the AP will use inside the TLS tunnel.

Password / Confirm password

Password assigned to the AP.

Anonymous

Name used outside the TLS tunnel by all three EAP methods. If this field is blank, then the value specified for **Username** is used instead.

Provisioning discovery

Use the **Provisioning > Discovery** page to provision the method a controlled AP uses to discover a controller. Two options can be provisioned: DNS discovery or discovery via IP address. The following page shows Discovery using DNS provisioned.

Enable provisioning here:

Discover using DNS

The AP attempts to connect with a controller using the names in the order that they appear in this list.

To discover the controller on the network, the AP appends each name with the specified **Domain name**.

In the above example, the AP will search for controllers with the names:

- service-controller-1.mydomain.com
- service-controller-2.mydomain.com

If you define a name that contains a dot, then the domain name is not appended. For example, if the name is controller.yourdomain.com, no domain name is appended.

If the AP is operating as a DHCP client, the DHCP server will generally return a domain name when it assigns an IP address to the AP. If you leave the **Domain name** field on this page blank, then the DHCP domain name is appended to the specified names instead.

Discover using IP address

The AP attempts to connect with a controller using the IP addresses in the order that they appear in this list.

Discovery authentication

Authentication can be enabled during the discovery process to allow a controller and AP to validate each other prior to establishing a control channel. Authentication can be mutual, or can be preformed only by the controller or AP, depending on how you define the configuration.

- **Shared secret/Confirm shared secret:** Specify the shared secret that the AP will use when authenticating a controller or responding to an authentication request from a controller. For a control channel to be established, the secret you define here must match the one configured

for the controller under **Controller >> Management > Device discovery > Discovery authentication**.

- **Authenticate controllers before connecting:** Enable this option to have the AP authenticate a controller before establishing a control channel with it. If you do not enable this option, the controller may still authenticate the AP depending on the settings you make under **Controller >> Management > Device discovery > Discovery authentication**.

Provisioning summary

The following table defines the potential outcome for all provisioning scenarios.

Connectivity provisioned	Discovery provisioned	Result
No	No	Default behavior is used for connectivity and discovery. See “Discovery of controllers by controlled APs” (page 148) .
No	Yes	Discovery occurs using the provisioned methods on the following interfaces: <ul style="list-style-type: none"> • Last interface on which a controller was discovered. (Only applies to APs that have previously discovered a controller.) • Untagged on port 1 (Uplink port on the HP 517 or MSM317). • All detected VLANs (in sequence) on port 1 (Uplink port on the HP 517 or MSM317).
Yes	No	Discovery methods are used according to the provisioned connectivity settings. See “Discovery of controllers by controlled APs” (page 148) . Note: DHCP discovery is not executed if a static IP address is provisioned.
Yes	Yes	Discovery occurs using the provisioned methods over the provisioned connectivity. The provisioned discovery method is retried indefinitely if it fails, however other discovery methods are not attempted.

Provisioning example

The following example shows how to use the default group as a staging area, where APs are discovered and then provisioned before being moved into their actual production group.

1. Select **Controller >> Controlled APs > Provisioning**.
2. Select the **Enable provisioning of the controlled APs** option.
3. Select **Save**.
4. Select **Controller >> Controlled APs > Default group >> Configuration > Radios**.
5. Select each product in the table in turn, and disable its radio(s).
6. Select **Controller >> Controlled APs > Default group >> VSC bindings**.
7. Disable any active VSC bindings.
8. Connect all APs that need to be provisioned. Wait until they are discovered and assigned to the default group.
9. Select **Controller >> Controlled APs > Default group >> Provisioning > Connectivity**. Configure provisioning settings as required. For details, see [“Provisioning connectivity” \(page 173\)](#).
10. Select **Controller >> Controlled APs > Default group >> Provisioning > Discovery**. Configure provisioning settings as required. For details, see [“Provisioning discovery” \(page 175\)](#).
11. If required, select individual APs and define provisioning settings accordingly.
12. Synchronize the APs. For details, see [“Synchronizing APs” \(page 169\)](#). **The provisioned settings are not active at this point.**
13. Move the APs from the default group to their actual production group. For details, see [“Moving an AP to a different group” \(page 168\)](#). This will force a restart of the APs and initiate the provisioned settings.

AP survivability

APs that are configured with non-access-controlled VSCs using distributed deployment can continue providing services even when communication with the controller has been interrupted. This minimizes service interruptions caused by the AP needing to rediscover or resynchronize with the controller.

Distributed deployment means that the AP directly handles the service. It does not use the controller. For example:

- 802.1X authentication via a third-party RADIUS server
- MAC-based authentication via a third-party RADIUS server
- Traffic routing to the default gateway
- Use of an external DHCP server
- Use of an external DNS server

For AP survivability to work, the external servers must be reachable.

To configure this feature, select **Controlled APs >> Configuration > Services**. (This feature can also be configured at the Group and AP level.)



VSC services

When an AP loses contact with its controller, it automatically disables services on all access-controlled VSCs (except as noted earlier). When this option is enabled, the AP will also disable services on VSCs that are not access-controlled.

NOTE: This only affects services defined on the VSCs, and does not affect other functions, such as monitoring, scanning, and local mesh.

NOTE: Regardless of the setting of this option, when an AP loses contact with its controller it immediately initiates discovery to find a new controller. If it finds a new controller, its configuration will be updated with the settings on the new controller (which may change the setting of this parameter). If the AP re-establishes contact with its original controller, its configuration settings do not change.

No VSC services if controller is unreachable

- If this option is enabled, the AP disables services on all non-access-controlled VSCs after it loses contact with its controller. This means AP survivability is disabled.
- If this option is disabled, the AP continues to offer services on all non-access-controlled VSCs even after it loses contact with its controller. Default setting.

Switch ports

You can use this option to disable traffic on the switch ports when an HP 517 or MSM317 loses contact with its controller.

Disable switch ports if controller is unreachable

- If this option is enabled, the HP 517 or MSM317 disables services on all switch ports after it loses contact with its controller. This means AP survivability is disabled.
- If this option is disabled, the HP 517 or MSM317 continues to offer services on all switch ports even after it loses contact with its controller.
- This option is disabled by default.

AeroScout RTLS

Controllers and their controlled APs can be used to provide the Wi-Fi infrastructure for an AeroScout Real-Time Location Tracking (RTLS) system. APs, AeroScout Wi-Fi RFID tags, and the AeroScout MobileView software work together for the purpose of wirelessly tracking the location of valuable assets in real time. The controller forwards AeroScout tag information from controlled APs to a computer running the AeroScout Engine and MobileView software.

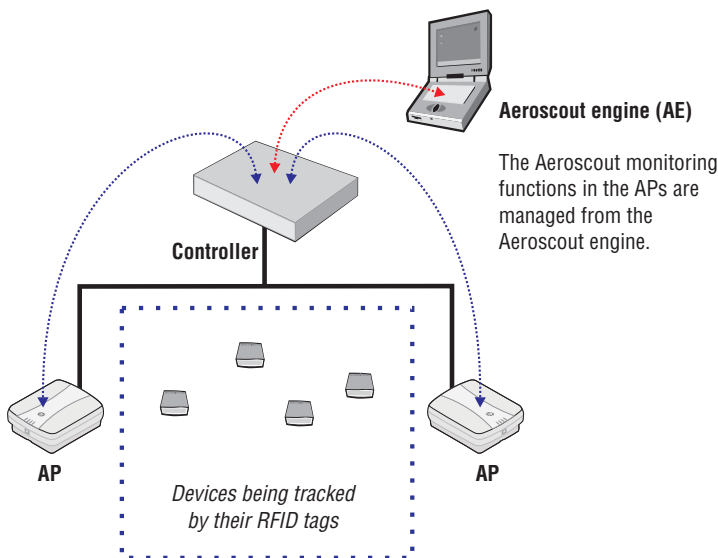

NOTE:

- HP does not sell or promote AeroScout products. Contact AeroScout for information on obtaining its MobileView software, Wi-Fi RFID tags, and associated hardware. Consult the AeroScout documentation for deployment information.
 - To work with MSM APs, the Wi-Fi RFID tags must be configured to send data in the WDS format (4 addresses). Channel allocation on the AP and tag must match as well.
 - AeroScout MobileView should be configured with the team IP address of the team that is managing the controlled AP.
-

To enable AeroScout support

AeroScout support is only available for controlled APs, with radios configured as **Access point only** or **Access point and Local mesh**, and operating in the 2.4 GHz band.

To configure the controller (and all its controlled APs) to work with AeroScout:

1. Select **Controller >> Controlled APs > RTLS**.
2. Select **Enable support for AeroScout tags and MU**.
3. Select **Save**.

Viewing status information

Basic AP and AeroScout tag status information is available by selecting **Controller > Controlled APs >> Overview > RTLS**. For example:

Base Group: All RTLS								
AP name	AP MAC address	Radio	Engine	Tag states	Mu states	Tag report	Tag adj msg	Mu report

All AeroScout management and monitoring is performed in the AeroScout software itself. Aeroscout documentation and AeroScout software must be used to operate and monitor the tags.

Values

AP name

Name of the AP on which HP RTLS is enabled.

AP MAC address

MAC address of the AP.

Radio

Radio on the AP to which the AeroScout tag is connected.

Engine

IP address and port to which the controller sends the tag and Mu reports generated by the AP.

Tag states

Shows two values: admin state / operational state

- Admin state: Indicates if the AeroScout engine requested that the AP process frames generated by AeroScout tags.
- Oper state: Indicates if the radio is actually listening for frames generated by AeroScout tags.

Mu states

Shows two values: admin state / operational state

- Admin state: Indicates if the AeroScout engine requested that the AP process Mu (mobile unit) information.
- Oper state: Indicates if the radio is actually listening for Mu (mobile unit) information.

Tag report

Number of tag reports sent to the Aeroscout engine.

Tag adj msg

Number of tag messages that were dropped because they were received on the wrong channel.

Mu report

Number of Mu reports sent to the Aeroscout engine.

Software retrieval/update

Software management of controlled APs is automatically performed by the controller after the AP is discovered (see [“Key controlled-mode events” \(page 146\)](#)).

If the software version on the AP does not match the version installed on the controller, new software is installed on the AP by the controller.

For information on how to update the controller software see [“Software updates” \(page 539\)](#).

Monitoring

The controller provides a series of pages that present monitoring and status information for controlled APs. You can view these pages for all controlled APs, for all APs in a group, or for just a specific AP. All options appear on the **Overview** menu, which can be reached by selecting:

- **Controlled APs >> Overview.**
- **Controlled APs > [group] >> Overview.**
- **Controlled APs > [group] > [AP] >> Overview.**

See the online help for details about the information provided on these status pages.

9 Radio Resource Management

The radio resource management (RRM) feature provides effective auto-channel and auto-power mechanisms that enable administrators to optimize their wireless RF environment.

RRM can create a system-wide channel/power plan that maximizes capacity, coverage, and usage across all the AP radios in a network. Once this RF plan is in place, RRM can continuously monitor the RF environment to detect issues that impact performance and automatically make adjustments to mitigate any problems.

RRM requires a detailed system-wide understanding of the radio environment. To collect this information, each AP scans its local radio environment and sends the data to the controller, which then aggregates the information to provide a complete picture of the radio environment. The information is gathered continuously as a background activity, so that the controller always has a reasonably up-to-date view of the RF environment throughout the network.

Using this information, the controller can periodically (or manually under administrator control) run an analysis to create a channel/power plan. The administrator can choose to have RRM automatically apply the new channel/power plan, or review the proposed changes and then apply them manually. The power/channel plan algorithm then transitions the network from the old plan to the new plan with minimal disruption of service, coverage, and performance.

Monitoring active (in-use) channel(s) by an AP is straightforward. But, to support RRM, the AP must also monitor the alternate channels. To accomplish this, APs devote a small percentage of time to off-channel scanning (typically less than 1%). (Off-channel scanning for RRM purposes is integrated with IDS scanning.)

The core functionality of RRM is system-wide control of auto-channel and auto-power settings for all controlled APs. The algorithm runs centrally on the controller (or team manager) and collects information from all controlled APs. This information includes the current radio operating configuration (channel and power), a list of neighbor radios heard by each radio (SSID, BSSID, average RSSI of beacons, etc.), and channel quality metrics for all potential channels of each radio.

Supported products

RRM is supported on the following products:

- HP MSM720
- HP MSM760
- HP MSM765 zl
- HP MSM775 zl
- HP MSM410 (Severe interference detection/mitigation, including spectral analysis, is not supported.)
- HP 425
- HP MSM430
- HP MSM460
- HP MSM466/466-R
- HP 517 (Severe interference detection/mitigation, including spectral analysis, is not supported.)

All RRM features will work on controller teams.

On older APs (MSM310, MSM32x, MSM33x, MSM317, and the MSM422), auto-channel and auto-power are performed on the AP (in a non-system-wide fashion). The RRM system-wide auto-channel/power algorithms treat these APs as *external* APs when calculating the channel/power plan.

Mitigation of poor RF performance

RRM provides several features that help to mitigate wireless performance issues.

AP/radio down detection and mitigation

Each AP in the network maintains a list of neighboring APs, with information gathered from the beacons it receives. These beacons may be received on the current operating channel and also by scanning non-operating channels in both frequency bands (2.4 GHz or 5 GHz).

Each AP monitors the state of its neighbors to detect radio-down transitions. An AP only monitors nearby neighbors, those whose beacons are received reliably and with a high RSSI (received signal strength indicator).

When an AP stops receiving beacons from a nearby neighbor for a period of time, it informs the controller. Subsequently, if the AP starts receiving beacons from that neighbor, it will inform the controller that the neighbor radio is back.

The controller maintains a list of all neighbors for RRM purposes. Based on the radio-down indications it receives, the controller analyzes the situation to determine if the radio-down (or AP-down) condition is valid. Basically, the controller waits for indications from several neighboring APs before deciding that an AP radio has failed. It then sends messages to neighbors of the failed AP to mitigate the problem. Actions that might be taken include:

- Increase the power of neighbor APs (if any are operating at less than maximum power) to cover the area that was serviced by the failed radio.
- Accept new client stations with below-normal RSSI so clients that were serviced by the failed radio can reconnect.

The controller reports the radio-down condition as an alarm. Additional diagnostic information is also logged.

This feature also detects channel changes by neighboring radios, and generates an event for each occurrence. In these cases, no mitigation is needed because the radio is still operating.

Severe interference detection and mitigation

For RRM purposes, each AP radio maintains channel-quality information for all potential operating channels. The information for the current operating channel is derived using performance statistics (packet retry rates, error rates, per-client data-rates), beacons received from in-channel neighbor APs, spectrum analysis samples, etc.

When an AP detects a severe degradation in the channel quality of the current operating channel on a radio (that persists for tens of seconds), the AP informs the controller that it is experiencing severe channel interference and wants to initiate a channel change. Before doing this, the AP does an intensive spectrum analysis scan to identify the type of interference. This information is included in the report to the controller.

The controller responds to the AP and provides it with a prioritized list of alternative channels that are optimal from a system-wide perspective. The AP does a quick check of each channel in priority order to verify that interference is not present. Assuming a new channel is usable, the AP initiates a channel switch to the alternate channel. The AP then informs the controller that it has switched channels.

After switching to an alternative channel, the AP continues to monitor the channel quality of the non-operating channels. Eventually, it is expected that the interference will go away. (Most interference sources are temporary.) At this point the AP informs the controller that the original channel is clear. The controller then decides whether the AP should switch back to the original channel or continue operating on the alternate channel. To configure this option, see [“Severe interference detection/mitigation”](#) (page 97).

Spectrum analysis

(Only supported on the HP 425, MSM430, MSM460, and MSM466/466-R.)

RRM gathers spectrum analysis samples to derive a measure of the non-802.11 RF noise for each scanned channel. This is used for channel-planning purposes and as one indicator of severe RF interference.

RRM also uses an intensive-sampling mode of operation to classify an RF interference source when a channel-switch is needed due to significant RF interference.

Defining RRM scanning settings for a radio

Radio scanning settings can be defined globally for all APs in the system (base group), or at the group level. The following procedure illustrates configuration of the base group. Configuration of settings at the group level is identical.

To customize scanning settings for an AP, select **Controlled APs >> Radio management** and then select an AP in the list.

Scanning is controlled by the options selected for **Operating Mode**, **Channel**, **Transmit power control**, and **Neighborhood scanning**. Scanning services are used by both RRM and IDS.

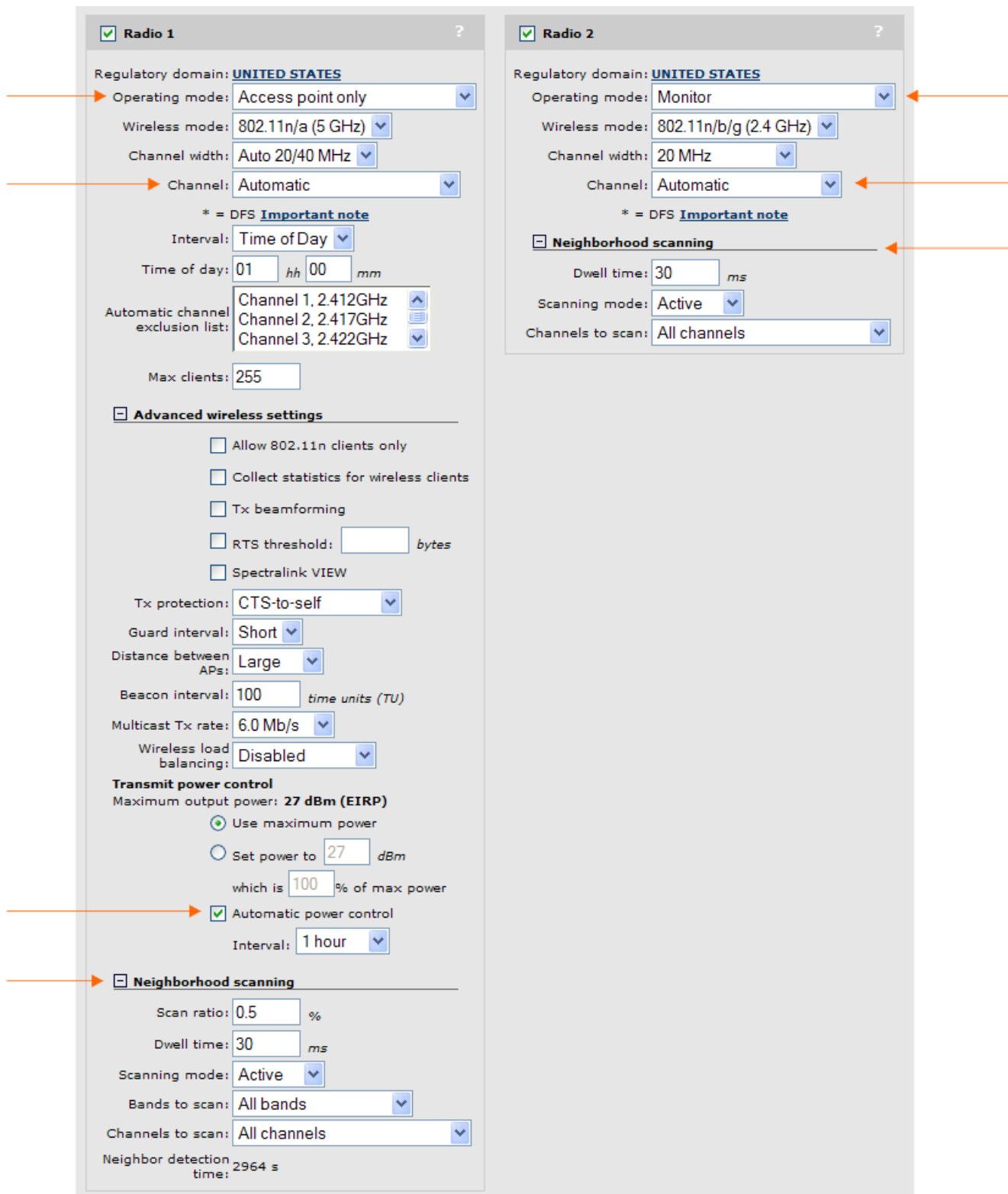

The scanning mode that an AP uses is determined by the setting of the **Operating mode** parameter. Choices are as follows:

- **Access point only:** In these modes, scanning operates in the background. The radio periodically switches away from the operating channel for a short period of time to listen for activity on

non-operating channels. The amount of time dedicated for scanning is defined by the settings you define for **Neighborhood scanning**.

- **Monitor:** In this mode, the radio only performs scanning, wireless services are not available.
- **Local mesh only** and **Access point and Local mesh:** Scanning is not supported in these modes.

To support the system-wide auto-channel feature, set **Channel** to **Automatic**.

To support the system-wide auto-power feature, enable **Automatic power control** under **Transmit power control**.

Neighborhood scanning settings

(Not configurable when **Operating mode** is set to **Access point and Local mesh** or **Local mesh only**.)

These settings let you fine-tune the scanning operation.

Scan ratio

(Not configurable when **Operating mode** is set to **Monitor**.)

The percentage of time the radio will spend scanning channels other than the operating channel.

Dwell time

The amount of time (in milliseconds) that a radio remains on a channel while performing channel scanning. The default value is 30 milliseconds. On the HP 517, the minimum value and default setting is 32 milliseconds.

- When **Operating mode** is set to **Access point only**, specify a value between 20 and 32 milliseconds. (Use a value of 30 milliseconds on the MSM410.)
- When **Operating mode** is set to **Monitor**, specify a value between 20 and 1000 milliseconds.

Scanning mode

- **Passive:** The AP listens to the channel to detect wireless traffic, but does not transmit any probes. The AP will receive beacon frames and probe response frames, and uses them to identify neighbors. (When IDS is enabled, other frames are also received and sent to the IDS system for analysis.) The key point is that no frames are transmitted. This is important for DFS channels and regulatory-prohibited channels.
- **Active:** The AP uses probe request frames to speed up neighbor detection. Active scanning only occurs on channels permitted by the regulatory domain. Transmission of probes is not allowed on DFS channels, so no probes are sent on DFS channels even when this option is selected.

Bands to scan

(Not configurable in **Monitor mode**. The **All bands** option is automatically used.)

- **All bands:** Scan both 802.11 bands (2.4 GHz and 5 GHz).
- **Operating band only:** Scan only the band in which the radio is currently operating.

Recommended settings for single radio APs:

- With IDS disabled, select **Operating band only**.
- With IDS enabled, select **All bands**.

Recommended settings for dual radio APs:

- With IDS disabled, configure both radios for **Operating band only**.
- With IDS enabled, configure the 2.4 GHz radio for **Operating band only** (with a small scan ratio), and configure the 5 GHz radio for **All bands** (with a larger scan ratio). The 2.4 GHz

band is probably much busier than the 5 GHz band, so IDS scanning using the 5 GHz radio has a reduced performance impact.

Channels to scan

- **All channels:** Scan all channels supported by the current operating mode.
- **Regulatory channels only:** Scan only channels supported by the current regulatory domain (country).
- **Non-excluded channels only:** When enabled, the AP will not scan any channels in the **Automatic channel exclusion list**.

Neighbor detection time

Estimated time in seconds to detect a neighbor.

Viewing the RRM radio map

The RRM radio map displays all radios that are detected within the operating area of all controlled APs. Select **Controlled APs >> Radio management > Radios map** to see the map. For example:

Base Group: All | Radio map
Number of displayed radios: 242

Show 20 entries

Filter entries by: MAC address

MAC address	AP name	Mode	Last detected	Band	Channel	Power	SSIDs	Neighbors	Utilization	IDS	Interference
00:24:A8:8A:51:70	SG9142C02P	C	N/A	2.4 GHz	1	20	1	72	0	Authorized	●
98:4B:E1:1E:D1:C0	CN14D32006	C	N/A	5 GHz	153	26	1	8	0	Authorized	●
98:4B:E1:1E:D1:D0	CN14D32006	C	N/A	2.4 GHz	11	20	1	86	0	Authorized	●
98:4B:E1:21:21:20	CN14DLL02L	C	N/A	5 GHz	161	20	1	196	0	Authorized	●
98:4B:E1:21:21:30	CN14DLL02L	C	N/A	2.4 GHz	11	20	1	209	0	Authorized	●
00:03:52:08:00:00	N/A	U	2012-11-05 15:38:14	2.4 GHz	4	N/A	1	N/A	N/A	External	●
00:03:52:5A:A8:31	N/A	U	2012-11-05 15:08:47	2.4 GHz	6	N/A	1	N/A	N/A	External	●
00:03:52:80:C3:B0	N/A	U	2012-11-05 15:38:02	2.4 GHz	2	N/A	1	N/A	N/A	External	●
00:03:52:80:C8:71	N/A	U	2012-11-05 15:32:10	2.4 GHz	8	N/A	1	N/A	N/A	External	●
00:03:52:80:C8:72	N/A	U	2012-11-05 15:32:10	2.4 GHz	8	N/A	1	N/A	N/A	External	●
00:03:52:80:C8:73	N/A	U	2012-11-05 15:32:10	2.4 GHz	8	N/A	1	N/A	N/A	External	●
00:03:52:8E:46:A1	N/A	U	2012-11-05 15:40:03	5 GHz	153	N/A	1	N/A	N/A	External	●
00:03:52:8E:46:A2	N/A	U	2012-11-05 15:40:03	5 GHz	153	N/A	1	N/A	N/A	External	●
00:03:52:8E:46:A3	N/A	U	2012-11-05 15:40:03	5 GHz	153	N/A	1	N/A	N/A	External	●
00:03:52:8E:4B:60	N/A	U	2012-11-05 15:32:35	5 GHz	153	N/A	1	N/A	N/A	External	●

First Previous 1 2 3 4 5 Next Last

Last updated: 2012-11-05 15:42:33 Refresh

Filter all entries by

To narrow down the list of radios in the table, select a category and enter text on which to filter the radio list. Click **Apply** to activate the filter.

Table

- **MAC address:** MAC address of the radio.
- **AP Name:** Name of the AP or identifier, if any.
- **Mode:**
 - **C:** Controlled by this controller.
 - **D:** Radio is disabled.

- **L:** Legacy radio. Any radio that does not support RRM. (For example, the MSM3xx series.)
- **M:** Monitor mode. Radio is operating in monitor mode.
- **S:** Sensor mode. Radio is operating in sensor mode.
- **U:** Uncontrolled. An radio that is not controlled by this controller. In IDS it is known as an *External* or *Rogue* radio.
- **Last detected:** Date and time when the radio was last known to be active in the RF environment. (The date and time that a beacon from the radio was received by a controlled AP.)
- **Band:** Frequency band in which the radio is operating: 2.4 GHz band (for 802.11b/g/n) or 5 GHz band (for 802.11a/n, 802.11ac/n).
- **Channel:** Main channel on which the radio is operating. Hover your mouse pointer over the yellow triangle to get more information if there is a difference between the planned and operating channel.
- **Power:** Radio's transmission power. Hover your mouse pointer over the yellow triangle to determine the reason for the difference between planned and operating power.
- **SSIDs:** Count of SSIDs. Hover your mouse pointer over the count to see the list of SSID names.
- **Neighbors:** Number of radios seen as neighbors by this radio. If the value is not available, "N/A" is displayed. Two radios are considered to be neighbors if either radio can detect frames (beacon frames, typically) transmitted by the other. Normally, RF propagation between two radios is symmetric. However, this may not be the case if the two radios use different transmit power, or if a noise source close to one radio is interfering with signals from the other, especially when signal levels are weak. All neighbors are listed, even those at very low power.
- **Utilization:** The average number of clients that were associated with the radio during the last hour.
- **IDS:** IDS classification. To change a classification manually, select **Controlled APs >> Security > Neighborhood**.
 - **Authorized:** A controlled radio, or a radio marked as authorized by the administrator. These radios are expected to be active and connected to the network.
 - **External:** A radio operating in the area, but not marked as authorized by the administrator. For example, an radio on an AP belonging to another nearby company. .
 - **Rogue:** An AP that is connected to the network, but is not supposed to be there.
 - **Unclassified:** Temporary state. The radio has been detected and is in the process of being classified as either External or Rogue.
- **Interference**
 - **Green:** No interference.
 - **Grey:** Unknown.
 - **Yellow:** Interference detected. A neighbor of the AP has switched channels because of interference and there is a risk of performance impact.
 - **Red:** Interference was detected that impacted performance. The AP has switched channels.

Configuring and conducting RRM analysis

Select **Controlled APs >> Radio management > RRM** to configure and manage RRM analysis options.

- ⓘ **IMPORTANT:** RRM analysis cannot be run until the network is complete and stable. This means that all of the following conditions must be true:
- All controlled APs are synchronized with the configuration settings on the controller.
 - The number of controlled radios in the network has not changed during the last 30 minutes.
 - No controlled radio in the network has had its configuration changed and synchronized during the last 30 minutes.
 - The majority (at least 99%) of the controlled APs in the network are operational and communicating with the controller.
 - All controlled radios have been operational for the **Neighbor detection time** (shown on the Radio configuration page for each radio).
 - The controller has received RF environment information from all controlled APs.
 - If operating in teaming mode, all team members are operational and synchronized with the team manager.

Configuring RRM options

Before you can run an analysis, the first thing you need to do is define RRM configuration settings at the bottom of the page.

The screenshot shows the 'RRM configuration' page for a 'Base Group: All'. It features two main sections: 'Configuration' and 'Schedule automatic analysis'. The 'Configuration' section has four checked options: 'Auto-channel (system-wide)', 'Auto-power (system-wide)', 'Radio-down mitigation (system-wide)', and 'AP load balancing (system-wide)'. The 'Schedule automatic analysis' section has a checked checkbox, followed by 'Run analysis:' with three dropdown menus set to 'Weekly', 'Monday', and '2 AM'. There is also an unchecked checkbox for 'Automatically apply new analysis'. A 'Save' button is located at the bottom right.

Configuration

Select the RRM feature that you want to activate. Auto-channel is enabled by default.

Auto-channel (system-wide)

The system-wide auto-channel feature will only adjust the operating channel on controlled AP radios that are configured to use automatic channel selection (i.e., Channel set to Automatic on the Radio configuration page).

Auto-channel is run before auto-power if both features are enabled.

The goal of this feature is to maximize the total potential wireless data capacity for the network as a whole, while allowing each AP/radio to get its fair-share of available channel time. Auto-channel optimizes the channel assignment for all radios in the network that are operating on a non-fixed channel. Radios on non-controlled APs, as well as those on controlled APs that do not have their **Channel** set to **Automatic** on the Radio configuration page, are considered fixed channel (unchangeable) and are not optimized by auto-channel.

How it works

In the 5 GHz band, auto-channel attempts to choose the best operating channel based on achieving the following goals:

- Minimize co-channel operation by avoiding the use of the same channel as on neighboring radios.
- Minimize adjacent channel interference on neighboring radios. For example, channels 36 and 40 are adjacent channels. There will be interference if radios using these channels are near each other.
- Operate at the highest transmit power. In different regulatory domains (countries), the allowed transmit power may vary for different channels. (For example, in North America, the limits for channels 36 and 40 are lower than for channel 100.)
- Have minimal non-802.11 RF noise.
- Use a non-DFS channel, if it provides the same benefits as using a DFS channel.
- Try to use all available channels in the 5 GHz band equally across all radios managed by the system as a whole.

In addition, there are considerations for 20/40 MHz channel widths:

- Choose channels consistent with the channel-width configured on a radio, and account for the fact that external APs may also be operating in 20 or 40 MHz widths.
- Choose channels to align the primary-channels. (E.g., channels 36+ and 40- are 40 MHz-wide channels which use the same RF frequencies, but differ in their primary channel.)

In the 2.4 GHz band:

- Auto-channel prefers the standard non-overlapping channels (1, 6, 11 in the US and 1, 7, 13 in Europe). If channel 13 is excluded (in the exclusion list) in a regulatory domain which normally allows it, then the US channel set (1, 6, 11) is used. This was done to support deployments in Europe that service US visitors. US devices generally cannot operate on channel 13. (If all but four channels are excluded, then auto-channel will switch to a four-channel plan. For example, if all channels except 1, 5, 9, and 13 are excluded, then auto-channel will only use those four channels.)
- Auto-channel prefers sharing a channel rather than choosing a channel that (potentially) overlaps two other in-use channels.

Auto-power (system-wide)

The system-wide auto-power feature will only adjust the power on controlled AP radios that have the **Automatic power control** option enabled on the Radio configuration page.

Auto-power can only be enabled if Auto-channel is enabled. The auto-power algorithm is run after auto-channel.

The goal of auto-power is similar to auto-channel (maximize the wireless capacity and fair-share access), but auto-power also needs to minimize the possibility of coverage holes. The auto-power algorithm only considers non-fixed-power radios. Radios on non-controlled APs, as well as those on controlled APs that do not have the Automatic power control option enabled on the Radio configuration page, are considered fixed power (unchangeable) and are not optimized by auto-power.

Lowering the power on a radio reduces the area it covers and can leave a hole in the wireless network if a radio does not have many neighbors. Therefore, auto-power will only reduce the power to a radio if it has several neighbors providing overlapping coverage. Expect power adjustments for radios with four or more neighbors operating nearby.

The auto-power scan will also detect cases where radios are so close together that even with power adjustment, co-channel interference cannot be eliminated. In these cases, auto-power will only adjust the power of these two radios if the interference with more distant co-channel neighbors

can be reduced. Otherwise, it is better to accept the fact that the radios must share the channel, and to operate the radios at full power.

Radio-down mitigation (system-wide)

When this option is enabled, the controller will attempt to mitigate wireless coverage issues created by inoperable radios.

Each AP in the network maintains a list of neighboring AP radios, with information gathered from the beacons it receives. These beacons may be received on the current operating channel and also by scanning non-operating channels in both the 2.4 GHz or 5 GHz frequency bands. (Channel scanning is configurable on the Radio page. The AP will track information only for the channels that are being scanned.)

Each AP monitors the state of its neighbors to detect radio-down transitions. An AP only monitors nearby neighbors, those whose beacons are received reliably and with a high RSSI (received signal strength indicator).

When an AP stops receiving beacons from a nearby neighbor for a period of time, it informs the controller. Subsequently, if the AP starts receiving beacons from that neighbor, it will inform the controller that the neighbor radio is back.

The controller maintains a list of all neighbors. Based on the radio-down indications it receives, the controller analyzes the situation to determine if the radio-down (or AP-down) condition is valid. Basically, the controller waits for indications from several neighboring APs before deciding that an AP radio has failed. It then sends messages to neighbors of the failed AP to mitigate the problem. Actions that might be taken include:

- Increase the power of neighbor radios (if any are operating at less than maximum power) to cover the area that was serviced by the failed radio.
- Accept new client stations with below-normal RSSI so clients that were serviced by the failed radio can reconnect.

The controller reports the radio-down condition as an alarm. Additional diagnostic information is also logged.

This feature also detects channel changes by neighboring radios, and generates an event for each occurrence. In these cases, no mitigation is needed because the radio is still operating.

AP load balancing (system-wide)

(Not supported on the HP 517.)

Use these options to set up RRM to periodically perform an analysis and apply the results to the network automatically if desired. If the automatic option is not enabled, the administrator will have to apply the new baseline manually.

The AP load balancing feature provides administrators with a way to spread the wireless load between radios. The goal of load balancing is to have the wireless client count for each radio match the average wireless client count across all radios on APs operating nearby.

When this option is enabled, the controller tracks the number of associated wireless clients on each controlled AP/radio. Using the network map, the controller identifies the neighbors of each radio, and computes the average number of clients per radio for those neighbors. The averages are computed separately for each band (2.4 GHz and 5 GHz) and are communicated to each AP periodically.

The load balancing algorithm runs individually on each AP. It is activated only when more than fifteen clients are associated with an AP. For each radio, the AP determines which load balancing action to take:

- **Operate normally:** The radio client load is comparable to its neighbors.
- **Discourage new clients:** The radio is overloaded compared to its neighbors. (Only done if the number of clients on a radio differs from the average on all radios by more than five.)
- **Encourage new clients:** The radio is under-loaded compared to its neighbors.

The following strategies are used to discourage new clients:

- The radio gradually decreases the transmit power for beacon and probe response frames by a total of 6 dB over a 30 second period. The transmit power for all other frame types is left unchanged.
- The radio delays probe response frames to encourage clients to choose another radio that responds faster.
- The radio rejects the first association request from a new client with a -17 error code: Association denied because the radio is unable to handle additional associated STAs.

Schedule automatic analysis

Use these options to set up RRM to periodically perform an analysis and apply the results to the network automatically if desired. If the automatic option is not enabled, the administrator will have to apply the new baseline manually.

Running an analysis manually

Use the **Analysis** box to manually run an RRM analysis and also to view the results of the last analysis that was run, or to view information about an analysis that is in progress.

The screenshot shows the 'RRM analysis' interface. At the top, it says 'Base Group: All | RRM analysis'. Below this is the 'Analysis' section. On the left, there is a table titled 'Current network status' with two columns: 'Description' and 'Radios'. The table contains the following data:

Description	Radios
Total radios	100
Enabled	77
Configuration changed	98
DFS channel changed	14
New radios	14
Disabled	23
New neighbors	84
Missing neighbors	82

To the right of this table is a dropdown menu labeled 'Analyze now' and a 'Start' button. Further right is another table titled 'Description' with two columns: 'Description' and a value column. The table contains the following data:

Description	
Elapsed time	-
Estimated time to completion	-
Estimated improvement so far	-
Highest individual AP improvement	-

The following options are available for manual analysis if **Auto-channel** is enabled:

- **Analyze now:** Run the analysis, but do not apply it to the network. This will create two baselines **RRM_BEFORE** and **RRM_AFTER** in the RRM available baselines box.
- **Apply now:** Apply the results of the last analysis to the network.
- **Analyze and Apply:** Run the analysis and automatically apply the results to the network.

When an analysis is in progress, the fields under **Description** will be updated to show progress.

Current network status

Shows the status of the network since the last RRM analysis (baseline) was applied. If nothing has changed in the wireless environment, all fields will have a value of 0 except for the **Total radios**

field. If changes are found, and the numbers are large (compared to the **Total radios** field) then it may be time to run a new analysis to optimize your network.

- **Total radios:** The total number of controlled radios managed by the controller (including legacy radios).
- **Enabled:** The total number of controlled radios that were enabled since the last baseline was applied. (In other words, radios that were disabled in the last baseline but are now enabled.)
- **Configuration changed:** Number of radios whose configuration has changed since the last baseline was applied.
- **DFS channel changed:** The radio detected a radar signal and performed a channel change for DFS reasons after the last baseline was applied.
- **New radios:** The number of new radios added to the controller after the last baseline was applied.
- **Disabled:** The total number of radios that were disabled or deleted since last baseline was applied. (In other words, radios that were enabled in the baseline, but that are now disabled or have been deleted.)
- **Missing neighbors:** Number of neighboring radios that are no longer detected.
- **New neighbors:** New neighboring radios discovered since the last baseline was applied.
- **Elapsed time:** Indicates how long the current analysis has been running.
- **Estimated time to completion:** Estimated time to complete the current analysis.
- **Estimated improvement so far:** Estimated improvement compared to the last applied baseline.
- **Highest individual AP improvement:** The expected performance of each AP is estimated and then compared to the performance of that the last applied baseline. This field then shows the percentage improvement for the AP that improved the most.

Working with baselines

A baseline is a repository that is used to store the auto-channel and auto-power settings for all APs managed by the controller. Baselines allow you to manage RRM settings as required to fine tune the operation of your network. Every time an RRM analysis is run, two baselines are automatically created in the RRM available baselines box:

- An **RRM BEFORE** baseline is created to capture the current channel and power settings in effect on all controlled AP radios, and the wireless scanning data for all non-controlled neighbors. This baseline is created, before the analysis is run.
- An **RRM AFTER** baseline is created to store the results of the analysis once it is complete.

These two baselines are always overwritten each time an analysis is run.

Baselines can also be created manually (up to seven of them) to save the current RRM auto-channel and auto-power settings that are in effect, as well as all wireless scanning data for non-controlled neighbor radios.

In the following example, three baselines have been created. The first two are the standard before and after baselines created by running an analysis.

Base Group: All RRM available baselines						
Name	Description	Created on	Apply	Export	Delete	
RRM BEFORE 2012-07-12 16:25	Created automatically before the RRM analysis was started on 2012-07-12 at 16:25	2012-07-12,16:25:43				
RRM AFTER 2012-07-12 16:25	Created automatically after the RRM analysis was completed on 2012-07-12 at 16:25	2012-07-12,16:25:43				
User-defined baseline	My baseline	2012-07-12,16:31:43				

The third baseline was created by clicking the **Save Current State As Baseline** button. This saves the settings that are currently active on all APs in a new baseline, and lets you name the baseline and add a description to it. For example:

Save RRM baseline

Settings ?

Name: User-defined baseline

Description: My baseline

Cancel Save

To see the contents of a baseline, click its name. For example:

View RRM baseline

Settings ?

Name: RRM_AFTER_2012-11-05_15:45

Description: Created automatically after the RRM analysis was completed on 2012-11-05 at 15:45

Timestamp: 2012-11-05 15:45:20

Total number of radios: 295

Total improvement: 41%

Highest individual AP improvement: 100%

Back

Radio analysis details ?

Number of displayed entries: 5 Show 20 entries

Filter entries by: All columns Apply

MAC address	AP name	Band	Channel After	Current Channel	Power After	Current Power	Current Neighbors
00:24:A8:8A:51:70	SG9142C02P	2.4 GHz	11	1	N/A	20	72
98:4B:E1:1E:D1:D0	CN14D32006	2.4 GHz	6	11	N/A	20	86
98:4B:E1:21:21:30	CN14DLL02L	2.4 GHz	1	11	N/A	20	210
98:4B:E1:1E:D1:C0	CN14D32006	5 GHz	40	153	N/A	26	8
98:4B:E1:21:21:20	CN14DLL02L	5 GHz	161	161	N/A	20	198

(The Radio analysis details box is only displayed for an RRM_AFTER baseline to allow for comparison of the configuration changes suggested by the RRM analysis.)

If a baseline is applied (either manually or automatically), a copy of the baseline is created in the RRM applied baseline box and the last baseline that was applied is moved to the RRM previously applied baseline box.

This is best illustrated with an example:

1. A baseline is manually created by clicking the **Save Current State As Baseline** button. It is named **User-defined baseline** and then applied by clicking the **Apply** button in the RRM available baselines box. A copy is automatically added to the RRM applied baseline box.

Base Group: All RRM applied baseline				
Name	Description	Applied on	Created on	Export
RRM applied baseline	Copy of "User-defined baseline"	2012-07-12,16:31:44	2012-07-12,16:31:43	

2. Next, an analysis is run by selecting **Analyze and Apply**, and then clicking **Start**. The **BEFORE** and **AFTER** baselines are automatically created.

Base Group: All RRM available baselines						
Name	Description	Created on	Apply	Export	Delete	
RRM BEFORE 2012-07-12 16:25	Created automatically before the RRM analysis was started on 2012-07-12 at 16:25	2012-07-12,16:25:43				
RRM AFTER 2012-07-12 16:25	Created automatically after the RRM analysis was completed on 2012-07-12 at 16:25	2012-07-12,16:25:43				
User-defined baseline	My baseline	2012-07-12,16:31:43				

3. After the analysis completes, the **AFTER** baseline is automatically applied and the **User-defined baseline** is moved to the **RRM previously applied baseline** box. This allows you to revert to a previous baseline if a newly-applied baseline does not suit your needs.

Base Group: All RRM applied baseline				
Name	Description	Applied on	Created on	Export
RRM applied baseline	Copy of "RRM_AFTER_2012-07-12_16:25"	2012-07-12,16:31:57	2012-07-12,16:25:43	

10 Intrusion detection system (IDS)

The intrusion detection system offers administrators the ability to proactively detect potential threats to the wireless network. When enabled, IDS will detect and classify all wireless APs and client stations operating within range providing a complete picture of all wireless activity in the area.

Supported products

IDS is available in controlled mode only. It is supported on the following products:

- HP MSM720 (Requires the Premium Mobility Controller license.)
- HP MSM760 (Requires the Premium Mobility Controller license.)
- HP MSM765 zl (Requires the Premium Mobility Controller license.)
- HP MSM775 zl (Requires the Premium Mobility Controller license.)
- HP MSM410
- HP 425
- HP MSM430
- HP MSM460
- HP MSM466/466-R

All IDS features will work on controller teams.

AP classification

AP classification is done through the use of automatic classification policies and manual overrides that can be used by the administrator to address specific topology/environmental considerations. Manual categorization will override automatic classification.

When relying solely on automatic classification, APs will be classified as follows:

- **Authorized APs:** APs that are discovered and managed by the controller (controlled mode APs) are automatically classified as *Authorized*. You can also manually configure a list of non-controlled APs that IDS should consider to be *Authorized*. Generally, these would be third-party APs that you are aware of and are directly connected to the wired network.
- **Rogue APs:** APs that are found to be connected to the wired network and not *Authorized* are classified as *Rogue*.
- **External APs:** There are APs that are not managed by the controller and are not connected to the wired network. Essentially, these are APs that are not classified as either *Authorized* or *Rogue*. Examples include in-range APs from neighboring companies, and autonomous APs.

The presence of non-sanctioned wireless APs (and ad-hoc networks) is potentially a very serious security threat. IDS detects the following wireless network threats:

- Rogue APs
- Man-in-the-middle
- DoS disassociation flood
- DoS disassociation broadcast
- DoS association flood
- DoS deauthentication flood
- DoS deauthentication broadcast
- DoS authentication flood

- DoS EAPOL logoff flood
- DoS EAPOL start flood
- DoS Premature EAP success
- DoS Premature EAP failure
- DoS Beacon CFP
- DoS PS-Poll
- Bridging STP
- Misbehaving clients
- Ad-hoc networks
- Bridging

Wireless client classification

Automatic classification policies also divide clients into distinct groups. (Manual classification by the administrator is not supported.) The following classifications are supported:

- **Authorized clients:** Clients that are either currently associated or have previously successfully associated with a secure VSC on a controlled AP. (Note: In this context, a secure VSC is considered to be a VSC with any type of security enabled: WPA, 802.1x, or WEP.)
- **Non-authorized clients:** Clients that never successfully associated with a secure VSC.
- **Mis-associated clients:** Clients that have been classified as *Authorized* but are found to be associated to rogue or external APs.

IDS automatically builds and maintains a database of authorized clients and tracks when the device last associated to a secure VSC. When teaming is active, the database is replicated to other controllers in the team. In the unlikely event that the database size limit is reached, the oldest entries are dropped.

IDS detects and reports the following wireless threats for client devices:

- Authorized clients participating in an ad-hoc network
- Authorized client mis-associations
- Bridging: Clients in Bridging/Windows Internet Connection Sharing (ICS) configuration
- Bridging: STP detection

Threat detection

IDS detects and reports the following wireless threats for client devices:

- Authorized clients participating in an ad-hoc network
- Authorized client mis-associations
- Bridging: Clients in Bridging/Windows Internet Connection Sharing (ICS) configuration
- Bridging: STP detection

802.11 is susceptible to a variety of denial-of-service (DoS) attacks that will impact the performance and reliability of a wireless network. IDS detects and reports the following DoS attacks:

- Disassociation flood attack in progress
- Disassociation broadcast attack in progress
- Association flood attack in progress
- Deauthentication flood attack in progress

- Deauthentication broadcast attack in progress
- Authentication flood attack in progress
- EAPOL Logoff flood attack in progress
- EAPOL Start flood attack in progress
- Premature EAP Success attack in progress
- Premature EAP Failure attack in progress
- Beacon packet with large Contention Free Period (CFP) duration detected
- PS-Poll attack in progress

IDS modes

Three modes of operation are available:

- **AP mode:** In this mode, besides offering client services, background scanning is performed on the operating channel (0.5% of the time by default). Although limited in scope compared to a full spectrum scan, threat detection time for many threats (DoS threats in particular) is short because the AP is monitoring the active channel. To configure a radio to operate in this mode, make the following settings on the Radio configuration page:
 - Set **Wireless mode** to **Access Point**.
 - Under **Neighborhood scanning**, set **Scan ratio** to a low value (0.5% is the default).
- **Dedicated IDS mode:** In this mode, no client services are offered and radio is dedicated for IDS capabilities. By default, active scanning takes place on both the 2.4 GHz and 5 GHz bands (it can be limited to a single band if required). To configure a radio to operate in this mode, make the following setting on the Radio configuration page:
 - Set **Wireless mode** to **Monitor**.
- **Hybrid mode:** In this mode, significant time time-slicing takes place so client services and IDS capabilities can be offered simultaneously. Scanning of non-operating channels takes place within the allocated time-slice. To configure a radio to operate in this mode, make the following settings on the Radio configuration page:
 - Set **Wireless mode** to **Access Point**.
 - Under **Neighborhood scanning**, set **Scan ratio** to a value that provides the rogue detection time you need with the smallest possible effect on performance. A good starting point would be a ratio between 5% and 10%, and then increase if needed.

In hybrid mode, the radio transmits a CTS-to-self frame just before it goes off-channel. This frame is an indication to client devices that they should not send frames to the radio. This reduces (somewhat) the impact of the radio being non-responsive during the off-channel dwell-time.

Voice traffic is particularly sensitive to an unresponsive radio, so in hybrid mode, the off-channel scanning is disabled completely while voice traffic is active on the radio.

IDS determines whether voice traffic is active by monitoring the QoS queues used for the voice access category (AC_VO).

Deployment strategy

The mode(s) of operation you choose will depend on the deployment strategy for your wireless network: overlay, time-slicing, or hybrid (a combination of overlay and time-slicing). Each method has its strengths and weaknesses as follows:

- **Overlay:** When using this strategy, some of the 802.11 radios in the wireless network are configured to operate as dedicated IDS sensors. These radios do not offer access point services, and spend 100% of the time scanning for IDS threats. The radios operating as sensors are generally deployed to provide the same coverage as the radios providing wireless services. Essentially, IDS scanning overlays the entire wireless network, or key parts of it.
- **Time-slicing:** When using this strategy, the radios that provide wireless services also devote a percentage of their time to IDS scanning (either on-channel only, or across all operating channels). This method provides complete coverage but with reduced performance.
- **Hybrid:** This strategy uses both overlay and time-slicing at the same time in different areas in the network as appropriate.

When choosing a deployment strategy, consider the following:

Consideration	Overlay	Time-slicing
Coverage The IDS solution must be capable of detecting threats throughout the wireless network, with no areas hidden from the IDS sensor radios.	Placement of the IDS sensor radios must be carefully planned in advance to provide complete coverage. This method will also require more APs. For example, an overlay of 1 sensor radio per 6 AP radios means purchasing 16% more APs. It can be difficult to do a sparse overlay because the sensors may be too far apart to effectively cover the required area.	IDS coverage will match wireless coverage because every AP acts as an IDS sensor.
AP performance Delivery of wireless services can be affected by the scanning method.	No effect since the radios that perform IDS scanning are different from those that provide wireless services.	APs spend part of their time scanning for wireless threats, resulting in reduced wireless performance.
Threat detection To detect a wireless threat, an IDS sensor must hear the wireless frames that embody the threat.	All threats are found faster due to dedicated scanning.	In-channel threats (such as denial-of-service threats) are found almost as fast as the overlay solution. Off-channel threat detection may take up to twice as long.

Rogue detection example

To detect a rogue AP, the IDS system must monitor all channels in the wireless space looking for beacon frames transmitted by the rogue AP's radio. Typically, 10 beacon frames are transmitted per second by a radio.

- If using an overlay strategy, the IDS sensors must scan all 38 channels. Assuming a dwell time of 110 milliseconds, it can take up to 4 seconds to detect the rogue radio.
- If using a time-slicing strategy, detection time depends on the off-channel scan rate. If a radio is set to a scan ratio of 5%, then mathematically it should take up to 20 times longer (80 seconds) than the overlay method. However, due to the way scanning is performed, the actual time will be closer to 160 seconds. This would be true for a single, isolated radio. If several radios are neighbors, and provide overlapping coverage, the time to find a rogue AP radio is reduced. For example, if several radios are deployed in a classic hex-cell pattern, each radio has 6 neighbors, so detect time goes down by a factor of approximately 7. So, 160 seconds is reduced to approximately 23 seconds.

Configuration considerations for VoIP traffic

If your wireless network supports VoIP traffic, consider the following:

- If voice traffic is detected on a radio (i.e., the traffic is marked with a QoS setting of AC_VO), background scanning is disabled on the radio. Not all VoIP traffic is properly QoS-tagged. Scanning will not be disabled for this traffic.
- Setting a high dwell time (under Neighborhood scanning on the Radio page), may cause packet loss in VoIP traffic. The potential delay for a VoIP frame is equal to the dwell time. The maximum recommended delay for VoIP traffic is 100 ms (unidirectional).
- For best results, configure a low scan rate by reducing scan ratio and dwell time under Neighborhood scanning on the Radio page. For example, setting scan rate to 0.1% and dwell time to 10 ms results in one scan-slot every 30 seconds.
- Setting the **Traffic shaping** feature (on the Radio configuration page) to **Airtime fairness** can help. Airtime fairness gives every client device an equal share of air time. VoIP devices need little air time, so when competing with other devices, the VoIP device will be at the head of the line. Without Airtime fairness, air time allocation is more on a first-come, first-served basis.

Teaming considerations

IDS is supported on controller teams. However, in the case of multiple teams, manual classification may be required to avoid situations where the authorized AP on one team is detected as a rogue AP by another team.

Starting IDS

This procedure assumes the controller has a Premium Mobility Controller license installed.

1. Select **Controller >> Security > IDS**.

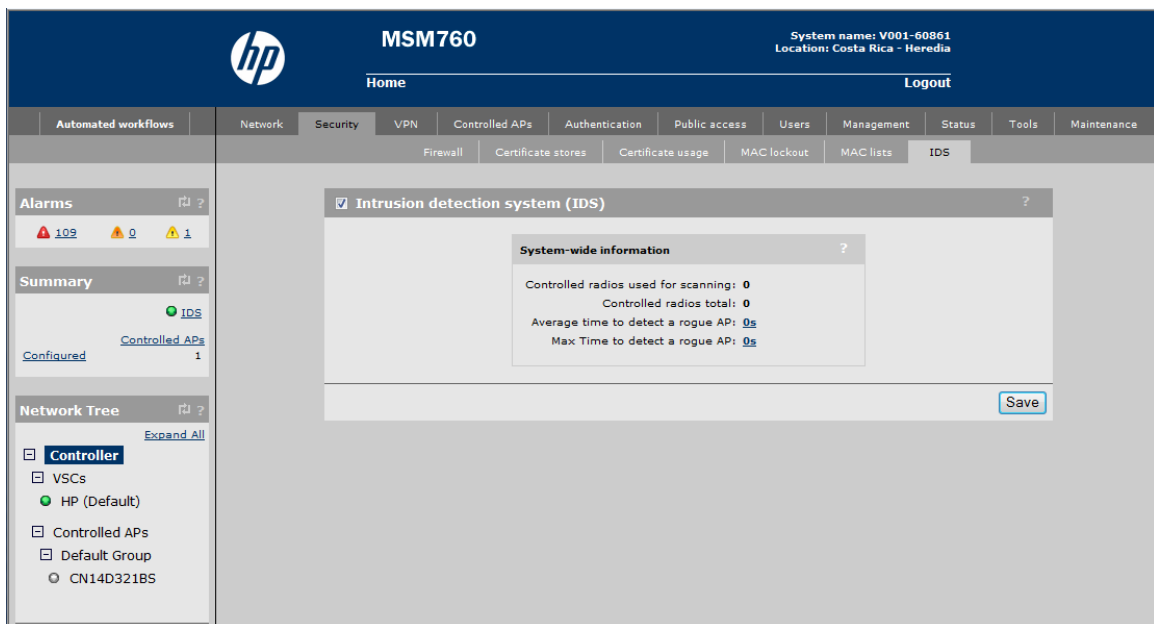

2. Enable the checkbox and click **Save**. Once enabled, the IDS icon in the Summary box will turn green.
3. To detect rogue APs, IDS needs connectivity to all VLANs in use by the network. By default, APs monitor the network on which the management tunnel with the controller is established, they also monitor any VLANs that are mapped to the APs on the **Controlled APs >> Configuration > VLANs** page. If you want to other VLANs (for example, VLANs that are used

by other devices on your network), you need to create special network detector VLAN assignments as follows:

4. To detect rogue APs, IDS needs connectivity to all VLANs in use by the network. By default, APs monitor the network on which the management tunnel with the controller is established. If your network has other VLANs, it requires that you define one or more APs with network detector capabilities as follows:
 - a. Select **Controlled APs >> Security > Network detector**.
 - b. Enable this option to have IDS retrieve information from the network detector feature on the APs. If you select an individual AP in the Network Tree, you can define the VLAN on which the network detector will operate.

AP: SG103C508J | Network detector Inherited

Network Detector ?

Enabled Disabled

Save

Network detector VLAN configuration ?

VLAN	IP address	Mask
IDS_network_detector_static (192)	192.168.2.222	255.255.255.0

Add New VLAN...

- c. Click **Add New VLAN**.

AP: SG103C508J | Add/Edit VLAN

VLAN ?

VLAN ID: 213 (IDS_network_detector)

Assign IP address via ?

DHCP client

Static

IP address:

Mask:

Gateway:

Cancel Delete Save

- d. Click **Save** when done.

AP: SG103C508J | Network detector Inherited

Network Detector ?

Enabled Disabled

Network detector VLAN configuration ?

VLAN	IP address	Mask
IDS_network_detector_dhcp (213)	10.213.2.232	255.255.0.0
IDS_network_detector_static (192)	192.168.2.222	255.255.255.0

Customizing scanning settings

To customize scanning settings for an AP, select **Controlled APs >> Radio management** and then select the AP in the list.

Scanning is controlled by the option selected for **Operating mode** and the settings under **Neighborhood scanning**. Scanning services are used by both RRM (radio resource management) and IDS (intrusion detection system).

Available options are different depending on the **Operating mode**. For example:

Radio 2 ?

Regulatory domain: **UNITED STATES**

Operating mode: Access point only

Wireless mode: 802.11n/b/g

Channel width: 20 MHz

Channel: Automatic

* = DFS [Important note](#)

Interval: Time of Day

Time of day: 01 *hh* 00 *mm*

Automatic channel exclusion list:
 Channel 1, 2.412GHz
 Channel 2, 2.417GHz
 Channel 3, 2.422GHz

Antenna gain: 2 dBi

Max clients: 255

Advanced wireless settings

Neighborhood scanning

Scan ratio: 0.5 %

Dwell time: 30 *ms*

Scanning mode: Active

Bands to scan: All bands

Channels to scan: All channels

Neighbor detection time: 2964 s

Radio 2 ?

Regulatory domain: **UNITED STATES**

Operating mode: Monitor

Wireless mode: 802.11n/b/g

Channel width: 20 MHz

Channel: Automatic

* = DFS [Important note](#)

Neighborhood scanning

Dwell time: 30 *ms*

Scanning mode: Active

Channels to scan: All channels

The scanning mode that an AP uses is determined by the setting of **Operating mode**.

- **Access point only:** In these modes, scanning operates in the background. The radio periodically switches away from the operating channel for a short period of time to listen for activity on non-operating channels. The amount of time dedicated for scanning is defined by the settings you make for **Neighborhood scanning**.
- **Monitor:** In this mode, the radio only performs scanning. Wireless services are not available.
- **Local mesh only** and **Access point and Local mesh:** Scanning is not supported in these modes.

Neighborhood scanning settings

IDS uses the same scanning settings as RRM. For details, see “[Neighborhood scanning settings](#)” (page 186).

Viewing IDS results

To view the results of IDS scans, select **Controlled APs >> Security**, and then view the following pages.

IDS page

This page provides a summary of IDS activity across all groups and APs. Click a group name to see IDS information for a single group only.

The screenshot displays the HP MSM760 web interface for the IDS (Intrusion Detection System) page. The page title is "MSM760" and the system name is "V001-60861" located in "Costa Rica - Heredia". The navigation menu includes "Home" and "Logout". The main navigation tabs are "Automated workflows", "Overview", "Configuration", "Radio management", "Group management", "Security", "Tools", and "Provisioning". The "Security" tab is active, and the "IDS" sub-tab is selected. The page shows a "Base Group: All" for the "Intrusion detection system (IDS)". A "Context information" box displays the following data: "Controlled radios used for scanning: 0", "Controlled radios total: 0", "Average time to detect a rogue AP: 0s", and "Max Time to detect a rogue AP: 0s". Below this, a "Groups" section shows "Number of matching IDS elements: 1" and a "Show 10 entries" dropdown. A table lists the groups with columns for "Groups", "Scanning radios", "Total radios", "Average time", and "Worst time". The table contains one entry for "Default Group" with all values set to 0. The left sidebar shows a "Network Tree" with "Controlled APs" expanded, listing "HP (Default)" and "Default Group" (CN14D321BS). The bottom of the page has navigation links: "First Previous 1 Next Last".

Context information

- **Controlled radios used for scanning:** Number of radios on all controlled APs that are participating in IDS scanning.
- **Controlled radios total:** Total number of radios on all controlled APs.

- **Average time to detect a rogue AP:** Estimated time to detect a rogue AP, averaged across all radios that are scanning.
- **Max Time to detect a rogue AP:** Longest amount of time to detect a rogue AP for all radios that are scanning.

Groups

- **Group:** Group name.
- **Scanning radios:** Number of radios that are performing IDS scanning in the group.
- **Total radios:** Total number of radios on all APs in the group.
- **Average time:** Estimated time to detect a rogue AP, averaged across all radios that are scanning in the group.
- **Worst time:** Longest amount of time to detect a rogue AP for all radios that are scanning in the group.

Mis-associated client stations page

This page lists client stations that have been classified as *Authorized*, but are found to be associated to rogue or external APs, or part of an adhoc-cell.

Base Group: All Mis-associated client stations					
Number of mis-associated client stations: 2					Show 25 entries
Filter mis-associated client stations by: MAC address					Apply
MAC address	Association type	BSSID	BSSID AP classification	Channel	SSID
A4:D1:D2:9B:13:35	BSS (AP)	2C:41:38:F8:CF:A0	External	36	[Empty SSID]
B0:48:7A:89:61:C6	IBSS (Ad-hoc)	0A:F3:05:1A:75:72	External	9	[Empty SSID]

First Previous 1 Next Last

Click the **MAC address** for a station to see detailed information. For example:

Mis-associated client station details ?

Mis-associated client station information

MAC: **04:1E:64:85:2A:85**
 Association type: **BSS (AP)**
 Classification: **Rogue**
 Associated radio: **00:24:A8:BD:B5:80**
 HT capability: **Unknown**
 Detection time stamp: **2012-12-05 10:39:56**

Detected by these controlled IDS radios

Detected by **1** radios Show **10** entries

Radio	Signal strength
E8:39:35:F1:33:8D	6

First Previous **1** Next Last

[Back](#)

Ad-hoc cells page

Shows all devices that are providing wireless services but are not access points. For example, if a user sets up their laptop to create a wireless network to share files with co-workers. The ad-hoc cell remains active until the last user connected to it shuts it down.

Base Group: All | Ad-hoc cells ?

Number of matching ad-hoc cells: **2** Show **25** entries

Filter ad-hoc cells by: **Cell ID** Apply

Cell ID	SSID	Band	Channel	Stations	Authorized stations
46:2D:2F:BB:46:00		2.4GHz	6	1	0
46:9D:24:58:39:18	IDS_Adhoc_testing	2.4GHz	1	2	0

First Previous **1** Next Last

Click the **MAC address** for a device to see detailed information. For example:

External Ad-hoc cells details

Ad-hoc cell information

Cell ID: 46:9D:24:58:39:18
 SSID's: IDS_Adhoc_testing
 Channel: 1
 Stations: 2
 Authorized stations: 0
 Security: WPA2
 Detection timestamp: Jul 19 2012, 13h17m

Stations associated

Show 10 entries

MAC address	Security
No data available in table	

First Previous Next Last

Detected by these controlled IDS APs

Show 10 entries

AP	Signal strength
No data available in table	

First Previous Next Last

Back

Neighborhood page

This page shows the results of IDS scanning. Refer to the **Classification** column to find rogue AP radios. By default, rogues are shown at the top of the list.

Base Group: All | Neighborhood

Number of matching radios: 24 of 105 (Clear filter)

Show 20 entries

Show controlled radios

Current filters: Mode: 802.11n (2.4 GHz)

Filter radios by: Mode 802.11n (2.4 GHz) Apply

Select the action to apply to the selected radios: - Select an action - Apply

<input type="checkbox"/>	MAC address	SSIDs	Mode	Channel	SNR	Info	Classification	Last seen
<input checked="" type="checkbox"/>	64:31:50:DE:6C:60	1	802.11n (2.4 GHz)	1	10	ESS	Rogue	2012-12-04 13:52:34
<input type="checkbox"/>	00:24:A8:1B:95:60	1	802.11n (2.4 GHz)	6	34	ESS	External	2012-12-04 13:52:35
<input type="checkbox"/>	00:24:A8:8A:51:70	1	802.11n (2.4 GHz)	1	10	ESS	External	2012-12-04 13:52:35
<input type="checkbox"/>	00:24:A8:BD:A5:D0	1	802.11n (2.4 GHz)	1	19	ESS	External	2012-12-04 13:52:35
<input type="checkbox"/>	00:24:A8:BD:B5:80	1	802.11n (2.4 GHz)	1	25	ESS	External	2012-12-04 13:52:44
<input type="checkbox"/>	00:24:A8:BE:37:50	1	802.11n (2.4 GHz)	11	22	ESS	External	2012-12-04 13:52:36
<input type="checkbox"/>	00:24:A8:BE:3F:10	1	802.11n (2.4 GHz)	6	25	ESS	External	2012-12-04 13:52:50
<input type="checkbox"/>	00:24:A8:BE:4F:B0	1	802.11n (2.4 GHz)	11	26	ESS	External	2012-12-04 13:52:36
<input type="checkbox"/>	00:24:A8:BE:57:60	1	802.11n (2.4 GHz)	1	6	ESS	External	2012-12-04 13:52:32
<input type="checkbox"/>	00:30:AB:2A:6B:C0	1	802.11n (2.4 GHz)	2	11	ESS	External	2012-12-04 13:52:35
<input type="checkbox"/>	10:60:4B:F2:55:B0	1	802.11n (2.4 GHz)	6	6	ESS	External	2012-12-04 13:52:32
<input type="checkbox"/>	2C:76:8A:F9:CB:50	1	802.11n (2.4 GHz)	6	23	ESS	External	2012-12-04 13:52:35
<input type="checkbox"/>	64:31:50:E1:15:01	1	802.11n (2.4 GHz)	1	6	ESS	External	2012-12-04 13:52:44
<input type="checkbox"/>	64:31:50:E1:CE:41	1	802.11n (2.4 GHz)	4	13	ESS WPA/WPA2	External	2012-12-04 13:52:35
<input type="checkbox"/>	80:C1:6E:36:A7:90	1	802.11n (2.4 GHz)	11	6	ESS	External	2012-12-04 13:52:32

First Previous 1 Next Last

Statistics Last updated: 2012-12-04 15:00:53 Import/Export...

Table

- **MAC address:** MAC address of the radio. Click the address to see detailed information about the AP.
- **SSID:** SSID on which the radio is broadcasting.
- **Mode:** Wireless mode in which the radio is operating.
- **Channel:** Channel on which the radio is operating.
- **SNR:** Signal to noise ratio detected.
- **Info:** Encryption being used.
- **Classification:** Classification is done through the use of automatic classification policies and manual overrides that can be used by the administrator to address specific topology/environmental considerations. Manual categorization (see the next section) will override automatic classification. When relying solely on automatic classification, AP radios will be classified into three distinct groups:
 - **Authorized:** AP radios that are discovered and managed by the controller (controlled mode APs) are automatically classified as *Authorized*. You can also manually configure a list of non-controlled APs that IDS should consider to be *Authorized*. Generally, these would be third-party APs that you are aware of and are directly connected to the wired network.
 - **External:** These are AP radios that are not managed by the controller and are not connected to the wired network. Essentially, these are radios that are not classified as either *Authorized* or *Rogue*. For example, in-range radios from neighboring companies.
 - **Rogue:** AP radios that are found to be connected to the wired network and not *Authorized* are classified as *Rogue*.
- **Last seen:** Date and time the radio was last detected.

Rogue AP details

This page provides more detailed information on a rogue AP.

Rogue AP details ?

AP information

BSSIDs: **2C:41:38:F8:CF:A0**
 SSID's: **IDS_Rogue_testing**
 Channels: **36, 5.180GHz**
 Classification: **Rogue**
 Manual override: **False**
 Last seen: **Jul 18 2012, 16h32m**
 Security: **WPA/WPA2**
 Authentication: **Preshared Key**
 HT capability: **HT Capable**
 Detection timestamp: **Jul 19 2012, 14h29m**
 Network connectivity: **192.168.1.0/24**

Detected by

Detected by 2 APs Show 10 entries

AP	Signal strength
00:24:A8:87:A5:E3	85
F0:62:81:48:00:D0	16

First Previous 1 Next Last

Back

AP information

- **BSSIDs:** MAC addresses of the AP. Click the address to see detailed information about the AP.
- **SSIDs:** SSIDs on which the AP is broadcasting.
- **Channels:** Channels on which the AP is operating.
- **Classification:** Rogue.
- **Manual override:** Indicates if the AP was classified manually by the administrator or automatically by the controller.
- **Info:** Encryption being used.
- **Last seen:** Date and time the AP was last detected.
- **Security:** Type of security active on the AP.
- **Authentication:** Authentication method.
- **HT compatibility:** Indicates the APs high-throughput capability.
- **Detection timestamp:** Date and time the AP was first detected.
- **Network connectivity:** IP address and mask.

Detected by

- **AP:** MAC address of the AP that detected the radio.
- **Signal strength:** Indicates the strength of the radio signal received from the AP. Signal strength is expressed in decibel milliwatt (dBm). The higher the number the stronger the signal.

Manually changing AP radio classification

By default, IDS will classify all detected radios. It may be necessary to adjust these classifications based on your knowledge of the network.

For example, to change a rogue radio to authorized, do the following:

1. Select the radio that you want to classify as authorized.
2. Select the **Classify radio as authorized** action.

Base Group: All | Neighborhood
Number of matching radios: 99 of 105 [\(Clear filter\)](#) Show 20 entries

Show controlled radios Filter radios by: MAC address

Select the action to apply to the selected radios:

<input type="checkbox"/>	MAC address	SSIDs	Mode	Channel	SNR	Info	Classifica	
<input checked="" type="checkbox"/>	64:31:50:DE:6C:60	1	802.11n (2.4 GHz)	1	10	ESS	Rogue	
<input type="checkbox"/>	00:03:52:81:B4:A0	1	802.11b/g	8	28	ESS	External	2012-12-04 13:52:50
<input type="checkbox"/>	00:03:52:8A:89:00	1	802.11b/g	7	9	ESS	External	2012-12-04 13:52:32
<input type="checkbox"/>	00:03:52:8D:5A:70	1	802.11n/a	161	55	ESS	External	2012-12-04 13:52:36
<input type="checkbox"/>	00:03:52:8E:46:A0	1	802.11n/a	157	18	ESS WPA2	External	2012-12-04 13:52:53
<input type="checkbox"/>	00:03:52:8E:4B:61	1	802.11n/a	149	24	ESS WPA	External	2012-12-04 13:52:36
<input type="checkbox"/>	00:03:52:91:FB:21	1	802.11b/g	2	28	ESS	External	2012-12-04 13:52:44
<input type="checkbox"/>	00:0F:61:51:5D:30	1	802.11b/g	4	44	ESS	External	2012-12-04 13:52:35
<input type="checkbox"/>	00:0F:61:52:57:B0	1	802.11b/g	7	43	ESS	External	2012-12-04 13:52:35
<input type="checkbox"/>	00:0F:61:52:58:20	1	802.11b/g	10	34	ESS	External	2012-12-04 13:52:36
<input type="checkbox"/>	00:0F:61:52:E1:60	1	802.11b/g	3	7	ESS	External	2012-12-04 13:52:35
<input type="checkbox"/>	00:0F:61:81:A6:E0	1	802.11b/g	11	26	ESS WPA2	External	2012-12-04 13:52:36
<input type="checkbox"/>	00:0F:61:8D:68:30	1	802.11n/a	161	46	ESS WPA2	External	2012-12-04 13:52:36
<input type="checkbox"/>	00:0F:61:8D:68:85	1	802.11n (5 GHz)	140	17	ESS WPA2	External	2012-12-04 13:52:38
<input type="checkbox"/>	00:0F:61:BC:2D:B0	1	802.11n/a	44	18	ESS	External	2012-12-04 13:52:34

First Previous 1 2 3 4 Next Last

Statistics Last updated: 2012-12-04 14:59:01

3. Click **Apply**. The rogue radio is changed to **Authorized** and the indicator **Manual** appears next to the classification.

Base Group: All | Neighborhood

Number of matching radios: 94 of 101 [\(Clear filter\)](#) Show 20 entries

Show controlled radios

Filter radios by: MAC address

Select the action to apply to the selected radios:

<input type="checkbox"/>	MAC address	SSIDs	Mode	Channel	SNR	Info	Classification	Last seen
<input type="checkbox"/>	64:31:50:DE:6C:60	1	802.11n (2.4 GHz)	1	10	ESS	Authorized (manual)	2012-12-04 13:52:34
<input type="checkbox"/>	00:03:52:81:B4:A0	1	802.11b/g	8	28	ESS	External	2012-12-04 13:52:50
<input type="checkbox"/>	00:03:52:8A:89:00	1	802.11b/g	7	9	ESS	External	2012-12-04 13:52:32
<input type="checkbox"/>	00:03:52:8D:5A:70	1	802.11n/a	161	55	ESS	External	2012-12-04 13:52:36
<input type="checkbox"/>	00:03:52:8E:46:A0	1	802.11n/a	157	18	ESS WPA2	External	2012-12-04 13:52:53
<input type="checkbox"/>	00:03:52:8E:4B:61	1	802.11n/a	149	24	ESS WPA	External	2012-12-04 13:52:36
<input type="checkbox"/>	00:03:52:91:FB:21	1	802.11b/g	2	28	ESS	External	2012-12-04 13:52:44
<input type="checkbox"/>	00:0F:61:51:5D:30	1	802.11b/g	4	44	ESS	External	2012-12-04 13:52:35
<input type="checkbox"/>	00:0F:61:52:57:B0	1	802.11b/g	7	43	ESS	External	2012-12-04 13:52:35
<input type="checkbox"/>	00:0F:61:52:58:20	1	802.11b/g	10	34	ESS	External	2012-12-04 13:52:36
<input type="checkbox"/>	00:0F:61:52:E1:60	1	802.11b/g	3	7	ESS	External	2012-12-04 13:52:35
<input type="checkbox"/>	00:0F:61:81:A6:E0	1	802.11b/g	11	26	ESS WPA2	External	2012-12-04 13:52:36
<input type="checkbox"/>	00:0F:61:8D:68:30	1	802.11n/a	161	46	ESS WPA2	External	2012-12-04 13:52:36
<input type="checkbox"/>	00:0F:61:8D:68:85	1	802.11n (5 GHz)	140	17	ESS WPA2	External	2012-12-04 13:52:38

Statistics Last updated: 2012-12-05 10:47:47

Importing/exporting IDS classifications

The information that appears on the Neighborhood page can be exported as a CSV file for use in other applications. You can also import information, in the same CSV format. This is useful when you need to classify a large number of APs. For example, if you have manually classified the APs detected on one controller, you can export and then import these definitions on a second controller. Also, in a situation where two teams are in proximity, you can export the list of APs from one team and import it into the other.

Import/Export IDS AP classification ?

Import

Filename:

Export

Controlled APs

Manually classified APs

11 Events and alarms

The events and alarms features provides a logging and notification system that can be used by administrators and support personnel to easily monitor and troubleshoot system issues.

Note: For backward compatibility, the system log feature that was available in previous releases is still available on the **Controller >> Tools** menu.

Supported products

- HP MSM720
- HP MSM760
- HP MSM765 zl
- HP MSM775 zl
- HP MSM3xx (Events only)
- HP MSM410 (Events only)
- HP MSM422 (Events only)
- HP 425 (Events only)
- HP MSM430 (Events only)
- HP MSM460 (Events only)
- HP MSM466/466-R (Events only)
- HP 517 (Events only)

Events

An event is the occurrence of a condition that has been detected in the network infrastructure. For example, wireless client association/disassociation, radios turned on/off, radio power/channel changes and more. A record of events is typically stored over relatively long periods of time to assist with OAM&P and auditing activities.

A new Events page has been created on the Tools menu that replaces and enhances the old client event log. The following screen capture shows the Events page with a number of events.

Severity	ID	Device	Category	Type	Alarm	Description	Timestamp
●	45	SG9163P01T	System	System administrator successfully authenticated		An administrator has successfully been authenticated.	Nov 17 13:04:44
●	44	SG9163P01T	System	System time server is unreachable		The system time server is unreachable.	Nov 17 13:04:16
●	43	SG9163P01T	System	System time server is unreachable		The system time server is unreachable.	Nov 17 13:04:06
●	42	SG9163P01T	System	System time server is unreachable		The system time server is unreachable.	Nov 17 13:02:56
●	41	SG9163P01T	System	System time server is unreachable		The system time server is unreachable.	Nov 17 13:02:46
●	40	SG9163P01T	System	System administrator logged out		An administrator has logged out.	Nov 17 13:02:37
●	39	SG9163P01T	System	System time server is unreachable		The system time server is unreachable.	Nov 17 13:01:36
●	38	SG9163P01T	System	System time server is unreachable		The system time server is unreachable.	Nov 17 13:01:26

The Severity, Device, Alarm, and Timestamp columns display detailed information if you hover the mouse pointer over an entry in the table as shown.

You can also sort events in any column (except Description) by clicking the column title.

Filter events by

To see only a subset of all events, select a filter condition and click **Apply**. Filters are saved across sessions and can be cleared by selecting **Clear filters**. To see only a subset of all events, select a filter condition and click **Apply**.

Filters are saved across sessions and can be cleared by selecting **Clear filters**.

Table

Severity

- **Critical (Red):** Events of this type indicate a failure and signal the need for immediate attention.
- **Major (Orange):** Events of this type indicate an impending failure.
- **Minor (Yellow):** Events of this type indicate a warning condition that can escalate into a more serious problem.
- **Informational (Green):** Events of this type require no action. They are provided for information purposes.

ID

Unique number assigned to the event.

Device

Indicates the device that detected the event. Hover the mouse pointer over the device name to see the device type and its MAC address.

Category

Events are classified into categories so that they can be sorted. Categories include:

- 802.1X
- Controlled AP
- DHCP
- IDS
- MAC Authentication
- Maintenance
- MTM
- Public Access
- REI
- RRM
- Teamed Controller
- Teaming
- Wireless
- WPA
- VPN
- VSC

Type

Classifies the event within a category.

Alarm

If an event triggers an alarm, the appropriate alarm indicator appears in this column. Hover the mouse pointer over the alarm to see its severity and ID. The association between an event and an alarm is predefined and is not configurable.

Description

Detailed information about the event.

Timestamp

Date and time that the event occurred.

Button

Export

Click this button to export all the events that are visible in the table to a CSV (comma-separated values) file for use in other applications.

Alarms

The new Alarms page provides administrators with a centralized place to monitor and manage important notifications from the system.

Alarms are triggered by specific events and can be cleared automatically or manually. The events that trigger an alarm are predefined and cannot be changed. Alarms are not available on autonomous APs.

Viewing/managing alarms

A summary count of all active alarms is presented in the left pane in the Alarm box. To view alarm details, select the alarm count or select **Controller >> Tools > Alarms**. For example:

The screenshot shows the HP MSM760 management interface. The top navigation bar includes the HP logo, 'MSM760', and 'System name: V001-60861'. Below the navigation bar, there are tabs for 'Automated workflows', 'Alarms', 'Events', 'System log', 'Remote log', 'User tracking', 'IPSec', 'System tools', 'Network trace', 'Ping', and 'sFlow'. The 'Alarms' tab is active, displaying a table of alarms. The table has columns for Severity, ID, Device, Category, Type, Description, Timestamp, Ack, Note, and State. There are three alarms listed:

Severity	ID	Device	Category	Type	Description	Timestamp	Ack	Note	State
Warning	3	V001-60861	System	Maintenance	A certificate will expire on (date="2012-07-17") .	Jul 16 13:02:12	✓		●
Critical	2	V001-60861	System	AP death	AP 00:00:00:00:00:00 is dead.	Jul 16 12:52:53			●
Warning	1	V001-60861	System	Maintenance	Local configuration has changed	Jul 15 11:03:15			●

The Severity, Device, Timestamp, Ack, State columns display detailed information if you hover the mouse pointer over an entry in the table as shown.

You can also sort alarms in any column by clicking the column title (except the Description column).

Select the action to apply to the selected alarm

Lets you apply an action to all selected alarms in the list. Select an action and then click **Apply**.

- **Acknowledge:** Marks the selected alarms as acknowledged. An acknowledged alarm is not cleared. The acknowledgment serves as an indicator that an administrator is aware of the alarm.
- **Unacknowledge:** Returns the selected alarms to the acknowledged state.
- **Clear:** Alarms of this type indicate a warning condition that can escalate into a more serious problem.

Filter alarms by

To see only a subset of all alarms, select a filter condition and click **Apply**. Filters are saved across sessions and can be cleared by selecting **Clear filters**.

Table

Severity

- **Critical (Red):** Alarms of this type indicate a failure and signal the need for immediate attention.
- **Major (Orange):** Alarms of this type indicate an impending failure.
- **Minor (Yellow):** Alarms of this type indicate a warning condition that can escalate into a more serious problem.

ID

Number assigned to the alarm.

Device

Indicates the device that generated the alarm. Hover the mouse pointer over the device name to see the device type and its MAC address.

Category

Alarms are classified into categories so that they can be sorted. Categories include:

- Controlled AP
- IDS
- MAC Authentication
- Maintenance
- Public Access
- REI
- RRM
- System
- Teamed Controller

Type

Classifies the alarm within a category.

Description

Click the description to see complete details on the alarm. It also enables you to add an annotation to the alarm, to acknowledge it, clear it, and to set the alarm state. For example:

Alarm details ?

Severity: Critical

ID: 4

Device: CN1ZF99057

Category: System

Type: Controller unsupported product

Latest associated event: ID 100564:

First occurrence: 2012-09-27 03:51:48,599

Last change: 2012-10-23 16:48:10,088

Cleared: N/A

Description: Controller (sc='00:03:52:09:66:5E') is an unsupported product.

Probable cause:

Recommended action:

Acknowledged:

State: Active

Annotation:

Cancel Save

Timestamp

Date and time that the alarm occurred.

Ack

Indicates if the alarm has been acknowledged. An acknowledged alarm is not cleared. The acknowledgment serves as an indicator that an administrator is aware of the alarm.

Note

A yellow note icon indicates the presence of an annotation. Hover over the icon to see the contents of the annotation. To edit an annotation, open the Alarm details page.

State

Alarm state (active or cleared). To clear an alarm, select the description field, or select the **Clear** action and select **Apply**. Some alarms are automatically cleared when the condition that caused it is resolved. An already active alarm will not be raised again for the same source.

Button

Export

Click this button to export all alarms that appear in the list to a CSV (comma-separated values) file for use in other applications.

Configuring SNMP notifications for events and alarms

Notifications can be set via SNMP for specific events and alarms as follows:

1. Select **Controller >> Management > SNMP**. The SNMP agent configuration page opens.

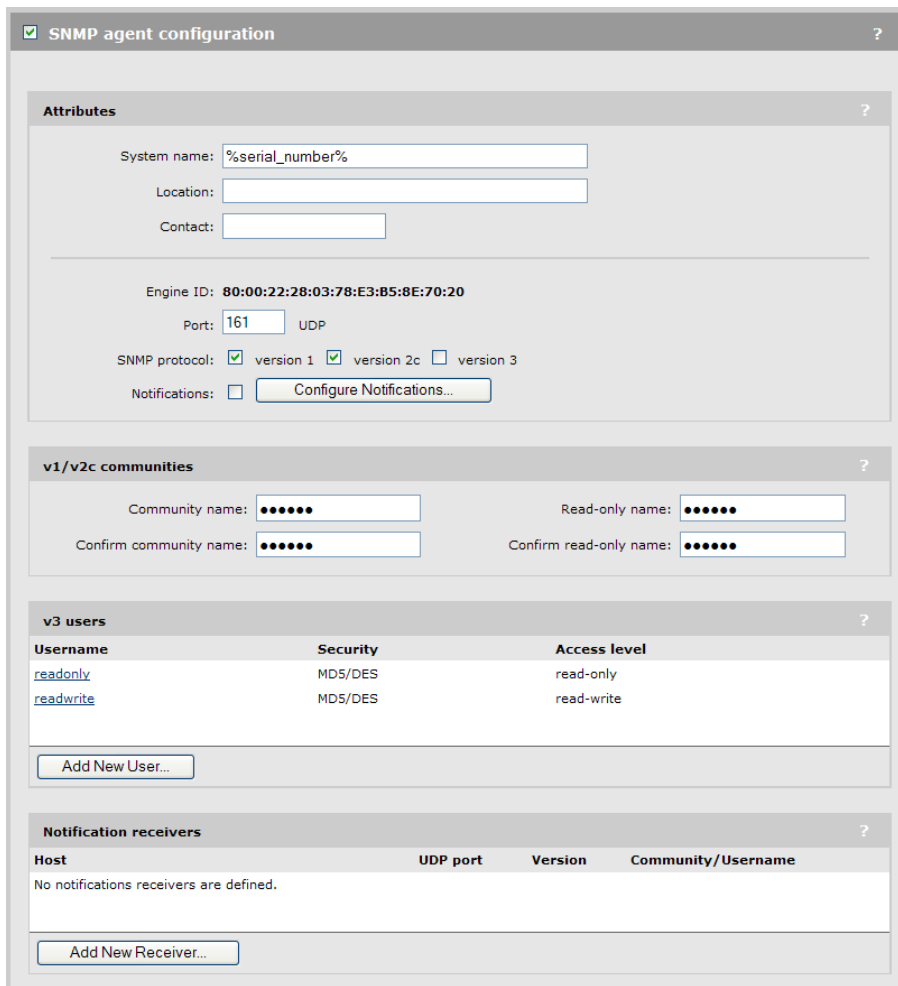

The screenshot shows the 'SNMP agent configuration' page. At the top, there is a checked checkbox for 'SNMP agent configuration'. Below this is the 'Attributes' section with fields for 'System name' (containing '%serial_number%'), 'Location', and 'Contact'. The 'Engine ID' is '80:00:22:28:03:78:E3:B5:8E:70:20'. The 'Port' is '161' and the protocol is 'UDP'. Under 'SNMP protocol', 'version 1' and 'version 2c' are checked, while 'version 3' is unchecked. There is a 'Notifications' checkbox which is unchecked, and a 'Configure Notifications...' button. Below the attributes is the 'v1/v2c communities' section with fields for 'Community name', 'Read-only name', 'Confirm community name', and 'Confirm read-only name'. The next section is 'v3 users', which contains a table:

Username	Security	Access level
readonly	MDS/DES	read-only
readwrite	MDS/DES	read-write

Below the table is an 'Add New User...' button. The final section is 'Notification receivers', which is currently empty with the text 'No notifications receivers are defined.' and an 'Add New Receiver...' button.

2. Select the **SNMP agent configuration** checkbox and then select **Save**.
3. Under **Attributes**, select the **Notifications** checkbox.
4. Select **Configure Notifications**. The SNMP notification configuration page opens.

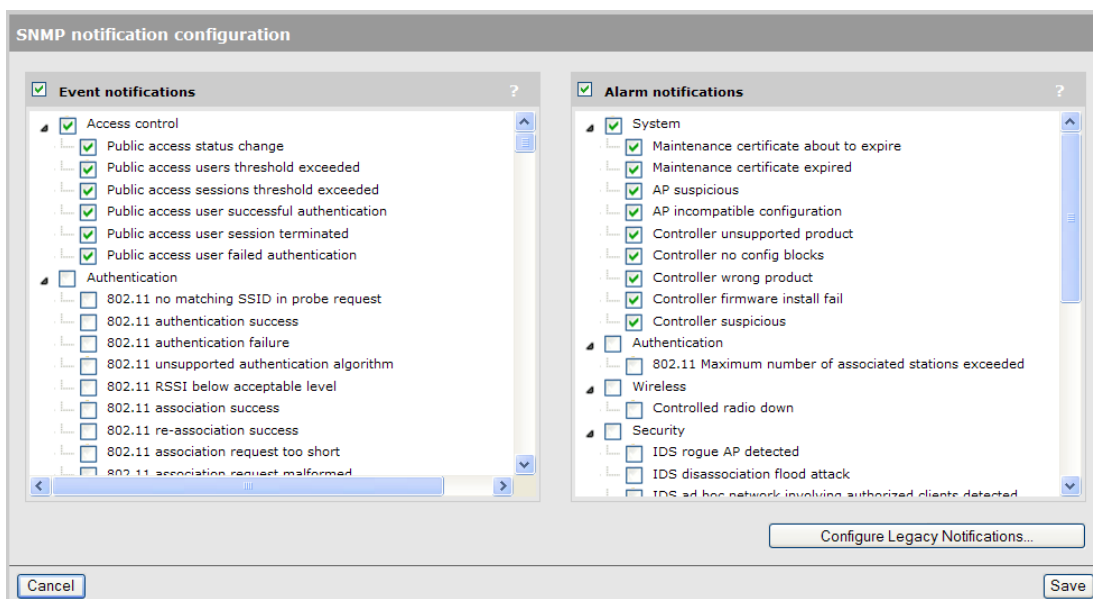

The screenshot shows the 'SNMP notification configuration' page. It has two main sections: 'Event notifications' and 'Alarm notifications'. Both sections have a checked checkbox. The 'Event notifications' section is expanded to show a list of events with checkboxes: 'Access control' (checked), 'Public access status change' (checked), 'Public access users threshold exceeded' (checked), 'Public access sessions threshold exceeded' (checked), 'Public access user successful authentication' (checked), 'Public access user session terminated' (checked), 'Public access user failed authentication' (checked), 'Authentication' (unchecked), '802.11 no matching SSID in probe request' (unchecked), '802.11 authentication success' (unchecked), '802.11 authentication failure' (unchecked), '802.11 unsupported authentication algorithm' (unchecked), '802.11 RSSI below acceptable level' (unchecked), '802.11 association success' (unchecked), '802.11 re-association success' (unchecked), '802.11 association request too short' (unchecked), and '802.11 association request malformed' (unchecked). The 'Alarm notifications' section is also expanded to show a list of alarms with checkboxes: 'System' (checked), 'Maintenance certificate about to expire' (checked), 'Maintenance certificate expired' (checked), 'AP suspicious' (checked), 'AP incompatible configuration' (checked), 'Controller unsupported product' (checked), 'Controller no config blocks' (checked), 'Controller wrong product' (checked), 'Controller firmware install fail' (checked), 'Controller suspicious' (checked), 'Authentication' (unchecked), '802.11 Maximum number of associated stations exceeded' (unchecked), 'Wireless' (unchecked), 'Controlled radio down' (unchecked), 'Security' (unchecked), 'IDS rogue AP detected' (unchecked), 'IDS disassociation flood attack' (unchecked), and 'IDS ad hoc network involving authorized clients detected' (unchecked). At the bottom, there are 'Cancel' and 'Save' buttons, and a 'Configure Legacy Notifications...' button.

5. Enable **Event notifications** and/or **Alarm notifications**, and select the notifications that you want to send for each.
6. Select **Save**. You are returned to the SNMP agent configuration page.
7. In the **Notifications receivers** box, select **Add New Receiver**. The Add/Edit SNMP notifications receiver page opens.

The screenshot shows a web-based configuration window titled "Add/Edit SNMP notifications receiver". Inside the window is a smaller box titled "Receiver settings" with a help icon (?). The settings box contains the following fields:

- Host: [Empty text input field]
- UDP port: [Text input field containing "162"]
- Version: [Dropdown menu showing "Version 2c"]
- Community: [Empty text input field]

At the bottom of the main window, there are two buttons: "Cancel" on the left and "Save" on the right.

8. Define the settings for the receiver as follows:
 - **Host:** Specify the domain name or IP address of the SNMP notifications receiver to which the controller will send notifications.
 - **UDP port:** Specify the port on which notifications will be sent.
 - **SNMP version:** Select the SNMP version (v1, v2c, v3) for this receiver.
 - **Community:** For SNMP v1 and v2c, specify the SNMP community name of the receiver. For SNMP v3, select the SNMP v3 username of the receiver.
9. Select **Save**.

12 Working with VLANs

Key concepts

The controller provides a robust and flexible virtual local area network (VLAN) implementation that supports a wide variety of scenarios.

Up to 80 VLAN definitions can be created on the controller. VLAN ranges are supported, enabling a single definition to span a range of VLAN IDs.

The following controller features are supported on a VLAN:

- Network address translation (*However, static NAT mappings are not supported.*)
- Management tool access
- SNMP access
- SOAP access
- VPN traffic
- L3 mobility
- AP discovery

VLAN usage

VLANs can be used in a number of different ways to affect traffic routing on a controller and its APs. The following is a list of the most common VLAN uses:

- **Controller VSC ingress:** VLANs can be used to determine how incoming traffic is mapped to a VSC on a controller. Assigning a VLAN range enables a single VSC to handle incoming traffic on multiple VLANs. See [“VSC ingress mapping” \(page 122\)](#).
- **Controller VSC egress:** VLANs can be used to control how traffic is forwarded onto the wired network by a VSC on the controller. Traffic can be sent to the LAN port or Internet port, either untagged (no VLAN), tagged with a specific VLAN ID, or distributed across a range of VLAN IDs (using a round-robin mechanism). See [“VSC egress mapping” \(page 123\)](#).
- **VSC binding:** When an AP group is bound to a VSC, an egress VLAN can be specified. This egress is used in several different ways to route traffic depending on the features that are active on the VSC. For example, when Mobility traffic manager is active, this VLAN becomes the users home network. See [“Binding VSCs to groups” \(page 163\)](#).
- **Switch port VLANs:** The switch ports on the HP 517 or MSM317 can be bound to a specific VLAN. See the HP 517 802.11ac Unified Walljack Configuration Guide and the *MSM317 Access Device Installation and Configuration Guide*.
- **User account profile VLAN:** A VLAN can be assigned in a user account profile, enabling you to configure VLAN usage for groups of users ([“Defining account profiles” \(page 357\)](#)).
- **VLAN assignment via RADIUS attributes:** A VLAN can be assigned in a users RADIUS account, enabling you to customize VLANs on a per-user basis. For example, when Mobility traffic manager support is enabled on a VSC, RADIUS VLAN attributes can be used to define a users home network. See [“User-assigned VLANs” \(page 221\)](#).
- **Discovery VLAN:** APs can be provisioned to discover controllers on a specific VLAN. See [“Provisioning APs” \(page 171\)](#).
- **VLANs on a trunk:** On the MSM720 VLANs can be assigned to dynamic or static trunks. See [“Port trunking” \(page 70\)](#).

Defining a VLAN

Defining a VLAN on a controller port

Define a VLAN on a controller port as follows:

1. Define a network profile with the required VLAN as described under “To define a new network profile” (page 33) This example uses a new network profile called **Guest**, assigned to **VLAN 100**.
2. Select **Controller >> Network > VLANs**.

On the MSM720

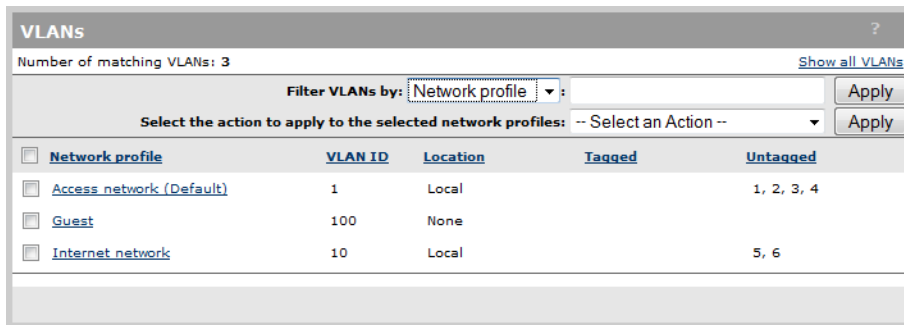

On all other controllers

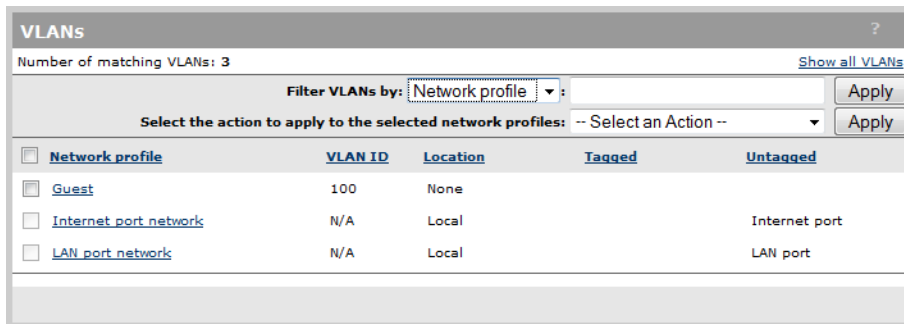

3. Select the network profile you defined in step 1 (Guest). This opens the Add/Edit VLAN mapping page.

On the MSM720

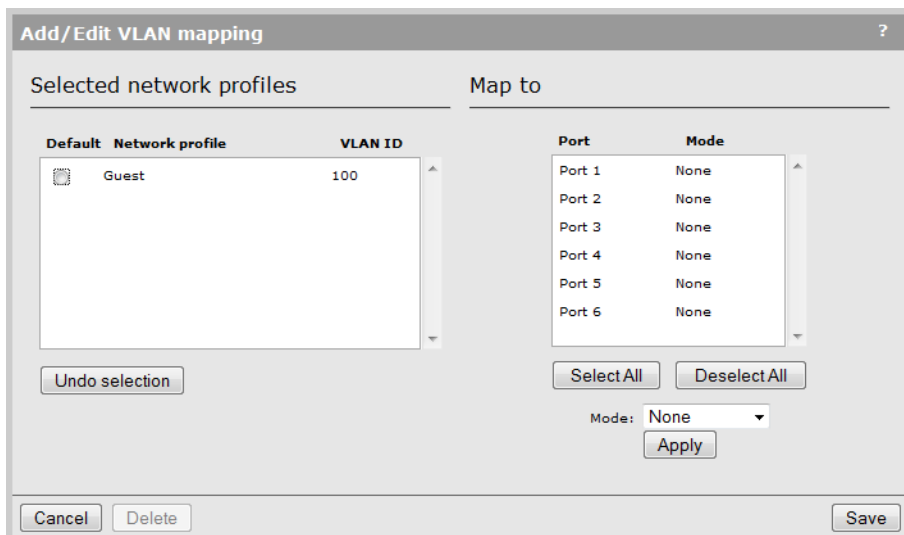

On all other controllers

Network profile	VLAN ID
Guest	100

Map to: Internet port

4. Under **Map to**, select the port to which the VLAN will be bound. On the MSM720, you can select multiple ports or a trunk (Only static trunks appear in the list, dynamic trunks are automatically mapped to the default VLAN).
5. On the MSM720, select one of the following for **Mode** and then select **Apply**:
 - **None**: No VLAN is assigned to the port.
 - **Tagged**: Traffic on the port is sent/received using the VLAN tag defined for the selected network profile(s).
 - **Untagged**: Traffic on the port is sent/received untagged. However, if a VLAN is defined for the selected network profile(s), it is used internally within the controller.
6. Select **Save**.

Assigning VLANs to controlled APs

VLANs can also be assigned to ports on controlled APs at one of the three following levels:

- Base group level by selecting **Controlled APs >> Configuration > VLANs**.
- Group level by selecting **Controlled APs > [group] >> Configuration > VLANs**.
- AP level by selecting **Controlled APs > [group] > [AP] >> Configuration > VLANs**.

In all cases, the VLANs page presents the same options that are available at the controller level (See [“Defining a VLAN on a controller port”](#) (page 219) for details.).

For example, if you select **Controlled APs >> Configuration > VLANs**, select two ports, select **Add New Mapping**, and then select **Apply**.

<input type="checkbox"/>	Network profile	VLAN ID	Location	Tagged	Untagged
<input type="checkbox"/>	Internet port network	N/A	None		
<input type="checkbox"/>	LAN port network	N/A	None		
<input checked="" type="checkbox"/>	Guest VLAN	11	None		
<input checked="" type="checkbox"/>	Employee VLAN	22	None		

The Add/Edit VLAN mapping page shows both ports and enables you to map them both to a port on the AP.

Network profile	VLAN
Guest VLAN	11
Employee VLAN	22

Map to

Port: Port 1

User-assigned VLANs

VLANs can be assigned on a per-user basis using attributes defined in a users RADIUS account, or via VLAN definitions in a local user account profile. These user-assigned VLANs are also called dynamic VLANs because they are applied dynamically after a user is authenticated and override the static definitions on VSCs or VSC bindings.

For a complete description on how VLANs affect traffic flow, see [“Traffic flow for wireless users” \(page 221\)](#).

VLAN assignment via RADIUS

To define a VLAN in a users RADIUS account, you need to set the RADIUS attributes Tunnel-Medium-Type, Tunnel-Private-Group-ID, and Tunnel-Type. The Tunnel-Private-Group-ID attribute should be set to the name of the VLAN. A VLAN number can also be specified, but this not recommended.

See the *Access Accept* section under [“User attribute definitions” \(page 448\)](#) for more information on these attributes.

VLAN assignment via the local user accounts

VLANs can be assigned on a per-user basis by configuring a user account profile with the appropriate VLAN number. See [“Defining a user account” \(page 355\)](#) and [“Defining account profiles” \(page 357\)](#).

Traffic flow for wireless users

Due to the large number of features that can make use of VLANs, and the way in which these features interact, VLAN settings at different points in the configuration can affect traffic flow for wireless users in different ways. The following tables provide an overview of all possible configuration settings and how they affect data flow. The tables are organized according to the type of VSC that is being bound to an AP.

NOTE: On access-controlled VSCs, user-assigned VLANs only override the egress VLAN assigned once a user has been authenticated.

Binding to a VSC that has *Wireless mobility* disabled

VSC type	Egress network in VSC binding	Client data tunnel	User-assigned VLAN is not assigned via RADIUS or local user accounts	User-assigned VLAN is assigned via RADIUS or local user accounts		
				User-assigned VLAN exists on AP or controller	User-assigned VLAN does not exist on AP or controller	
					VLAN ID	VLAN name
Access-controlled	Defined	Active	<p>The Egress network setting in the VSC binding is ignored.</p> <p>Traffic is sent to the controller in the client data tunnel. It exits the controller on the egress mapping defined on the appropriate VSC.</p>	<p>The Egress network setting in the VSC binding is ignored.</p> <p>Traffic is sent to the controller in the client data tunnel. It exits the controller on the user-assigned VLAN, which overrides any egress mapping defined on the controllers VSC.</p>	User traffic will never reach its destination because the user-assigned VLAN does not match any VLAN IDs defined on the AP or controller.	<p>The Egress network setting in the VSC binding is ignored.</p> <p>Traffic is sent to the controller in the client data tunnel. It exits the controller on the egress mapping defined on the appropriate VSC.</p>
		Disabled	<p>Traffic is sent on the AP Ethernet port tagged with the VLAN specified by the Egress network in the VSC binding.</p> <p>The Egress network VLAN must match the ingress VLAN on the bound VSC (or be altered by a switch between the AP and the controller to do so) otherwise traffic from the AP will not reach the controller.</p> <p>Traffic exits the controller on the egress mapping defined on the appropriate VSC.</p>	<p>Traffic is sent on the AP Ethernet port tagged with the VLAN specified by the Egress network in the VSC binding.</p> <p>The Egress network VLAN must match the ingress VLAN on the bound VSC (or be altered by a switch between the AP and the controller to do so) otherwise traffic from the AP will not reach the controller.</p> <p>Traffic exits the controller on the user-assigned VLAN, which overrides any egress mapping defined on the controllers VSC.</p>		<p>Traffic is sent on the AP Ethernet port tagged with the VLAN specified by the Egress network in the VSC binding.</p> <p>The Egress network VLAN must match the ingress VLAN on the bound VSC (or be altered by a switch between the AP and the controller to do so) otherwise traffic from the AP will not reach the controller.</p> <p>Traffic exits the controller on the egress mapping defined on the appropriate VSC.</p>

VSC type	Egress network in VSC binding	Client data tunnel	User-assigned VLAN is not assigned via RADIUS or local user accounts	User-assigned VLAN is assigned via RADIUS or local user accounts		
				User-assigned VLAN exists on AP or controller	User-assigned VLAN does not exist on AP or controller	
					VLAN ID	VLAN name
	Not defined	Active	Traffic is sent to the controller in the client data tunnel and is mapped to a VSC on the controller by SSID. It exits the controller on the egress mapping defined on the appropriate VSC.	Traffic is sent to the controller in the client data tunnel and is mapped to a VSC on the controller by SSID. It exits the controller on the user-assigned VLAN, which overrides any egress mapping defined on the controllers VSC.		Traffic is sent to the controller in the client data tunnel and is mapped to a VSC on the controller by SSID. It exits the controller on the egress mapping defined on the appropriate VSC.
		Disabled	Traffic is sent to the controller untagged via the AP Ethernet port and is mapped to a VSC on the controller by SSID. It exits the controller on the egress mapping defined on the appropriate VSC.	Traffic is sent to the controller untagged via the AP Ethernet port and is mapped to a VSC on the controller by SSID. It exits the controller on the user-assigned VLAN, which overrides any egress mapping defined on the controllers VSC.		Traffic is sent to the controller untagged via the AP Ethernet port and is mapped to a VSC on the controller by SSID. It exits the controller on the egress mapping defined on the appropriate VSC.
Non access controlled	Defined	Does not apply.	Traffic is sent on the AP Ethernet port tagged with the VLAN specified by the Egress network in the VSC binding.	The Egress network setting in the VSC binding is ignored. Traffic is sent on the AP Ethernet port tagged with the user-assigned VLAN.		The user is disconnected.
	Not defined	Does not apply.	Traffic is sent on the AP Ethernet port untagged.	Traffic is sent on the AP Ethernet port tagged with the user-assigned VLAN.		

Binding to a VSC that has *Wireless mobility* and *Mobility traffic manager* enabled

Egress network in VSC binding	User-assigned VLAN is not assigned via RADIUS or local user accounts	User-assigned VLAN is assigned via RADIUS or local user account			
		User-assigned VLAN exists in the mobility domain		User-assigned VLAN does not exist in the mobility domain	
		VLAN ID	VLAN name	VLAN ID	VLAN name
Defined	Assign the Egress network defined in the VSC binding as the users home network.	<p>The Egress network setting in the VSC binding is ignored.</p> <p>The first network that is found with the same VLAN ID specified in the user-assigned VLAN is assigned as the users home network.</p>	<p>The Egress network setting in the VSC binding is ignored. The VLAN name contained in the user-assigned VLAN is assigned as the users home network.</p>	Use the fallback setting defined by the VSC option If no matching network is assigned (either block user or consider the user at home).	The AP blocks the user from accessing the network.
Not defined	Use the fallback setting defined by the VSC option If no matching network is assigned (either block user or consider the user at home).	<p>The first network that is found with the same VLAN ID specified in the user-assigned VLAN, is assigned as the users home network.</p>	<p>The VLAN name contained in the user-assigned VLAN is assigned as the users home network.</p>		

Binding to a VSC that has *Wireless mobility* and *Subnet-based mobility* enabled

Egress network in VSC binding	User-assigned VLAN is not assigned via RADIUS or local user accounts	User-assigned VLAN is assigned via RADIUS or local user account		
		User-assigned VLAN exists in the mobility domain	User-assigned VLAN does not exist in the mobility domain	
			VLAN ID	VLAN name
Defined.	<p>The IP address of the user is compared against the list of home subnets defined for the AP to determine if the user is at home or roaming.</p> <p>If the user is at home, traffic is sent on the AP Ethernet port tagged with the VLAN specified by the Egress network in the VSC binding.</p> <p>If the user is roaming, traffic is tunneled to the users home subnet within the mobility domain, where it egresses tagged with the VLAN specified by the Egress network in the VSC binding.</p>	<p>The IP address of the user and the VLAN ID are compared against the list of home subnets defined for the AP to determine if the user is at home or roaming. (Both the IP and VLAN must match the home subnet.)</p> <p>If the user is at home, traffic is sent on the AP Ethernet port tagged with the user-assigned VLAN.</p> <p>The Egress network in the VSC binding is ignored.</p> <p>If the user is roaming, traffic is tunneled to the users home network within the mobility domain, where it will egress tagged with the user-assigned VLAN.</p>	<p>The Egress network setting in the VSC binding is ignored.</p> <p>User is considered to be at home and traffic is sent on the AP's Ethernet port tagged with the user-assigned VLAN.</p>	The user is disconnected.
Not defined.	<p>The IP address of the user is compared to the IP address of the APs Ethernet port to determine if the user is at home or roaming.</p> <p>If the user is at home, traffic is sent on the AP Ethernet port untagged.</p> <p>If the user is roaming, traffic is tunneled to the users home network within the mobility domain, where it will egress untagged.</p>	<p>The IP address of the user and the VLAN ID are compared against the list of home subnets defined for the AP to determine if the user is at home or roaming. (Both the IP and VLAN must match the home subnet.)</p> <p>If the user is at home, traffic is sent on the AP Ethernet port tagged with the user-assigned VLAN.</p> <p>If the user is roaming, traffic is tunneled to the users home network within the mobility domain, where it will egress tagged with the user-assigned VLAN.</p>	User is considered to be at home and traffic is sent on the AP's Ethernet port tagged with the user-assigned VLAN.	

Terms used in the tables

- **Egress network in VSC binding:** This column refers to the Egress network option that can be configured when an AP group is bound to a VSC. The egress network can be used to assign a specific VLAN. How this VLAN is applied to the routing of traffic is illustrated by the tables.
- **Client data tunnel:** The client data tunnel can be used by an AP to transport wireless user traffic to the controller. The client data tunnel is automatically used if the network path between an AP and the controller traverses a router. In the case where the AP is on the same layer 2 subnet as the controller, the client data tunnel is not automatically used, but can be manually activated by enabling the **Always tunnel client traffic option** on the VSC configuration page. Available on access-controlled VSCs only.
- **User-assigned VLAN is not assigned via RADIUS or local user accounts:** This column indicates what happens when a user-assigned VLAN attribute is not assigned via RADIUS or via a local user account or account profile.
- **User-assigned VLAN exists in the mobility domain:** This column indicates what happens when a user-assigned VLAN attribute is assigned via RADIUS or via a local user account or account profile, and if that VLAN (or network) is defined within the mobility domain. In some cases the behavior is different if the VLAN attribute specifies a network profile name or an actual VLAN ID (number).
- **User-assigned VLAN does not exist in the mobility domain:** This column indicates what happens when a user-assigned VLAN attribute is assigned via RADIUS or via a local user account or account profile, and if that VLAN (or network) is not defined within the mobility domain. In some cases the behavior is different if the VLAN attribute specifies a network profile name or an actual VLAN ID (number).

Traffic flow examples

The following examples illustrate some typical VLAN scenarios using the information from the tables in section [“Traffic flow for wireless users”](#) (page 221).

To help cross-reference with the tables, all configuration settings are shown using the headings and descriptions from the tables.

Example 1 Overriding the VSC egress on a controller with a user-assigned VLAN

This example illustrates how a user-assigned VLAN can override a VSC egress setting on the controller.

Configuration summary

- **APs are bound to a VSC that has Wireless mobility disabled**
- **VSC type:** Access controlled
- **Egress network in VSC binding:** Defined VLAN = 10
- **Client data tunnel:** Disabled
- **User-assigned VLAN is assigned via RADIUS or local user accounts:** Assigned VLAN = 30
- **User-assigned VLAN exists on AP or controller:** VLAN 30 is defined on the controller Internet port
- **Result:** Traffic is sent on the APs Ethernet port tagged with the VLAN specified by the Egress network in the VSC binding. The Egress network VLAN must match the ingress VLAN on the bound VSC (or be altered by a switch between the AP and the controller to do so) otherwise traffic from the AP will not reach the controller. Because there is a non-access-controlled VSC, the user-assigned VLAN applies only on the controller. Therefore, user traffic exits the controller on the user-assigned VLAN, which overrides the VSC egress mapping (no VLAN) defined for the VSC Guest.

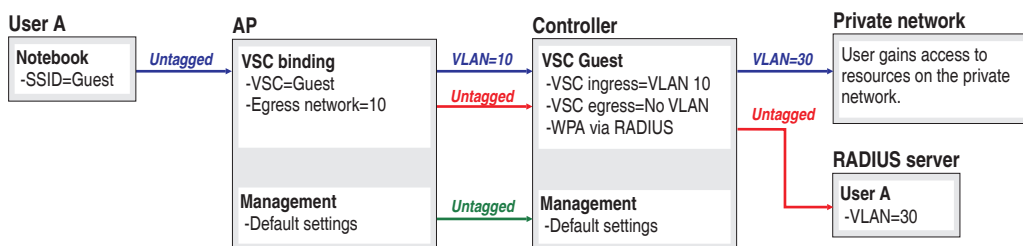
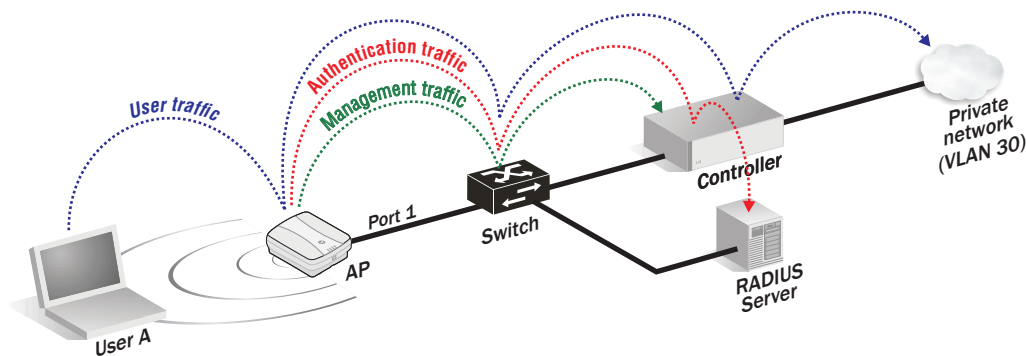

In this example, the egress network in the APs VSC binding is set to 10. The AP sends user wireless traffic to the controller on VLAN 10. This traffic is picked up by the controllers VSC with ingress set to 10.

A VLAN of 30 is assigned to the user via their RADIUS account, which overrides the egress setting for the VSC on the controller. As a result, the users traffic exits the controller on VLAN 30, which is mapped to the controller Internet port.

Example 2 Overriding the egress network in a VSC binding with a user-assigned VLAN

In this scenario, a non-access-controlled VSC is used to illustrate how a user-assigned VLAN can override the egress network defined for a VSC binding.

Configuration summary

- **APs are bound to a VSC that has Wireless mobility disabled**
- **VSC type:** Non-access-controlled
- **Egress network in VSC binding:** Defined VLAN = 10
- **Client data tunnel:** Disabled
- **User-assigned VLAN is assigned via RADIUS or local user accounts:** No VLAN is assigned to User A. A VLAN of 20 is assigned to User B.
- **User-assigned VLAN exists on AP or controller:** Not applicable

Result:

- **User A:** The Egress network setting in the VSC binding is used. Traffic is sent on the APs Ethernet port tagged with VLAN 10.
- **User B:** The Egress network setting in the VSC binding is ignored. Traffic is sent on the APs Ethernet port tagged with the user-assigned VLAN (20).

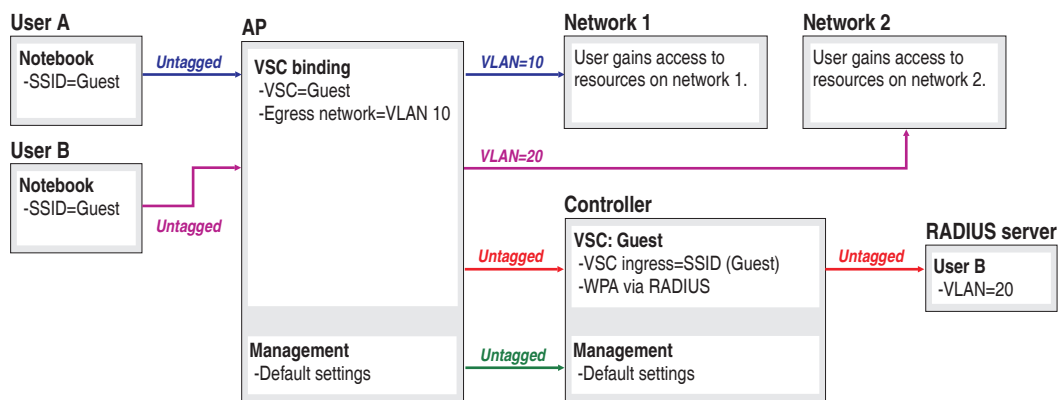
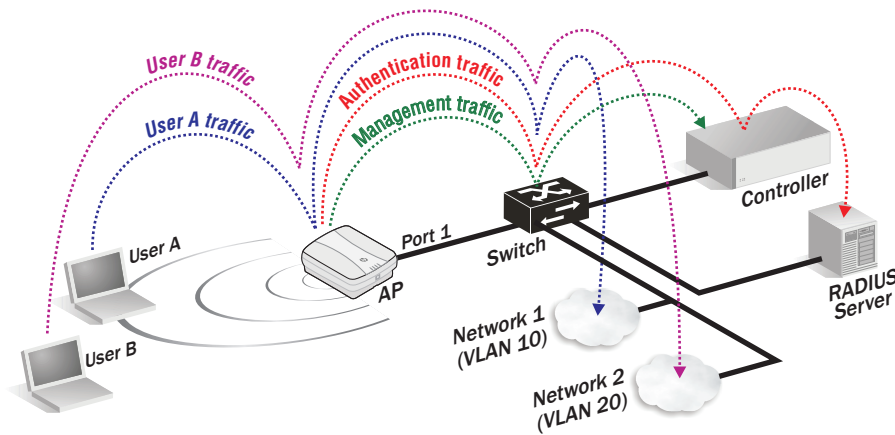

In this example, the AP is bound to an non-access-controlled VSC. User A illustrates default behavior. User B illustrates how to override the default behavior with an user-assigned VLAN.

- **User A** does not have a VLAN assigned via RADIUS, so traffic from this user exits the APs Ethernet port on the egress network (VLAN 10) defined in the VSC binding, allowing it to reach the network 1.

- **User B** has a VLAN of 20 assigned via their RADIUS account, which **overrides** the egress network defined in the VSC binding. As a result, traffic from User B is sent on the APs Ethernet port tagged with VLAN 30, allowing it to reach the network 2.
-

13 Managing Bonjour traffic

Overview

Bonjour is a zero configuration networking protocol that enables devices to automatically publish and discover IP-based services on a local area network. However, because Bonjour was designed for small, unmanaged networks, it creates several challenges for the enterprise network administrator:

- Bonjour is based on Multicast DNS (mDNS). Heavy use of multicast greatly affects throughput on 802.11 wireless networks because multicasts are always sent at the lowest configured data rate on the radio.
- Bonjour was designed to operate on small, layer 2 networks, and it was never intended to scale beyond a few dozen nodes (without the use of the more advanced version known as Wide-Area Bonjour). It uses link-local IP multicasts, which limit a client to discovering services on a single subnet. This can be problematic in enterprise networks with services on more than one subnet.
- Bonjour was designed to operate in an environment where all nodes are cooperating and are trusted. It assumes that all nodes on a network should have access to all services. Since it makes no attempt at security, a malicious node can easily disrupt and/or hijack services.

The MSM7xx controller has been designed to address these issues. It provides the following features:

- **Bonjour gateway:** This feature enables Bonjour clients to discover Bonjour services across layer 3 subnet boundaries. It works by relaying Bonjour traffic between interfaces connected to the controller. The gateway is transparent to the Bonjour protocol and does not modify any packet data. The gateway is supported on standalone controllers and controller teams.
- **Bonjour traffic management:** This feature reduces wireless network congestion caused by Bonjour's heavy reliance on mDNS multicasts. When enabled, only interested wireless devices receive Bonjour service announcements, and the use of mDNS multicasts is limited to finding interested stations.
- **Bonjour traffic filtering:** Network administrators can define filters that control how inbound or outbound Bonjour announcements are handled. Each filter is defined in a filter profile, which can contain up to 15 rules for matching Bonjour announcements. Profiles can be applied at the VSC, AP, or user level as required. Filters enable a network administrator to control the ability of clients to discover only the services that they are allowed to use.

Supported products

Bonjour features are available on the following products:

- HP MSM720 (Requires the Premium Mobility Controller license.)
- HP MSM760 (Requires the Premium Mobility Controller license.)
- HP MSM765 zl
- HP MSM775 zl
- HP MSM410
- HP 425
- HP MSM430
- HP MSM460
- HP MSM466/466-R
- HP 517

All Bonjour features are supported when controller teaming is active. (Bonjour features are configured on the team manager only.)

Limitations

Bonjour features are not supported in the following cases:

- Roaming users that are making use of mobility traffic manager (MTM)
- On APs that are connected via local mesh links
- When WPA security is enabled on a VSC and it is terminated at the controller
- Over any PPP tunnel created by the following features: PPTP client, PPPoE, PPTP server
- Over any GRE, L2TP, or IPSec tunnel
- Over a static NAT mapping
- For access-controlled wired clients
- For client stations connected to a third-party AP
- On APs running in autonomous mode

Important

Take note of the following:

- When more than one controller is installed on a network, Bonjour gateway must be configured on each controller so that there is only one forwarding path between any two networks or VLANs. Otherwise, an mDNS loop can occur resulting in excessive amounts of network traffic.
- On a controller team, Bonjour gateway is configured only on the team manager.
- Bonjour is a service discovery protocol, not a service access protocol. It can be used to restrict service discovery, but if a network administrator wants to restrict service access, they must use some other means.
- Just because a client can discover a service using Bonjour does not mean that the client will be able to reach that service. It is up to the network administrator to configure the network to allow clients to reach the services that they should have access to.
- When both Bonjour gateway and traffic management are enabled, all Bonjour IPv6 traffic is dropped by the APs.

Bonjour gateway

The Bonjour gateway feature forwards Bonjour traffic between interfaces defined on the controller. The gateway is transparent to the Bonjour protocol. It only modifies the IP header fields as required to have a valid IP packet on the new subnet. Packet contents are not changed. Bonjour gateway functions differently for client stations connected to access-controlled and non-access controlled VSCs.

NOTE:

- The gateway does not filter Bonjour traffic. To do this, you must define Bonjour filter profiles and assign them to a VSC, AP, or user. See [“Bonjour traffic filtering” \(page 238\)](#).
 - The gateway can only function on interfaces and VLANs that have a valid IP address.
-

Access-controlled VSCs

The following diagrams shows how Bonjour traffic is handled when using access-controlled VSCs.

Access controlled VSC with no VLANs

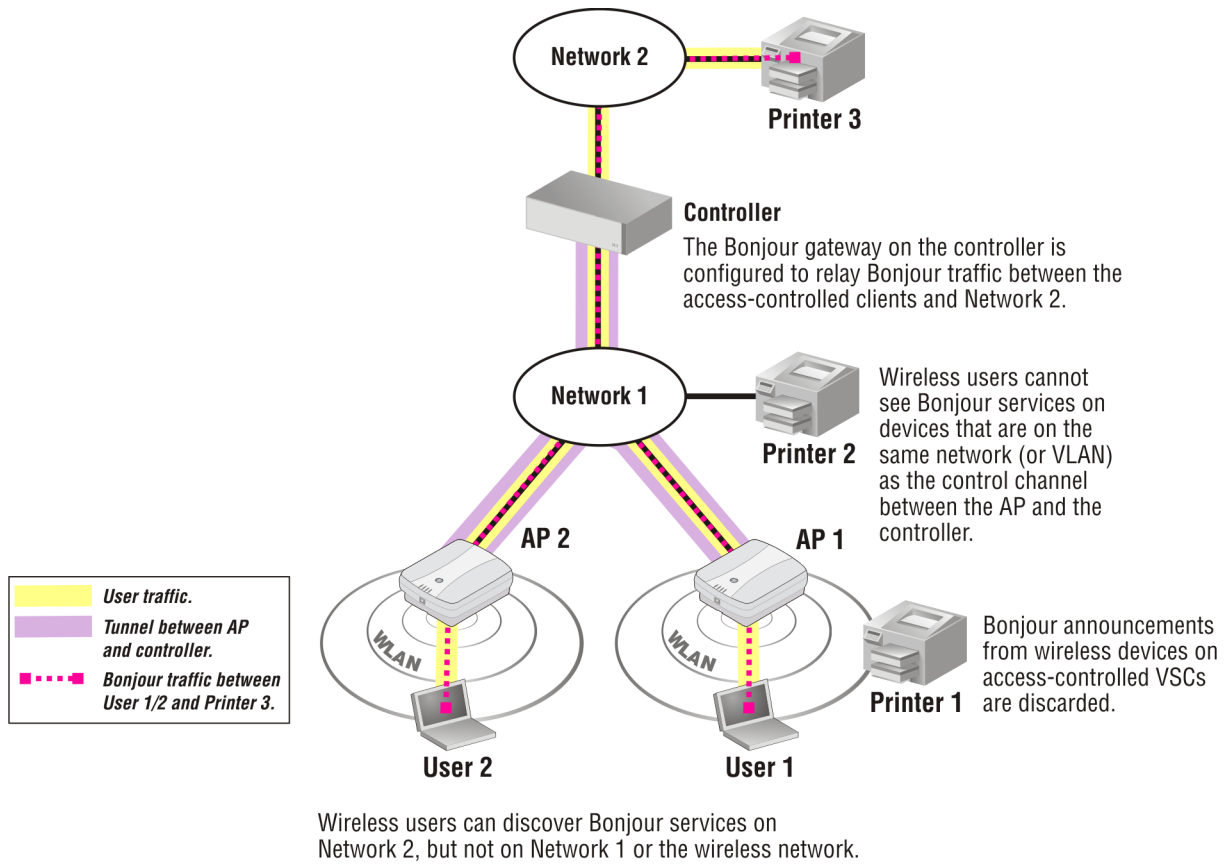

Access controlled VSC with VLANs

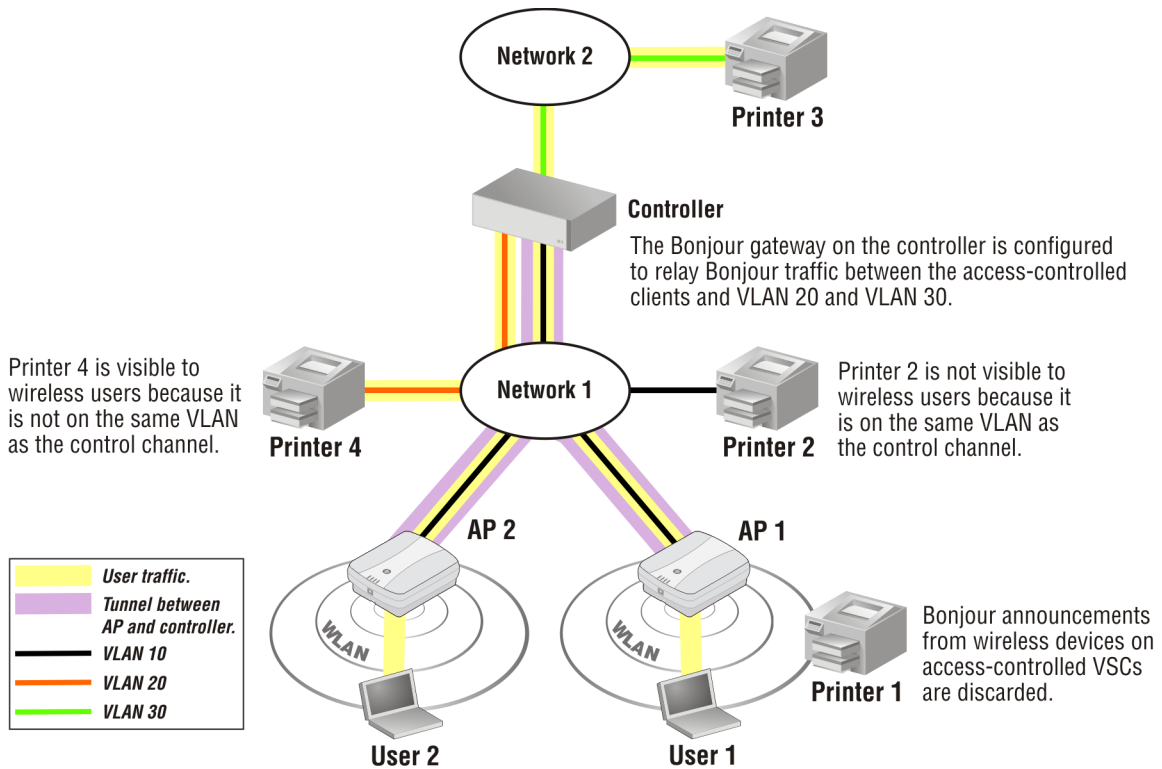

NOTE:

- Bonjour announcements originating from wireless clients on access-controlled VSCs are discarded. This means that it is not possible to have an access-controlled wireless client advertise services via Bonjour.
- If you assign a VLAN to a VSC egress mapping, access-controlled clients can only reach Bonjour services that are on the same VLAN (as long as it is not the same VLAN used for the control channel between the AP and controller).
- Wireless clients cannot discover Bonjour services on the subnet used by an AP to establish its control channel with a controller. Bonjour service announcements on this subnet are discarded by the AP and controller.
- When both Bonjour gateway and traffic management are enabled, all Bonjour IPv6 traffic is dropped by the APs.

Non-access-controlled VSCs

The following diagram shows how Bonjour traffic is handled when using non-access-controlled VSCs.

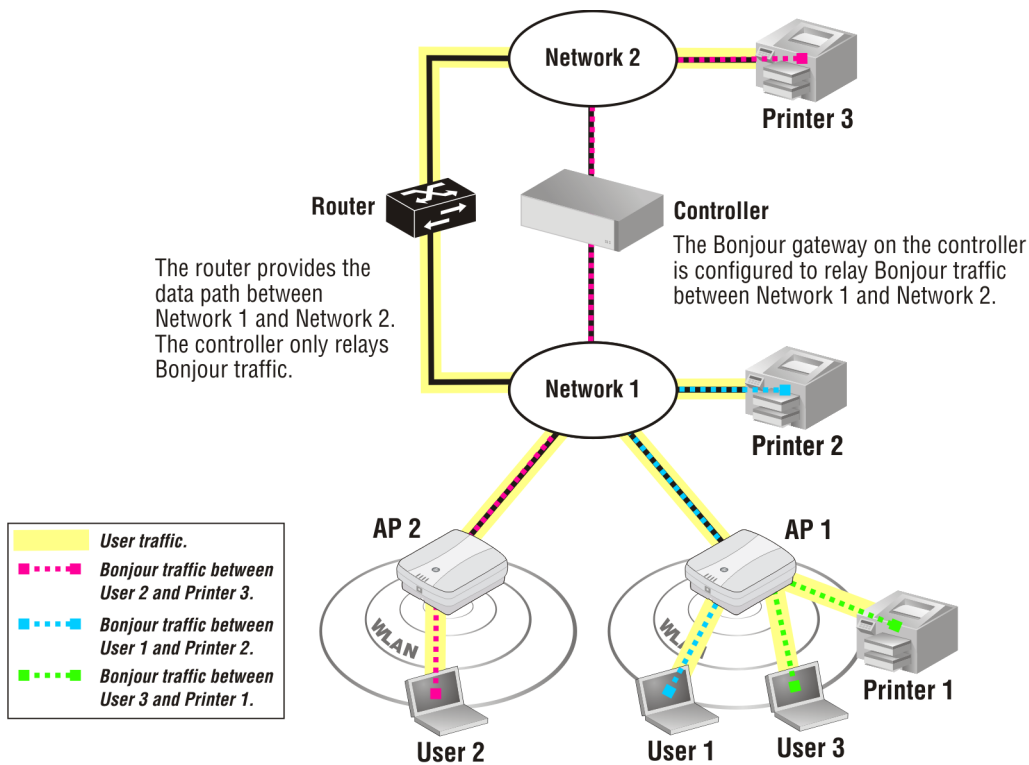

User 1 and User 2 can see the services offered by Printer 1, Printer 2, and Printer 3.

NOTE:

- Since the controller is not in the data path of non-access-controlled wireless clients, an external router must provide the data path to any Bonjour services on another network. Otherwise, wireless clients will see service announcements from devices that they are not able to reach. (The Bonjour gateway on the controller will relay Bonjour traffic between subnets, but it will not relay data traffic from client stations clients. A router needs to be configured to do this (as shown in the previous diagram).
 - Non-access-controlled wireless clients *can* advertise services via Bonjour.
 - Non-access-controlled wireless clients *can* discover Bonjour services on the subnet used by an AP to establish its control channel with a controller.
-

Configuring Bonjour gateway

Do the following to enable and configure Bonjour gateway on a controller:

1. Select **Controller >> Network > Bonjour**. The Bonjour configuration page opens.

Bonjour configuration ?

Gateway ?

Enable Bonjour gateway on the selected interfaces

Available interfaces: Selected interfaces:

Internet network

Traffic management ?

Enable Bonjour traffic management on:

All access-controlled VSCs

All non-access-controlled VSCs on the APs in the group: Default Group [v] [Apply]

(Currently enabled on 0 of 0 APs)

For more AP group configuration options click [here](#).

Traffic filtering ?

Enable Bonjour traffic filtering on:

All access-controlled VSCs and user profiles

All non-access-controlled VSCs on the APs in the group: Default Group [v] [Apply]

(Currently enabled on 0 of 0 APs)

For more AP group configuration options click [here](#).

Manage Bonjour Filter Profiles...

[Save]

2. In the **Gateway** box:
 - Select the checkbox **Enable Bonjour gateway on the selected interfaces**.
 - Assign one or more interfaces to the gateway. The **Available interfaces** list shows all IP interfaces that can be assigned to the gateway. For an IP interface to appear in the list

it must have an IP address assigned to it. The **Selected interfaces** list shows all interfaces on which the Bonjour gateway is enabled.

When working with access-controlled VSCs:

- Assign at least one interface to the **Selected interfaces** list. This is required so that access-controlled clients can reach Bonjour services on another network. Typically, you would assign the **VSC egress mapping** you defined on the VSC page to the **Selected interfaces** list. If you leave the **VSC egress mapping** set to **<Default>** you must assign the **Internet port** (**Internet network** on the MSM720) to the **Selected Interfaces** list.

Note: If you assign a VLAN to a VSC egress mapping, access-controlled clients can only reach Bonjour services that are on the same VLAN (as long as it is not the same VLAN used for the control channel between the AP and controller).

When working with non-access-controlled VSCs:

- Assign at least two interfaces to the **Selected interfaces** list.

3. Select **Save**.

Bonjour traffic management

The traffic management feature reduces wireless network congestion caused by Bonjour's heavy reliance on mDNS multicasts. When enabled, only interested wireless devices receive Bonjour service announcements, and the use of mDNS multicasts is limited to finding interested stations.

Traffic management is performed on the controller for clients connected to access-controlled VSCs, and on the APs for clients connected to non-access-controlled VSCs.

Traffic manager listens for Bonjour traffic with any of the following attributes:

- Queries and responses sent to address 224.0.0.251, UDP port 5353.
- Queries for a name ending with **.local** sent to address 224.0.0.251 on UDP source and destination ports 5353.
- Queries and responses for names that do not end with **.local**. (Traffic filters are not applied to these queries. They cannot be filtered. However, the gateway will relay them.)
- Unicast queries and responses sent to UDP port 5353.

Traffic manager intercepts all multicast announcements from Bonjour devices and stores them. It does not forward them onto the wireless network. Instead, it waits for a matching query from a wireless device. When this occurs, the announcement is forwarded only to that station.

Examples

These examples illustrate how traffic manager and Bonjour gateway can provide users with access to printers at different places within the network, while at the same time limiting multicasts on the wireless networking infrastructure.

When using a non-access-controlled VSC

In this example, all wireless stations are connected to a non-access-controlled VSC. Bonjour gateway is enabled on the controller and configured to relay Bonjour traffic between Network 1 and Network 2. Traffic management is also enabled.

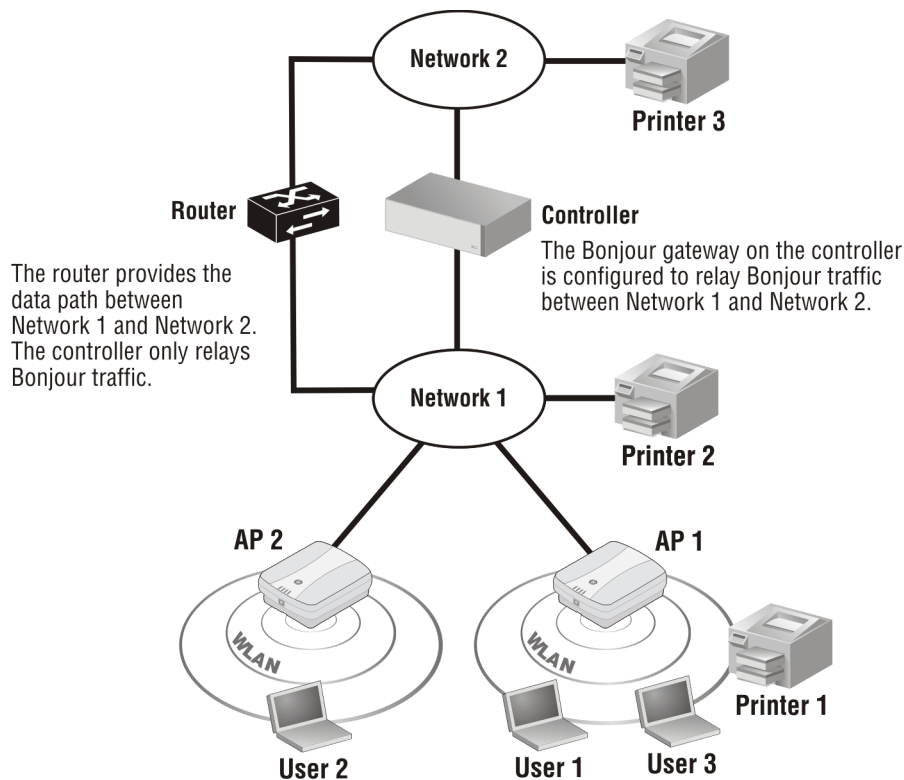

1. User 1 sends a multicast query for a printer.
2. AP 1 receives the query and stores it.
3. AP 1 checks its records for printer announcements. There is one from Printer 1, so AP 1 unicasts the query to Printer 1. It also multicasts the query onto Network 1.
 - Printer 1 receives the query and sends a multicast response.
 - Printer 2 receives the query and sends a multicast response onto Network 1.
 - The controller receives the query. The Bonjour gateway feature on the controller relays the query from Network 1 to Network 2, where Printer 3 receives the query and sends a multicast response. The controller relays the response back to Network 1.
4. AP 1 receives the responses from Printer 1, Printer 2, and Printer 3. The query from User 1 remains active on the AP for seven seconds. All responses that are received within seven seconds are unicast to User 1 by the AP. The AP does not send the responses to any other wireless clients.

When using an access-controlled VSC

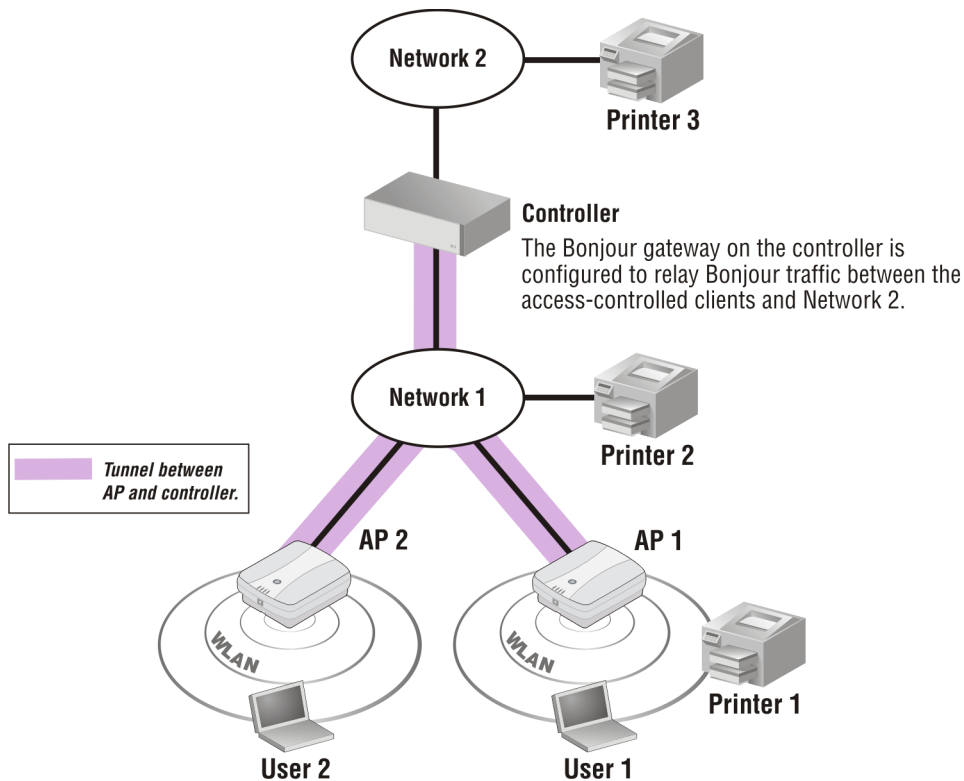

In this example, all wireless stations are connected to an access-controlled VSC. Bonjour gateway is enabled on the controller and configured to relay Bonjour traffic between Network 1 and Network 2. Traffic management is also enabled.

1. User 1 sends a multicast query for a printer.
2. AP 1 forwards the query through the control channel to the controller. It does not multicast the query onto Network 1.
3. The controller receives the query. The Bonjour gateway feature on the controller relays the query to the VSC egress, which in this case is set to Network 2.
4. Printer 3 receives the query and sends a multicast response.
5. The controller sends the response into the control channel to AP 1, where it is forwarded as a unicast to User 1.

(Note: If the VSC egress is configured for **<Default>** then the query would be forwarded onto all interfaces on which Bonjour gateway is enabled. However, the gateway cannot be enabled on the same Network or VLAN on which the control channel is active.)

Configuring traffic management

Do the following to enable and configure traffic management:

1. Select **Controller >> Network > Bonjour**. The Bonjour configuration page opens.

Bonjour configuration ?

Gateway ?

Enable Bonjour gateway on the selected interfaces

Available interfaces: Selected interfaces:

Internet network

Traffic management ?

Enable Bonjour traffic management on:

All access-controlled VSCs

All non-access-controlled VSCs on the APs in the group: Default Group [v] Apply

(Currently enabled on 0 of 0 APs)

For more AP group configuration options click [here](#).

Traffic filtering ?

Enable Bonjour traffic filtering on:

All access-controlled VSCs and user profiles

All non-access-controlled VSCs on the APs in the group: Default Group [v] Apply

(Currently enabled on 0 of 0 APs)

For more AP group configuration options click [here](#).

Manage Bonjour Filter Profiles...

Save

2. Enable and configure the gateway described in the section “[Configuring Bonjour gateway](#)” (page 234).
3. In the **Traffic management** box, enable Bonjour traffic management as follows:
 - **All access-controlled VSCs:** Select this option to enable traffic management on all access-controlled VSCs that are defined on the controller and are bound to any APs. Traffic management cannot be selectively enabled on individual APs or AP groups. It is either on for all access-controlled VSCs or off. (Note that Bonjour announcements originating from wireless clients on access-controlled VSCs are discarded. This means that it is not possible to have an access-controlled wireless client advertise services via Bonjour.)
 - **All non-access-controlled VSCs on the APs in the group:** Select the AP group on which you want to enable traffic management, and then select **Apply**. To enable traffic management on more than one group, select each group in turn and click **Apply**.
If you want to enable traffic management for an individual AP, select **Controlled APs** in the Network Tree, select the AP, and then select **Configuration > Bonjour**.
4. Select **Save**.

Bonjour traffic filtering

Traffic filters enable you to manage Bonjour announcements at the VSC, user, or AP level, letting you control which Bonjour services wireless clients are able to see and/or advertise. Filtering applies only to Bonjour announcements. Bonjour queries are not filtered.

For example:

- If you define a Bonjour inbound filter to block all Bonjour announcements on a particular VSC, then no wireless clients using that VSC will be able to send Bonjour announcements. (Inbound traffic is traffic received by an AP from a wireless client.)
- If you define a Bonjour outbound filter to block all Bonjour announcements except printing services on a particular VSC, then all wireless clients using that VSC will only receive Bonjour announcements advertising printing services. (Outbound traffic is traffic sent by an AP to a wireless client.)

Filter settings are stored in a Bonjour filter profile. Up to 10 profiles can be defined, each targeting specific Bonjour announcements. Once a filter profile has been defined, it can then be assigned to a VSC, AP, or user profile.

Each Bonjour filter profile is composed of one or more rules. Each rule lets you target a specific type of announcement, allowing it to either be forwarded or blocked (discarded). Rules are evaluated in the order that they appear in the profile list. Any announcements that are blocked by a rule are not available to the rules that follow it (and by extension, to other profiles).

NOTE:

- Bonjour filters (and their rules) do not block the connection between two devices, they only stop the discovery of Bonjour services. If a wireless client knows the IP address of a device providing a service, it can establish a connection with that device without using Bonjour.
 - Bonjour filters only stop the discovery of services advertised using the Bonjour protocol. If a service is also advertised by some other discovery protocol (such as uPNP), it can still be discovered using that other protocol.
-

Filter evaluation

When working with access-controlled VSCs

Filter profiles can be applied in a VSC and in user account profiles. For each Bonjour announcement, filters are evaluated in the following order:

1. User profile (with filters either defined locally on the controller or configured via attributes in a user's RADIUS account)
2. VSC
3. Default filter

NOTE: Until an access-controlled user is authenticated, all Bonjour traffic is blocked.

When working with non-access-controlled VSCs

Filter profiles can be applied in a VSC, in user account profiles, and at the AP level. For each Bonjour announcement, filters are evaluated in the following order:

1. User profile (defined locally on the controller or via the user's RADIUS account)
2. VSC
3. AP level (All APs or AP group or individual AP)
4. Default filter

Defining a filter profile

Do the following to define a filter profile:

1. Select **Controller >> Network > Bonjour**. The Bonjour configuration page opens.

Bonjour configuration ?

Gateway ?

Enable Bonjour gateway on the selected interfaces

Available interfaces: Selected interfaces:

Internet network

Traffic management ?

Enable Bonjour traffic management on:

All access-controlled VSCs

All non-access-controlled VSCs on the APs in the group: Default Group [v] Apply

(Currently enabled on 0 of 0 APs)

For more AP group configuration options click [here](#).

Traffic filtering ?

Enable Bonjour traffic filtering on:

All access-controlled VSCs and user profiles

All non-access-controlled VSCs on the APs in the group: Default Group [v] Apply

(Currently enabled on 0 of 0 APs)

For more AP group configuration options click [here](#).

Manage Bonjour Filter Profiles...

Save

2. Enable and configure the gateway described in the section “[Configuring Bonjour gateway](#)” (page 234). Traffic filtering cannot be enabled without first activating Bonjour gateway.
3. Enable and configure traffic management described in the section “[Configuring traffic management](#)” (page 237). Traffic filtering cannot be enabled without first activating traffic management.
4. In the **Traffic filtering** box, enable traffic filtering as follows:
 - **All access-controlled VSCs and user profiles:** Select this option to enable traffic filtering on all access-controlled VSCs that are defined on the controller and bound to any APs, and for all access-controlled user profiles. Traffic filtering cannot be selectively enabled on individual APs or AP groups. It is either on for all access-controlled VSCs or off. (Bonjour filter profiles are not supported at the AP level on access-controlled VSCs.)
 - **All non-access-controlled VSCs on the APs in the group:** Select the AP group on which you want to enable traffic filtering and then select **Apply**. To enable traffic filtering on more than one group, select each group in turn and select **Apply**.
If you want to enable traffic filtering for an individual AP, select **Controlled APs** in the Network Tree, select the AP, and then select **Configuration > Bonjour**.
5. Select **Save**.

- In the **Traffic filtering** box, select **Manage Bonjour Filter Profiles**. The Bonjour filter profiles page opens.

The screenshot shows the 'Bonjour filter profiles' configuration page. At the top, it displays 'Number of matching Bonjour profiles: 0' and a 'Show 25 entries' dropdown. Below this is a 'Filter Bonjour profiles by:' dropdown set to 'All columns' with an 'Apply' button. A second dropdown is set to '-- Select an Action --' with another 'Apply' button. A table with columns 'Name', 'Usage', and 'Number of rules' is present but empty. Navigation links 'First Previous Next Last' and buttons 'Delete Selected Profile(s)' and 'Add New Profile' are visible. The 'Default filter' section has two rows: 'Inbound Bonjour announcements' and 'Outbound Bonjour announcements'. Each row has radio buttons for 'Allow all' and 'Block all', with 'Block all' selected for both. 'Cancel' and 'Save' buttons are at the bottom.

- In the **Default filter** box, specify the action associated with the default filter. The default filter is applied to all inbound and outbound announcements **after** all other active filter profiles have been applied and no match has been found.

Inbound Bonjour announcements

Select the action to apply to inbound Bonjour announcements. Inbound announcements are received by an AP from a wireless client.

- Allow all:** All announcements that have not been blocked by any active filter profile are forwarded by the AP.
- Block all:** All announcements that have not been blocked by any other active filter profile are discarded by the AP.

Outbound Bonjour announcements

Select the action to apply to outbound Bonjour announcements. Outbound announcements are forwarded by an AP to a wireless client.

- Allow all:** All announcements that have not been blocked by any active filter profile are forwarded to wireless clients.
- Block all:** All announcements that have not been blocked by any other active filter profile are discarded and will not reach any wireless clients.

- Select **Save**.

9. In the **Bonjour filter profiles** box, select **Add New Profile**. The Add/Edit Bonjour profile page opens.

10. For **Profile name**, specify a unique name to identify the profile. Names can be up to 64 characters long, but cannot start with a number or contain spaces. Valid characters are: 0-9, a-z, A-Z, and the special characters: ! \$ % ' () * + - . : ; = ? @ [] ^ _ ` { | } The following characters are not supported: " / \ # & < > ~
11. In the **Add rule** box, configure a new rule as follows:
 - **Action:** Select that action that will be applied to all Bonjour traffic matching the rule.
 - **Allow:** Allow all announcements that match this rule to be forwarded to the next rule (or profile).
 - **Block:** Block all announcements that match this rule. These announcements are not forwarded to the next rule (or profile).
 - **Using format instance.service.protocol:** Use the fields to define a rule to match a particular service. Matching is done using the standard format for Bonjour service (mDNS) announcements, which is: *<instance>.<service>.<protocol>.<domain>*.
 - **Instance:** Specify the name of the service. This is generally a descriptive name that identifies the service. For example: *Accounting_printer*. Leave this field blank to match any instance name.
 - **Service:** Select a service type from the predefined list. Or, select the magnifying glass button to see a list of services that are visible on the network but are not in the predefined list. Or, select **Other** and specify a service type using the following rules.
 - Must begin with an underscore (*_*) character and cannot contain any other underscore characters
 - Must not end with a hyphen or have two hyphens next to each other
 - Must be between 1 and 15 characters long and contain at least one letter
 - Must contain only the following: A-Z, a-z, 0-9, and hyphen (*-*)

- **Protocol:** Select the protocol used by the service: **TCP**, **UDP**, or **ANY**
- **Domain:** The domain is not configurable, but is always appended to each filter. It is always set to **.local** and cannot be changed.
- **Custom:** Two types of custom names are supported: standard format and custom. Each can be up to 255 characters long.

- **Defining a custom rule using the standard naming format**

Use the following format to define a custom name:

<instance>.<service>.<protocol>.<domain>

The wildcard symbol * can be used to match any number of characters at the beginning and/or end of a string.

The *<domain>* instance does not need to be specified. It is always set to **.local**.

Definition	Description
*.*music*.*	Matches any Bonjour service with music in the service name. For example: <ul style="list-style-type: none"> – laptop.rock_music._tcp – my_computer.music_hall._udp – john_laptop_my_music_1._tcp
*.*music*._tcp	Matches any Bonjour service with music over TCP.
My_Computer*.*.*	Matches any Bonjour service advertised by devices with instance names like: <ul style="list-style-type: none"> – My_Computer – My_Computer_2 – My_Computer_laptop
StudentRoom.appletv._tcp	Matches any Apple TV service hosted by a device called StudentRoom over TCP.
*.*mu*ic.*	Invalid: Wildcard in the middle of the string music .
Music*.*	Invalid: Missing a subsection.
..*.*	New firmware has been successfully uploaded to the AP. Wait until the AP restarts to activate the new firmware.

- **Defining a custom rule using a custom naming format**

Use this option to match names that do not follow the standard format. Up to three wildcard symbols * can be used to match any number of characters. For example:

Definition	Description
music	Matches any string with the string music in it. For example: <ul style="list-style-type: none"> – rock_music – music_2 – my_music_rock
my*computer*	Matches any string starting with the string my and then containing the string computer . For example: <ul style="list-style-type: none"> – my_computer – my_computer_2 – my_cComputer_laptop
*tcp	Matches any string ending with tcp .

12. Select **Add**. The rule gets added to the Rules box. You can define up to 10 rules.
13. Select **Save** when done.

Assigning filter profile

Assigning a filter profile to an AP or group

1. To assign a profile to a group, select **Controlled APs >> Configuration > Bonjour**.
To assign a profile to an AP, select **Controlled APs [group] [AP] >> Configuration > Bonjour**. In either case the same configuration page is displayed.
2. Under **Bonjour announcements filtering**, select an inbound and/or outbound profile.

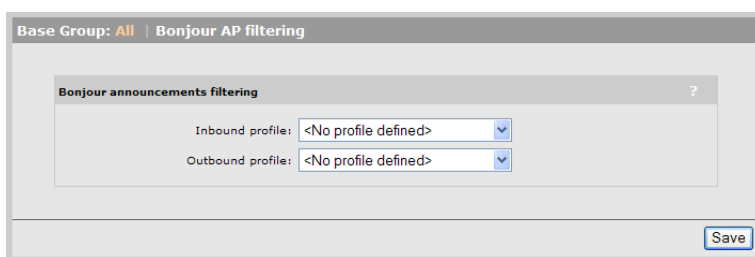

3. Select **Save**.

Assigning a filter profile to a VSC

1. For a new VSC, select **VSCs >> Overview > VSC profiles > Add New VSC Profile**.
For an existing VSC, select its name in the VSC list, or in the **Network Tree**.
2. Under **Bonjour traffic filtering**, select an inbound and/or outbound profile.

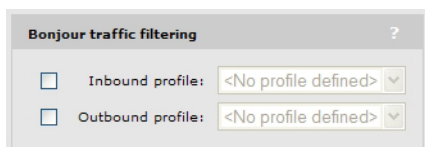

3. Select **Save**.

Assigning a filter profile to a user profile

1. Select **Controller >> Users > Account profiles**.
2. For a new user profile, select **Add New Profile**.
For an existing VSC, select its name in the list.
3. Under **Bonjour traffic filtering**, select an inbound and/or outbound profile.

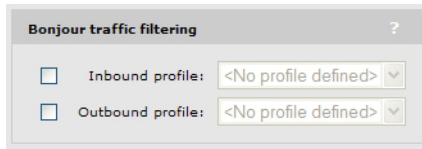

4. Select **Save**.

Assigning a filter profile to a user via RADIUS

Two RADIUS VSAs (vendor-specific attributes) have been created to allow administrators to specify the names of the inbound and outbound Bonjour profiles to use in a user's RADIUS account.

hp-bonjour-inbound-profile

This attribute is used to set the filter profile to use for inbound Bonjour announcements.

You may need to define this attribute on your RADIUS server (if it is not already present) using the following values:

- SMI network management private enterprise code = 8744
- Vendor-specific attribute type number = 66
- Attribute type = string specifying the name of an existing Bonjour filtering profile.

hp-bonjour-outbound-profile

This attribute is used to set the filter profile to use for outbound Bonjour announcements.

You may need to define this attribute on your RADIUS server (if it is not already present) using the following values:

- SMI network management private enterprise code = 8744
- Vendor-specific attribute type number = 67
- Attribute type = string specifying the name of an existing Bonjour filtering profile.

14 Controller teaming

This chapter describes how to combine multiple controllers into a team. Controller teaming provides the following key benefits: centralized management and monitoring, service scalability, and redundancy in case of controller failure.

Teaming overview

Teaming operates slightly differently depending on the controller model you use to create a team.

Teaming on the MSM760, MSM765 zl, and MSM775 zl

Up to five MSM760/MSM765 zl/MSM775 zl controllers can be combined into a team, enabling support for up to 800 APs (four controllers x 200 APs per controller plus one additional controller for backup/redundancy). For example:

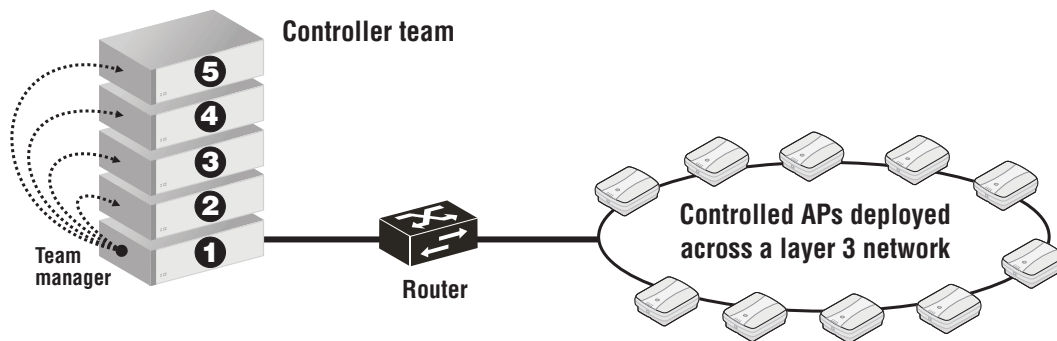

Teaming on the MSM720

On the MSM720, controller teaming operates in a slightly different manner than on the other controllers. The MSM720 can only form a controller team with one other MSM720. This is intended to provide resiliency of service for smaller locations that require fail-over support to ensure that wireless services continue to function if a controller becomes inoperative. It does not provide for scalability of the number of users or managed APs.

Teaming does not increase the number of APs, active users, or local accounts that are supported. This means that the maximum number of APs supported by a stand-alone MSM720 (40) is the same as for a pair of teamed MSM720s.

Key concepts

Centralized configuration management

Each controller that is part of a team is called a *team member*. To centralize management and control of the team, one controller is designated as the *team manager*. Configuration and monitoring of team members and their APs is performed on the team manager using its management tool. For more information, see [“Team configuration”](#) (page 267).

Team management IP address

The team management IP address is a virtual IP address that provides access to the management tool on the currently active team manager, and all other management interfaces: CLI, SNMP, and SOAP. (It can also be used by services such as wireless mobility, location tracking, and Aeroscout). Because this is a virtual address, if the current team manager becomes inoperative and is replaced by another team member, the virtual address is automatically transferred to the new manager, ensuring that the team can continue to be managed at the same IP address. The team management IP address cannot be used for discovery of controlled APs.

Team control channel

The team control channel is a connection that is established between each team member and the team manager. The control channel is used to exchange team management information. On the MSM720, it is HP recommends that you use a dedicated port for the control channel.

Firmware updates

The team manager is responsible for enforcing and updating the firmware of team members. An update to the team manager firmware triggers an update of all members and their controlled APs, ensuring that the entire network is running the same firmware. The synchronization of firmware between controllers and APs alleviates any potential issue regarding compatibility.

Centralized monitoring and operation

The team manager is responsible for handling the addition and deletion of controlled APs, including newly discovered APs. It also displays status information for all team members and their APs, as well as APs directly connected to the manager. For more information, see [“Viewing team members” \(page 266\)](#).

Redundancy and failover support

The team provides for service redundancy in case of failure. If one of the controllers in a team becomes inoperative (due to hardware failure, etc.), its APs will automatically migrate to another controller in the team allowing for continuation of services. For this to work, sufficient capacity must be available on the remaining controllers in the team to support the APs from the inoperative controller. For more information, see [“Failover” \(page 271\)](#).



IMPORTANT:

- When a controller becomes inoperative and failover occurs, all services provided by the controller are temporarily interrupted. Once failover is complete and services return, users that were connected to an access-controlled VSC must login again.
- Once failover is complete, APs may not reestablish a control channel with the controller to which they were connected before failover occurred. They may connect to the same controller, or another controller in the team.

Scalability

Scalability does not apply to MSM720 controller teams.

Controller teaming enables you to scale up your wireless network as your needs increase. Simply add additional APs, controllers, and licenses to meet the required demand. Up to 800 APs are supported per team in its maximum configuration (four controllers x 200 APs per controller plus one additional controller for backup/redundancy).

Deployment considerations

Controllers/APs

- A controller can only be a member of one team at a time.
- All controllers in a team must be the same model.
- Up to five MSM760, MSM765 zl, or MSM775 zl controllers can be combined into a team, supporting up to 800 APs (four controllers x 200 APs per controller + one controller reserved for backup purposes).
- Only two MSM720 controllers can be combined into a team supporting up to 40 APs.

Licensing

- MSM720 and MSM760 controllers must have the Premium Mobility License installed to support teaming. (Licenses must be installed individually on each controller that is part of the team.) MSM765 zl and MSM775 zl controllers are shipped with this license pre-installed.
- You must install enough AP licenses to support all the APs you intend to manage with the team. When teaming is enabled, AP licenses are pooled across all controllers. See [“Failover” \(page 271\)](#) for more information on how AP licenses are managed.

Networking

- The connectivity settings you define on the team manager must be the same on all team members for all ports, VLANs, etc. For example, if the LAN port on the team manager (Access network on the MSM720) is on subnet 192.168.5.0, then all team members must also have their LAN port (Access network) on the same subnet. As a result, any ports on a switch to which the controllers are connected must also be configured identically.
IMPORTANT: All team members must have an IP address assigned to their LAN port (Access network on the MSM720). *This must be done even if the LAN port (Access network on the MSM720) is not connected or not used in your setup.*
- To avoid creating loops in your network, always configure teaming setting before interconnecting the controllers.
- On the MSM720, the port used for the teaming control channel (configured under **Control channel** on the **Controller > Management > Teaming** page) cannot be part of a trunk. HP recommends that you use a dedicated port for teaming.
- The IP address used for the teaming control channel (configured under **Control channel** on the **Controller > Management > Teaming** page) cannot be on the same subnet as the LAN port or Internet port (Access network or Internet network on the MSM720).
- The DHCP server feature is not supported when controller teaming is active, therefore an external DHCP server needs to be installed to support dynamic address assignment to controlled APs and their users.
- APs do not have to be located on the same subnet as the team, and can be connected to the team via an L3 network (using either DNS, DHCP option 43, or by having provisioning the AP). However, all APs must reach the team on the same interface (either LAN port or VLAN). This means that you cannot connect one AP to the team via the LAN port and another via a VLAN.
- If the APs are provisioned for controller discovery, then the APs must be provisioned to discover all controllers in the team, not just the team manager, otherwise failover is not supported.
- Multiple teams can be installed on the same subnet. If this is done, make sure that APs are properly provisioned so that they can only associate with controllers from the correct team.
- To successfully support controller teaming, the network that connects the controllers must not block TCP port 4999 and UDP ports 4999, 38215, and 51936.

Public access

(For more information, see [“Guest access and teaming” \(page 276\)](#).)

- Customization of the public access interface web content should be done via attributes retrieved from a third-party RADIUS server. If RADIUS is not available, you must manually configure each controller in the team with matching settings.
- Payment services are not supported.

Users

- Wired users are only supported if connected to a switch port on the HP 517 or MSM317. Wired users cannot connect directly to the Ethernet ports on any controller that is part of a team.
- The local user accounts do not support subscription plans when teaming is enabled.
- Accounting persistence is not supported.

Firmware

- When a controller becomes a member of a team, its firmware and configuration will be updated by the team manager. This means that almost all configuration settings on the controller will be lost, including any VSC definitions. You can keep a record of the settings on the controller by backing up its configuration before enabling teaming.

Unsupported features

The following features are not supported when teaming is enabled:

- DHCP server
- L2TP server
- PPTP server
- PPTP client
- Subscription plans
- Payment services
- Accounting persistence
- Billing records
- Configuring an ingress VLAN on a VSC
- Connecting wired clients to the LAN port (Access network on the MSM720) on a controller
- Autonomous APs or third-party APs using the controller team for authentication services

For limitations that apply when configuring a team to support guest access, see [“Guest access and teaming” \(page 276\)](#).

Creating a team

The following list is an overview of the key steps you need to execute when creating a controller team. The [“Configuration examples” \(page 250\)](#) shows how to apply these steps to actually create a team.

- **Install licenses:** Install the Premium licenses on each controller and the required number of AP licenses. (MSM765 zl and MSM775 zl controllers are shipped with the Premium license pre-installed.) AP licenses are pooled when controllers are teamed. For more information, see [“Failover” \(page 271\)](#).
- **Configure connectivity:** Define the connectivity settings that controllers will use to discover a team manager and establish a secure control channel with it.
When teaming two MSM720s, you must use a VLAN to carry the control channel. You can assign this VLAN on any port that is in use. However, it is strongly recommended that you use a dedicated port to carry the control channel.
Make sure to define a DNS server and default gateway on each controller.
- **Configure DHCP services:** Configure a third-party DHCP server to handle address assignment for APs and wireless users. (The DHCP server feature on all team members is automatically

disabled when the teaming is enabled.) In addition, you may need to enable DHCP relay on the team, depending on your network topology, to forward DHCP requests to the third-party DHCP server.

- **Configure the team:** Enable teaming on each controller by selecting **Controller >> Management > Teaming**. On the controller that will act as the team manager, set the **Team name** and **Team IP address**.
- **Authorize discovered controllers:** The first time that a controller is discovered by the team manager, it must be manually authorized by an administrator (unless the controller was manually added to the team). To authorize a discovered controller, select **Controllers >> Overview > Discovered controllers** and select **Authorize** in the **Action** column.
- **Install APs:** Connect all APs. The APs will automatically discover the team (if on the same subnet) and be synchronized with the firmware and configuration settings on the manager. If APs are installed on a different subnet than the controller, their discovery settings may need to be provisioned for them to successfully discover the team.

About the team management IP address

Once a team is operational, you should always use the team management IP address to reach the management tool on the team manager, and not the physical address assigned to the manager. In case of failover, the team management IP address will be assigned to the interim manager. This way, you will always be able to manage the team.

Important notes about the team management IP address:

- The team management IP address cannot be used when provisioning APs for discovery. APs must be provisioned with the actual IP addresses assigned to each team member and not the team management IP address.
- When configuring RTLS, the team management IP address should be used. See [“AeroScout RTLS” \(page 179\)](#).
- When mobility discovery is configured, the team management IP address should be used to identify the controller team. See [“Mobility support” \(page 273\)](#).

Configuration examples

Teaming three MSM760s

The following example illustrates the team creation process in detail using a simple topology featuring three teamed MSM760 controllers and four APs. The topology for this example looks like this:

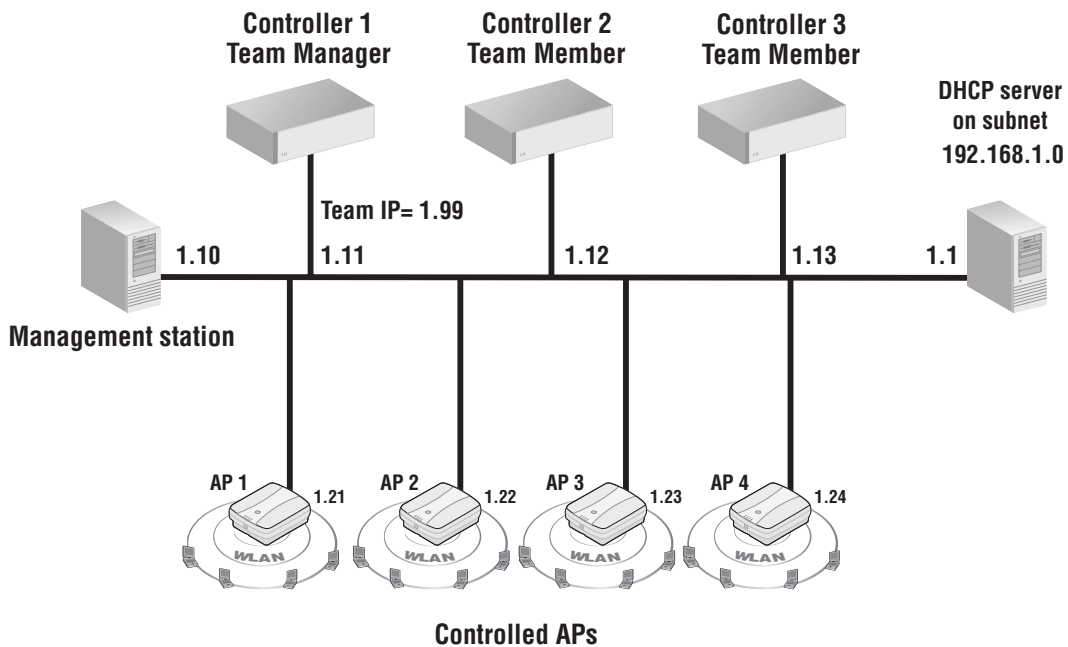

The controllers are connected to the network (192.168.1.0) via their LAN ports. Static addressing is used on each port.

Configure connectivity and licenses on each controller

Use the management station to connect to each controller in turn and do the following:

1. Select **Controller >> Maintenance > Licenses**. Install the Premium license and any required AP licenses. For information on how to install licenses, see [“Managing licenses” \(page 541\)](#).
2. Select **Controller >> Network > IP interfaces**.
3. Select **LAN port**. Set the static IP address as shown in the diagram.

Configure the team

On controller 2 and controller 3, do the following:

1. Select **Controller >> Management > Teaming**.
2. Select the **Controller teaming** checkbox.

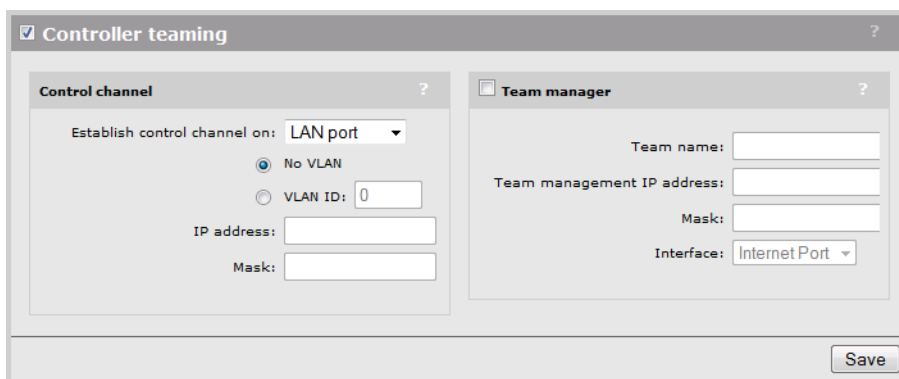

3. Under **Control channel**, set **Establish control channel on** to **LAN port**.
4. Select **No VLAN**.
5. Select **Save**.

- The **Network Tree** will no longer be visible. The **Summary** box will show **Teaming** with a blinking gray status light. This indicates that the controller is searching for a team.

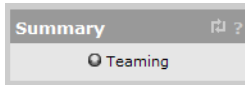

On controller 1, do the following:

- Select **Controller >> Management > Teaming**.
- Select the **Controller teaming** checkbox.

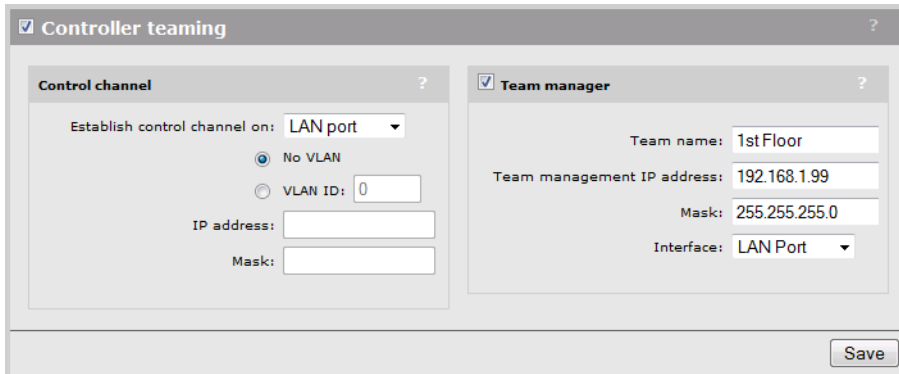

- Under **Connectivity**, set **Establish control channel on** to **LAN port**.
- Select **No VLAN**.
- Select the **Team manager** checkbox, and configure the following settings under it:
 - Set **Team name** to a name that identifies the team. This example uses **1st Floor**. The team name provides a convenient way to identify a team.
 - Set **Team management IP address** to the virtual IP address that will be used to provide access to the team manager. This example uses the address **192.168.1.99**.
 - Set **Mask** to **255.255.255.0**.

Note: If the **Team IP address** is on the same subnet as the physical address assigned to the selected **Interface**, then you must set **Mask** to match the IP mask set on the physical interface. This applies even if the physical interface is set to act as a DHCP client.

 - Set **Interface** to **LAN port**. This makes the **Team IP address** available on the LAN port.
- Select **Save**.
- Controller 2 and 3 will now attempt to discover the manager. Monitor the **Summary** box until you see two **Unauthorized** controllers in the list.

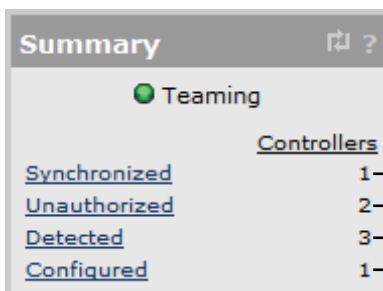

- Indicates team manager is synchronized.
- Indicates two new controllers have been discovered.
- Indicates team manager and two new controllers were detected.
- Indicates team manager is configured.

- Under **Network Tree**, select **Controllers** to view more detailed information about the discovery process. The two new controllers should be listed in red. Select **Authorize** in the **Action** column for each controller.

Summary: Unauthorized | Discovered controllers

Number of controllers: 2

Select the action to apply to all listed controllers: -- Select an Action -- Apply

Status	Controller name	Serial number	Access Points	Diagnostic	Action
Not authorized	SG9313P07X	SG9313P07X	0	Not authorized	Authorize
Not authorized	SG9313P07M	SG9313P07M	0	Not authorized	Authorize

Network Tree

- Team: 1st Floor
 - VSCs
 - Controllers
 - SG9163P01T (manager)
 - Controlled APs

- The manager will now attempt to authorize and synchronize controllers 2 and 3. Once synchronized, their status will change to green.

Controllers: All | Discovered controllers

Number of controllers: 3

Select the action to apply to all listed controllers: -- Select an Action -- Apply

Status	Controller name	Serial number	Access Points	Diagnostic	Action
Synchronized	SG9163P01T	SG9163P01T	3	Synchronized	Remove
Synchronized	SG9313P07X	SG9313P07X	0	Synchronized	Remove
Synchronized	SG9313P07M	SG9313P07M	0	Synchronized	Remove

Network Tree

- Team: 1st Floor**
 - VSCs
 - Controllers
 - SG9163P01T (manager)
 - SG9313P07X
 - SG9313P07M
 - Controlled APs

For more information on summary states and the **Network Tree**, see [“Monitoring the discovery process” \(page 262\)](#).

Once all members are synchronized, the team is ready for further configuration. See [“Team configuration” \(page 267\)](#) for details.

Teaming two MSM720s using a dedicated port

The easiest and best way to create a team with two MSM720s is to use a dedicated port on each device to provide the connection on which to establish the team control channel. The dedicated port is for teaming use only, and cannot be a member of a trunk or be used to carry other VLANs. This example connects two controllers using port 1 and summarizes the configuration settings on each controller. The steps that follow illustrate how to define the required configuration settings on each controller.

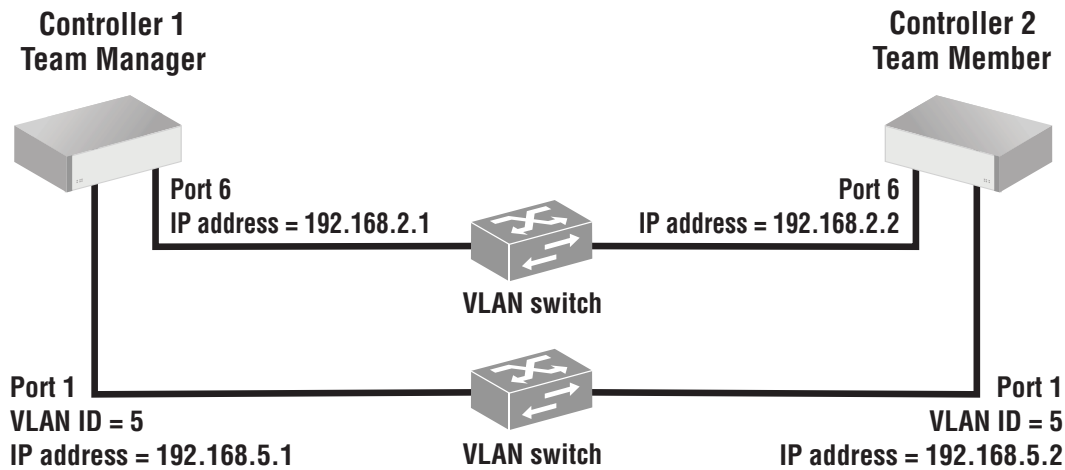

The controllers are connected to each other using port 1 and the teaming control channel will be established on this port. (Note that the port used for the teaming control channel cannot be part of a trunk.) A VLAN (5) and an IP address (192.168.5.1 or 192.168.5.2) are assigned to port 1 on each controller. The IP addresses can be on any network except 192.168.1.0, which is used by default by the Access network, and 192.168.2.0, which is assigned to the Internet network. Since the VLAN is tagged, the corresponding ports on the VLAN switch must also be tagged. (You can also directly connect the ports to each other and eliminate the need for a VLAN switch.)

Port 6 is used to provide connectivity for the controllers. It is assigned to the Internet network interface. For convenience, the team IP management address (which is used to access the management tool on the team manager) is set to 192.168.2.200 on the same subnet as the Internet network). It could however, be on a different subnet.

NOTE: The teaming VLAN does not appear in the VLAN list on the **Controller >> Network > VLANs** page. It is only visible on the **Controller >> Management > Teaming** page.

Do not connect either controller to the network until all configuration settings are complete.

Configure connectivity on each controller

Use the management station to connect to each controller in turn and do the following:

1. Select **Controller >> Network > IP interfaces**.
2. Select **Internet network**. Set the static IP address as shown in the diagram for port 6. Select **Save**.

Configure the team

On controller 2, do the following:

1. Select **Controller >> Management > Teaming**.
2. Select the **Controller teaming** checkbox.

The screenshot shows the configuration interface for controller teaming. The 'Controller teaming' checkbox is checked. The 'Control channel' section is expanded, showing 'Establish control channel on:' set to 'Port 1'. Below this, the 'Dedicate this port for teaming' checkbox is checked. The 'VLAN ID:' is set to 5, the 'IP address:' is 192.168.5.2, and the 'Mask:' is 255.255.255.0. The 'Team manager' section is collapsed, showing the 'Team manager' checkbox is unchecked. The 'Team name:', 'Team management IP address:', and 'Mask:' fields are empty. The 'Interface:' dropdown is set to 'Internet network'. A 'Save' button is located at the bottom right of the form.

3. Under **Control channel**:
 - Set **Establish control channel on** to **Port 1**.
 - Select the **Dedicate this port for teaming** checkbox.
 - Set **VLAN ID** to **5**. This creates the teaming control channel on VLAN 5, tagged, on port 1 on the controller. (Important: This VLAN is not shown on the **Controller > Network > VLANs** page, and is not created using a network profile. It is explicitly defined here only.) Make sure that the network switch to which this port is connected is also configured with VLAN 5, tagged.
 - Set **IP address** to **192.168.5.2**, which is the IP address this controller will use to establish the teaming control channel. The IP addresses for all teamed controllers must be on the same subnet. This subnet cannot be the same as the subnet used for **Team management IP address**, or for the Access network or Internet network.
 - Set **Mask** to **255.255.255.0**.
4. Select **Save**.
5. The **Network Tree** will no longer be visible. The **Summary** box will show **Teaming** with a blinking gray status light. This indicates that the controller is searching for a team.

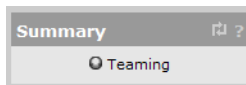

On controller 1, do the following:

1. Select **Controller >> Management > Teaming**.
2. Select the **Controller teaming** checkbox.

 A screenshot of a configuration window titled "Controller teaming" with a checked checkbox and a question mark icon. The window is divided into two main sections: "Control channel" and "Team manager".

 In the "Control channel" section:

- "Establish control channel on:" is set to "Port 1" (dropdown menu).
- The checkbox "Dedicate this port for teaming" is checked.
- "VLAN ID:" is set to "5" (text input).
- "IP address:" is set to "192.168.5.1" (text input).
- "Mask:" is set to "255.255.255.0" (text input).

 In the "Team manager" section:

- The checkbox "Team manager" is checked.
- "Team name:" is set to "Team 1" (text input).
- "Team management IP address:" is set to "192.168.2.200" (text input).
- "Mask:" is set to "255.255.255.0" (text input).
- "Interface:" is set to "Internet network" (dropdown menu).

 At the bottom right of the window is a "Save" button.

3. Under **Control channel**:
 - Set **Establish control channel on** to **Port 1**.
 - Select the **Dedicate this port for teaming** checkbox.
 - Set **VLAN ID** to **5**.
 - Set **IP address** to **192.168.5.1**, which is the IP address this controller will use to establish the teaming control channel.
 - Set **Mask** to **255.255.255.0**.

4. Select the **Team manager** checkbox, and configure the following settings under it:
 - Set **Team name** to a name that identifies the team. This example uses **Team 1**. The team name provides a convenient way to identify a team.
 - Set **Team management IP address** to the virtual IP address that will be used to provide access to the management tool on the team manager. This example uses the address **192.168.2.200**. This address **must be on a different subnet** than the IP address assigned under **Control channel**. However, it can be on the same subnet as the selected interface.
 - Set **Mask** to **255.255.255.0**.
 - Set **Interface** to **Internet network**. This makes the **Team management IP address** available on ports 5 and 6.
5. Select **Save**.
6. Controller 2 will now attempt to discover the manager. Monitor the **Summary** box until you see an **Unauthorized** controller in the list.

Summary

Teaming

Controllers	
Synchronized	1 — Indicates team manager is synchronized.
Unauthorized	1 — Indicates new controller has been discovered.
Detected	2 — Indicates team manager and a new controller were detected.
Configured	1 — Indicates team manager is configured.

7. Under **Network Tree**, select **Controllers** to view more detailed information about the discovery process. The two new controllers should be listed in red. Select **Authorize** in the **Action** column for the controller.

Summary: Unauthorized | Discovered controllers

Number of controllers: 2

Select the action to apply to all listed controllers: -- Select an Action -- Apply

Status	Controller name	Serial number	Access Points	Diagnostic	Action
●		SG9313P07X	0	Not authorized	Authorize

Network Tree

- Team: Team 1
 - VSCs
 - Controllers
 - SG9163P01T (manager)
 - Controlled APs

8. The manager will now attempt to authorize and synchronize controller 2. Once synchronized, their status will change to green.

Controllers: All Discovered controllers					
Number of controllers: 2					
Select the action to apply to all listed controllers: -- Select an Action --					Apply
Status	Controller name	Serial number	Access Points	Diagnostic	Action
●	SG9163P01T	SG9163P01T	3	Synchronized	Remove
●	SG9313P07X	SG9313P07X	0	Synchronized	Remove

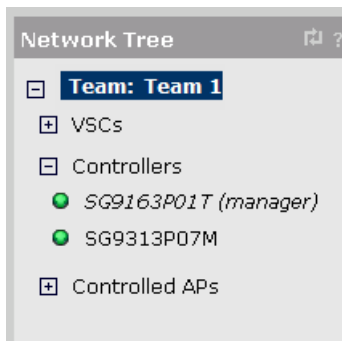

For more information on summary states and the **Network Tree**, see [“Monitoring the discovery process” \(page 262\)](#).

Once all members are synchronized, the team is ready for further configuration. See [“Team configuration” \(page 267\)](#) for details.

Teaming two MSM720s using the Access network or Internet network

If you do not want to use a dedicated port to team two MSM720s, you can use a dedicated VLAN on either the Access network or Internet network. This example uses the Access network, but the same strategy can be applied to the Internet network. The following diagram summarizes the configuration settings on each controller. The steps that follow illustrate how to define these settings.

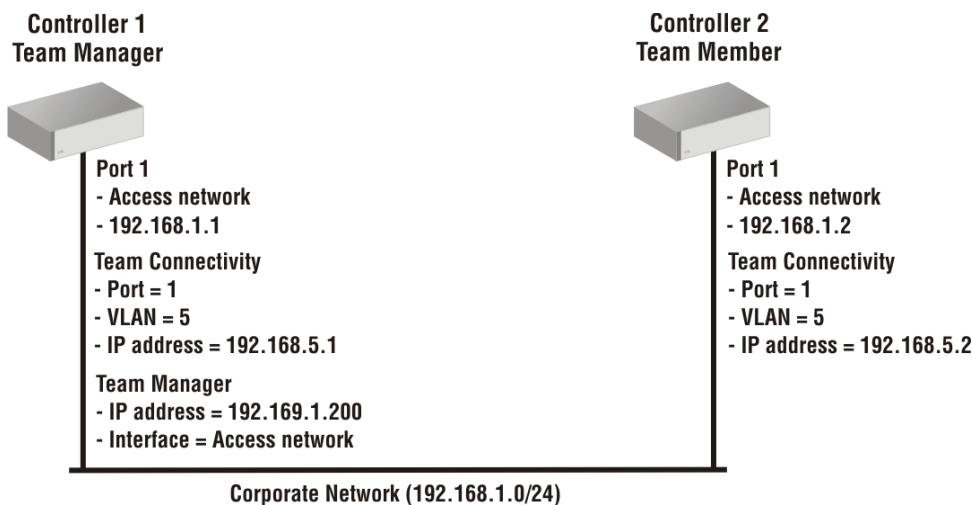

The controllers are connected to the network (192.168.1.0) via port 1 (using a static IP address). By default, the Access network is assigned to ports 1, 2, 3, 4 and uses VLAN 1, untagged. The teaming control channel is created on VLAN 5, which is also bound to port 1 (Access network). This is a tagged VLAN, so the corresponding port on the network switch must also be tagged on

VLAN 5. If you want to use another port on the controller, read the following information regarding network loops.

To avoid creating a network loop it is important that you configure each MSM720 first before interconnecting them. The reason a loop can occur is due to the default configuration setting of the MSM720, which is:

- Ports 1, 2, 3, 4 are untagged on the Access network (VLAN 1).
- Ports 5, 6 are untagged on the Internet network (VLAN 10).

If you connect port 1 to the network and use port 2 to link the two MSM720s, a loop will occur because port 2 is assigned to VLAN 1 (untagged) on both ports. The solution is to first move port 2 to its own VLAN, assign the teaming VLAN to it, and only then connect it.

The IP addresses used for teaming connectivity (192.168.5.1 and 192.168.5.2) can be on any network except 192.168.1.0 which is already used by the Access network.

For convenience, the team IP address (which is used to access the management tool on the team manager) is set to 192.168.1.200 (on the same subnet as the Access network). It could however, be on a different network. Since port 1 provides connectivity for the controller, the team IP address is assigned on the Access network interface.

NOTE: The teaming VLAN does not appear in the VLAN list on the **Controller >> Network > VLANs** page. It is only visible on the **Controller >> Management > Teaming** page.

Do not connect the controllers to the network until all configuration settings are complete.

Configure connectivity and licenses on each controller

Use the management station to connect to each controller in turn and do the following:

1. Select **Controller >> Maintenance > Licenses**. Install the Premium license and any required AP licenses. For information on how to install licenses, see [“Managing licenses” \(page 541\)](#).
2. Select **Controller >> Network > IP interfaces**.
3. Select **Access network**. Set the static IP address as shown in the diagram. Select **Save**.

Configure the team

On controller 2, do the following:

1. Select **Controller >> Management > Teaming**.
2. Select the **Controller teaming** checkbox.

Controller teaming ?

Connectivity ?

Communicate using: Port 1

VLAN ID: 5

IP address: 192.168.5.2

Mask: 255.255.255.0

Team manager ?

Team name:

Team IP address:

Mask:

Interface: Internet network

Save

3. Under **Connectivity**:
 - Set **Communicate using** to **Port 1**.
 - Set **VLAN ID** to **5**. This creates the teaming control channel on VLAN 5, tagged, on port 1 on the controller. (Important: This VLAN is not shown on the **Controller > Network > VLANs** page, and is not created using a network profile. It is explicitly defined here only.) Make sure that the network switch to which this port is connected is also configured with VLAN 5, tagged.
 - Set **IP address** to **192.168.5.2**, which is the IP address this controller will use to establish the teaming control channel. The IP addresses for all teamed controllers must be on the same subnet. This subnet cannot be the same as the subnet used for **Team IP address**, or for the Access network or Internet network.
 - Set **Mask** to **255.255.255.0**.
4. Select **Save**.
5. The **Network Tree** will no longer be visible. The **Summary** box will show **Teaming** with a blinking gray status light. This indicates that the controller is searching for a team.

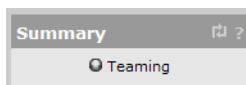

On controller 1, do the following:

1. Select **Controller >> Management > Teaming**.
2. Select the **Controller teaming** checkbox.

 A screenshot of the 'Controller teaming' configuration window. The window has a title bar with a checked checkbox and the text 'Controller teaming'. It is divided into two main sections: 'Connectivity' and 'Team manager'.

 The 'Connectivity' section contains:

- 'Communicate using:' with a dropdown menu set to 'Port 1'.
- 'VLAN ID:' with a text input field containing '5'.
- 'IP address:' with a text input field containing '192.168.5.1'.
- 'Mask:' with a text input field containing '255.255.255.0'.

 The 'Team manager' section contains:

- A checked checkbox next to the section title.
- 'Team name:' with a text input field containing 'Team 1'.
- 'Team IP address:' with a text input field containing '192.168.1.200'.
- 'Mask:' with a text input field containing '255.255.255.0'.
- 'Interface:' with a dropdown menu set to 'Access network'.

 At the bottom right of the window is a 'Save' button.

3. Under **Connectivity**:
 - Set **Communicate using** to **Port 1**.
 - Set **VLAN ID** to **5**.
 - Set **IP address** to **192.168.5.1**, which is the IP address this controller will use to establish the teaming control channel.
 - Set **Mask** to **255.255.255.0**.
4. Select the **Team manager** checkbox, and configure the following settings under it:
 - Set **Team name** to a name that identifies the team. This example uses **Team 1**. The team name provides a convenient way to identify a team.
 - Set **Team IP address** to the virtual IP address that will be used to provide access to the management tool on the team manager. This example uses the address **192.168.1.200**.

This address **must be on a different subnet** than the IP address assigned under **Connectivity**. However, it can be on the same subnet as the selected interface.

- Set **Mask** to **255.255.255.0**.
 - Set **Interface** to **Access network**. This makes the **Team IP address** available on port 1.
5. Select **Save**.
 6. Controller 2 will now attempt to discover the manager. Monitor the **Summary** box until you see an **Unauthorized** controller in the list.

Summary

Teaming

Controllers

Synchronized	1	Indicates team manager is synchronized.
Unauthorized	1	Indicates new controller has been discovered.
Detected	2	Indicates team manager and a new controller were detected.
Configured	1	Indicates team manager is configured.

7. Under **Network Tree**, select **Controllers** to view more detailed information about the discovery process. The two new controllers should be listed in red. Select **Authorize** in the **Action** column for the controller.

Summary: Unauthorized | Discovered controllers

Number of controllers: 2

Select the action to apply to all listed controllers: -- Select an Action -- Apply

Status	Controller name	Serial number	Access Points	Diagnostic	Action
Unauthorized		SG9313P07X	0	Not authorized	Authorize

Network Tree

- Team: Team 1
 - VSCs
 - Controllers
 - SG9163P01T (manager)
 - Controlled APs

8. The manager will now attempt to authorize and synchronize controller 2. Once synchronized, their status will change to green.

Controllers: All Discovered controllers					
Number of controllers: 2					
Select the action to apply to all listed controllers: -- Select an Action --					Apply
Status	Controller name	Serial number	Access Points	Diagnostic	Action
●	SG9163P01T	SG9163P01T	3	Synchronized	Remove
●	SG9313P07X	SG9313P07X	0	Synchronized	Remove





Network Tree	
[-]	Team: Team 1
[+]	VSCs
[-]	Controllers
●	SG9163P01T (manager)
●	SG9313P07M
[+]	Controlled APs

For more information on summary states and the **Network Tree**, see [“Monitoring the discovery process”](#) (page 262).

Once all members are synchronized, the team is ready for further configuration. See [“Team configuration”](#) (page 267) for details.

Controller discovery

The following is an overview of key events that occur when a controller attempts to discover and join a team for the first time.

Manager		Controller
The team manager receives a discovery request. If this is the first time that the controller is discovered by the team, the controller must be manually authorized by an administrator before it can join the team and become an active member.		The controller sends a discovery request onto the local network.
		
The manager sends a discovery reply.		The controller receives the discovery reply. If more than one reply is received, the controller chooses the manager that replied first.
		
The manager adds the controller to the team.		The controller joins the team associated with the selected manager.

Manager		Controller
↓		
If controller has software that is out of date, the manager tells the controller to update its software.	→	The controller retrieves new software from the manager, installs it, and then restarts. Discovery is performed again.
		↓
The manager accepts the secure management tunnel.	←	Once the manager has been discovered, the controller establishes a secure management tunnel with the manager.
↓		
The manager updates the controllers configuration.	→	The controller receives new configuration settings. Once this is done, the controller will always attempt to discover this team manager and will not join any other teams until it is manually removed from this team.
		↓
		The controller is now an active member of the team. Any APs managed by the controller are automatically updated with the settings on the manager.

Monitoring the discovery process

The **Summary** box and **Network Tree** on the team manager provide an overview of the discovery process.

Summary box

The **Summary** box provides an overview of the status of controllers and controlled APs.

Summary	
● Teaming	
<u>Controllers</u>	
Synchronized	3
Detected	3
Configured	3
<u>Controlled APs</u>	
Synchronized	5
Detected	5
Configured	6

Settings

Teaming light

This light indicates how the team is being managed.

- **Green:** This controller is the primary team manager.
- **Yellow:** The primary team manager has become inoperative and an interim team manager has taken over. For details, see [“Failover” \(page 271\)](#).

Controllers

This section shows the number of controllers that are active in each management state. A controller may be active in more than one state at the same time. For example, a controller may be both **Detected** and **Synchronized**. Select the state name to display information about all controllers in that state.

- **Configured:** These controllers are configured as part of the team.
- **Synchronized:** These controllers had their software and configuration settings successfully updated by the team manager and are fully operational.
- **Unsynchronized:** This can occur if the primary manager becomes non-functional during the synchronization process leaving one or more team members with partially updated configurations. When the interim manager takes over, it cannot update these controllers. Therefore, the solution is to promote the interim manager to become the primary manager. It can fully synchronize the configuration settings on all controllers.
- **Pending:** An action is in progress. For example, firmware or configuration may be uploading to the controller or the controller is restarting.
- **Unresponding:** These controllers have stopped sending management information to the manager. Rediscovery may re-establish the connection. If not, a network failure may have occurred or the controllers may be inoperative.
- **Unauthorized:** These controllers have not yet been authorized to join the team. Authorization must be performed manually by an administrator by selecting **Controllers >> Overview > Discovered controllers** and then selecting **Authorize** in the **Action** column.
- **Unconfigurable:** These controllers cannot be added because the team already has the maximum number of supported members. To add these controllers you must first remove one or more team members by selecting **Controllers >> Overview > Team members**, then selecting the name of the controller you want to delete and then selecting **Delete**.
- **Detected:** These controllers have sent a discovery request to the team manager and the team manager has replied.
- **Configured:** These controllers are members of the team. They may have been automatically discovered or manually added.

Controlled APs

This section lists the number of controlled APs discovered by the team. APs are grouped according to their management state. For a complete description of all management states, see [“Monitoring the discovery process” \(page 154\)](#).

Network Tree

The **Network Tree** provides access to configuration options for the team, and shows a status light for each controller.

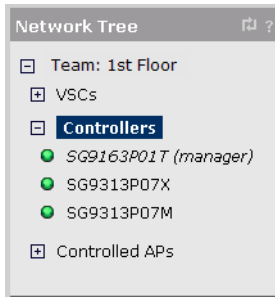

Settings

Team: team name

Select **Team:** [*name*] to access configuration items that apply to all members of the team and their controlled APs. Configure these options using the main menu in the right pane.

VSC

Select the **VSCs** node to manage the virtual service communities that are defined on the team. Once you define a VSC it is automatically synchronized on all member controllers, and can be assigned (bound) to one or more controlled APs.

Status lights

A status light is displayed for each VSC.

- **Green:** Indicates that the VSC is properly configured.
- **Red:** Indicates that the VSC has a configuration problem.

Once you define a VSC it is automatically active on the controller.

Controllers

This section lists all controllers that are members of the team. Team members are controllers that fall into one of the following categories:

- The controller was discovered on the network, authorized by an administrator, and successfully joined the team at least once.
or
- The controller was manually added to the team by selecting **Add New Controller** on the **Overview > Configured controllers** page.

Each controller is identified by a name (which is initially set to the controllers serial number for discovered controllers). Select a controllers name to access configuration items that are specific to the controller. These configuration items are presented in the main menu in the right pane.

Status lights

Controllers that are part of the team are listed under **Controllers** in the **Network Tree**. The status lights provide an indication of their state as follows:

- **Green:** The controller has joined the team and its configuration is synchronized with the settings defined on the team manager. It is fully operational.
- **Red:** The controller is not functioning normally. Select **Overview > Discovered controllers** and refer to the **Diagnostic** column for details.
- **Grey flashing:** An action is pending. Select **Overview > Discovered controllers** and refer to the **Action** column for details.
- **Grey solid:** The controller is configured as a member of the team, but is currently not active.

Viewing discovered controllers

To display information about controllers discovered by the manager, select **Controllers >> Overview > Discovered controllers**.

Status	Controller name	Serial number	Access Points	Diagnostic	Action
●	SG9163P01T	SG9163P01T	5	Synchronized	
●	SG9313P07X	SG9313P07X	0	Synchronized	
●	SG9313P07M	SG9313P07M	0	Synchronized	

The **Discovered controllers** page provides the following:

- **Select the action to apply to all listed controllers:** Lets you apply the selected action to all controllers in the list. Select an action and then **Apply**.
- **Status lights**

A status light is displayed for each controller as follows:

 - **Green:** The controller has joined the team and its configuration is synchronized with the settings defined on the team manager. It is fully operational.
 - **Red:** The controller is not functioning normally. Select **Overview > Discovered controllers** and refer to the **Diagnostic** column for details.
 - **Grey flashing:** An action is pending. Select **Overview > Discovered controllers** and refer to the **Action** column for details.
 - **Grey solid:** The controller is configured as a member of the team, but is currently not active.
- **Controller name:** Name assigned to the controller. By default, this is the controller serial number.
- **Serial number:** Unique serial number assigned to the controller at the factory. Cannot be changed.
- **Access points:** Indicates number of APs connected to the controller.
- **Diagnostic:** Indicates the status of the controller as shown in the following table.

Diagnostic	Description
Detected	The controller sent a discovery request to the team manager and the team manager has replied.
Establishing tunnel	A secure management connection is being established between the team manager and the controller.
Firmware failure	New software failed to upload to the controller. The manager will retry soon.
Installing firmware	New software has been successfully uploaded to the controller. The controller will restart to activate the new software.
Not authorized	The controller has not yet been authorized to join the team. Authorization must be performed manually by an administrator by selecting Authorize in the Action column.
Not responding	The controller has stopped sending management information to the team manager. Rediscovery may re-establish the connection. If not, a network failure may have occurred or the controller may be inoperative.

Diagnostic	Description
Resetting configuration	The controller configuration is being reset to factory defaults. This is normal and will occur when the software version on the manager is changed or if the controller is not synchronized.
Restoring configuration	The controller is currently restoring its previous configuration settings.
Synchronized	The controller had its software and configuration settings successfully updated by the team manager and is fully operational.
Unconfigurable	The controller cannot be added because the team already has the maximum number of supported members. To add the controller you must first remove one or more team members.
Unsupported product	The product type of the controller is not supported on this team. All controllers must have the same product type as the team manager.
Uploading configuration	Configuration settings are currently being sent to the controller.
Uploading firmware	The team manager is uploading new software to the controller. Wait until the operation completes.
Validating capabilities	The capabilities of the controller are being identified by the team manager.
Validating configuration	The team manager is waiting for the controller to send its configuration.
Validating firmware	The team manager is waiting for the controller to send its software version number.
Waiting for acceptance	The controller has been authorized by the team manager. However, the controller has not yet decided to join this team. (If multiple managers replied to the controller discovery request, the controller may choose to connect with a different team.)

- **Action:** Indicates the recommended administrative action to be taken to resolve a diagnostic condition.

Viewing team members

To display information about controllers that are members of the team, select **Controllers >> Overview > Team members**.

Detected	Controller name	Serial number	Product
●	New controller		MSM760
●	SG9163P01T	SG9163P01T	MSM760
●	SG9313P07X	SG9313P07X	MSM760
●	SG9313P07M	SG9313P07M	MSM760

Add

Team members are controllers that fall into one of the following categories:

- The controller was discovered on the network, authorized by an administrator, and successfully joined the team at least once.
- The controller was manually added to the team by selecting **Add New Controller** on the **Overview > Configured controllers** page.

Select the title of a column to sort the table according to the values in the column.

The **Team members** page provides the following information:

- **Number of controllers:** Number of controllers that are configured as members of the team.
- **Detected:** Status light icon indicating if the controller has been discovered on the network.
 - **Green:** The controller has been discovered on the network and is listed on the **Overview > Discovered controllers** page, where more information is provided about the controller.
 - **Red:** The controller was manually added to the team, but it has never been discovered and successfully joined the team.
- **Controller name:** Name assigned to the controller. Select the name to configure controller settings.
- **Serial number:** Serial number assigned to the controller. Select the name to configure controller settings.
- **Product:** Product name of the controller.

Team configuration

Caution: *When using teaming and deploying a guest access solution, you must not use the **Create a wireless network for guests** workflow. Instead, you must manually configure guest access as described in the section [“Guest access and teaming”](#) (page 276).*

Once a team is operational, configuration and management of VSCs and controlled APs occurs via the team manager, using the **VSC** and **Controlled APs** options in the **Network Tree**. Configuration of these elements is the same as during non-teamed operation. Refer to [“Working with VSCs”](#) (page 112) and [“Working with controlled APs”](#) (page 145) for more information.

Configuration settings for the team members however, can occur at three different levels:

- **Team:** These are global configuration settings that are defined using the management tool on the team manager and are synchronized on all team members. Most team configuration settings fall into this category.
- **Controller:** The team manager provides a separate configuration menu for each controller in a team, including the team manager. This allows individual settings specific to a controller to be defined.
- **Local:** The management tool on each controller can also be accessed directly to define any options that are not directly configurable using the team manager. For example, some connectivity settings must be defined locally on each controller.

Accessing the team manager

To reach the management tool on the team manager, you should always point your browser to the team IP address, and not the IP address assigned to the manager. In case of failover, the team IP address will be assigned to the interim manager. This way, you will always be able to configure the team.

Team configuration options

This section describes the configuration options available on the team manager.

When you select **Team** in the **Network Tree**, the menu in the right pane presents all configuration options that are common to all team members. Any settings that you make using this menu are synchronized on all team members.

The available options on this menu are identical to what you would see on a non-teamed controller, except for a few options that are not supported in teaming mode, or if supported, must be defined individually on each controller. On the team manager, these settings can be defined by selecting the manager under **Controller**. Settings for team members must be defined by directly accessing their management tools.

The following table lists the configuration options that are affected when teaming is active.

Configuration option	Notes
Network > IP interfaces	IP addresses cannot be assigned at the team level.
Network > Address allocation	The DHCP server option is not supported when teaming is enabled. The VPN address pool option is not supported when teaming is enabled.
Security > Certificate stores Security > Certificate usage	Not available at the team level. Not available at the team level.
VPN > IPSec VPN > L2TP server VPN > PPTP server VPN > PPTP client	Not available at the team level. Not supported when teaming is enabled. Not supported when teaming is enabled. Not supported when teaming is enabled.
Authentication > Active Directory	The General and Join options are not available at the team level.
Public Access > Web content Public Access > Attributes	The Site file archive , FTP server , and Current site files options are not available at the team level. New attributes cannot be added to the Configured attributes table at the team level.
Users > Subscription plans Users > Accounting persistence	Feature not supported when teaming is enabled. Feature not supported when teaming is enabled.
Management > Teaming	Not available at the team level.
Status	Not available at the team level.
Tools > IPSec Tools > System tools Tools > Network trace Tools > sFlow	Not available at the team level. Not available at the team level. Not available at the team level. Not supported when teaming is enabled.
Maintenance > Registration Maintenance > Licenses	Not available at the team level. Not available at the team level.

Removing a controller from a team

To remove a controller from a team, do the following:

Remove the controller from the team

1. Under **Controllers**, select a team member.
2. In the right pane, select **Device management**.

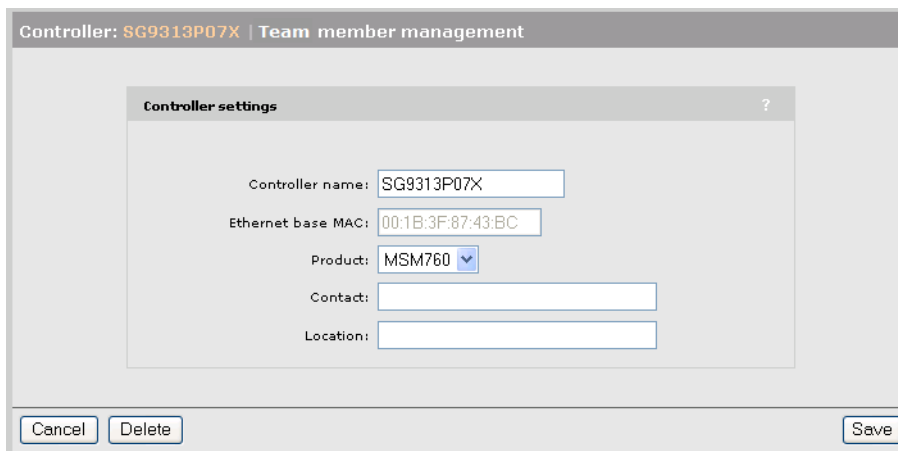

3. Select **Delete**.

Disable teaming on the controller

1. Open the management tool directly on the controller.
2. Select **Management > Teaming**.

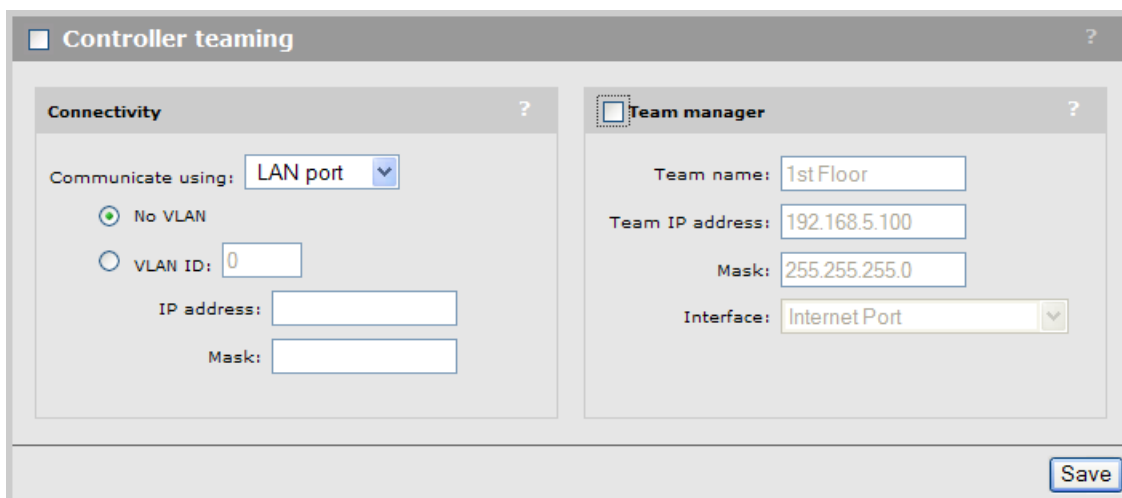

3. Disable the **Controller teaming** option.
4. Select **Save**.

Editing team member settings

To change settings for a team member:

1. Under **Controllers**, select a team member.
2. In the right pane, select **Device management**.

Controller: SG9313P07X | Team member management

Controller settings ?

Controller name:

Ethernet base MAC:

Product:

Contact:

Location:

3. Change settings as required. Note that the **Ethernet base MAC** address cannot be changed. To change the MAC address you must delete the controller and then add it again.
4. Select **Save**.

Manually adding a controller to a team

Instead of using the automatic discovery to find controllers and add controllers to the team, you can manually preconfigure one or more controllers as team members. The main advantages of doing this is that manually added controllers do not have to be manually authorized the first time they are discovered. Instead, they automatically become active team members.

To manually add a controller:

1. Select **Controllers >> Overview > Team members**.

Controllers: All | Team members ?

Number of displayed controllers: 4

Detected	Controller name	Serial number	Product
●	New controller		MSM760
●	SG9163P01T	SG9163P01T	MSM760
●	SG9313P07X	SG9313P07X	MSM760
●	SG9313P07M	SG9313P07M	MSM760

2. Select **Add**.

Controllers: All | Team member management

Controller ?

Add new controller:

Controller name:

Ethernet Base MAC:

Product: **MSM760**

Contact:

Location:

3. Define settings as follows:
 - **Controller name:** Specify a name to identify the controller.
 - **Ethernet base MAC:** Specify the MAC address of the controller. This value cannot be changed once the controller information is saved.
 - **Product:** Displays the product type of the controller.
 - **Contact:** Specify contact information for the controller.
 - **Location:** Specify the location where the controller is installed.
4. Select **Save**.
5. The new controller will appear in the team members list with a red status light until it is discovered on the network.

Detected	Controller name	Serial number	Product
●	New controller		MSM760
●	SG9163P01T	SG9163P01T	MSM760
●	SG9313P07X	SG9313P07X	MSM760
●	SG9313P07M	SG9313P07M	MSM760

Number of displayed controllers: 4

Add

Discovery of a controller team by controlled APs

For a complete discussion of controller discovery, see “[Discovery of controllers by controlled APs](#)” (page 148).

Failover

During normal operation, the team manager and team members are in continuous contact to ensure the integrity of the team. This allows for quick detection of an inoperative or unreachable team member, and implementation of failover procedures to ensure continuity of network services.

NOTE: When a team member becomes inoperative and failover occurs, all services provided by the failed controller are temporarily interrupted. Once failover is complete and services return, users that were connected to an access-controlled VSC on this controller must login again.

Supporting N + N redundancy

The MSM720 only supports N + 1 redundancy with a maximum of 40 APs.

A controller team can be configured to provide different levels of redundancy, from N + 1 up to N + 3. Use the following formula to calculate the number of team members you will need based on the number of APs that you want to deploy and the required level of redundancy.

Required team members = (APs / 200) + Redundancy_level

(If there is a remainder after performing the division, round up.)

Where:

- APs is the total number of APs you want to deploy. You must buy one license for each controlled AP. Although licenses are installed on individual team members, licenses are pooled across the entire team and are automatically re-allocated when a team member becomes inoperative.
- Redundancy_level: This is the number of redundant controllers that you want to support: 1, 2, or 3.

For example:

Number of APs you want to deploy	APs / 200	Number of team members required to support redundancy		
		N + 1	N + 2	N + 3
120	.6	2	3	4
200	1	2	3	4
400	2	3	4	5
440	2.2	4	5	-
520	2.6	4	5	-
600	3	4	5	-
800	4	5	-	-

Another way to look at it is as follows:

Number of team members	Maximum AP licenses that can be installed	Maximum APs you can deploy to ensure redundancy		
		N + 1	N + 2	N + 3
2	400	200	-	-
3	600	400	200	-
4	800	600	400	200
5	800	800	600	400

NOTE: A team supports a maximum of 800 APs and 5 team members.

Primary team manager failure

The controller that is designated as the team manager on the **Controllers > [team-manager] >> Management > Teaming page** is called the *primary* team manager.

If the primary team manager becomes inoperative, an interim team manager is automatically selected by the existing team members. The interim manager assumes the team IP address and all management functions until the primary team manager returns, with the following limitation: the interim manager cannot modify the configuration or update the firmware for members. This is done to avoid the situation where configuration changes made by interim manager are undone by the primary manager when it comes back online.

When an interim manager is active, the **Teaming** status light in the **Summary** box will be yellow.

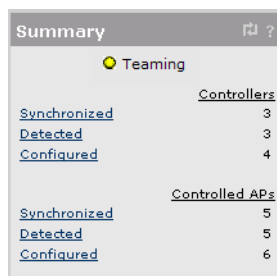

All configurable settings on the menus in the right pane will be grayed out. Status information however, will be visible.

Replacing the team manager

If the primary team manager has failed and will not be returning, you can promote the interim manager (or any other team member) to primary so that configuration options will be available.

- ❗ **IMPORTANT:** Once you promote the interim manager to primary manager, you **cannot** return the old team manager to the team without changing its configuration so that it becomes a team member. Only one manager is supported per team.

1. Under **Controllers**, select the team manager (which is now the interim manager).

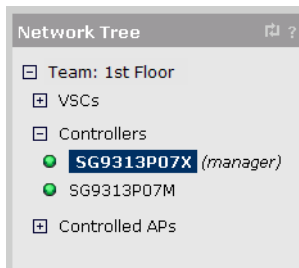

2. In the right pane, select **Management > Teaming**.
3. Enable the **Team manager** option. The settings for this option should already be defined with the values that were set on the primary team manager.

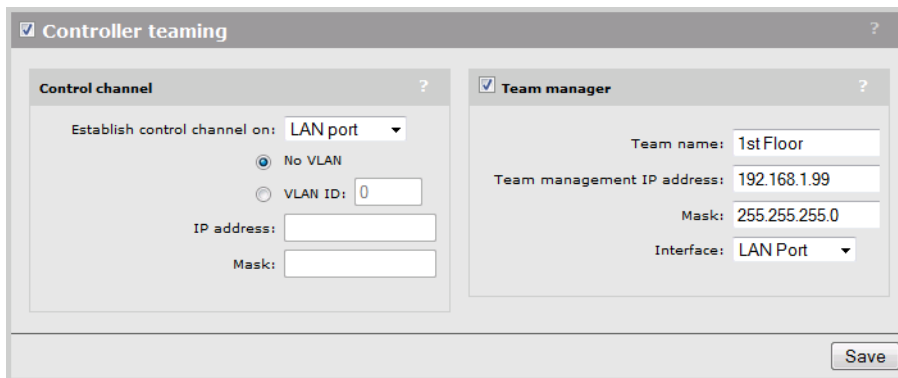

4. Select **Save**.

Mobility support

Mobility support when controller teaming is active is very similar to mobility support on non-teamed controllers. This section discusses the differences and configuration issues involved. For an explanation of mobility concepts used in this section, see [“Mobility traffic manager” \(page 285\)](#).

The key benefit of using a team to provide a mobility solution is support for failover if the primary mobility controller becomes inoperative. The following diagram shows two identical setups, except that one is a team and the other is independent controllers.

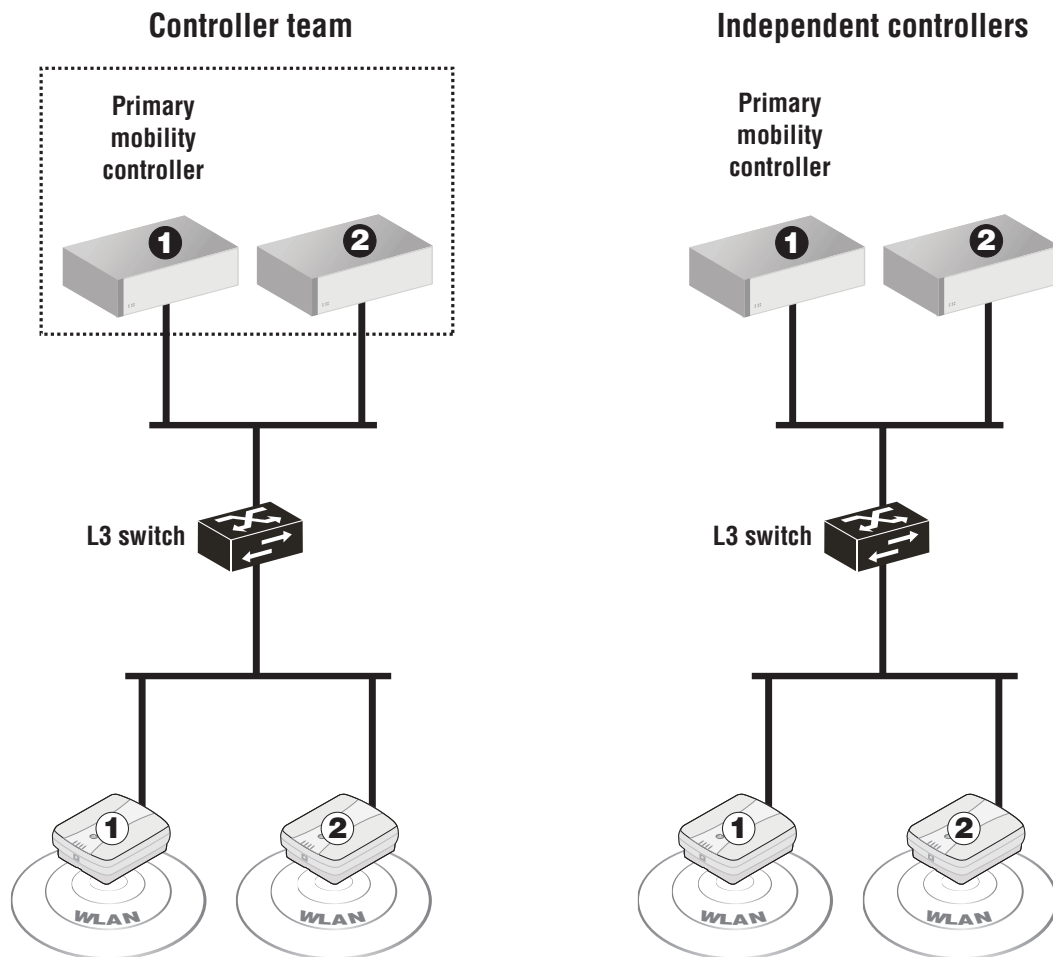

In the controller team, the primary mobility controller is also the team manager. If the team manager becomes inoperable, then controller 2 is automatically promoted to become the interim manager and assumes the role of primary mobility controller as well.

If the primary mobility controller fails in the independent controllers setup, mobility services are interrupted until you manually reconfigure controller 2 as the primary mobility controller.

Single controller team operating alone

If you have a single controller team, the mobility domain is automatically created when you do the following:

1. Start the management tool on the team manager by pointing your browser to the team IP address.
2. Select **Team: [name] >> Management > Device discovery**.
3. Select **Mobility controller discovery**.
4. Select **This is the primary mobility controller**.

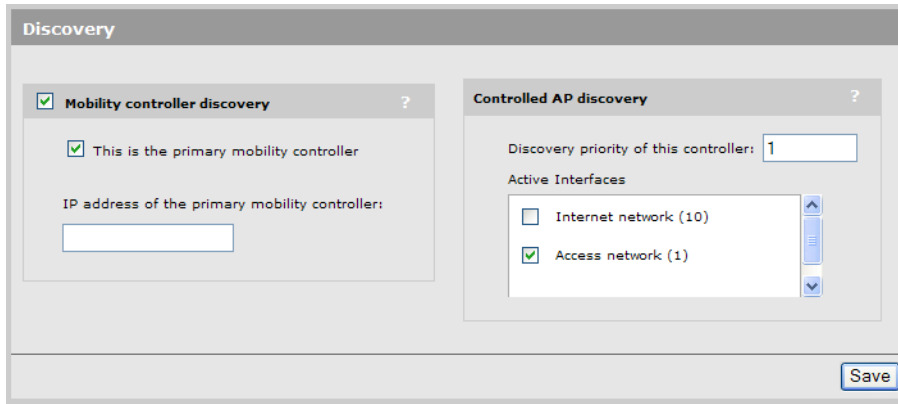

5. Select **Save**.

You can now configure mobility options, such as home networks, as explained in [“Mobility traffic manager”](#) (page 285).

Single controller team operating with non-teamed controllers

In this type of setup, the team is configured as the primary mobility controller and the non-teamed controllers set the **IP address of primary controller** parameter to the team IP address. (In this scenario, the team IP address is defined on the LAN port of the team manager.)

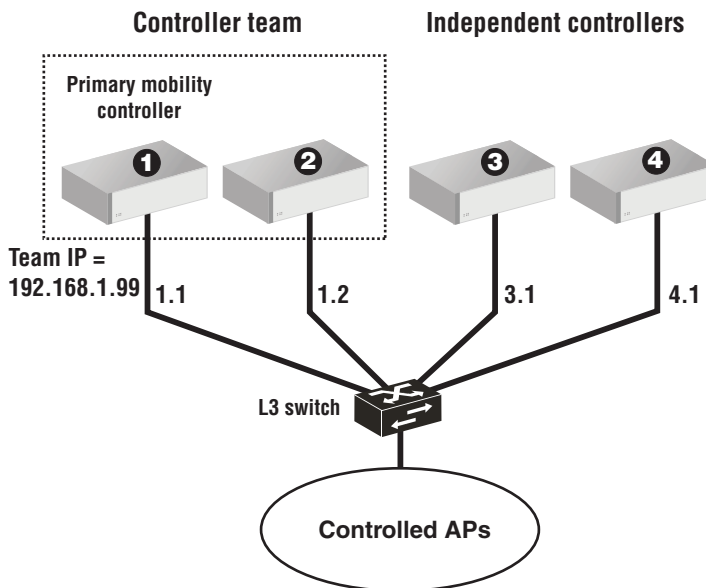

Configure the team

1. Start the management tool on the team manager by pointing your browser to the team IP address.
2. Select **Team: [name] >> Management > Device discovery**.
3. Select **Mobility controller discovery**.
4. Select **This is the primary mobility controller**.

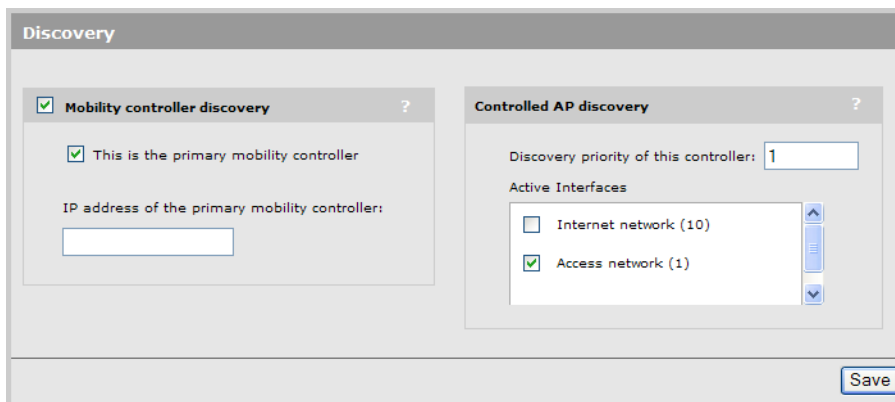

5. Select **Save**.

Configure controller #3 and #4

1. Start the management tool each independent controller by pointing your browser to appropriate IP address.
2. Select **Management > Device discovery**.
3. Select **Mobility controller discovery**.
4. Set **IP address of the primary mobility controller** to **192.168.1.99**.

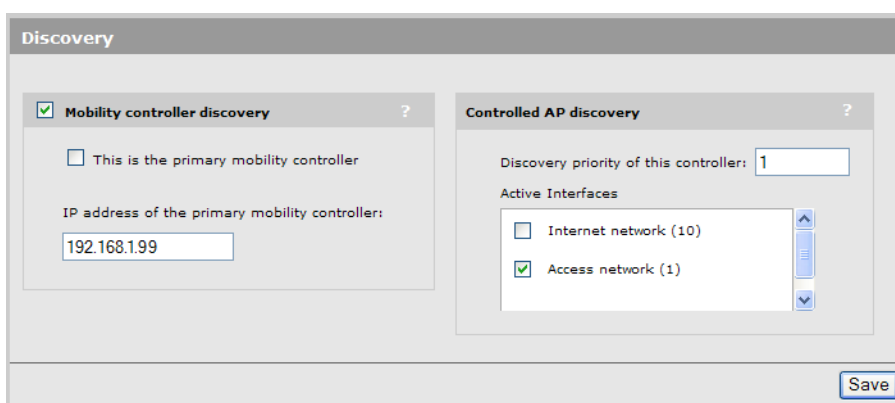

5. Select **Save**.

You can now configure wireless mobility options, as explained in ["Mobility traffic manager"](#) (page 285).

Multiple teamed and non-teamed controllers

If you have multiple teams with or without multiple non-teamed controllers, mobility support is configured as follows: Choose one team as the primary mobility controller. On all other teams/non-teamed controllers set the **IP address of primary mobility controller** parameter to the team IP address of the primary mobility controller.

Guest access and teaming

Caution: When using teaming and deploying a guest access solution, you must not use the **Create a wireless network for guests** workflow. Instead, you must manually configure guest access as described in the section ["Guest access and teaming"](#) (page 276).

The guest access feature (public access interface) provides a way for a controller to act as the gatekeeper between two network segments: a public network connected to the LAN port (Access network on the MSM720), and a protected network connected to the Internet port (Internet network on the MSM720). Access to the public network and its resources is usually made available to all

unauthenticated wireless users once they successfully connect to the wireless network. Access to the protected network is restricted by the controller and typically requires that users be authenticated by the controller before they gain access.

When teaming is enabled, a couple of important factors come into play which impact how guest access can be configured:

- **Use of an external DHCP server is mandatory:** Since the internal DHCP server is *not* supported on a controller team, and client traffic is always sent to the team using the client data tunnel, this forces the use of an external DHCP server and implies that the controller team be configured for DHCP relay.
- **Multiple gateways are introduced:** All teamed controllers are required to operate on the same subnets, which means that there is no longer one choice of gateway to allow proper routing of traffic from client to destination and back.

The following diagram presents an overview of how guest access can be setup with a controller team.

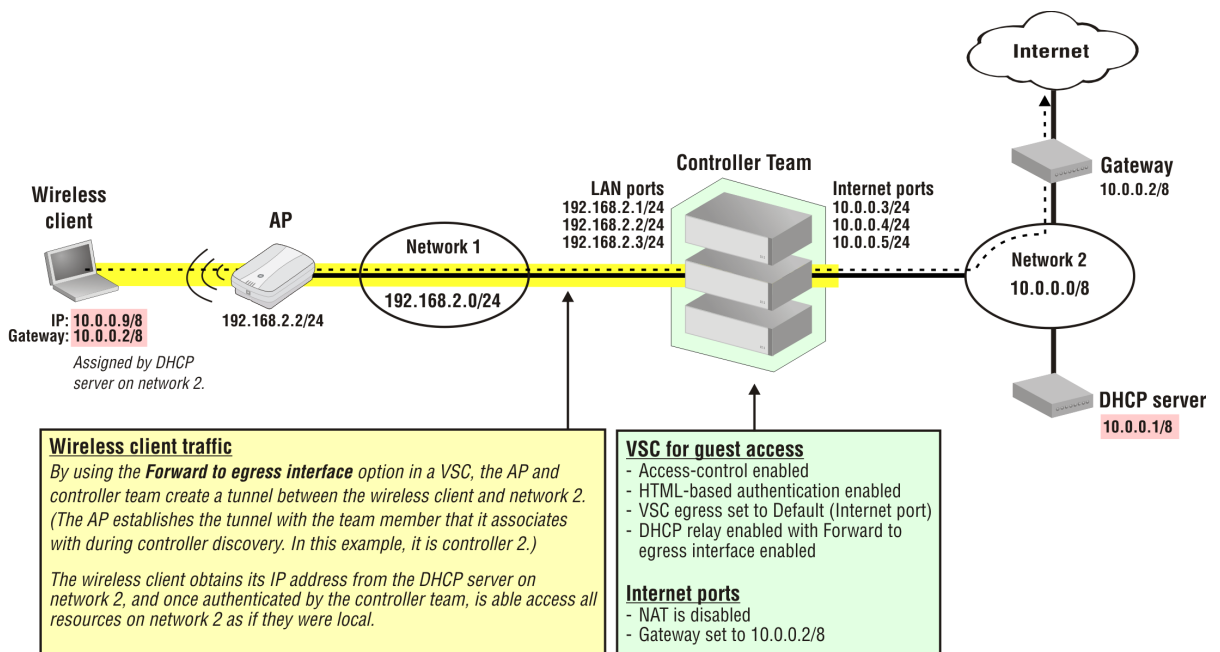

Key configuration settings

To successfully configure support for guest access on a controller team, the following limitations must be respected:

- **DHCP relay agent:** Must be used instead of the internal DHCP server, but only the following options are supported (blue lines mark options that are not supported and should be left blank):

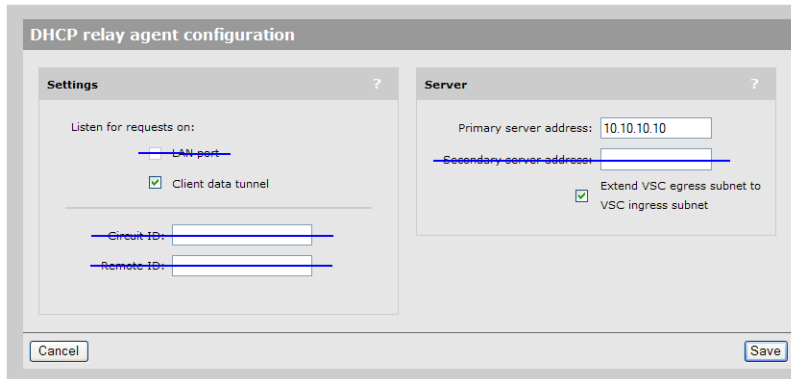

- **Listen for requests on LAN port:** This setting needs to be disabled, as support for relaying DHCP requests for wired clients is not supported. This option is disabled by default. When you enable **Extend VSC egress subnet to VSC ingress subnet**, this option is grayed out and cannot be selected.
 - **Listen for requests on Client data tunnel:** This option must be enabled.
 - **Circuit ID** and **Remote ID:** These settings can be left blank. They are only useful when combined with the standard DHCP relay option which is not supported on a team.
 - **Primary server address:** This needs to be set to a dummy IP address so that the page can be saved. A server address is not needed when the **Extend VSC egress subnet to VSC ingress subnet** option is enabled.
 - **Secondary server address:** This setting can be left blank.
 - **Extend VSC egress subnet to the VSC ingress subnet:** This option must be enabled.
- **Default VSC**

The Default VSC cannot be used for guest access. However, it can be used for other applications, in which case only the following settings are supported:

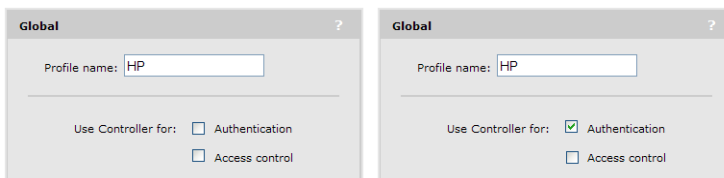

Do not configure the Default VSC as follows:

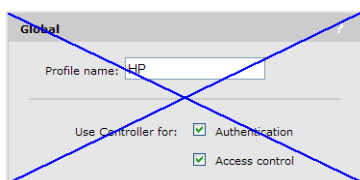

- **Creating a VSC for guest access**

You must create a new VSC to support guest access. Respect the following limitations:

- **VSC egress mapping:** If VLANs are not being used to egress traffic, only the Internet port (Internet network on the MSM720) can be used to provide access to the protected network for authenticated clients. This occurs because the DHCP relay agent option **Forward to egress interface** *always* sends traffic to the Internet port for DHCP requests. This requires setting all options to **<Default>** as shown.

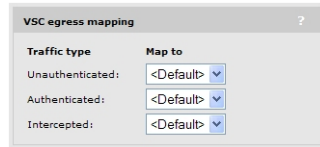

If you are using VLANs, it is still recommended that authenticated traffic is egressed on the Internet port (Internet network on the MSM720) when supporting guest access.

- **DHCP server:** Not supported.
- **DHCP relay agent:** Only supported if configured as follows:

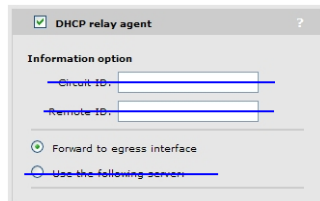

- **Network address translation (NAT):** If traffic is egressed onto the Internet port (Internet network on an MSM720), NAT must be disabled by selecting **Team >> Network > IP interfaces > Internet port (Internet network on an MSM720)**.

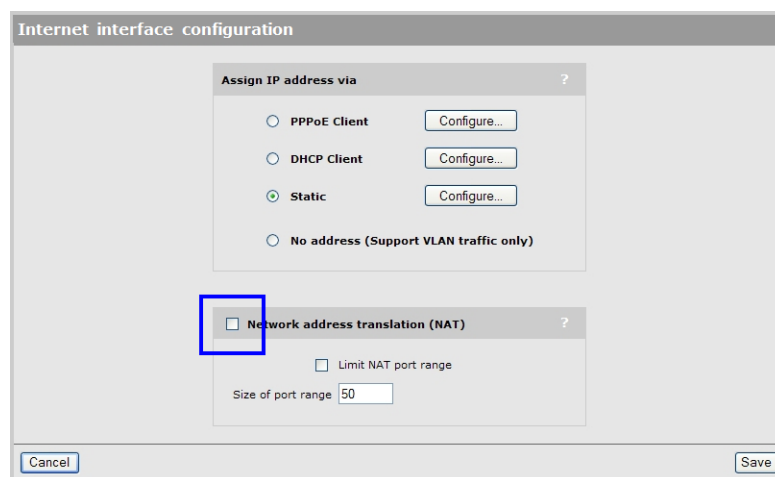

This applies even when using a VLAN to egress traffic, in which case NAT is disabled when defining the interface associated with the VLAN.

The screenshot shows a configuration window titled "Add/Edit interface". It contains three main sections:

- Interface:** A dropdown menu showing "Egress (30)".
- Assign IP address via:** Two radio buttons: "DHCP client" (selected) and "Static". Below "Static" are three input fields for "IP address:", "Mask:", and "Gateway:".
- Network address translation (NAT):** Two radio buttons: "Enabled" and "Disabled" (selected and highlighted with a blue box).

At the bottom of the window are "Cancel" and "Save" buttons.

Guest access with teamed controllers using the same subnet

In this scenario, a pair of controlled APs tunnel user traffic to the LAN ports on a controller team composed of two MSM760s. Once authenticated, users are able to access the Internet via the Internet ports. Both ports (LAN and Internet) are untagged (no VLANs are assigned).

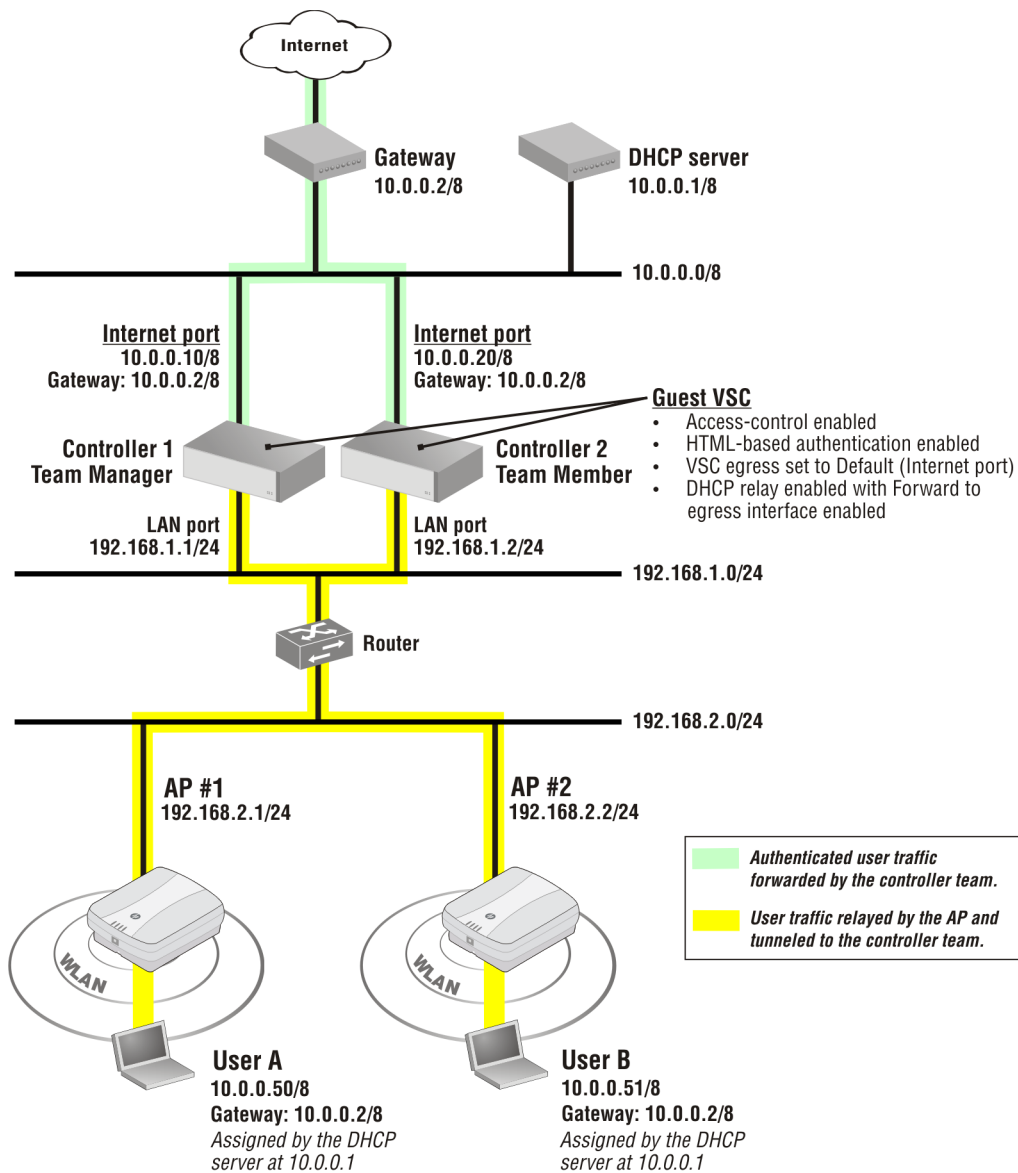

The following steps illustrate how to configure this scenario. (These steps assume that the controller team has already been created, and that the APs have been discovered, are properly synchronized and are ready to accept additional configuration settings.)

Disable NAT on the egress interface

Since the Internet port will be used to egress traffic, NAT needs to be disabled on it.

1. Select **Team >> Network > IP interfaces**.
2. Select **Internet port**. The Internet interface configuration page opens.

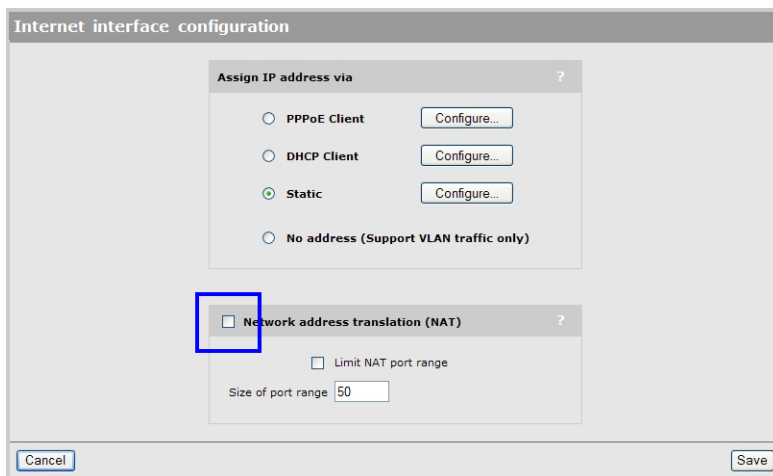

3. Disable **Network address translation (NAT)**.
4. Select **Save**.

Enable DHCP relay globally

In order for wireless client stations to obtain an IP address, the controller must act as a DHCP relay agent to forward requests to the external DHCP server at 10.0.0.1.

1. Select **Team >> Network > Address allocation**. The Address allocation configuration page opens.
2. Select **DHCP relay agent** and then select the **Configure** button next to it.



3. The DHCP relay agent configuration page opens.

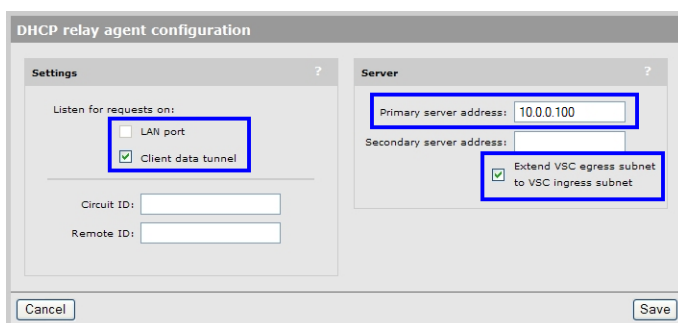

- Under **Listen for requests on**, disable **LAN port** and enable **Client data tunnel**.
- Set **Primary server address** to a dummy IP address.
- Enable the **Extend VSC egress subnet to the VSC ingress subnet** option. (Although this option is only useful when a VLAN is used as the egress on a VSC, HP recommends that it always be enabled.)
- Select **Save**.

Create a new VSC for guest access

The default VSC cannot be used for guest access when teaming is enabled, so a new VSC must be created.

1. Select **VSC >> Add new VSC profile**.
2. The VSC profile page opens. Configure the following settings:
 - Define a name for the VSC and enable **Authentication** and **Access control**.

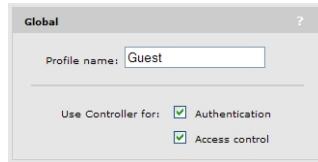

The screenshot shows the 'Global' configuration page for a VSC profile. The 'Profile name' field is set to 'Guest'. Under the 'Use Controller for:' section, both 'Authentication' and 'Access control' checkboxes are checked.

- Define the SSID name for the wireless network.

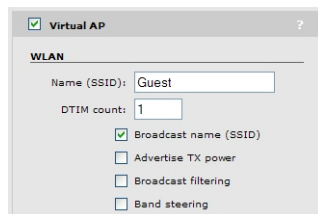

The screenshot shows the 'Virtual AP' configuration page. Under the 'WLAN' section, the 'Name (SSID)' field is set to 'Guest' and the 'DTIM count' is set to '1'. The 'Broadcast name (SSID)' checkbox is checked, while 'Advertise TX power', 'Broadcast filtering', and 'Band steering' are unchecked.

- Enable the **HTML-based user logins** option. (This allows users to log in to the protected network using their web browsers.)

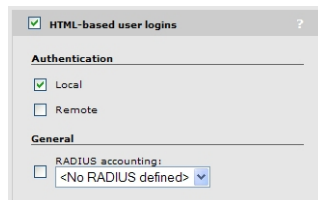

The screenshot shows the 'HTML-based user logins' configuration page. Under the 'Authentication' section, the 'Local' checkbox is checked and 'Remote' is unchecked. Under the 'General' section, the 'RADIUS accounting:' dropdown menu is set to '<No RADIUS defined>'. The 'RADIUS accounting:' checkbox is unchecked.

- Set the **VSC egress mapping** to **<Default>** for all types of traffic since VLANs are not being used. This sends all authenticated traffic out via the Internet port.

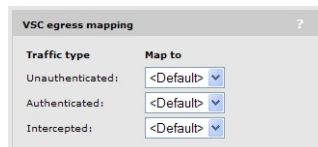

The screenshot shows the 'VSC egress mapping' configuration page. It has a table with two columns: 'Traffic type' and 'Map to'. All three rows are set to '<Default>':

Traffic type	Map to
Unauthenticated:	<Default>
Authenticated:	<Default>
Intercepted:	<Default>

- Enable the **DHCP relay agent** checkbox and select **Forward to egress interface**. (Do not specify a **Circuit ID** or **Remote ID**. These options are not supported when teaming is enabled.)

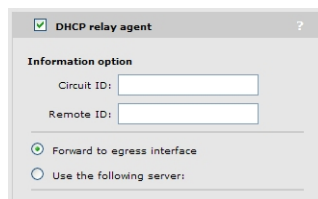

The screenshot shows the 'DHCP relay agent' configuration page. Under the 'Information option' section, the 'Circuit ID' and 'Remote ID' fields are empty. The 'Forward to egress interface' radio button is selected, and 'Use the following server:' is unselected.

3. Select **Save**.

4. Make sure that the VSC is bound to the APs, and that the APs are synchronized.

Now, when a wireless client station connects to the *Guest* SSID, it will obtain an IP address on the subnet assigned to the Internet port via the external DHCP server. Once the wireless client is authenticated, it will gain access to the subnet connected to the Internet port (and by extension, the Internet).

15 Mobility traffic manager

Key concepts

NOTE: This chapter discusses how to use and configure Mobility traffic manager (MTM) with non-teamed controllers. If you are working with a controller team, most of the same information applies. Essentially, a controller team is treated the same way as a single non-teamed controller. For more information, see “[Mobility support](#)” (page 273).

MTM provides for seamless roaming of wireless users, while at the same time giving you complete control over how wireless user traffic is distributed onto the wired networking infrastructure. MTM enables you to implement a wireless networking solution using both centralized and distributed strategies, allowing you to create a wireless network that is perfectly tailored to meet the needs of your users and the requirements of your network. Some of the deployment strategies that you can use with MTM include:

- **Centralized wireless traffic:** All traffic from wireless users is tunneled back to a central controller where it is egressed onto the wired infrastructure. Wireless users can be connected to any AP within the layer 3 network serviced by MTM.

The following diagram shows a deployment, where all wireless traffic is egressed onto a specific network segment: 192.168.30.0. (On an MSM720, replace **LAN port** with **Access network** and **Internet port** with **Internet network** in the following diagram.)

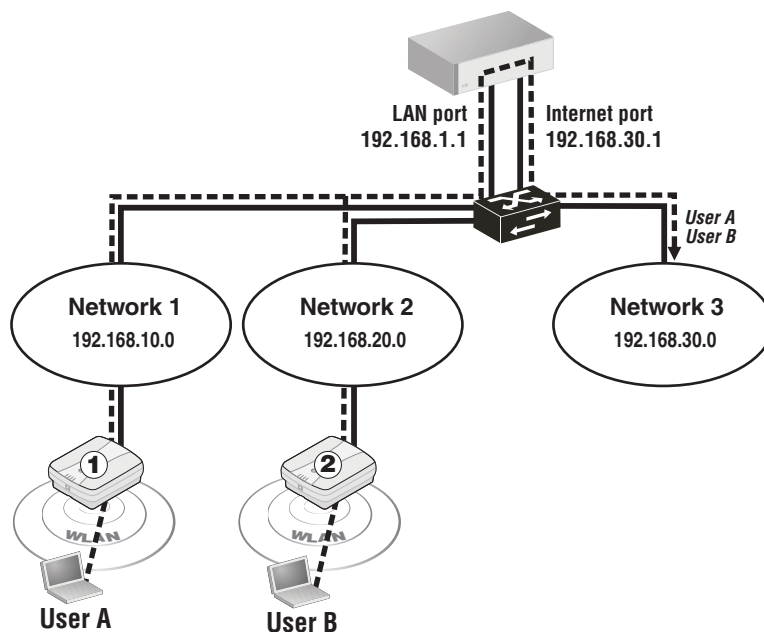

MTM can also be used to send traffic to different networks or VLANs based on criteria such as username, network location, VSC, or AP group.

- **Traffic distribution using home networks:** A home network can be assigned to each wireless user (via RADIUS, local user accounts, or through a VSC egress). MTM can then be used to tunnel the users traffic to their home network, regardless of the AP to which a user connects within the mobility domain.

The following diagram shows a deployment where the wireless traffic for each user is egressed onto a specific network segment by assigning a home network to each user. (On an MSM720, replace **LAN port** with **Access network** and **Internet port** with **Internet network** in the following diagram.)

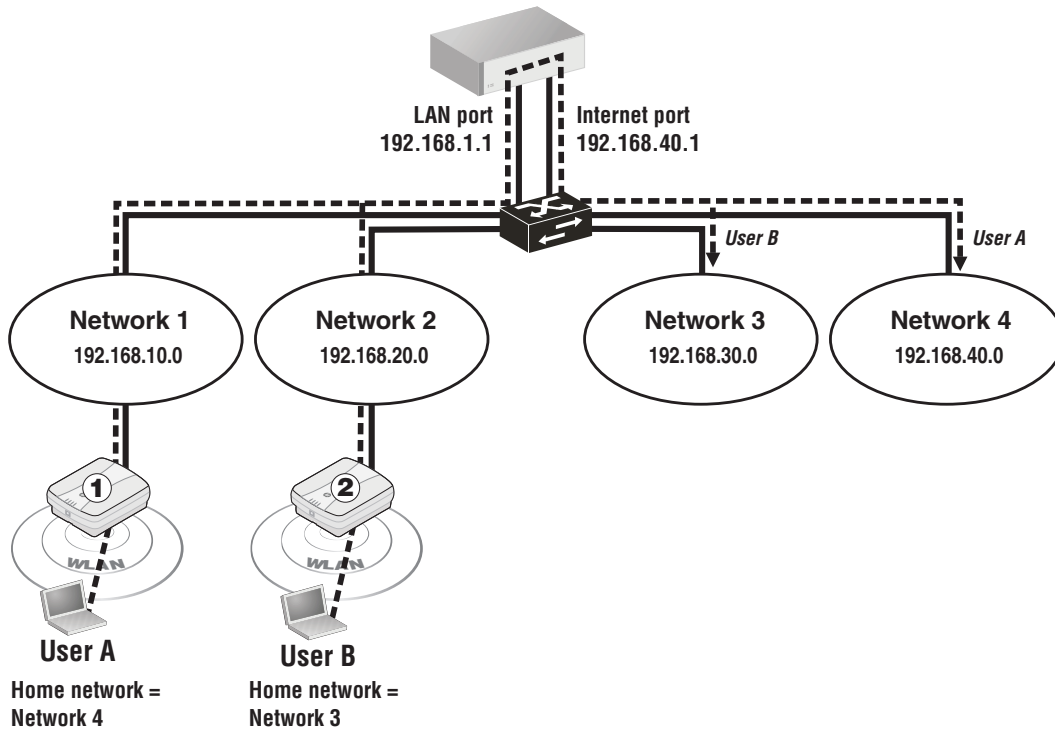

If a user roams between APs, MTM adjusts the tunnel to maintain the users connection to their home network. (On an MSM720, replace **LAN port** with **Access network** and **Internet port** with **Internet network** in the following diagram.)

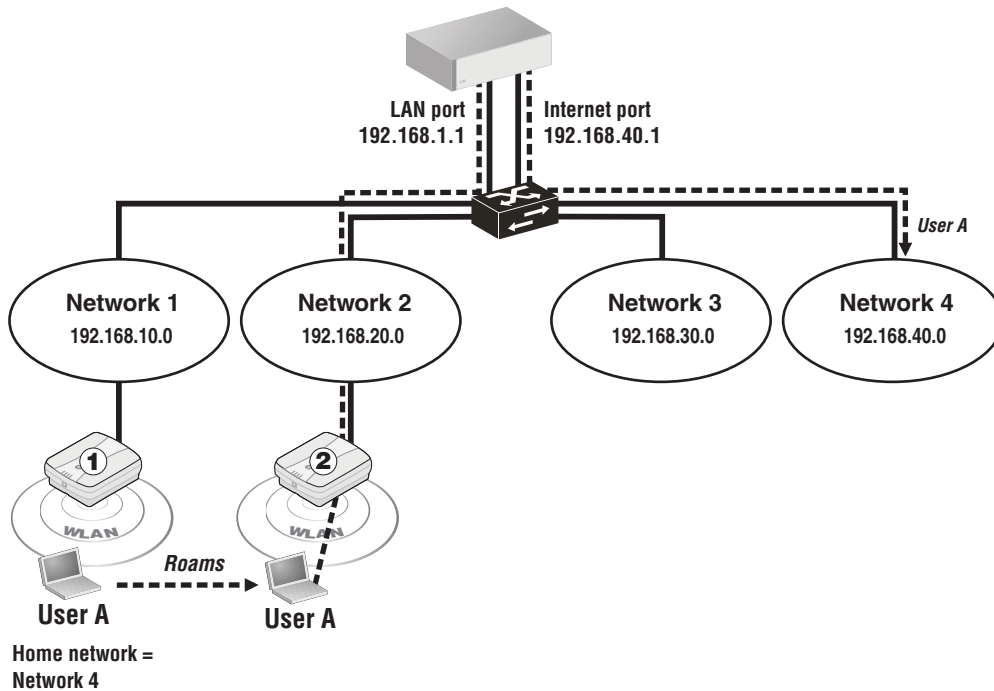

- **Automatic traffic distribution:** VLAN ranges can be used to automatically spread wireless user traffic across multiple VLANs on the wired infrastructure. See [“Scenario 6: Distributing traffic using VLAN ranges”](#) (page 323).



IMPORTANT:

- MTM is only available on non-access-controlled VSCs.
- The same VSCs must be defined on all controllers in the mobility domain, even on controllers that are not managing any APs.

The mobility domain

The mobility domain is an interconnection between controllers allowing for the exchange of information about wireless users and the home/local networks managed by controllers. The mobility domain can span multiple controllers and controller teams, whether they are installed on the same subnet or on different subnets, and includes all controlled APs managed by the controllers.

In the following example the mobility domain spans three controllers and their APs operating on three different subnets. (On an MSM720, replace **LAN port** with **Access network** in the following diagram.)

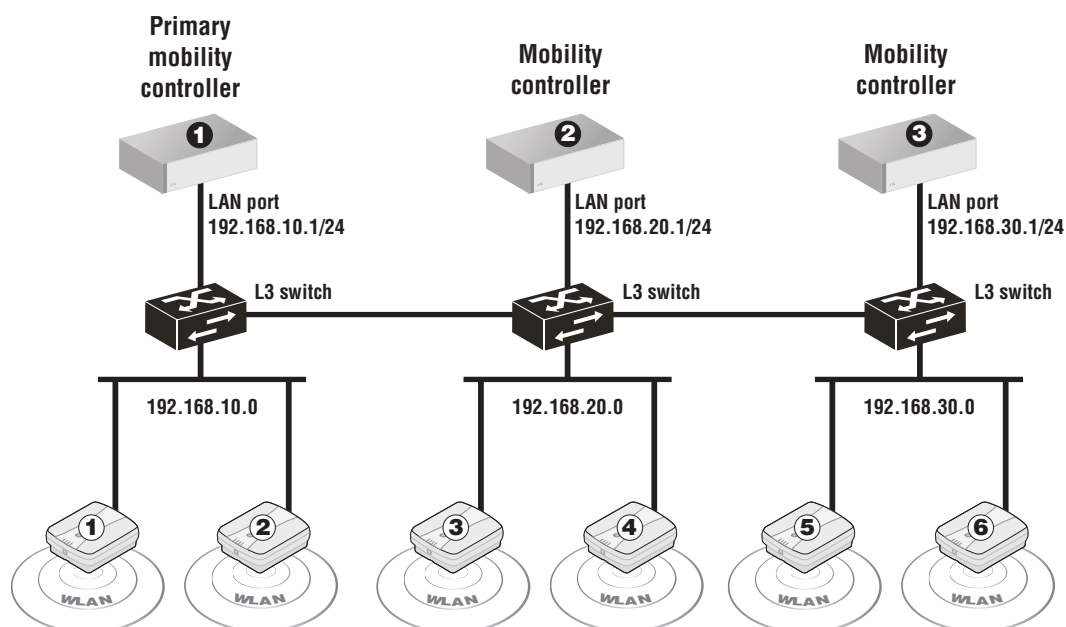

MTM makes use of the mobility domain to locate the home network for roaming users, or the target network when tunneling traffic to a specific network on the wired infrastructure.

For each mobility domain, one controller is defined as the *primary mobility controller*. This controller acts as the central site for the distribution of mobility information to all other controllers. (When controller teaming is active, an entire team is defined as the primary mobility controller. See “[Mobility support](#)” (page 273).)

NOTE:

- All controllers in the mobility domain must be running the same software version. This means that the first two numbers in the software revision must be the same. For example: All controllers running 5.6.x, or all controllers running 5.7.x.
- Discovery automatically takes place on both the LAN port and Internet port. **VLANs are not supported.**

Network requirements

The network that interconnects the controllers and APs that make up a mobility domain must not block any of the following ports/protocols:

- UDP port 1194
- UDP port 12141
- UDP port 3000
- UDP port 3001
- UDP port 3518
- TCP port 5432
- Internet protocol number 47 (GRE)
- NAT must not be used. The IP address of each AP must be visible to the controller.

Home networks

A home network is the root network for a user within a mobility domain. The home network specifies the network on which a users wireless traffic is sent onto the wired infrastructure. A users connection is always local to their home network, regardless of where their wireless connection is made within the mobility domain. For example, if a user roams between an AP that is directly connected to their home network, to an AP on a different subnet, MTM creates a tunnel that connects the user back to their home network.

When a user first connects to an AP, MTM must determine whether the user is *at home* (i.e., connected to the users home network) or *roaming* (connected to an AP on a different network). MTM does this by comparing the home network assigned to the user with the list of local networks associated with the AP.

- If a match is found, the user is considered to be at home and the users traffic is sent onto the wired network via the APs Ethernet port.
- If **no** match is found, MTM then tries to locate the users network within the mobility domain. If found, MTM creates a tunnel between the AP and the controller to carry the user's traffic. If the network is not defined on any controller within the mobility domain, the user is blocked (or assigned to the network on which the AP discovered the controller, depending on how MTM support is configured on the VSC).

NOTE: Certain configuration settings on the controller may override the specific configuration settings that you define on a VSC to assign user traffic to a home network. For details, see [“Traffic flow for wireless users” \(page 221\)](#).

Example

In following example, User A roams between AP # 1 and AP #2. When connected to AP #2, User A is identified as roaming and traffic is tunneled back to subnet 10.0 via controller 1 and controller 2. (On an MSM720, replace **LAN port** with **Access network** in the following diagram.)

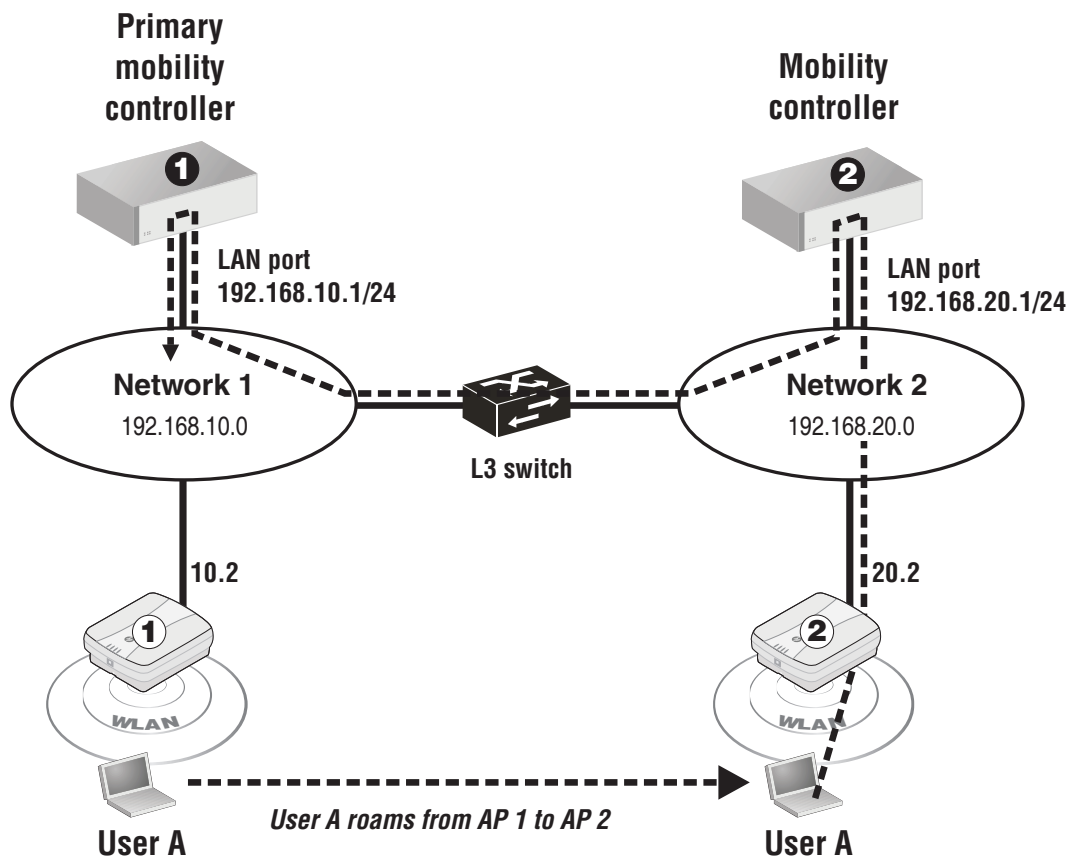

Local networks

In order for a wireless users traffic to be sent to the appropriate destination within the mobility network, local networks must be defined on controllers, and optionally APs.

When a user is roaming, the path to the users home network cannot end at an AP. This means that each home network that is assigned to a user **must** be defined as the local network on at least one controller in the mobility domain.

- When an AP is directly connected to a users home network, the users data will **only** reach the wired network through the APs Ethernet port when the user is directly connected to the AP.
- When roaming, the users traffic is always tunneled to the controller that provides the data path to the users home network.

In the previous example, when User A is directly connected to AP 1, traffic reaches Network 1 via the APs Ethernet port. When User A roams to AP 2, traffic reaches Network 1 via the LAN port on controller 1.

Mobility controller discovery

The wireless mobility feature defines a mobility domain, which is an interconnection between multiple controllers for the purpose of exchanging mobility information on wireless users. For more information, see [“Mobility traffic manager” \(page 285\)](#).

For the controllers to interconnect, each must have the **Mobility controller discovery** option enabled. In addition, one controller must be defined as the primary mobility controller. It acts as the central site for distribution of mobility information.

There can only be one primary controller for each mobility domain. On all other controllers set **IP address of primary controller** to the IP address of the primary controller.

NOTE:

- All controllers in the mobility domain must be running the same software version. This means that the first two numbers in the software revision must be the same. For example: All controllers running 5.4.x, or all controllers running 5.5.x.
 - Discovery automatically takes place on both the LAN port and Internet port (Access network and Internet network on the MSM720). **VLANs are not supported. (Meaning the ports on the MSM720 must be untagged.)**
-

Network requirements

The network that interconnects the controllers and APs that make up a mobility domain must not block any of the following ports/protocols:

- UDP port 1194
- UDP port 12141
- UDP port 3000
- UDP port 3001
- UDP port 3518
- TCP port 5432
- Internet protocol number 47 (GRE)

Controller discovery and teaming

When teaming is active, several configuration scenarios are possible:

- **Teamed controllers operating in conjunction with one or more non-teamed controllers:** Set the team as the primary mobility controller. On the other controllers, set the **IP address of primary mobility controller** parameter to the team IP address.
- **A single team of controllers:** Enable the **This is the primary mobility controller** option on the team manager.
- **Multiple teamed and non-teamed controllers:** Set one team as the primary mobility controller. On the other teams and controllers, set the **IP address of primary mobility controller** parameter to the team IP address of the primary mobility controller.

This is the primary mobility controller

Enable this option to designate this controller as the primary mobility controller. The primary controller is responsible for the coordination and discovery of all other controllers in the mobility domain.

IP address of primary mobility controller

Enter the IP address of the primary mobility controller.

Configuring Mobility Traffic Manager

MTM configuration can be separated into the following tasks:

- Define the mobility domain.
- Define network profiles.
- Assign home networks to users.
- Define local networks on controllers and APs.

- Configure mobility settings for each VSC. (*The same VSCs must be defined on all controllers in the mobility domain, even on controllers that are not managing any APs.*)
- Bind VSCs to the APs.

Each task is described in more detail in the sections that follow.

Defining the mobility domain

When MTM will be used on more than one controller, or with a controller team, you must define a mobility domain. The following instructions apply to non-teamed controllers. If you are working with a controller team, see [“Mobility support” \(page 273\)](#).

Connect to the management tool on the controller that will be the primary mobility controller, and do the following:

1. Select **Controller >> Management > Device discovery**.
 - Select **Mobility controller discovery**.
 - Select **This is the primary mobility controller**.

On the MSM720

On other controllers

2. Select **Save**.

Connect to the management tool on all other controllers, that will be part of the mobility domain and do the following:

1. Select **Controller >> Management > Device discovery**.
2. Select **Mobility controller discovery**.
3. Specify the **IP address of the primary mobility controller**. This can be the address of any port as long as the port is reachable. For example, if the primary is at 192.168.5.1, you would configure the other controllers as follows:

On the MSM720

Discovery

Mobility controller discovery ?

This is the primary mobility controller

IP address of the primary mobility controller:

Controlled AP discovery ?

Discovery priority of this controller:

Active Interfaces

Internet network (10)

Access network (1)

On other controllers

Discovery

Mobility controller discovery ?

This is the primary mobility controller

IP address of the primary mobility controller:

Controlled AP discovery ?

Discovery priority of this controller:

Active Interfaces

LAN Interface

Internet Interface

4. Select **Save**.

Defining network profiles

Global definitions for all home networks and local networks are created using the network profiles feature which is found on the **Controller >> Network > Network profiles** page ([“About the default network profiles”](#) (page 32)).

Assigning a home network to a user

When you activate MTM support for a VSC, a user's home network is defined in one of the following ways:

- It can be configured in the users account on a third-party RADIUS server by setting the attributes **Tunnel-Medium-Type**, **Tunnel-Private-Group-ID**, and **Tunnel-Type**. For details on how to set these attributes, see [“User attributes”](#) (page 443).
 The **Tunnel-Private-Group-ID** attribute should be set to the name of the network profile that identifies the users home network (A VLAN number can also be specified, but is not recommended since two profiles could exist with the same VLAN ID but bound to different physical ports or VLAN ports.)
- Configured in a locally defined user account or user account profile. (User accounts are defined by selecting **Controller >> Users**.) Currently this method only supports VLAN ID. To specify a network profile name, Use the Custom attributes option in a network profile to specify the attributes **Tunnel-Medium-Type**, **Tunnel-Private-Group-ID**, and **Tunnel-Type**.
- Configured by setting the **Egress network** option when binding the VSC to an AP group. This lets you assign the same home network to a group of APs. Any user connected to one of these APs then gets the specified home network. Note that if both the Egress network and a RADIUS attribute are assigned, the Egress network is overwritten by the RADIUS attribute.

A number of configuration settings on the controller can affect how user traffic is routed. Some of these settings may override the choices you make to assign user traffic to a home network. See [“Traffic flow for wireless users”](#) (page 221).

NOTE: At least one controller must be assigned to each home network defined in the mobility domain. See [“Local networks”](#) (page 289).

Defining local networks on a controller

Local networks on a controller are composed of the following interfaces:

- The network connected to the LAN port. Identified by the network profile **Access network** on the MSM720, and **LAN port network** on other controllers.
- The network connected to the Internet port. Identified by the network profile **Internet network** on the MSM720, and **Internet port network** on other controllers.
- Any network profile that has a VLAN ID and is mapped to a port on the **Controller >> Network > VLANs** page.

Assigning local networks to an AP

Each AP can be configured to support one (or more) local networks. By comparing the home network assigned to a user with the list of local networks associated with an AP, MTM can determine if the user is at home or roaming.

Local networks can be assigned by selecting one of the following (depending on whether you want to define local networks for all APs, a group of APs, or a single AP):

- **Controller > Controlled APs >> Configuration > Local networks**
- **Controller > Controlled APs > [group] >> Configuration > Local networks**
- **Controller > Controlled APs > [AP] >> Configuration > Local networks**

In all cases you will see the Home networks configuration page.

On the MSM720

Base Group: All | Local networks

Local networks ?

Available networks: Internet network, Access network

Local networks:

Subnets ?

List of home subnets:

VLAN ID: IP Subnet: IP Netmask: Add

Remove Selected Entry

Save

On other controllers

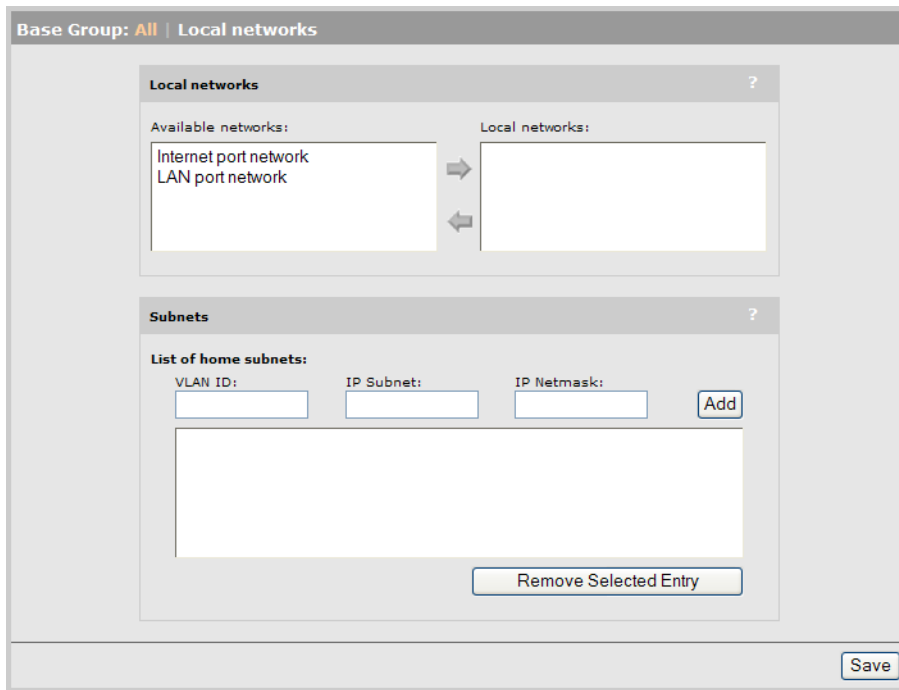

Local networks

Select the local networks that are connected to the Ethernet port(s) on the AP.

- **Available networks:** This box lists all network profiles defined on the controller. Select a network profile and then select the right arrow to assign it as a local network on the AP.
- **Local networks:** This box lists all the networks that are local to the AP. These networks are used to determine if a user is roaming or at home when they connect to the AP.
 - If a users home network matches a local network on the AP, the user is considered to be at home, and their traffic is bridged onto the wired network via the Ethernet port on the AP.
 - If a users home network does not match a local network on the AP, the user is considered to be roaming, and their traffic is tunneled to appropriate home network via the controllers that make up the mobility domain.

NOTE: The Subnets feature has been deprecated. See [“Subnet-based mobility” \(page 330\)](#) for more information.

Configuring the mobility settings for a VSC

Once all home and local networks have been assigned, you can configure VSC definitions to support MTM.

1. Select the **Controller > VSCs > [VSC-name]**.
2. Disable the **Access control** option under **Global**.
3. Select **Wireless mobility**, and under it, select **Mobility traffic manager**.

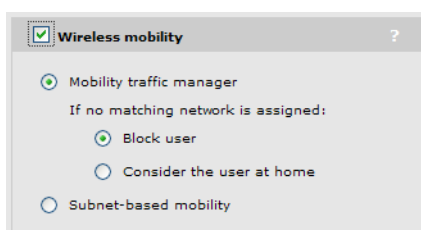

If you are using MTM to tunnel the traffic from wireless users to their home networks, set the following parameter to determine how MTM routes traffic if no home network is assigned to a user (via their RADIUS account or local user account), or if the users home network is not found in the mobility domain.

If no matching network is assigned

- **Block user:** User access is blocked.
 - **Consider the user at home:** The users home network is considered to be the network assigned to the APs Ethernet port and traffic is bridged locally by the AP.
4. Configure the **Wireless security filters** so that they do not interfere with roaming functionality. In most cases, these filters should be disabled. If you need to use them, note that:
 - The **Restrict wireless traffic to: Custom** option can be used provided that it restricts traffic to destinations that are reachable from all subnets in the mobility domain.
 - Neither the **Restrict wireless traffic to: Access points default gateway** nor **Restrict wireless traffic to: MAC address** options can be used.
 5. Select **Save**.

Binding a VSC to an AP

After you have defined a VSC, you need to bind it to all the APs in the mobility domain.

- Select **Controller > Controlled APs > [group] >> VSC bindings** and then the VSC configured for mobility. The VSC binding page opens.

The screenshot shows a configuration window titled "Group: Default Group | VSC binding". It contains several sections:

- VSC Profile:** A dropdown menu for "VSC Profile" is set to "HP".
- Dual-radio behavior:** A section with the text "On multiple radio products VSC is active on:" and a dropdown menu set to "Both radios".
- Egress network:** A checkbox labeled "Egress network" is unchecked. Below it, a dropdown menu for "Network profile" is set to "None".
- Location-aware group:** A text input field for "Group name" contains "Default Group".

At the bottom of the window are "Cancel" and "Save" buttons.

For **VSC profile**, select the VSC that you just configured for mobility.

You have the option of assigning an **Egress network** to the binding. When mobility is active on the VSC, the **Egress network** is assigned as the users home network (unless a dynamic VLAN is assigned to the user).

A number of configuration settings on the controller can affect how user traffic is routed. Some of these settings may override the choices you make to assign user traffic to a home network. See ["Traffic flow for wireless users" \(page 221\)](#).

Monitoring the mobility domain

The mobility overview page displays status information for the mobility domain. For example:

Mobility overview						
Controllers						
Name	IP address	MAC address				
SG843YX002	172.16.0.9	00:1B:3F:87:E3:F8				
SG9333P004	172.16.0.7	00:1B:3F:87:83:FE				
Networks in the mobility domain						
IP subnet	Mask	VLAN ID	Handler	Network		
N/A	N/A	0	This controller	Internet port network		
N/A	N/A	0	This controller	LAN port network		
N/A	N/A	520	This controller	Mobile-network		
Mobility clients						
MAC address	IP address	Data path	Network	Status		
00:24:D7:16:1A:48	192.168.20.246	<ul style="list-style-type: none"> ● CN0ZDLM02P ● SG9363P011 	Mobile-network (520)	Connected		
Forwarding table						
Port	MAC address	VCS ID	VLAN	Authorized	Local	Aging
LAN port	00:03:52:09:84:2A	1	-	Yes	No	1380ms
LAN port	00:03:52:08:0C:47	-	-	Yes	Yes	0ms
Data tunnel	00:21:6A:A2:F4:C8	1	2000	Yes	No	269050ms
LAN port	00:24:A8:1A:3A:A0	1	-	Yes	No	5230ms

To view this page:

- On a non-teamed controller, select **Controller >> Status > Mobility**.
- On a controller team, select **Team:[Team-name] > Controllers [Team-manager] >> Status > Mobility**.

Controllers

This table lists all controllers that are part of the mobility domain.

- **Name:** Name assigned to the controller.
- **IP address:** IP address of the controller.
- **MAC address:** Medium access control address of the associated controller.

Networks in the mobility domain

This table lists all networks that are defined in the mobility domain and indicates the address of the **Handler** (AP or controller) that provides the data path to each network.

This list should be identical on all controllers that are part of the mobility domain. The handler will differ on each controller, depending on whether the network is supported locally or not.

IP subnet

(This field does not apply when using Mobility Traffic Manager.)

IP subnet assigned to the network, if applicable. For example, if the network is a VLAN, then no IP subnet/mask information is shown.

Mask

Network mask associated with the IP subnet, if applicable.

VLAN ID

VLAN ID associated with the network.

Handler

A handler is the AP or controller that provides the data path to a network.

- If the network is handled by an AP managed by this controller, then this column shows the names of controlled APs supporting the network. Up to five APs can be displayed (the first five APs registered by the controller for the specific network).
- If the network is local to this controller, then this column shows **This controller**.
- If the network is directly connected to another controller, then this column shows the name of the other controller.

Network

Name of the network.

Mobility clients

This table provides information on all roaming clients that are active in the mobility domain.

MAC address

Media access control (hardware) address of the client. Select the address to see a log of mobility-related events for the client. For details, see [“Mobility client event log” \(page 298\)](#).

IP address

IP address of the client.

Data path

Lists all the APs and controllers that are in the data path between a user and their home network.

Network

The name of the users home network.

Status

Possible values are:

- **Connected:** The client is connected to their home network.
- **Blocked:** Client data transfer is blocked because the home network could not be found.

Forwarding table

Port

Identifies the logical or physical port on which traffic is being forwarded.

MAC address

Identifies the MAC address to be matched. Traffic addressed to this address is forwarded on the corresponding port.

VSC ID

Identifies the VSC that a wireless client is connected to.

VLAN

Identifies the VLAN that the MAC address is associated with.

Authorized?

Indicates if the wireless client is authorized to send traffic on the bridge.

Local

- Yes: Indicates that the MAC address identifies an interface on the controller.
- No: Indicates that the MAC address is learned (not on the controller).

Aging

Indicates how long (in seconds) until the entry is deleted from the table. Once deleted the entry must be relearned.

Mobility client event log

This page lists all events for a roaming client.

Date & Time	Category	Operation	Status
2010-10-22 14:59:11	Mobility	Mobility Setup	Mobile Client Connected to Home Network [event repeated 2 times]
2010-10-22 14:59:11	Mobility	Mobility Setup	Client roamed to another BSSID
2010-10-22 14:59:11	Mobility	Mobility Setup	Client updated VSC/VLAN/Network
2010-10-22 14:58:22	Mobility	Mobility Setup	Mobile Client Connected to Home Network [event repeated 2 times]
2010-10-22 14:58:20	Mobility	Mobility Setup	Client roamed to another BSSID
2010-10-22 14:58:20	Mobility	Mobility Setup	Client updated VSC/VLAN/Network
2010-10-22 14:58:20	Mobility	Mobility Setup	Mobile Client Connected to Home Network
2010-10-22 14:58:20	Mobility	Mobility Setup	Client roamed to another BSSID
2010-10-22 14:58:20	Mobility	Mobility Setup	Client updated VSC/VLAN/Network
2010-10-22 14:57:54	Mobility	Mobility Setup	Mobile Client Connected to Home Network [event repeated 2 times]
2010-10-22 14:57:51	Mobility	Client Tunneling	Client Unicast Tunneling On: 192.168.20.241
2010-10-22 14:57:51	Mobility	Client Tunneling	Client Broadcast Tunneling On: 192.168.20.241
2010-10-22 14:57:51	Mobility	Mobility Setup	Mobility Initiated at Home Interface
2010-10-22 14:57:50	Mobility	Mobility Setup	Client roamed to another BSSID
2010-10-22 14:57:50	Mobility	Mobility Setup	Client updated VSC/VLAN/Network
2010-10-22 13:55:06	Mobility	Mobility Setup	Mobility Terminated at Client Interface
2010-10-22 13:55:06	Mobility	Mobility Setup	Client roamed to another BSSID
2010-10-22 13:55:06	Mobility	Mobility Setup	Client updated VSC/VLAN/Network

Date and time

Date and time that the even occurred.

Category

Always set to **Mobility**.

Operation

Possible values are:

- **Client tunneling:** Client tunneling events indicate activities related to establishing the data tunnel to a remote controller or AP for the purposes of transporting client data to its home network.
- **Mobility setup:** Mobility setup events indicate activities related to the detection and status of mobile clients, such as association, de-association, and state changes.

Status

Possible values are:

- **Client Unicast Tunneling On:** The unicast tunneling path to the indicated device (AP or another controller) has been established.
- **Client Broadcast Tunneling On:** The multicast/broadcast tunneling path to the indicated device (either AP or another controller) has been established.
- **Client Unicast Tunneling Off:** The unicast tunneling path to the indicated device (either AP or another controller) has been removed. This is normally done only when the client has disassociated or its home network has changed.
- **Client Broadcast Tunneling Off:** The multicast/broadcast tunneling path to the indicated device (either AP or another controller) has been removed. This is normally done only when the client has disassociated or its home network has changed.
- **Mobile Client Connected from Local Network:** The tunneling path for data sent from the wireless client has been established.
- **Mobile Client Connected to Home Network:** The tunneling path at the clients home network egress point has been established.

- **Mobility Initiated at Home Interface:** A request to setup a client connection at its home network has been received.
- **Mobile Terminated at Home Interface:** A client connection at its home network has been terminated. This normally happens only when the client has disconnected or the network path to its connection point has been disrupted.
- **Mobility Initiated at Client Interface:** A request to setup a client connection at its connection point (the AP where the client is associated) has been received.
- **Mobility Terminated at Client Interface:** A client connection at its connection point has been terminated. This normally happens only when the client has disconnected or the network path to its home network has been disrupted.
- **Client roamed to another BSSID:** A client for which a tunneling path has been established has roamed to another AP. In this case, the tunneling path from its previous AP to its home network is disconnected, and a tunneling path from its new AP to its home network is established.
- **Client updated VSC/VLAN/Network:** A client for which a tunneling path has been established has reconnected to a network and as a result has a new home network assignment. In this case, the tunneling path to its previous home network is disconnected, and a tunneling path to its new home network is established.
- **No AP available to terminate client traffic:** A home network terminated by an AP is not currently available to egress the client traffic. In this case, data from the client will be blocked until the home network (i.e., the AP) becomes available.

Scenario 1: Centralizing traffic on a controller

This scenario illustrates how to centralize the traffic from a VSC that is deployed on several APs on different subnets. (On an MSM720, replace **LAN port** with **Access network** in the following descriptions.)

How it works

In this scenario, a single controller manages several APs deployed on different subnets. The default VSC (named HP) is assigned to each AP and is used to provide wireless services for users. All traffic on this VSC is tunneled to the controller by MTM, where it is egressed onto the wired network. To accomplish this, the egress network in the VSC binding is set to the network profile that is assigned to the controller LAN port.

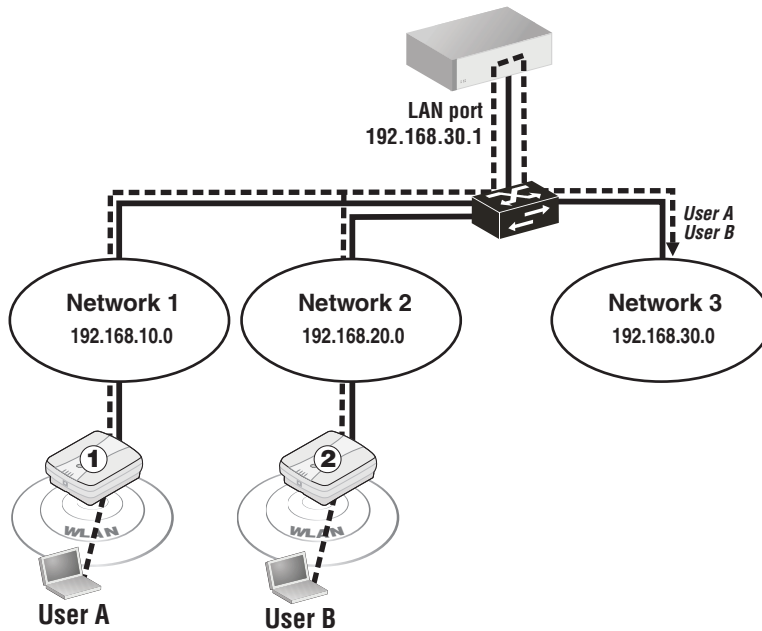

Configuration overview

The following sections provide a summary of the settings needed to configure MTM support for this scenario.

VSC configuration

Enable MTM support on the VSC.

1. Select **Controller >> VSCs > HP**.
 - Under **Global**, clear **Access control**.

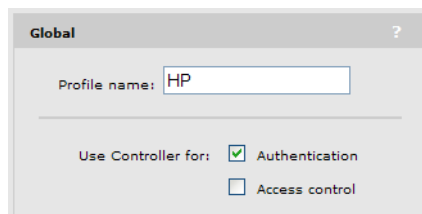

(For a complete screenshot of this page, see [“VSC configuration options”](#) (page 113).)

- Select **Wireless mobility**, then under it:
- Select **Mobility traffic manager**.
- Select **Block user**.

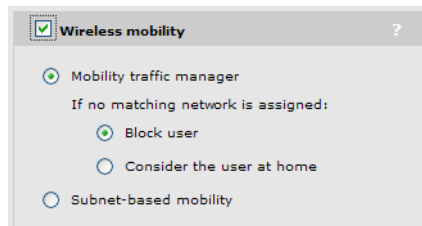

(For a complete screenshot of this page, see [“VSC configuration options”](#) (page 113).)

2. Select **Save**.

Network profiles

This scenario uses the default network profiles, so no configuration is necessary.

VSC binding

This scenario assumes that all APs are part of the **Default Group**. Set the egress for the group to the Internet port on the controller.

1. Select **Controller > Controlled APs > Default Group >> VSC bindings** and then select **HP**. The **VSC binding** page appears.

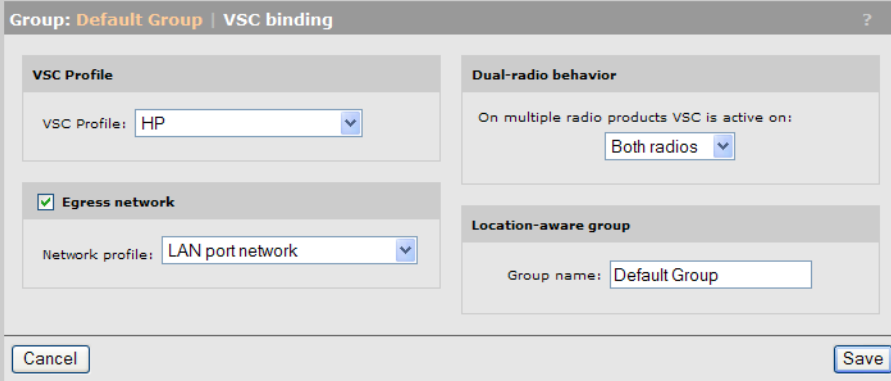

The screenshot shows the 'VSC binding' configuration page for the 'Default Group'. The page is divided into several sections:

- VSC Profile:** A dropdown menu is set to 'HP'.
- Dual-radio behavior:** A dropdown menu is set to 'Both radios'.
- Egress network:** A checkbox is checked, and a dropdown menu is set to 'LAN port network'.
- Location-aware group:** A text field is set to 'Default Group'.

At the bottom of the page, there are 'Cancel' and 'Save' buttons.

- Under **VSC Profile**, set **VSC profile** to **HP**.
 - Select **Egress network**, and under it, set **Network profile** to **LAN port network**.
2. Select **Save**.

Scenario 2: Centralized traffic on a controller with VLAN egress

This scenario illustrates how to centralize the traffic from a VSC that is deployed on several APs on different subnets and send it to one or more VLANs via the controller. (On an MSM720, replace **LAN port** with **Access network** and **Internet port** with **Internet network** in the following descriptions.)

How it works

In this scenario, a single controller manages several APs deployed on different subnets. The default VSC (named HP) is assigned to each AP and is used to provide wireless services for users. All traffic on this VSC is tunneled to the controller by MTM, where it is egressed onto the wired network on VLAN 40. To accomplish this, the egress network in the VSC binding is set to a network profile that defines a VLAN on the controller Internet port.

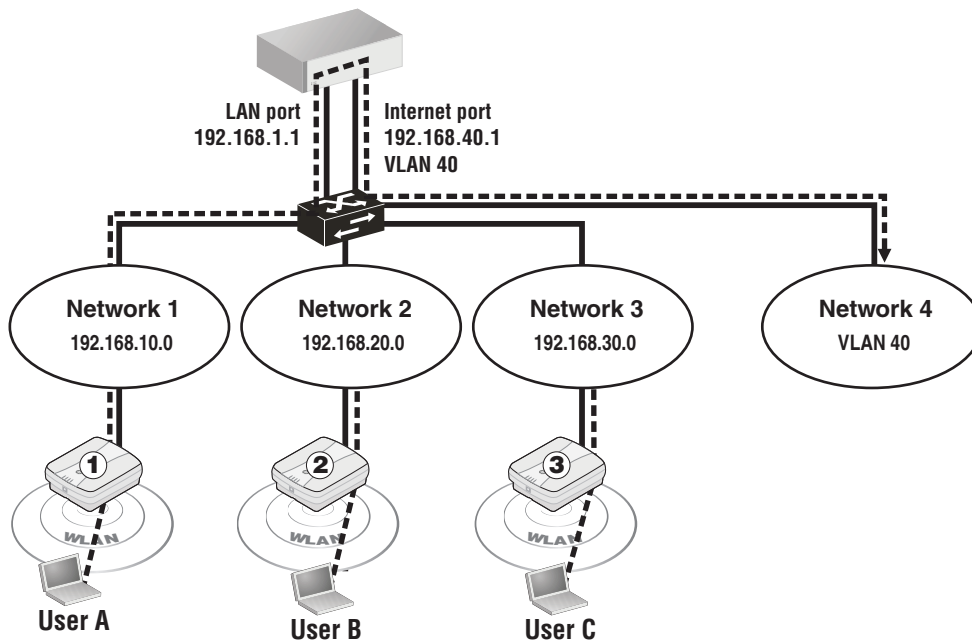

Configuration overview

The following sections provide a summary of the settings needed to configure MTM support for this scenario.

VSC configuration

Enable MTM support on the VSC.

1. Select **Controller > VSCs > HP**.
 - Under **Global**, clear **Access control**.

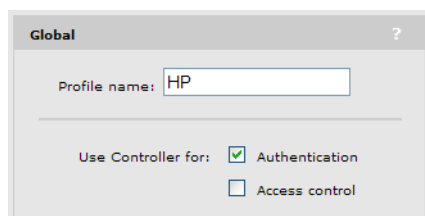

(For a complete screenshot of this page, see [“VSC configuration options”](#) (page 113).)

- Select **Wireless mobility**, then under it:
- Select **Mobility traffic manager**.
- Select **Block user**.

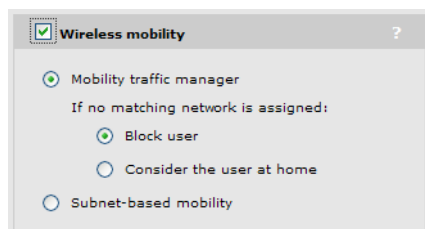

(For complete screenshot see [“VSC configuration options”](#) (page 113).)

2. Select **Save**.

Network profiles

Define a network profile with a VLAN ID of 40.

1. Select **Controller >> Network > Network profiles**.

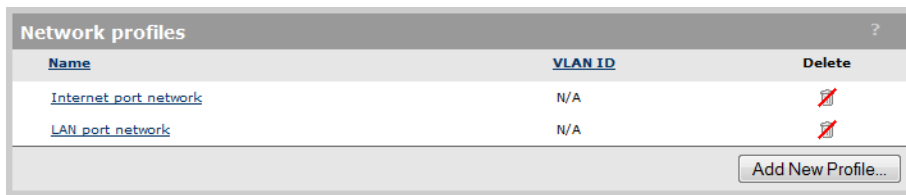

2. Select **Add New Profile**.
3. Under **Settings**, set **Name** to **All-Traffic**.
4. Select the **VLAN ID** checkbox, and specify a value of **40**.

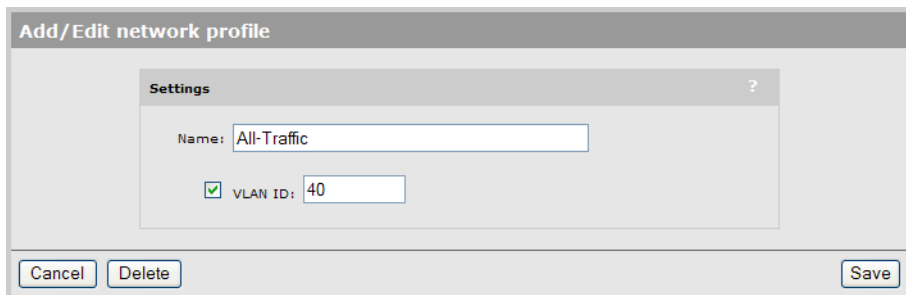

5. Select **Save**.

Map the profile to a port

Map the profile to the **Internet port**.

1. Select **Controller >> Network > VLANs**.

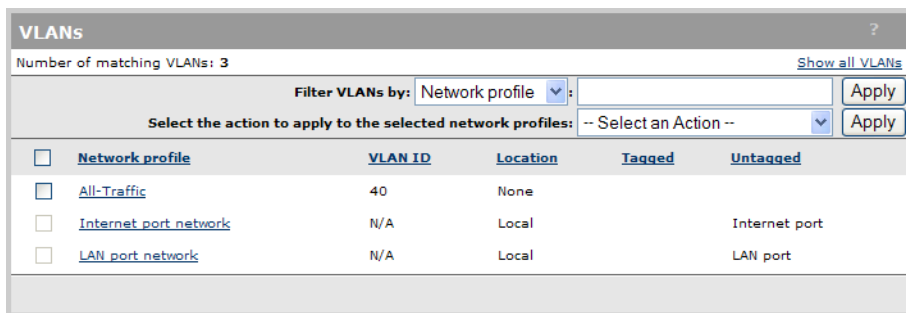

2. Select **All-Traffic** in the table. The Add/Edit VLAN mapping page opens.

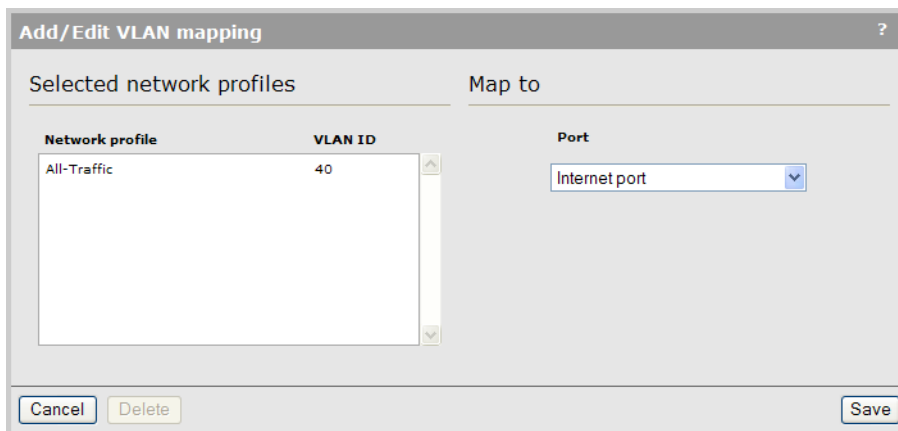

3. Under **Map To**, select **Internet port**.
4. Select **Save**.

VSC binding

This scenario assumes that all APs are part of the **Default Group**.

1. Select **Controlled APs > Default Group >> VSC bindings** and then select **HP**. The **VSC binding** page appears.

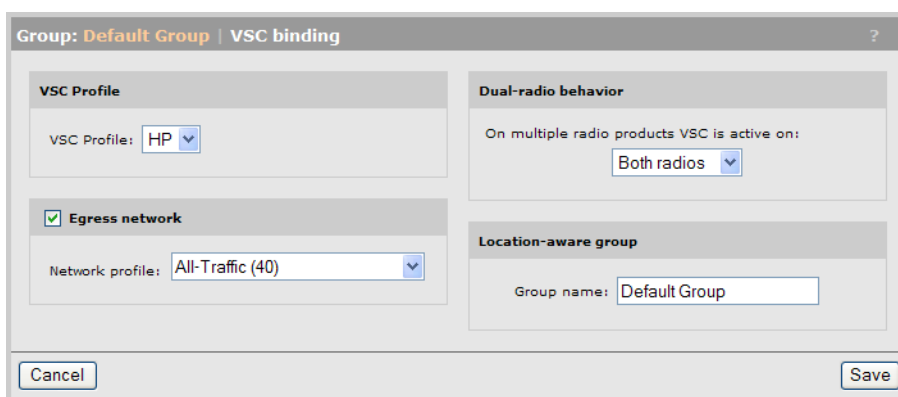

- Under **VSC Profile**, set **VSC profile** to **HP**.
 - Select **Egress network**, and under it set **Network profile** to **All-Traffic**.
2. Select **Save**.

Scenario 3: Centralized traffic on a controller with per-user traffic routing

This scenario illustrates how to centralize the traffic from a VSC that is deployed on several APs on different subnets and send it to different VLANs for different groups of users. (On an MSM720, replace **LAN port** with **Access network** and **Internet port** with **Internet network** in the following descriptions.)

How it works

In this scenario, a single controller manages several APs deployed on different subnets. The default VSC (named HP) is assigned to each AP and is used to provide wireless services for users. All traffic on this VSC is tunneled to the controller by MTM, where it is egressed onto different VLANs for different user groups.

An account profile is created for each user that define the egress VLAN for their traffic. This profile is then associated with the users account.

WPA is enabled on the VSC to control user authentication. When the user logs in, the VLAN is retrieved from the account profile and is used by MTM to route the users traffic to the appropriate network via the Internet port.

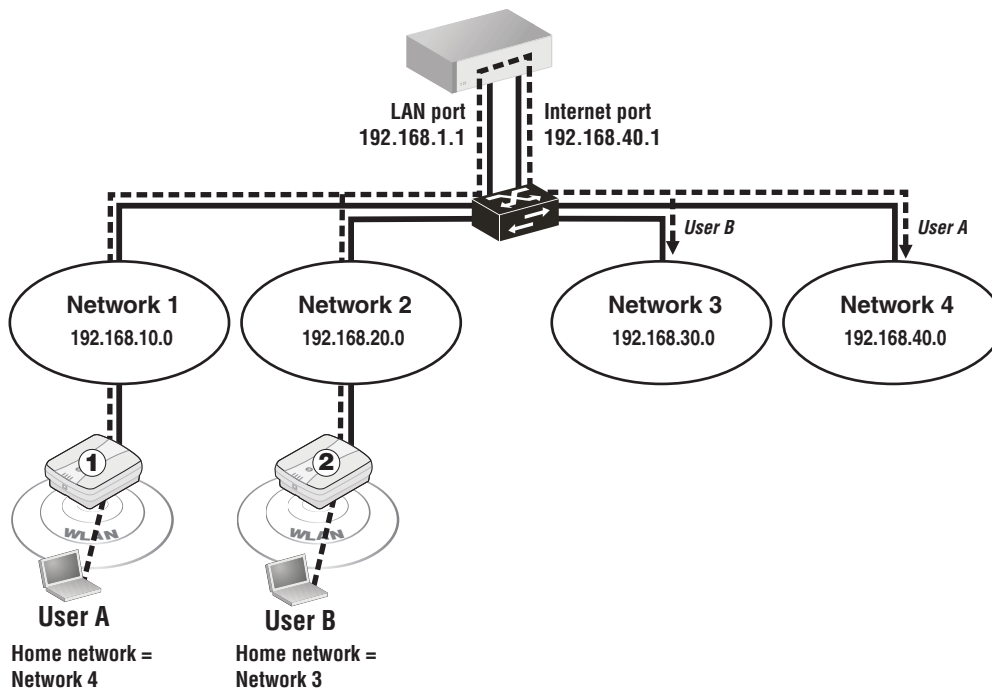

Configuration overview

The following sections provide a summary of the configuration settings needed to enable MTM support only. It is assumed that installation and configuration of all controllers and APs so that they are fully operational on the network was performed as explained in the other chapters in this guide.

VSC configuration

Enable MTM support on the VSC.

1. Select **Controller >> VSCs > HP**.
 - Under **Global**, clear **Access control**.

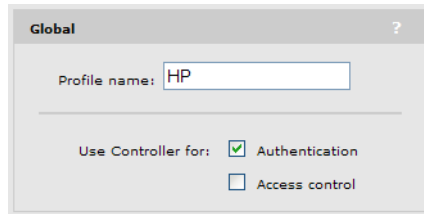

(For a complete screenshot of this page, see “VSC configuration options” (page 113).)

- Select **Wireless mobility**, then under it:
- Select **Mobility traffic manager**.
- Select **Block user**.

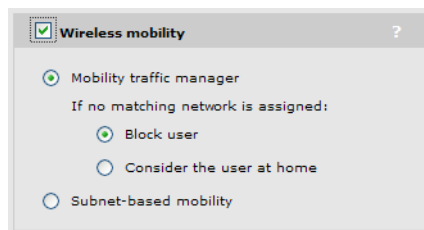

- Select **Wireless protection**, and then select **WPA**. Under it, do the following:
- Set **Mode** to **WPA (TKIP)**.
- Set **Key source** to **Dynamic**.

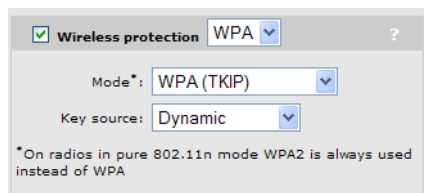

This will automatically enable the **802.1X authentication** option and set it to use the local user accounts.

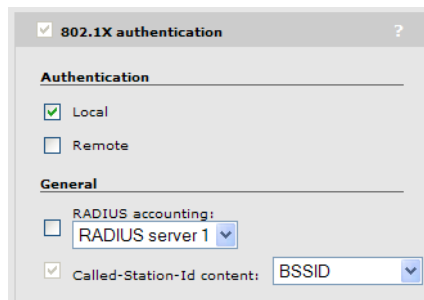

2. Select **Save**.

Network profiles

Define network profiles that with VLAN IDs of 30 and 40.

1. Select **Controller >> Network > Network profiles**.

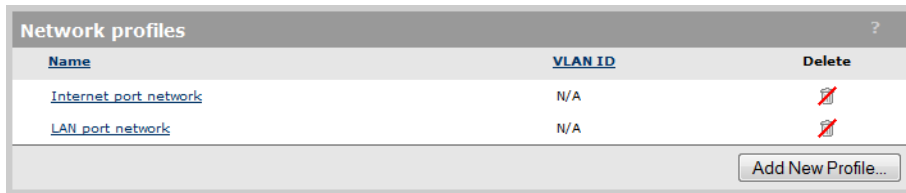

2. Select **Add New Profile**.
3. Under **Settings**, set **Name** to **Network 3**.
4. Select **VLAN ID**, and specify a value of **30**.

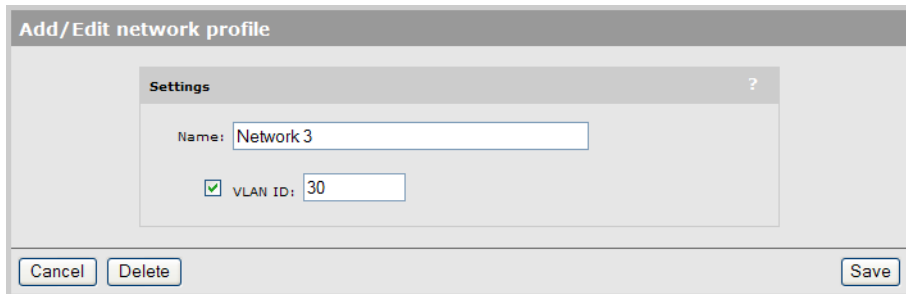

5. Select **Save**.
6. Select **Add New Profile**.
7. Under **Settings**, set **Name** to **Network 4**.
8. Select **VLAN ID**, and specify a value of **40**.

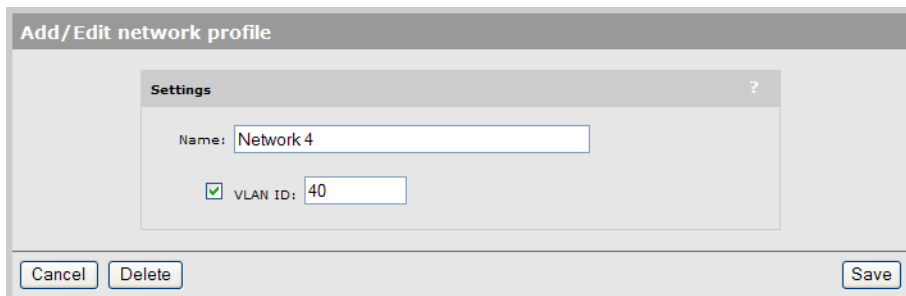

9. Select **Save**.

Map the profiles to a port

Map the network profiles to port 1 on the MSM720 or the Internet port on other controllers.

1. Select **Controller >> Network > VLANs**.

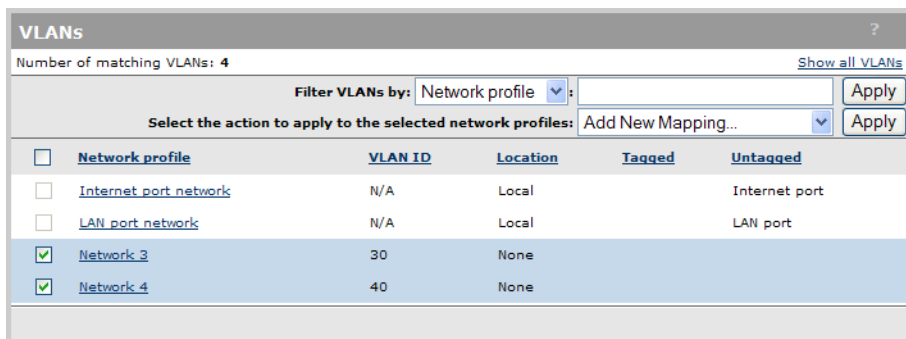

2. Select **Network 3** and **Network 4** in the list.
3. For **Select the action to apply to the selected network profiles**, select **Add New Mapping**, then select **Apply**. The Add/Edit VLAN mapping page opens.

Network profile	VLAN ID
Network 4	40
Network 3	30

Port: Internet port

4. Under **Map To**, select **Internet port**.
5. Select **Save**. The VLANs page opens showing the profiles mapped to the Internet port.

Network profile	VLAN ID	Location	Tagged	Untagged
Internet port network	N/A	Local		Internet port
LAN port network	N/A	Local		LAN port
Network 3	30	Local	Internet port	
Network 4	40	Local	Internet port	

User accounts

Next you need to define user accounts and account profiles.

1. Select **Controller >> Users > Account profiles**.

Name	Type
Default AC	Access Controlled

Add New Profile...

2. Select **Add New Profile**.
3. Under **General**, set **Profile name** to **Network 3** and disable **Access-controlled profile**.
4. Select **Egress interface**, and under it select **Egress VLAN ID** and set it to **30**.

Add/Edit account profile

General ?

Profile name:

Access-controlled profile

Session time attributes ?

Reauthentication period: seconds

Termination action:

Idle timeout: seconds

Accounting interim interval: seconds

Egress interface ?

Egress VLAN ID:

Custom attributes ?

Name	Type	Value	Move	Delete
No custom attributes are defined.				

[Add New Attribute...](#)

Cancel
Delete
Save

5. Select **Save**.
6. Select **Add New Profile**.
7. Under **General**, set **Profile name** to **Network 4** and disable **Access-controlled profile**.
8. Select **Egress interface**, and under it select **Egress VLAN ID** and set it to **40**.

Add/Edit account profile

General ?

Profile name:

Access-controlled profile

Session time attributes ?

Reauthentication period: seconds

Termination action:

Idle timeout: seconds

Accounting interim interval: seconds

Egress interface ?

Egress VLAN ID:

Custom attributes ?

Name	Type	Value	Move	Delete
No custom attributes are defined.				

[Add New Attribute...](#)

Cancel
Delete
Save

9. Select **Save**. The profiles list should now look like this:

Account profiles ?

Name	Type
Default AC	Access Controlled
Network 3	Not Access Controlled
Network 4	Not Access Controlled

[Add New Profile...](#)

10. Select **Controller >> Users > User accounts**. Initially, no accounts are defined.

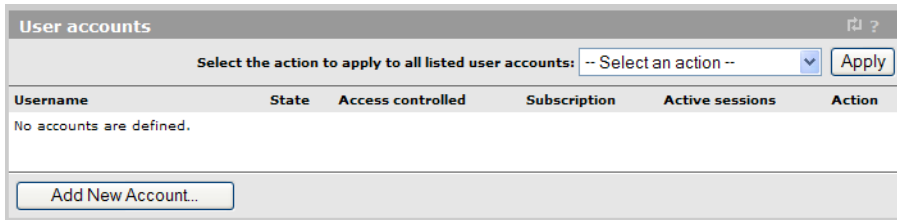

11. Select **Add New Account**.

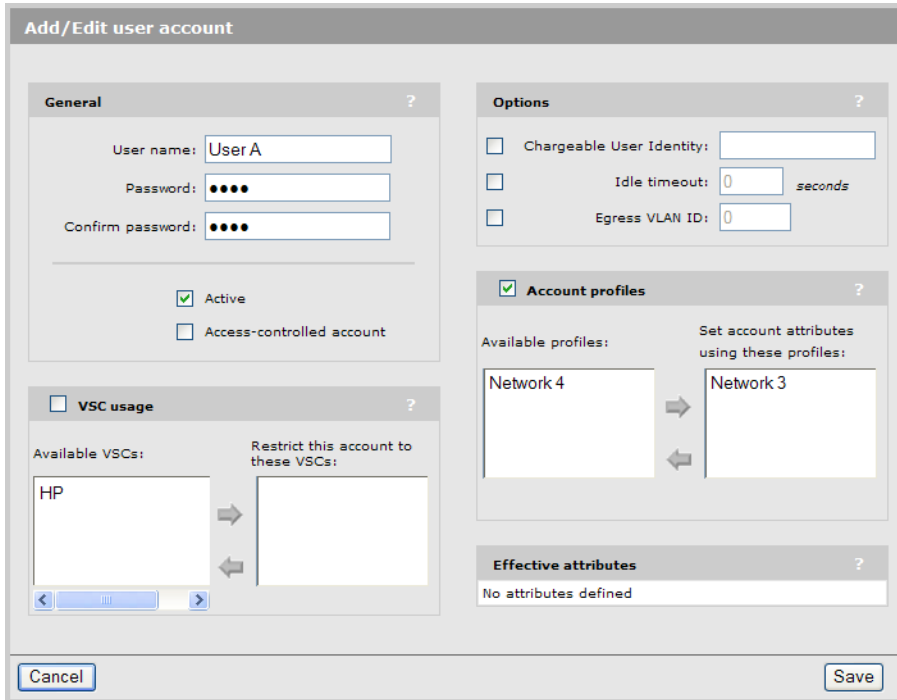

12. Under **General**:

- Set **User name** to **User A**.
- Set **Password** to a secure password.
- Clear **Access-controlled account**.

13. Select **Account profiles**, and under it move **Network 3** to the box titled **Set account attributes using these profiles**.

14. Select **Save**.

15. Select **Add New Account**.

16. Under **General**:
 - Set **User name** to **User B**.
 - Set **Password** to a secure password.
 - Clear **Access-controlled account**.
17. Select **Account profiles**, and under it move **Network 4** to the box titled **Set account attributes using these profiles**.
18. Select **Save**.

VSC binding

This scenario assumes that all APs are part of the **Default Group**.

1. Select **Controlled APs > Default Group >> VSC bindings** and then select **HP**. The VSC binding page appears.

- Under **VSC Profile**, set **VSC profile** to **HP**.
2. Select **Save**.

Scenario 4: Assigning home networks on a per-user basis

This scenario illustrates how to assign home networks on a per-user basis using RADIUS attributes. (On an MSM720, replace **LAN port** with **Access network** in the following descriptions.)

How it works

In this scenario, wireless services have been added to two wired networks. A single controller and multiple APs are installed on each network. The two networks are connected with an L3 switch. The following diagram provides an overview of the setup. (A single AP is shown on each network for clarity).

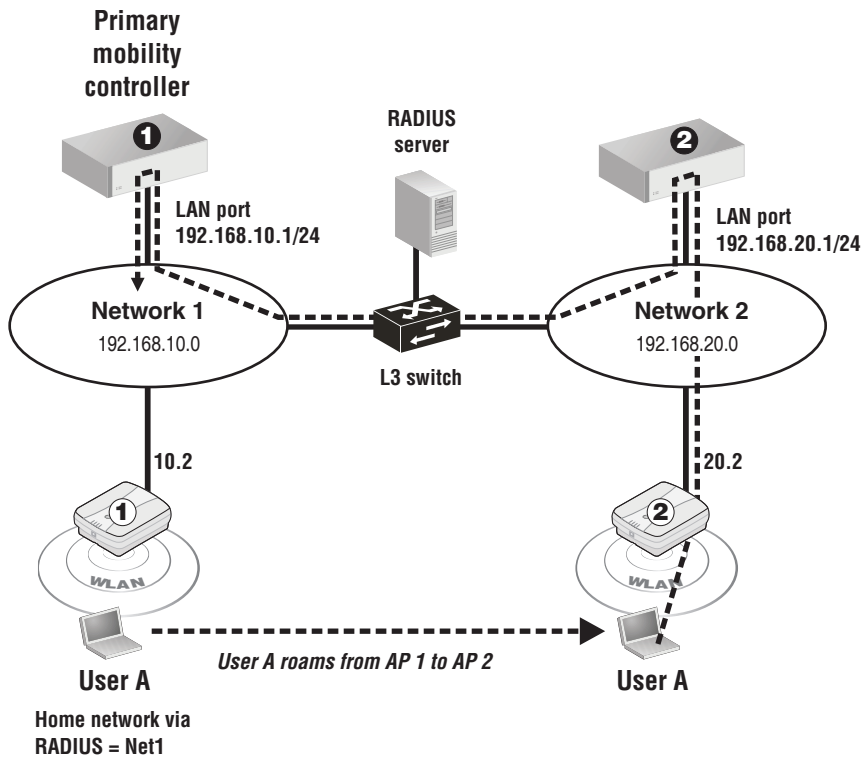

Wireless clients receive their DHCP address from the controller on their network, or use a static IP addressing scheme.

A single VSC is used in this scenario. It is configured with the **Mobility traffic manager** option enabled. Home network assignment for users is done by setting RADIUS VLAN attributes which map users to one of two network profiles:

Network profile name	Assigned to
Net1	<ul style="list-style-type: none"> Controller 1 LAN port All APs attached to network 10.0 use this as their home network
Net2	<ul style="list-style-type: none"> Controller 2 LAN port All APs attached to network 20.0 use this as their home network

Each profile must be assigned to an AP as well as a controller. This is done to ensure that when a user logs in on an AP installed on the same subnet as the home network, traffic is not routed through the controller, but is sent directly onto the network via the Ethernet port on the AP. For example:

- When User A logs onto AP 1, RADIUS returns the VLAN ID **Net1**. Since **Net1** is defined as a home network on AP 1, traffic is sent directly onto network 1 via the Ethernet port on the AP.
- When User A roams to (or logs into) AP 2, RADIUS returns the VLAN ID **Net1**. Since **Net1** is not defined as a home network on AP 2, MTM tunnels the users traffic back to network 1.

A RADIUS account is defined for each user with attributes set as follows to identify the home network using a network profile name:

RADIUS attribute	Network 1 users	Network 2 users
Tunnel-Medium-Type	802	802
Tunnel-Private-Group-ID	Net1	Net2
Tunnel-Type	VLAN	VLAN

Configuration overview

The following sections provide a summary of the configuration settings needed to enable MTM support only. It is assumed that installation and configuration of all controllers and APs so that they are fully operational on the network was performed as explained in the other chapters in this guide.

Controller 1 configuration

Mobility domain

1. Select **Controller >> Management > Device discovery**.
 - Select **Mobility controller discovery**.
 - Select **This is the primary mobility controller**.

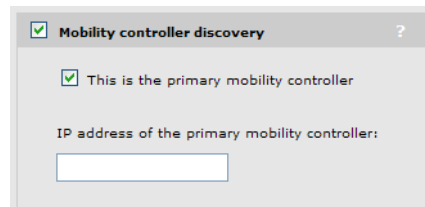

The screenshot shows a configuration window titled "Mobility controller discovery" with a question mark icon. It contains two checked checkboxes: "Mobility controller discovery" and "This is the primary mobility controller". Below these is a text label "IP address of the primary mobility controller:" followed by an empty text input field.

(For a complete screenshot of this page, see [“Defining the mobility domain” \(page 291\)](#).)

2. Select **Save**.

VSC

1. Select **Controller >> VSCs > HP**.
 - Under **Global**
 - Clear **Access control**.

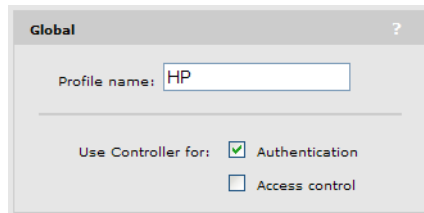

Global

Profile name: HP

Use Controller for: Authentication
 Access control

(For a complete screenshot of this page, see “VSC configuration options” (page 113).)

- Select **Wireless mobility**, then under it:
- Select **Mobility traffic manager**.
- Select **Block user**.

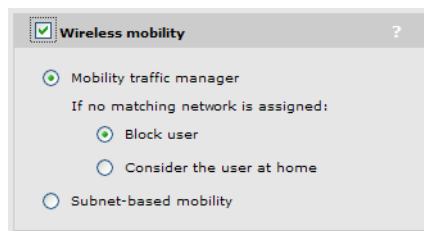

Wireless mobility

Mobility traffic manager

If no matching network is assigned:

Block user
 Consider the user at home
 Subnet-based mobility

(For a complete screenshot of this page, see “VSC configuration options” (page 113).)

2. Select **Save**.

Network profiles

1. Select **Controller >> Network > Network profiles**.



Name	VLAN ID	Delete
Internet port network	N/A	
LAN port network	N/A	

Add New Profile...

2. Select **LAN port network**.
3. Under **Settings**, change **Name** to **Net1**.

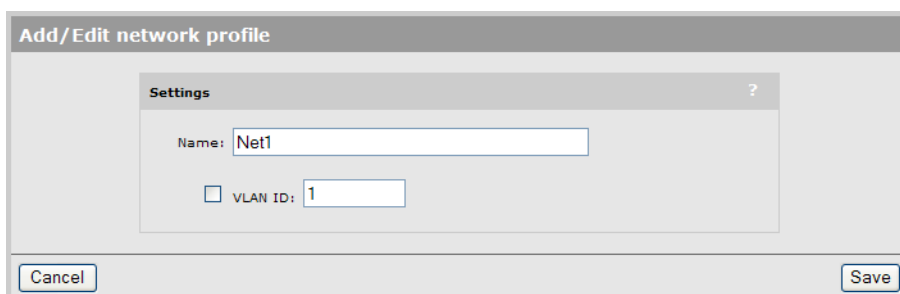

Add/Edit network profile

Settings

Name: Net1

VLAN ID: 1

Cancel Save

4. Select **Save**.

Controller 2 configuration

Mobility domain

1. Select **Controller >> Management > Device discovery**.

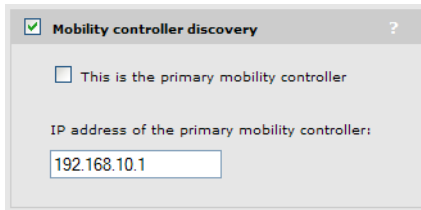

The screenshot shows a dialog box titled "Mobility controller discovery" with a checkmark in the top-left corner. It contains a checkbox labeled "This is the primary mobility controller" which is unchecked. Below this is a text field labeled "IP address of the primary mobility controller:" containing the value "192.168.10.1".

(For a complete screenshot of this page, see “Defining the mobility domain” (page 291).)

- Select **Mobility controller discovery**.
 - Clear **This is the primary mobility controller**.
 - Specify the **IP address of the primary mobility controller**. In this example: **192.168.10.1**.
2. Select **Save**.



VSC

VSC configuration is the same as for controller 1.

Network profiles

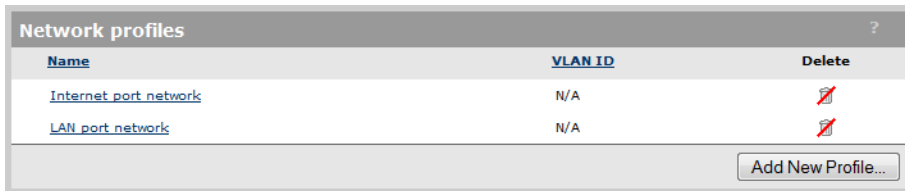
1. Select **Controller >> Network > Network profiles**.



Name	VLAN ID	Delete
Internet port network	N/A	
LAN port network	N/A	

[Add New Profile...](#)

2. Select **LAN port network**.
3. Under **Settings**, change **Name** to **Net2**.

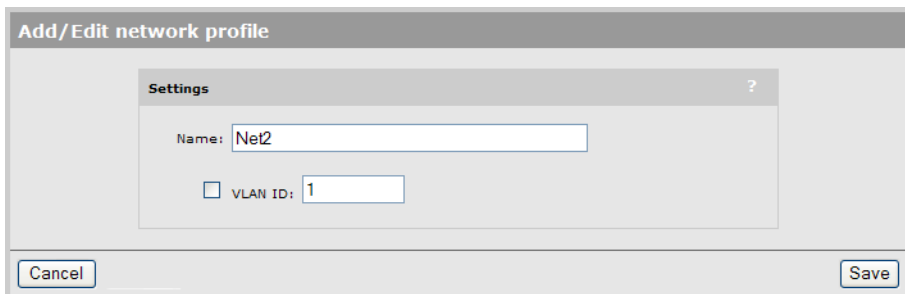

The screenshot shows a dialog box titled "Add/Edit network profile" with a "Settings" sub-dialog. The "Settings" dialog has a text field for "Name:" containing "Net2" and a checkbox for "VLAN ID:" which is unchecked, with a text field next to it containing "1". At the bottom of the "Settings" dialog are "Cancel" and "Save" buttons.

4. Select **Save**.

AP configuration

VSC binding

1. Select **Controller > Controlled APs > Default Group >> VSC bindings** and then select **HP**. The **VSC binding** page appears.

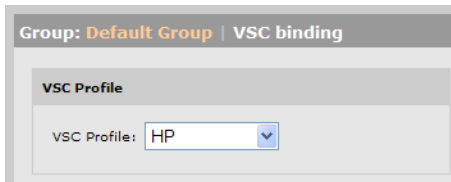

(For complete screenshot see “VSC configuration options” (page 113).)

- Set **VSC profile** to **HP**.
2. Select **Save**.

Local network assignment

1. Select **Controlled APs > Default group >> Configuration > Home networks**.
 - For each AP on network 1, double-click **Net1** to add it to the **Local networks** list.
 - For each AP on network 2, double-click **Net2** to add it to the **Local networks** list.

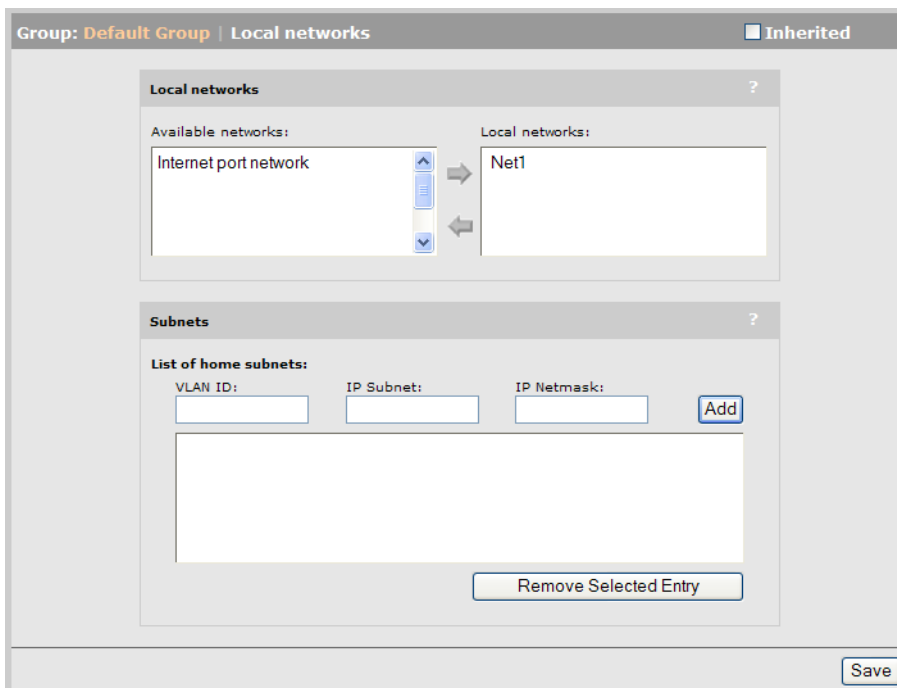

2. Select **Save**.

Scenario 5: Traffic routing using VLANs

This scenario explains how to route the traffic from users onto specific VLANs on the wired network.

How it works

In this scenario, traffic on a corporate network is routed using VLANs, creating several logical networks to isolate the network resources for each workgroup. A number of wireless APs are distributed throughout the company and are connected using VLAN 2. Network administrators use VLAN 1 for all equipment installed on the network and in the network operations center (NOC).

The following diagram provides a logical overview of the setup. (Only two APs are shown for clarity).

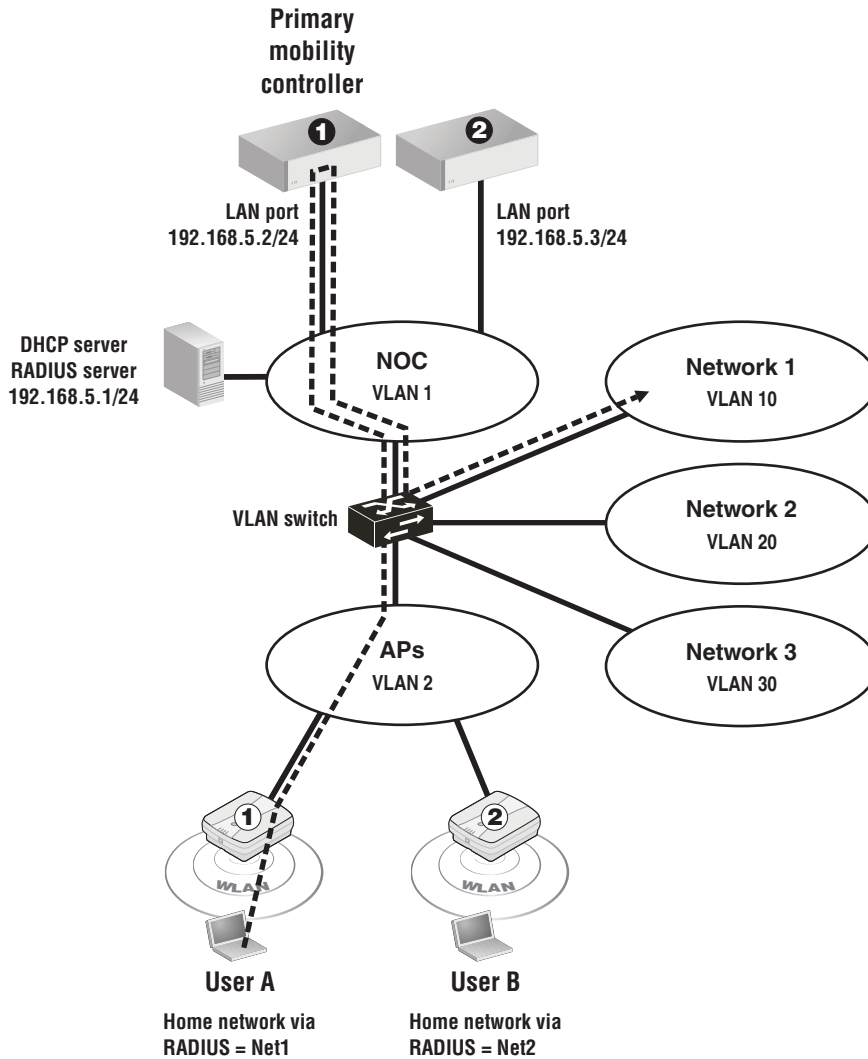

Wireless clients receive their DHCP address from the DHCP server on the network.

A single VSC is used. It is configured with the **Mobility traffic manager** option enabled. Home networks for users are determined by setting RADIUS VLAN attributes, which map users to the following network profiles:

Network profile name	Assigned to LAN port on	Assigned to VLAN ID
Net1	Controller 1	10
Net2	Controller 2	20
Net3	Controller 2	30
NOC	Controller 1	1

Since all traffic is routed to the VLANs through the LAN port on either controller 1 or 2, no home networks are assigned on the APs.

By assigning different VLANs to different controller ports, traffic can be split between controllers. To reduce the amount of traffic that needs to be tunneled between controllers, APs are assigned to controllers based on their expected use:

- AP 1 is physically located in an area where most of the users are assigned to network 1, therefore it is managed by controller 1.
- AP 2 is physically located in an area where most of the users are assigned to network 2, therefore it is managed by controller 2.

A RADIUS account is defined for each user with attributes set to identify their home network using one of the network profile names:

RADIUS attribute	Network 1 users	Network 2 users	Network 3 users	Network administrators
Tunnel-Medium-Type	802	802	802	802
Tunnel-Private-Group-ID	Net1	Net2	Net3	NOC
Tunnel-Type	VLAN	VLAN	VLAN	VLAN

Configuration overview

The following sections provide a summary of the configuration settings needed to enable MTM support only. It is assumed that installation and configuration of all controllers and APs so that they are fully operational on the network was performed as explained in the other chapters in this guide.

Controller 1 configuration

Mobility domain

1. Select **Controller >> Management > Device discovery**.
 - Select **Mobility controller discovery**.
 - Select **This is the primary mobility controller**.

(For a complete screenshot of this page, see [“Defining the mobility domain”](#) (page 291).)

2. Select **Save**.

VSC

1. Select **Controller >> VSCs > HP**.
 - Under **Global**, disable **Access control**.

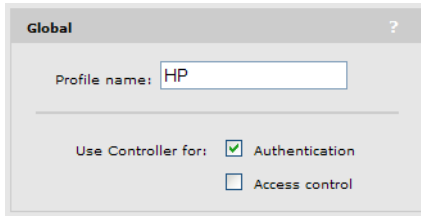

The screenshot shows a window titled "Global" with a profile name field set to "HP". Below this, there are two checkboxes: "Use Controller for: Authentication" (checked) and "Access control" (unchecked).

(For complete screenshot see ["VSC configuration options"](#) (page 113).)

- Select **Wireless mobility**, then under it:
- Select **Mobility traffic manager**.
- Select **Block user**.

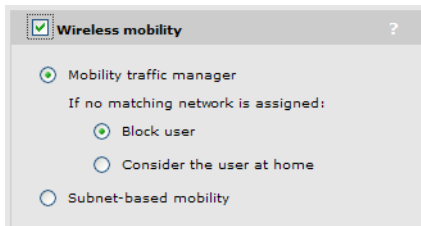

The screenshot shows a window titled "Wireless mobility" with a checked checkbox. Underneath, there are three radio button options: "Mobility traffic manager" (selected), "Consider the user at home", and "Subnet-based mobility". Under "Mobility traffic manager", there are two sub-options: "Block user" (selected) and "Consider the user at home".

(For a complete screenshot of this page, see ["VSC configuration options"](#) (page 113).)

2. Select **Save**.

Network profiles

1. Select **Controller >> Network > Network profiles**.

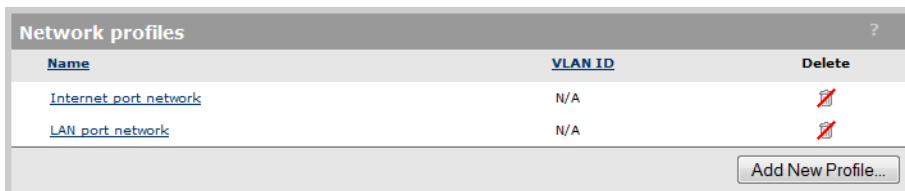

Name	VLAN ID	Delete
Internet port network	N/A	
LAN port network	N/A	

Buttons: Add New Profile...

2. Select **Add New Profile**.

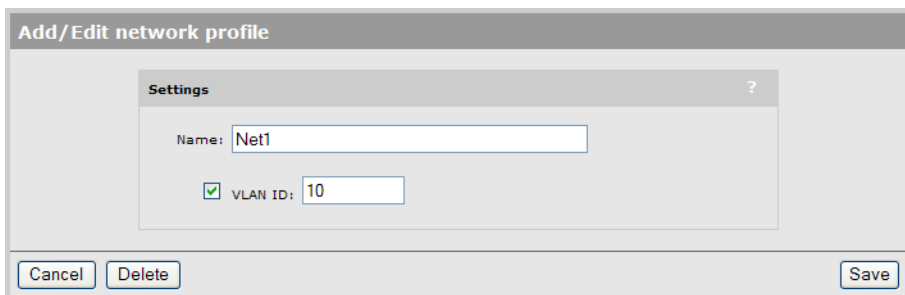

The screenshot shows a dialog titled "Add/Edit network profile" with a "Settings" sub-dialog. The "Name" field is set to "Net1" and the "VLAN ID" checkbox is checked with a value of "10". Buttons for "Cancel", "Delete", and "Save" are visible at the bottom.

- Under **Settings**, set **Name** to **Net1**.
 - Select **VLAN ID** and set a value of **10**.
3. Select **Save**.

4. Repeat steps 2 and 3 to define the following profiles:
 - Profile name = **NOC**, VLAN ID = **1**
 - Profile name = **APs**, VLAN ID = **2**
5. When done, the list of network profiles should look like this:

Network profiles		
Name	VLAN ID	Delete
APs	2	
Internet port network	N/A	
LAN port network	N/A	
Net1	10	
NOC	1	

[Add New Profile...](#)

VLANS

1. Select **Controller >> Network > VLANs**.

VLANs					
Number of matching VLANs: 5					Show all VLANs
Filter VLANs by: Network profile					<input type="text"/> <input type="button" value="Apply"/>
Select the action to apply to the selected network profiles:					<input type="button" value="Add New Mapping..."/> <input type="button" value="Apply"/>
<input type="checkbox"/>	Network profile	VLAN ID	Location	Tagged	Untagged
<input checked="" type="checkbox"/>	APs	2	None		
<input type="checkbox"/>	Internet port network	N/A	Local		Internet port
<input type="checkbox"/>	LAN port network	N/A	Local		LAN port
<input checked="" type="checkbox"/>	Net1	10	None		
<input checked="" type="checkbox"/>	NOC	1	None		

2. Select **APs**, **Net1**, and **NOC**. For **Select the action to apply to the selected network profiles**, select **Add New Mapping**, then select **Apply**. The Add/Edit VLAN mapping page opens

Add/Edit VLAN mapping									
Selected network profiles		Map to							
<table border="1"> <thead> <tr> <th>Network profile</th> <th>VLAN ID</th> </tr> </thead> <tbody> <tr> <td>NOC</td> <td>1</td> </tr> <tr> <td>Net1</td> <td>10</td> </tr> <tr> <td>APs</td> <td>2</td> </tr> </tbody> </table>	Network profile	VLAN ID	NOC	1	Net1	10	APs	2	Port <input type="text" value="LAN port"/>
Network profile	VLAN ID								
NOC	1								
Net1	10								
APs	2								
<input type="button" value="Cancel"/> <input type="button" value="Delete"/>	<input type="button" value="Save"/>								

3. Under **Map to**, set **Port** to **LAN port**.

4. Select **Save**. The list of VLANs should look like this:

<input type="checkbox"/> <u>Network profile</u>	<u>VLAN ID</u>	<u>Location</u>	<u>Tagged</u>	<u>Untagged</u>
<input type="checkbox"/> APs	2	Local	LAN port	
<input type="checkbox"/> Internet port network	N/A	Local		Internet port
<input type="checkbox"/> LAN port network	N/A	Local		LAN port
<input type="checkbox"/> Net1	10	Local	LAN port	
<input type="checkbox"/> NOC	1	Local	LAN port	

Controller 2 configuration

Mobility domain

1. Select **Controller >> Management > Device discovery**.

Mobility controller discovery

This is the primary mobility controller

IP address of the primary mobility controller:

(For complete screenshot see “Defining the mobility domain” (page 291).)

- Select **Mobility controller discovery**.
 - Clear **This is the primary mobility controller**.
 - Set the **IP address of the primary mobility controller** to **192.168.5.2**.
2. Select **Save**.

VSC

Configuration is the same as for controller 1.

Network profiles

1. Select **Controller >> Network > Network profiles**.

<u>Name</u>	<u>VLAN ID</u>	<u>Delete</u>
Internet port network	N/A	
LAN port network	N/A	

2. Select **Add New Profile**.

Add/Edit network profile

Settings ?

Name:

VLAN ID:

- Under **Settings**, set **Name** to **Net2**.
 - Select **VLAN ID** and set a value of **20**.
3. Select **Save**.
 4. Repeat steps 2 and 3 to define the following profiles:
 - Profile name = **Net3**, VLAN ID = **30**
 - Profile name = **APs**, VLAN ID = **2**
 5. When done, the list of network profiles should look like this:

VLANs ?

Number of matching VLANs: 5 [Show all VLANs](#)

Filter VLANs by: Network profile

Select the action to apply to the selected network profiles: Add New Mapping...

<input type="checkbox"/>	Network profile	VLAN ID	Location	Tagged	Untagged
<input checked="" type="checkbox"/>	AP	2	None		
<input type="checkbox"/>	Internet port network	N/A	Local		Internet port
<input type="checkbox"/>	LAN port network	N/A	Local		LAN port
<input checked="" type="checkbox"/>	Net2	20	None		
<input checked="" type="checkbox"/>	Net3	30	None		

VLANs

1. Select **Controller >> Network > VLANs**.

VLANs ?

Number of matching VLANs: 5 [Show all VLANs](#)

Filter VLANs by: Network profile

Select the action to apply to the selected network profiles: Add New Mapping...

<input type="checkbox"/>	Network profile	VLAN ID	Location	Tagged	Untagged
<input checked="" type="checkbox"/>	AP	2	None		
<input type="checkbox"/>	Internet port network	N/A	Local		Internet port
<input type="checkbox"/>	LAN port network	N/A	Local		LAN port
<input checked="" type="checkbox"/>	Net2	20	None		
<input checked="" type="checkbox"/>	Net3	30	None		

2. Select **APs, Net1, and NOC**. For **Select the action to apply to the selected network profiles**, select **Add New Mapping**, then select **Apply**. The Add/Edit VLAN mapping page opens

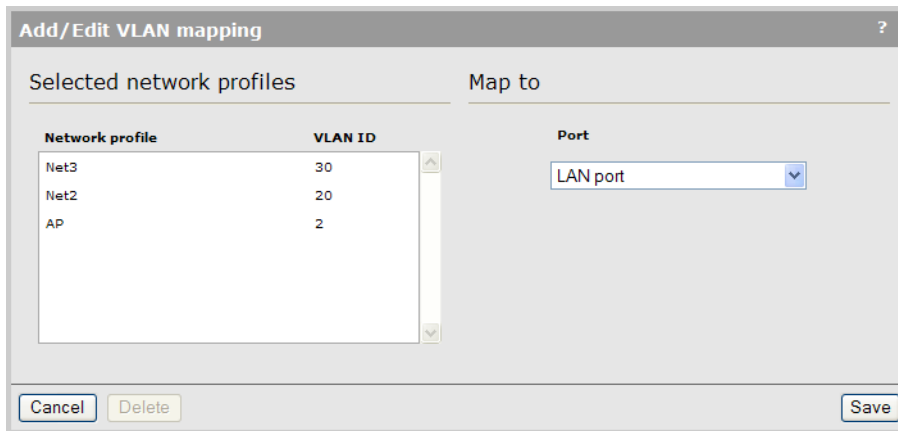

- Under **Map to**, set **Port** to **LAN port**.
- Select **Save**. The list of VLANs should look like this:

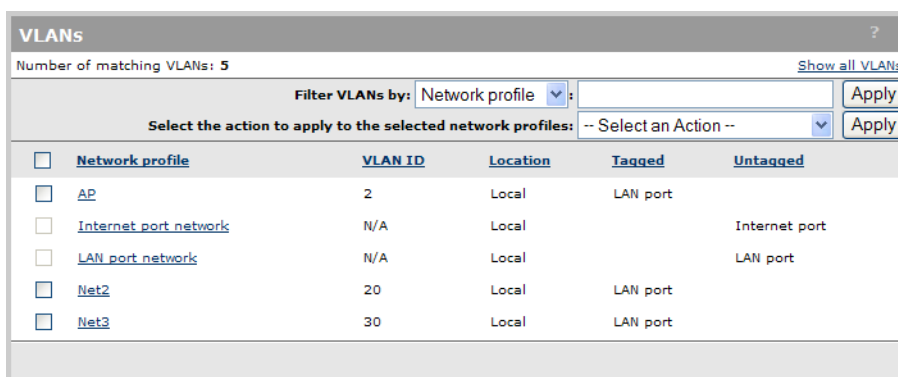

AP configuration

VSC binding

- Select **Controller > Controlled APs > Default Group >> VSC bindings** and then select **HP**. The **VSC binding** page appears.

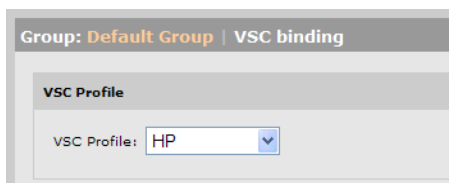

(For complete screenshot see [“Binding a VSC to a group”](#) (page 165).)

- Set **VSC profile** to **HP**.
- Select **Save**.

Scenario 6: Distributing traffic using VLAN ranges

This scenario explains how to automatically distribute wireless network traffic onto multiple VLANs on the wired network.

How it works

In this scenario, traffic on a corporate network is segmented onto multiple VLANs to address performance and scalability issues. Traffic from the users on wireless APs needs to be deployed

in the same manner. Rather than manually assigning APs and/or groups of users to specific VLANs, MTM can be configured to automatically disperse traffic across a VLAN range. In fact, by defining multiple network profiles, traffic can be mapped to several different ranges, allowing groups of users or APs to be mapped to specific VLAN ranges.

The following diagram provides a logical overview of the setup. (Only two APs are shown for clarity).

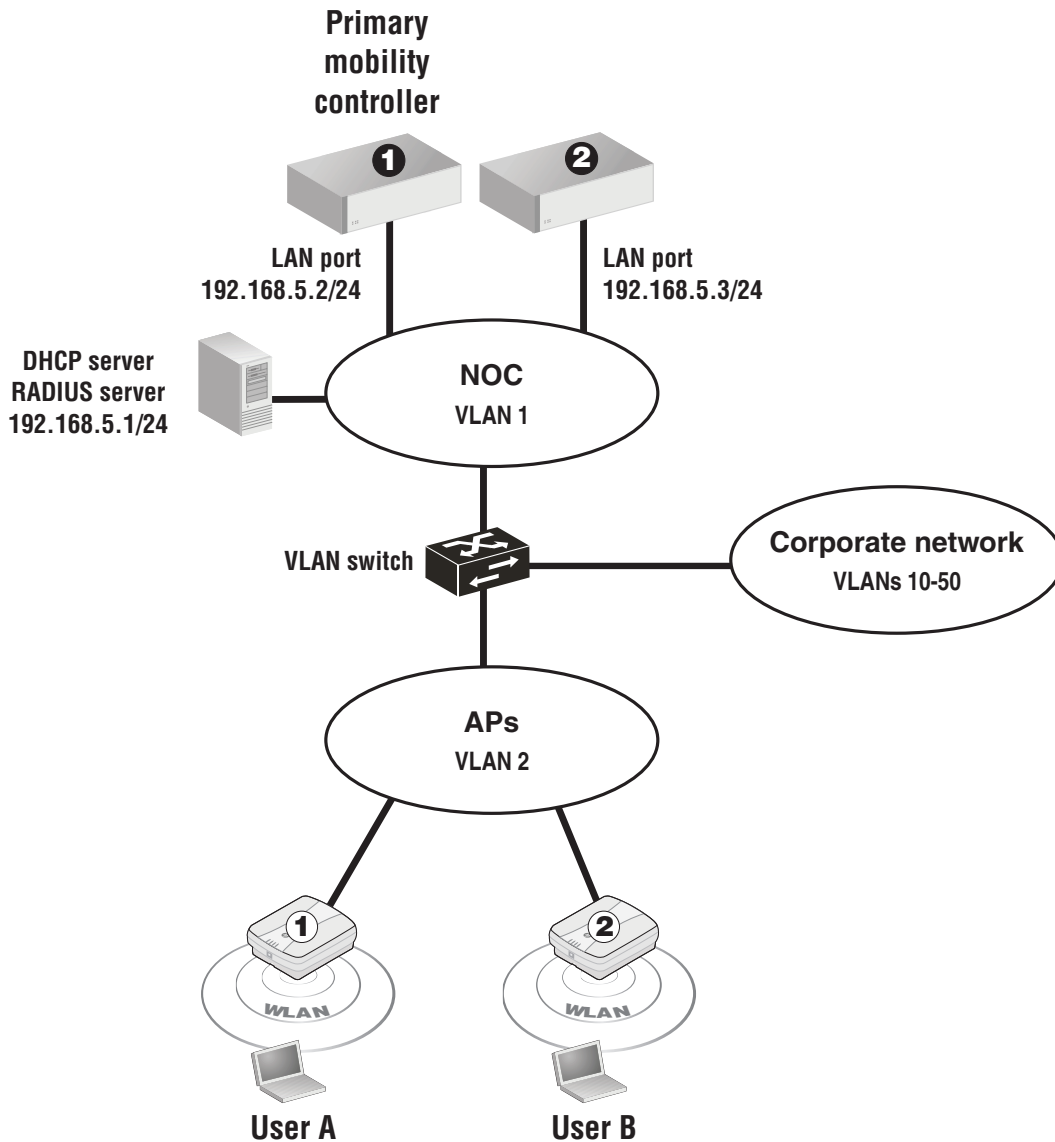

Wireless clients receive their DHCP address from the DHCP server on the network.

A single VSC is used. It is configured with the **Wireless mobility, Mobility traffic manager** option enabled. The home network for users is defined by setting the Egress network when the VSC is bound to the APs. The Egress network is mapped to a network profile that defines a range of VLANs on the LAN port on the controller.

Network profile name	Assigned to LAN port on	Assigned to VLAN range
Net1	Controller 1	10-30
Net2	Controller 2	31-50

By assigning a different profile name to AP groups, traffic can be split between controllers. In this example, the APs are split into two groups:

- **Group 1:** The VSC binding is configured with Egress network set to **Net1**, putting traffic from this group onto VLAN range 10-30.
- **Group 2:** The VSC binding is configured with Egress network set to **Net2**, putting traffic from this group onto VLAN range 31-50.

MTM uses a round-robin mechanism to distribute traffic across the VLANs range. The first wireless user is assigned to the first VLAN in the range. Subsequent users are assigned to the next VLAN in the range. When the range is exhausted, assignment starts with the first VLAN again. For example, if the VLAN range is defined as VLAN IDs 1 to 20, the first user is assigned to VLAN 1. The second is assigned to VLAN 2. The 21st user is assigned to VLAN 1 again. Although VLAN assignment is sequential through the range, from the users point of view, VLAN assignment will appear to be random.

Configuration overview

The following sections provide a summary of the configuration settings needed to enable MTM support only. It is assumed that installation and configuration of all controllers and APs so that they are fully operational on the network was performed as explained in the other chapters in this guide.

Controller 1 configuration

Mobility domain

1. Select **Controller >> Management > Device discovery**.
 - Select **Mobility controller discovery**.
 - Select **This is the primary mobility controller**.

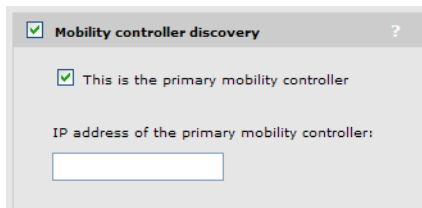

The screenshot shows a configuration dialog box titled "Mobility controller discovery" with a question mark icon in the top right corner. Inside the dialog, there are two checked checkboxes: "Mobility controller discovery" and "This is the primary mobility controller". Below these checkboxes, there is a label "IP address of the primary mobility controller:" followed by an empty text input field.

(For a complete screenshot of this page, see [“Defining the mobility domain”](#) (page 291).)

2. Select **Save**.

VSC

1. Select **Controller >> VSCs > HP**.

Under Global

- Clear **Access control**.

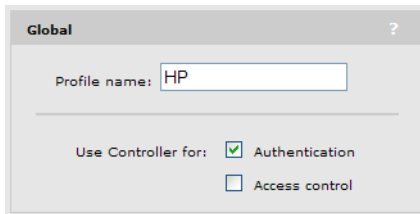

The screenshot shows the 'Global' configuration window for the 'HP' profile. The 'Profile name' field contains 'HP'. Under the 'Use Controller for:' section, the 'Authentication' checkbox is checked, and the 'Access control' checkbox is unchecked.

(For a complete screenshot of this page, see “VSC configuration options” (page 113).)

- Select **Wireless mobility**, then under it:
- Select **Mobility traffic manager**.
- Select **Block user**.

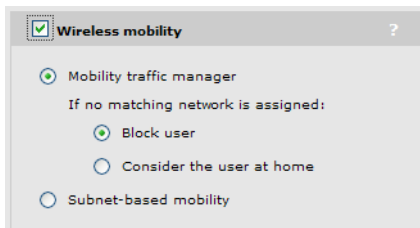

The screenshot shows the 'Wireless mobility' configuration window. The 'Wireless mobility' checkbox is checked. Under 'Mobility traffic manager', the 'Block user' radio button is selected. Other options include 'Consider the user at home' and 'Subnet-based mobility'.

(For a complete screenshot of this page, see “VSC configuration options” (page 113).)

2. Select **Save**.

Network profiles

1. Select **Controller >> Network > Network profiles**.



Name	VLAN ID	Delete
Internet port network	N/A	
LAN port network	N/A	

Buttons: Add New Profile...

2. Select **Add New Profile**.

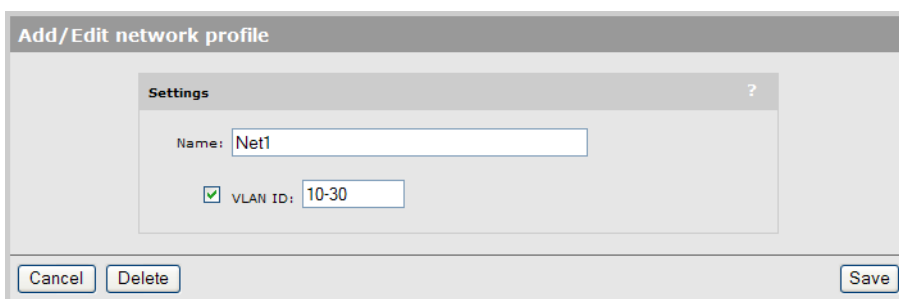

The screenshot shows the 'Add/Edit network profile' dialog box. Under the 'Settings' section, the 'Name' field is set to 'Net1'. The 'VLAN ID' checkbox is checked, and the value '10-30' is entered in the adjacent field. Buttons for 'Cancel', 'Delete', and 'Save' are visible at the bottom.

- Under **Settings**, set **Name** to **Net1**.
- Select **VLAN ID** and set a value of **10-30**.

3. Select **Save**.

VLANs

1. Select **Controller >> Network > VLANs**.

<input type="checkbox"/>	Network profile	VLAN ID	Location	Tagged	Untagged
<input type="checkbox"/>	Internet port network	N/A	Local		Internet port
<input type="checkbox"/>	LAN port network	N/A	Local		LAN port
<input type="checkbox"/>	Net1	10-30	None		

2. Select **Net1**. The Add/Edit VLAN mapping page opens.

Network profile	VLAN ID
Net1	10-30

Port: LAN port

- Under **Map to**, set **Port** to **LAN port**.

3. Select **Save**.

Controller 2 configuration

Mobility domain

1. Select **Controller >> Management > Device discovery**.

Mobility controller discovery

This is the primary mobility controller

IP address of the primary mobility controller:
192.168.5.2

(For complete screenshot see “Defining the mobility domain” (page 291).)

- Select **Mobility controller discovery**.
- Clear **This is the primary mobility controller**.
- Set the **IP address of the primary mobility controller** to **192.168.5.2**.

2. Select **Save**.

VSC

Configuration is the same as for controller 1.

Network profiles

1. Select **Controller >> Network > Network profiles**.

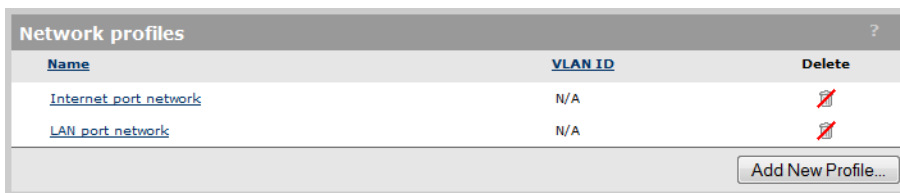

The screenshot shows a table titled "Network profiles" with three columns: Name, VLAN ID, and Delete. There are two rows of data. Below the table is an "Add New Profile..." button.

Name	VLAN ID	Delete
Internet port network	N/A	
LAN port network	N/A	

2. Select **Add New Profile**.

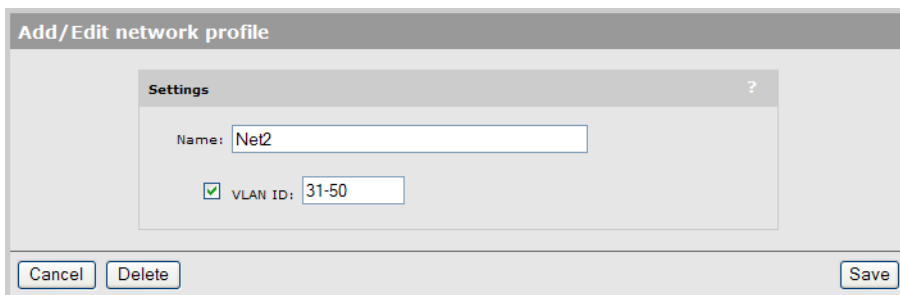

The screenshot shows the "Add/Edit network profile" dialog box. It has a "Settings" section with a "Name" field containing "Net2" and a "VLAN ID" field with a checked checkbox and the value "31-50". There are "Cancel", "Delete", and "Save" buttons at the bottom.

- Under **Settings**, set **Name** to **Net2**.
- Select **VLAN ID** and set a value of **31–50**.

3. Select **Save**.

VLANs

1. Select **Controller >> Network > VLANs**.

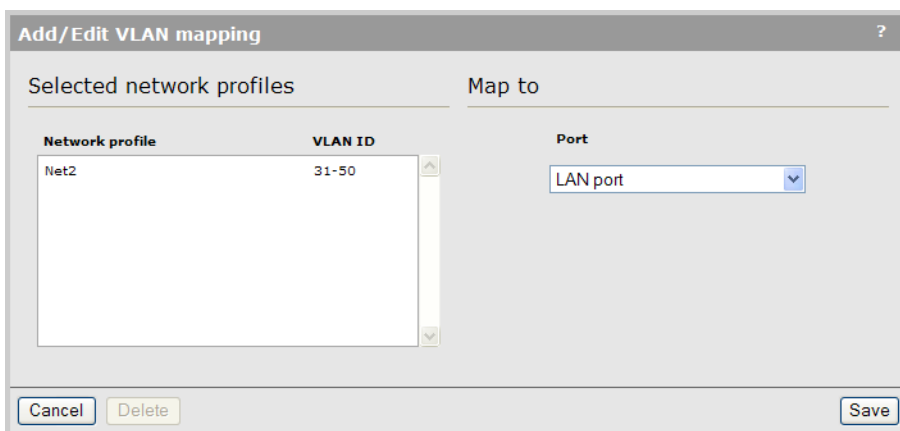

The screenshot shows the "Add/Edit VLAN mapping" dialog box. It is split into two panes: "Selected network profiles" and "Map to". The "Selected network profiles" pane shows a table with "Net2" and "31-50". The "Map to" pane has a "Port" dropdown menu set to "LAN port". There are "Cancel", "Delete", and "Save" buttons at the bottom.

2. Select **Net2**. The Add/Edit VLAN mapping page opens.

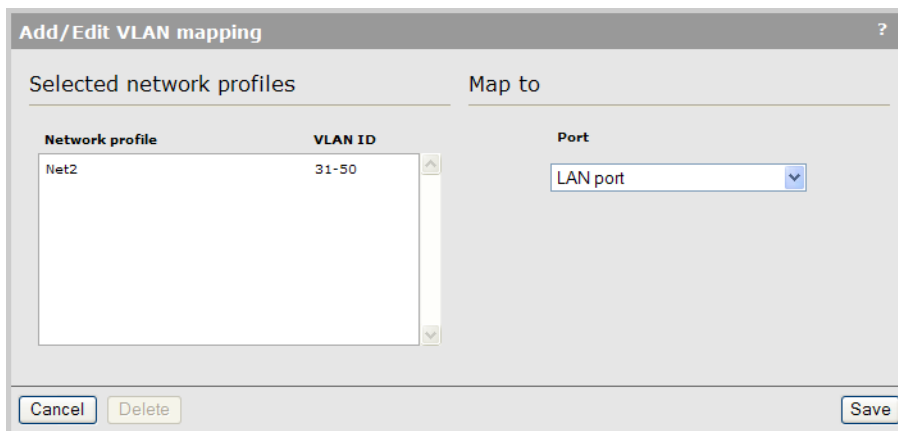

- Under **Map to**, set **Port** to **LAN port**.
3. Select **Save**.

AP configuration

Split the APs into two groups as explained in “Working with groups” (page 164). Call them **Group 1** and **Group 2**.

VSC binding for Group 1

1. Select **Controller > Controlled APs > Group 1 >> VSC bindings** and then select **HP**. The **VSC binding** page appears.

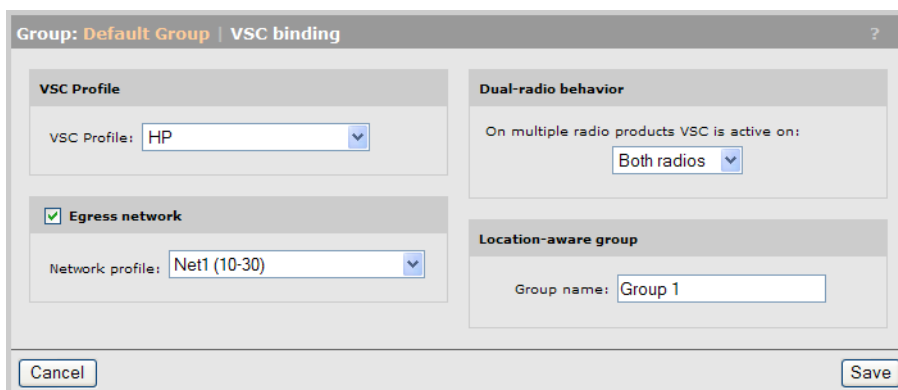

- Set **VSC profile** to **HP**.
 - Select **Egress network**, then for **Network profile**, select **Net1 (10–30)**.
2. Select **Save**.

VSC binding for Group 2

1. Select **Controller > Controlled APs > Group 2 >> VSC bindings** and then select **HP**. The **VSC binding** page appears.

The screenshot shows a configuration window titled "Group: Default Group | VSC binding". It is divided into four sections:

- VSC Profile:** A dropdown menu is set to "HP".
- Dual-radio behavior:** A dropdown menu is set to "Both radios".
- Egress network:** A checkbox labeled "Egress network" is checked. Below it, a dropdown menu is set to "Net2 (31-50)".
- Location-aware group:** A text input field is set to "Group 2".

At the bottom of the window, there are "Cancel" and "Save" buttons.

- Set **VSC profile**, to **HP**.
 - Select **Egress network**, then for **Network profile**, select **Net2 (31-50)**.
2. Select **Save**.

Subnet-based mobility

This feature has been deprecated.

If you are creating a new installation, use Mobility Traffic Manager. If you are upgrading from a previous release, your subnet-based configuration will still work. However, for added benefits and greater flexibility you should migrate your setup to Mobility Traffic Manager.

For reference, subnet-based mobility configuration options appear on the following pages:

- **Controller > Controlled APs >> Configuration > Local networks**
- **Controller > Controlled APs > [group] >> Configuration > Local networks**
- **Controller > Controlled APs > [AP] >> Configuration > Local networks**
- **Controller > VSCs >> [VSC-name]**

16 User authentication, accounts, and addressing

Introduction

NOTE: This chapter discusses user authentication as it applies to the controller and controlled APs only. For information on authentication when working with autonomous APs, see [“Working with autonomous APs” \(page 533\)](#).

User authentication tasks can be handled either by the AP or by the controller. This is controlled by the settings of the access control and authentication options on the VSC to which a user is connected. See [“About access control and authentication” \(page 114\)](#).

Authentication support

The following table lists all authentication types that are supported for user authentication and indicates how they apply to wired and wireless users.

Auth type	The Use controller for option in a VSC is set to:			For more information, see ...
	Authentication	Authentication and Access control	Neither	
802.1X (VSC)	Wireless + wired* users authenticated via: <ul style="list-style-type: none">• Local user accounts• External RADIUS server• Active Directory	Wireless + wired* users authenticated via: <ul style="list-style-type: none">• Local user accounts• External RADIUS server• Active Directory	Wireless + wired users authenticated via: <ul style="list-style-type: none">• External RADIUS server	“Configuring 802.1X support on a VSC” (page 336) .
802.1X (Switch port)	Only supported when the switch port is not bound to a VSC. Supports wired users only.			“Configuring 802.1X support on an HP 517 or MSM317 switch port” (page 339) .
MAC-based (Global)	Not supported	Wireless + wired* users authenticated via: <ul style="list-style-type: none">• Local user accounts• External RADIUS server• Active Directory	Not supported	“Configuring global MAC-based authentication” (page 341) .
MAC-based (VSC)	Wireless users authenticated via: <ul style="list-style-type: none">• Local user accounts• External RADIUS server• Active Directory	Wireless users authenticated via: <ul style="list-style-type: none">• Local user accounts• External RADIUS server• Active Directory	Wireless + wired users authenticated via: <ul style="list-style-type: none">• External RADIUS server	“Configuring MAC-based authentication on a VSC” (page 342) .
MAC-based (Switch port)	Only supported when the switch port is not bound to a VSC. Supports wired users only.			“Configuring MAC-based authentication on an HP 517 or MSM317 switch port” (page 343) .

Auth type	The <i>Use controller</i> for option in a VSC is set to:			For more information, see ...
	Authentication	Authentication and Access control	Neither	
HTML-based	Not supported	Wireless users authenticated via: <ul style="list-style-type: none"> Local user accounts on the controller External RADIUS server Active Directory 	Not supported	"Configuring HTML-based authentication on a VSC" (page 348).
VPN-based	Not supported	Wireless + wired* users authenticated via: <ul style="list-style-type: none"> Local user accounts on the controller External RADIUS server Active Directory 	Not supported	"Configuring VPN-based authentication on a VSC" (page 350)
No authentication	Wireless + wired users*			"No authentication" (page 350).

* *Wired users are only supported on the default VSC, unless their traffic is on a VLAN that matches the VSC ingress defined on another VSC. (On a controller team, wired users are only supported via the HP 517 or MSM317 switch ports.)*

Other access control methods

Although not authentication options, the following features can also be used to limit access to the network.

Feature	Applies to	For more information, see ...
MAC lockout (Global)	Wireless/wired users connected via: <ul style="list-style-type: none"> Wireless ports on controlled APs Wired ports (including switch ports) on controlled APs Local mesh ports on controlled APs The LAN port on the controller MAC lockout does not apply to the Internet port (Internet network on the MSM720) on the controller.	"Configuring global MAC lockout" (page 344).
Wireless MAC filter (VSC)	Wireless users connected via wireless ports on controlled APs.	"MAC-based filtering" (page 340). "Configuring MAC-based filters on a VSC" (page 344). "Configuring MAC-based filters on an HP 517 or MSM317 switch port" (page 345).
Wireless IP filter (VSC)	Wireless users connected via wireless ports on controlled APs.	"Wireless IP filter" (page 134).

Using more than one authentication type at the same time

For added flexibility, you can enable multiple authentication types on a VSC at the same time to support users with different needs. How this works depends on setting of the **Use Controller for**

option in the VSC. The following table lists all possible combinations of authentication types (and other features) that can be activated, and shows the order in which they are applied.

The <i>Use controller for</i> option in a VSC is set to:		
Authentication	Authentication and Access control	Neither
<ul style="list-style-type: none"> MAC lockout + Wireless MAC filter + MAC-based (VSC) + 802.1X (VSC) 	<ul style="list-style-type: none"> MAC lockout + Wireless MAC filter + MAC-based (Global) + HTML-based <i>or</i> MAC lockout + Wireless MAC filter + 802.1X <i>or</i> MAC lockout + Wireless MAC filter + MAC-based (VSC) MAC lockout + VPN-based (VSC) 	<ul style="list-style-type: none"> MAC lockout + Wireless MAC filter + MAC-based (VSC) + 802.1X (VSC)

When MAC-based authentication and 802.1X authentication are enabled

Clients stations only gain access when they are successfully authenticated by both methods. If one method fails, then access is denied.

When Wireless MAC filter is used alone or with other authentication methods

The following table describes how the MAC filter functions when it is used alone and in combination with other authentication options:

Client address	Filter action	When used alone	When used with MAC-based authentication	When used with 802.1X authentication
Client address is in the MAC address list.	Allow	Access is granted.	Access is granted. MAC-based authentication is not performed.	Access is granted or denied based on result of 802.1X authentication.
Client address is in the MAC address list.	Block	Access is denied.	Access is denied. MAC-based authentication is not performed.	Access is denied.
Client address is not in the MAC address list.	Allow	Access is denied.	Access is granted or denied based on result of MAC-based authentication. (Not supported on access-controlled VSCs.)	Access is granted or denied based on result of 802.1X authentication.
Client address is not in the MAC address list.	Block	Access is granted.	Access is granted or denied based on result of MAC-based authentication.	Access is granted or denied based on result of 802.1X authentication.

Switch port not bound to a VSC

When a switch port is not bound to a VSC, the following authentication options are supported:

- 802.1X (Switch port)
- MAC-based (Switch port)

If both options are enabled at the same time, then:

- 802.1X takes priority for client stations that are 802.1X enabled. If 802.1X authentication fails, MAC authentication is not checked and the client station fails to authenticate.
- MAC authentication takes priority for client stations that are not 802.1X enabled. If MAC authentication fails, then the client station fails to authenticate.

User authentication limits

The following limits apply:

Controller	Maximum number of controlled APs	Maximum number of locally defined user accounts	Maximum number of active user sessions
MSM720	40	1000	250
MSM760	200	2000	2000
MSM765 zl, MSM775 zl	200	2000	2000
Controller Team (MSM720)	40	1000	250
Controller Team (MSM760, MSM765 zl, MSM775 zl)	800	2000	2000

802.1X authentication

802.1X is a popular protocol for user authentication that is natively supported on most client stations. 802.1X authentication can be configured at different levels as described in the following table.

VSC	Switch port
Authentication tasks are managed by either the controller or the AP. (Depends on how the VSC is configured.)	Authentication tasks are managed by the HP 517 or MSM317.
Applies to wireless and wired users.	Applies to wired users only.
Settings are defined on a per-VSC basis.	Settings are defined on a per-port basis.
Can be used on access-controlled and non-access-controlled VSCs.	Can only be used when a switch port is not bound to a VSC.
Configured using the Add/Edit Virtual Service Community configuration page in the management tool.	Configured by selecting Controlled APs > [HP 517 or MSM317 AP] >> Configuration > Switch ports > [switch-port] in the management tool.

VSC	Switch port
User credentials can be validated using: <ul style="list-style-type: none"> Local user accounts on the controller External RADIUS server Active Directory (Depends on how the VSC is configured.)	User credentials can be validated using: <ul style="list-style-type: none"> External RADIUS server
See: <ul style="list-style-type: none"> “Configuring 802.1X support on a VSC” (page 336). “Configuring global 802.1X settings for wired users” (page 338). “Configuring global 802.1X settings for wired users” (page 338). 	See “Configuring 802.1X support on an HP 517 or MSM317 switch port” (page 339).

Supported 802.1X protocols

The following table lists the 802.1X protocols supported by the internal RADIUS server on the controller, and when using a third-party RADIUS server.

Protocol	Local user accounts (via Internal RADIUS server)	Third-party RADIUS server	Certificates required
EAP-MD5	×	✓	No
EAP-TLS	✓	✓	Client and Server
EAP-TTLS	✓	✓	Server
LEAP	×	✓	No
PEAPv0	✓	✓	Server
PEAPv1	×	✓	Server
EAP-FAST	×	✓	Optional
EAP-SIM	×	✓	Server
EAP-AKA	×	✓	Server

The EAP protocols in this table are known to work with the controller. Other EAP protocols may also work but have not been tested. EAP-MD5 is supported with third-party RADIUS servers for 802.1X authentication for VSCs without wireless encryption.

Protocol definitions

The following are brief definitions for the supported protocols. For more detailed information, see the appropriate RFC for each protocol.

- EAP-MD5:** Extensible Authentication Protocol Message Digest 5. Offers minimum security. EAP-MD5 does not support key generation, which makes it unsuitable for dynamic WEP, WPA or WPA2. Not recommended.
- EAP-TLS:** Extensible Authentication Protocol Transport Layer Security. Provides strong security based on mutual authentication. Requires both client and server-side certificates.
- EAP-TTLS:** Extensible Authentication Protocol Tunneled Transport Layer Security. Provides excellent security with less overhead than TLS as client-side certificates can be used, but are not required.
- LEAP:** Lightweight Extensible Authentication Protocol. Provides mutual authentication between a wireless client and the RADIUS server. Supports WEP, TKIP, and WPA2 keys.

NOTE: LEAP is not supported on access-controlled VSCs.

- PEAPv0: Protected Extensible Authentication Protocol. One of the most supported implementations across all client platforms. Uses MSCHAPv2 as the inner protocol.
- PEAPv1: Protected Extensible Authentication Protocol. Alternative to PEAPv0 that permits other inner protocols to be used.
- EAP-FAST: Extensible Authentication Protocol Flexible Authentication via Secure Tunneling. Can use a pre-shared key instead of server-side certificate.

Configuring 802.1X support on a VSC

Each VSC can have unique settings for 802.1X authentication. These settings are defined on the VSC profile page. (To open this page, see “[Viewing and editing VSC profiles](#)” (page 112)).

- When the **Use controller for Authentication** option is enabled under **General**, 802.1X authentication tasks are handled by the controller. APs forward all authentication requests to the controller which validates user login credentials using the local user accounts or a third-party authentication server (RADIUS or Active Directory).

Global ?

Profile name:

Use Controller for: Authentication
 Access control

802.1X authentication ?

Authentication

Local
 Remote

Active directory
 RADIUS:
 Request RADIUS CUI

General

RADIUS accounting:

 Called-Station-Id content:

- When the **Use controller for Authentication** option is disabled under **General**, 802.1X authentication tasks are handled directly by the AP. The AP uses the services of a third-party RADIUS server (configured by defining a RADIUS profile on the **Controller >> Authentication > RADIUS profiles** page) to validate user login credentials.

Global ?

Profile name:

Use Controller for: Authentication
 Access control

802.1X authentication ?

Authentication

RADIUS profile:

General

RADIUS accounting:

 Called-Station-Id content:

NOTE: When the **Wireless protection** option in a VSC is set to **WPA** with a **Key source** of **Dynamic**, 802.1X is automatically enabled.

Wireless protection WPA ?
 Mode*: WPA (TKIP)
 Key source: Dynamic
 Terminate WPA at the controller
*On radios in pure 802.11n mode WPA2 is always used instead of WPA

802.1X authentication ?

Authentication
 Local
 Remote

General
 RADIUS accounting:
 RADIUS server 1

Authentication

Local

User logins are authenticated with the list defined on the **Controller >> Users > User accounts** page. Local user accounts use the authentication services of the internal RADIUS server which supports the following 802.1X protocols: EAP-TLS, EAP-TTLS, and PEAPv0. Other protocols may work but have not been tested.

Remote

- **Active Directory:** User logins are authenticated via Active Directory. To setup Active Directory support go to the **Controller >> Security > Active Directory** page.
- **RADIUS:** User logins are authenticated via an external RADIUS server. The following 802.1X protocols are supported: EAP-MD5, EAP-TLS, EAP-TTLS, LEAP, PEAPv0, PEAPv1, EAP-FAST, EAP-SIM, and EAP-AKA. (EAP-MD5 is not supported on VSCs that have WEP with dynamic keys enabled.) Other protocols may work but have not been tested. To setup the connection to an external RADIUS server, go to the **Controller >> Authentication > RADIUS profiles** page.
 - **Request RADIUS CUI:** Enable this option to support the Chargeable User Identity (CUI) attribute as defined in RFC-4372. The CUI is used to associate a unique identifier with a user so that the user can be identified (for billing, authentication or other purposes) when roaming outside of their home network.

General

RADIUS accounting

Enable this option to have the controller generate a RADIUS START/STOP and interim request for each user. The controller respects the RADIUS interim-update-interval attribute if present inside the RADIUS access accept of the authentication.

Called-Station-ID content

(Only available when **Access control** is disabled under **Global**.)

Select the value that the AP (with which the user has established a wireless connection) will return as the called station ID.

- **Port 1:** MAC address of the first Ethernet port on the AP.
- **Port 2:** MAC address of the second Ethernet port on the AP. (Not supported on all APs.)
- **Wireless Radio:** MAC address of the wireless radio on the AP on which this VSC is operating.

- **BSSID:** Basic service set ID of the wireless network defined for this VSC.
- **macaddress:ssid:** The MAC address of the AP radio, followed by a colon, followed by the SSID configured on this VSC.

Configuring global 802.1X settings for wired users

Configure global 802.1X settings by selecting **Controller >> Authentication > 802.1X**.

The screenshot shows the '802.1X configuration' window. Inside, there is a 'Global 802.1X settings' panel with the following fields:

- Supplicant timeout: 3 seconds
- Reauthentication
 - Period: 1 hour (dropdown menu)
 - Terminate:

A 'Save' button is located at the bottom right of the configuration window.

These settings only apply to:

- Wired clients connected to the controller via the LAN port.
- Wireless clients using an access-controlled VSC with **Wireless protection** set to **WPA** and the **Terminate WPA at the controller** option enabled. See [“Terminate WPA at the controller”](#) (page 129).

These settings do not apply to clients connected to the switch port on the HP 517 or MSM317.

Supplicant timeout

Specify the maximum length of time that the controller will wait for a client station to respond to an EAPOL packet before resending it.

If client stations are configured to manually enter the 802.1X username and/or the password, you must increase the value of the timeout to between 15 and 20 seconds.

Reauthentication

Enable this option to force 802.1X clients to re-authenticate after the specified **Period**.

- **Period:** Client stations must re-authenticate after this amount of time has passed since their last reauthentication.
- **Terminate**
 - **Disabled:** Client stations remain connected during re-authentication and client traffic is blocked only when re-authentication fails.
 - **Enabled:** Client traffic is blocked during re-authentication and is only activated again if authentication succeeds.

Configuring global 802.1X settings for wireless users

Global 802.1X settings for wireless users connected to controlled APs are defined by selecting **Controlled APs >> Configuration > 802.1X**.

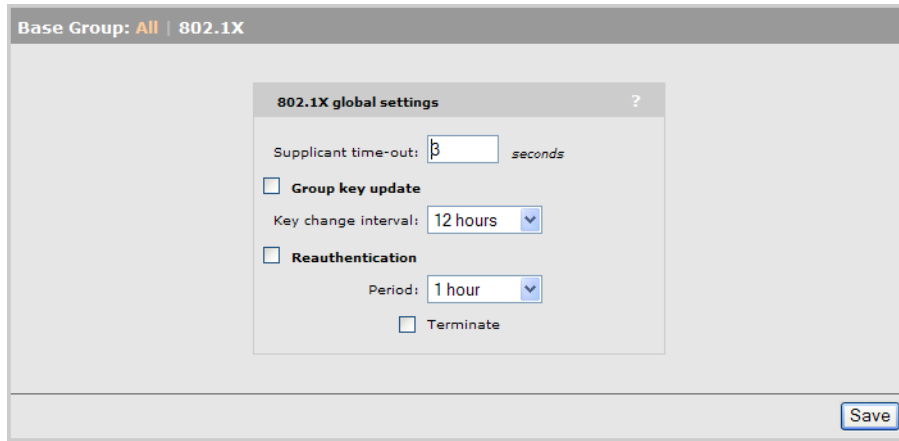

Supplicant timeout

Specify the maximum length of time for the to wait for a client station to respond to an EAPOL packet before resending it.

EAPOL (Extensible Authentication Protocol over LAN) is used for 802.1X port access control. 802.1X can be used to authenticate at "network connect time" when using either wired or wireless LAN adapters.

If client stations are configured to manually enter the 802.1X username or password or both, increase the value of the timeout to 15 to 20 seconds.

Group key update

Enable this option to force updating of 802.1X group keys at the specified **Key change interval**.

Reauthentication

Enable this option to force 802.1X clients to reauthenticate.

Period

Specify the interval at which client stations must reauthenticate.

Terminate

- **Disabled:** Client station remains connected during reauthentication. Client traffic is blocked only when reauthentication fails.
- **Enabled:** Client traffic is blocked during reauthentication and is only reactivated if authentication succeeds.

Configuring 802.1X support on an HP 517 or MSM317 switch port

If a switch on the HP 517 or MSM317 port is not bound to a VSC, then 802.1X can be enabled on it.

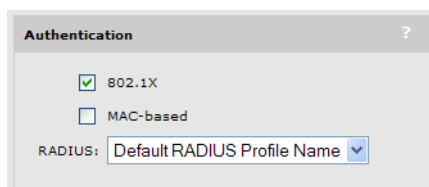

802.1X authentication tasks are handled by the HP 517 or MSM317. The HP 517 or MSM317 uses the services of a third-party RADIUS server (configured by defining a RADIUS profile on the **Controller >> Authentication > RADIUS profiles** page) to validate user login credentials.

MAC-based authentication

MAC-based authentication can be used to automatically authenticate wired or wireless devices as soon as they appear on the network, eliminating the need for manual login. This is useful for

authenticating devices that do not have a Web browser and are permanently installed on a network (a printer or point-of-sale terminal, for example), but can also be used for regular users.

MAC authentication can be configured at several different levels as described in the following table.

Global	VSC	Switch port
Authentication is handled by the controller.	Authentication is handled by either the controller or the AP. (Depends on how the VSC is configured.)	Authentication is handled by the HP 517 or MSM317.
Applies to both wireless and wired users.	Applies to wireless users if the VSC is configured for either Authentication and/or Access control. If neither are configured, applies to both wireless and wired users.	Applies to wired users only.
Settings apply globally to all VSCs, except for the authentication server which is defined on a per-VSC basis.	Settings are defined on a per-VSC basis.	Settings are defined on a per-port basis.
Can only be used on access-controlled VSCs that have HTML-based user logins enabled.	Can be used on non-access-controlled VSCs, or on access-controlled VSCs that have HTML-based user logins disabled.	Can only be used when the switch port is not bound to a VSC.
Configured using a RADIUS attribute or local public access attribute.	Configured using the Add/Edit Virtual Service Community configuration page in the management tool.	Configured by selecting Controlled APs > [HP 517 or MSM 317 AP] >> Configuration > Switch ports > [switch-port] in the management tool.
User credentials can be validated using: <ul style="list-style-type: none"> Local user accounts on the controller External RADIUS server Active Directory 	User credentials can be validated using: <ul style="list-style-type: none"> Local user accounts on the controller External RADIUS server (Depends on how the VSC is configured.)	User credentials can be validated using: <ul style="list-style-type: none"> External RADIUS server
See "Configuring global MAC-based authentication" (page 341).	See "Configuring MAC-based authentication on a VSC" (page 342).	See "Configuring MAC-based authentication on an HP 517 or MSM317 switch port" (page 343).

MAC-based filtering

In addition, MAC-based filters can also be used to manage access to the network.

VSC	Switch port
Filtering occurs on the AP wireless interfaces.	Filtering occurs individually on each HP 517 or MSM317 switch port.
Applies to wireless client stations only.	Applies to wired client stations only.
Settings are defined on a per-VSC basis.	Settings are defined on a per-port basis.
Can be used on both access-controlled and non-access-controlled VSCs.	Can only be used when the switch port is not bound to a VSC.
Configured using the Add/Edit Virtual Service Community configuration page in the management tool.	Configured by selecting Controlled APs > [HP 517 or MSM317] >> Configuration > Switch ports > [switch-port] in the management tool.

VSC	Switch port
MAC addresses are validated against a custom list for each VSC.	MAC addresses are validated against a global list that is defined on the controller and applies across all devices.
See “Configuring MAC-based filters on a VSC” (page 344) .	See “Configuring MAC-based filters on an HP 517 or MSM317 switch port” (page 345) .

NOTE: MAC-based filter are always applied before MAC-based authentication.

Configuring global MAC-based authentication

You define global MAC-based authentication settings using the Colubris-AVPair value string `mac-address`, which you must add to the RADIUS account for the controller. See [“Global MAC-based authentication” \(page 476\)](#).

Although the global MAC-based authentication settings apply to all VSCs that have HTML-based user logins enabled, each VSC can use a different authentication server to validate user credentials. To define an authentication server for a VSC, open the **Add/Edit Virtual Service Community** page and use the **HTML-based user logins** box to select the authentication method. See [“HTML-based user logins” \(page 132\)](#).

MAC authentication is performed before HTML authentication. If MAC authentication fails, the users connection is terminated. If it succeeds, and HTML authentication is enabled, HTML authentication is performed next.

Configuring MAC-based authentication on a VSC

Each VSC can have unique settings for MAC authentication of wireless client stations. These settings are defined on the VSC profile page. (To open this page, see [“Viewing and editing VSC profiles” \(page 112\)](#)).

- When the **Use Controller for Authentication** option is enabled under **Global**, MAC-based authentication tasks are managed by the controller. APs forward all authentication requests to the controller which validates user login credentials using the local user accounts or a third-party RADIUS server. (If the **Access control** option is also enabled, then MAC-based authentication cannot be used as the same time as HTML-based user logins.)

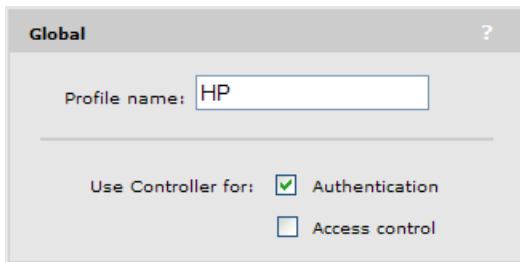

Global ?

Profile name:

Use Controller for: Authentication
 Access control

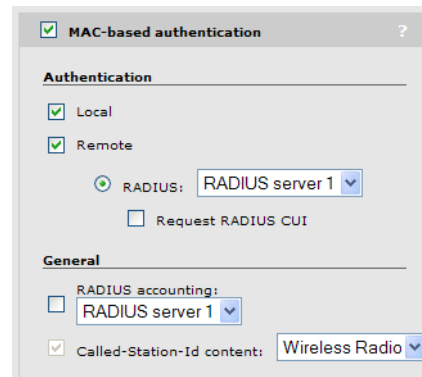

MAC-based authentication ?

Authentication

Local
 Remote

RADIUS:
 Request RADIUS CUI

General

RADIUS accounting:
 Called-Station-Id content:

- When the **Use Controller for Authentication** option is disabled under **Global**, MAC-based authentication tasks are managed by the AP. The AP uses the services of a third-party RADIUS server (configured by defining a RADIUS profile on the **Controller >> Authentication > RADIUS profiles** page) to validate user login credentials.

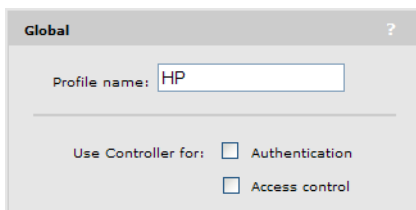

Global ?

Profile name:

Use Controller for: Authentication
 Access control

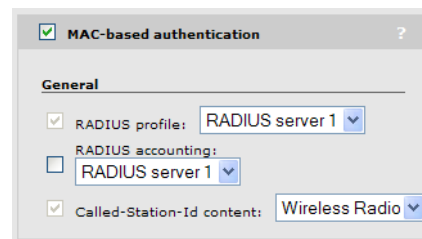

MAC-based authentication ?

General

RADIUS profile:
 RADIUS accounting:
 Called-Station-Id content:

NOTE: Reauthentication of client stations does not automatically occur upon session timeout.

Authentication

Local

User logins are authenticated with the list defined on the **Controller >> Users > User accounts** page. Define both the username and password as the MAC address of the device. Use the MAC address format defined on the **Controller >> Authentication > MAC format** page. See [“Configuring MAC address format” \(page 347\)](#).

Remote

User logins are authenticated via an external RADIUS server. To define the connection to an external RADIUS server, go to the **Controller >> Authentication > RADIUS profiles** page.

To successfully authenticate a client station, an account must be created on the RADIUS server with both username and password set to the MAC address of the client station.

The MAC address sent by the controller or controlled AP in the RADIUS REQUEST packet for both username and password is 12 hexadecimal numbers in the format defined on the **Controller >> Authentication > MAC format** page. See “[Configuring MAC address format](#)” (page 347).

The RADIUS server will reply to the REQUEST with either an ACCEPT or REJECT RADIUS RESPONSE packet. In the case of an ACCEPT, the RADIUS server can return the session-timeout RADIUS attribute (if configured for the account). This attribute indicates the amount of time, in seconds, that the authentication is valid for. When this period expires, the controller or controlled AP will re-authenticate the wireless station.

- **Request RADIUS CUI:** Enable this option to support the Chargeable User Identity (CUI) attribute as defined in RFC-4372. The CUI is used to associate a unique identifier with a user so that the user can be identified (for billing, authentication or other purposes) when roaming outside of their home network.

General

RADIUS accounting

Enable this option to have the controller generate a RADIUS START/STOP and interim request for each user. The controller respects the RADIUS interim-update-interval attribute if present inside the RADIUS access accept of the authentication.

Called-Station-ID content

(Only available when **Access control** is disabled under **Global**)

Select the value that the AP (with which the user has established a wireless connection) will return as the called station ID.

- **Port 1:** MAC address of the first Ethernet port on the AP.
- **Port 2:** MAC address of the second Ethernet port on the AP. (Not supported on all APs.)
- **Wireless Radio:** MAC address of the wireless radio on the AP on which this VSC is operating.
- **BSSID:** Basic service set ID of the wireless network defined for this VSC.
- **macaddress:ssid:** The MAC address of the AP radio, followed by a colon, followed by the SSID configured on this VSC.

Configuring MAC-based authentication on an HP 517 or MSM317 switch port

If a switch port on the HP 517 or MSM317 is not bound to a VSC then MAC-based authentication can be enabled on the switch port. Select **Controlled APs > [HP 517 or MSM317 AP] >> Configuration > Switch ports > [switch-port]** in the management tool.

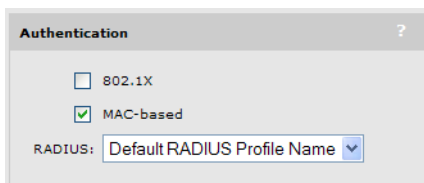

The screenshot shows a configuration window titled "Authentication" with a question mark icon. It contains two checkboxes: "802.1X" (unchecked) and "MAC-based" (checked). Below these is a "RADIUS:" label followed by a dropdown menu currently set to "Default RADIUS Profile Name".

MAC authentication tasks are handled by the HP 517 or MSM317. The HP 517 or MSM317 uses the services of a third-party RADIUS server (configured by defining a RADIUS profile on the **Controller >> Authentication > RADIUS profiles** page) to validate user login credentials.

Configuring global MAC lockout

This feature lets you block traffic from client stations based on their MAC address. MAC lockout applies to globally to all client stations connected to:

- Wireless ports on controlled APs
- Wired ports (including switch ports) on controlled APs
- Local mesh ports on controlled APs
- The LAN port (Access network on the MSM720) on the controller

NOTE: MAC lockout does not apply to the Internet port (Internet network on the MSM720).

To configure MAC lockout, select **Controller >> Security > MAC lockout**.

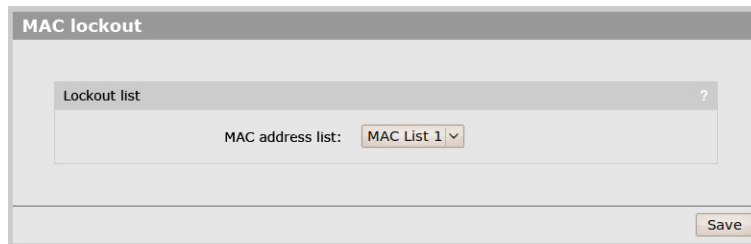

Select the MAC address list that will be used to lockout client stations. If a client station's MAC address appears in the list it will be blocked from using the network. Up to 64 MAC addresses can be defined in a list for use with MAC lockout. Define lists by selecting **Controller >> Security > MAC lists**.

Configuring MAC-based filters on a VSC

The Wireless MAC filter option enables you to control access to the wireless network based on the MAC address of a wireless device. You can either block access or allow access, depending on your requirements.

This feature is configured on the VSC profile page. (To open this page, see [“Viewing and editing VSC profiles”](#) (page 112)).

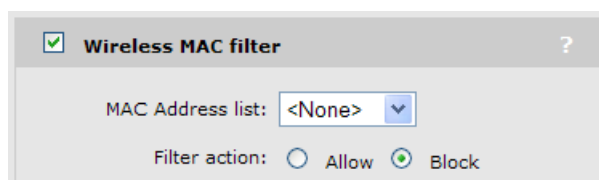

MAC address list

Select the MAC address list to check when the Wireless MAC filter option is enabled. If the MAC address of a client station appears in the list, then the selected Filter action is applied. Define lists by selecting **Security > MAC lists**.

Filter action

The following table describes how the wireless MAC filter functions when it is used alone and in combination with other authentication options:

Client address	Filter action	When used alone	When used with MAC-based authentication	When used with 802.1X authentication
Client address is in the MAC address list.	Allow	Access is granted.	Access is granted. MAC-based authentication is not performed.	Access is granted or denied based on result of 802.1X authentication.
Client address is in the MAC address list.	Block	Access is denied.	Access is denied. MAC-based authentication is not performed.	Access is denied.
Client address is not in the MAC address list.	Allow	Access is denied.	Access is granted or denied based on result of MAC-based authentication. (Not supported on access-controlled VSCs.)	Access is granted or denied based on result of 802.1X authentication.
Client address is not in the MAC address list.	Block	Access is granted.	Access is granted or denied based on result of MAC-based authentication.	Access is granted or denied based on result of 802.1X authentication.

Configuring MAC-based filters on an HP 517 or MSM317 switch port

This option lets you control port access based on client station MAC addresses. Addresses are checked against one or more lists stored on the controller. If the MAC address of a connected device appears in any configured list, then the device is permitted to send and receive traffic on the port.

To configure MAC-based filters on an HP 517 or MSM317 switch port, do the following:

1. Select **Controlled APs > [HP 517 or MSM317 AP] >> Configuration > Switch ports > [switch-port]** in the management tool.
2. Select the **MAC filter** checkbox.

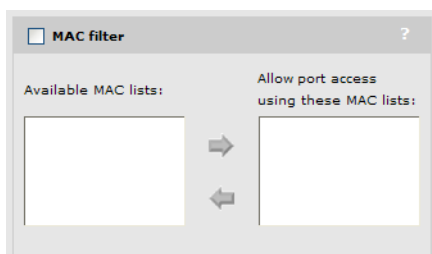

3. Under **Available MAC lists**, select each MAC list you want to use and select the right arrow icon to move it under **Allow port access using these MAC lists**.
4. Select **Save**.

Configuring MAC address lists

MAC lists are used by several options to allow/deny access to client stations. You can define up to 75 MAC address lists with up to 256 entries in each list. The lists can be used to define MAC addresses for the following features:

- The **MAC filter** option on a switch port (**Controlled APs >> Configuration > Switch ports**), permitting you to limit switch port access to a specific devices based on their MAC address. When used with this feature, a maximum of 256 addresses are supported per list.
- The **Wireless MAC filter** option in a VSC. When used with this feature, a maximum of 256 addresses are supported per list.
- The **MAC lockout** feature. When used with this feature, a maximum of 64 addresses are supported per list.

The total number of MAC addresses defined for all lists cannot exceed 4800.

To define a MAC list, do the following:

1. Select **Controller >> Security > MAC lists**.

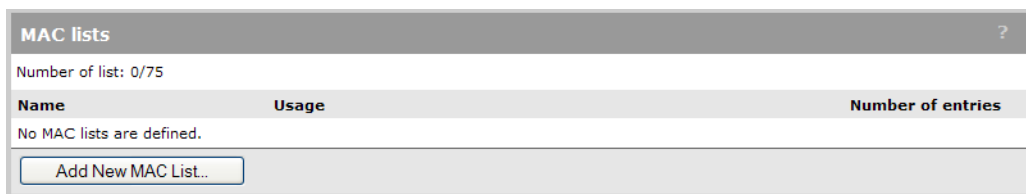

The screenshot shows the 'MAC lists' configuration page. At the top, it says 'MAC lists' with a help icon. Below that, it indicates 'Number of list: 0/75'. There is a table with three columns: 'Name', 'Usage', and 'Number of entries'. The table is currently empty, with the text 'No MAC lists are defined.' below it. At the bottom, there is a button labeled 'Add New MAC List...'.

2. Select **Add New MAC List**. The Add/Edit MAC list page opens.

Each entry in the MAC list contains a MAC address and its associated mask. By varying the mask, an entry can be defined to match a single address or a range of addresses.

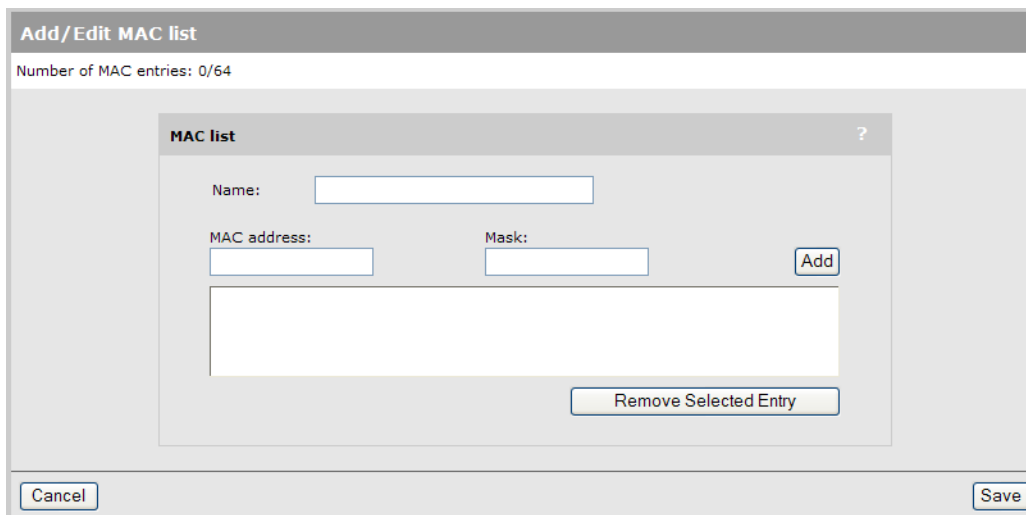

The screenshot shows the 'Add/Edit MAC list' page. At the top, it says 'Add/Edit MAC list' with a help icon. Below that, it indicates 'Number of MAC entries: 0/64'. The main area contains a 'MAC list' form with a 'Name' field, 'MAC address' and 'Mask' fields, and an 'Add' button. Below the form is a 'Remove Selected Entry' button. At the bottom of the page, there are 'Cancel' and 'Save' buttons.

3. Specify a **Name** to identify the MAC address list.
4. Specify the **MAC address** and **Mask** that you want to match, then select **Add**. Setting the **Mask** to **00:00:00:00:00:00** is allowed, but not recommended since it will match all MAC addresses.
5. Repeat step 4 until you have defined all needed entries.
6. Select **Save**.

Matching MAC addresses

Matching a single MAC address

To match a single MAC address, specify the address using 12 hexadecimal numbers in the format: **nn:nn:nn:nn:nn:nn**, and set the **Mask** to: **FF:FF:FF:FF:FF:FF**

For example, this definition matches a single MAC address:

MAC address = 00:03:52:07:2B:43

Mask = FF:FF:FF:FF:FF:FF

Matching a range of MAC addresses

To match a range of MAC addresses, you need to use the wildcard feature. A value of **00** in a mask means that the corresponding position in the address is a wildcard (i.e., it can be any value).

For example, to match all address that begin with the prefix 00:03:52 you would define:

MAC address = 00:03:52:00:00:00

Mask = FF:FF:FF:00:00:00

Wildcards can be placed anywhere (but must always be 00, half-byte masks such as F0 are not supported). Multiple wildcards can be used.

For example, this entry matches all the addresses that have their first three bytes set to 00:03:52 and the final bytes set to AA:FF

MAC address = 00:03:52:00:AA:FF

Mask = FF:FF:FF:00:FF:FF

Configuring MAC address format

Select **Controller >> Authentication > MAC format** to define the format to use for MAC addresses.

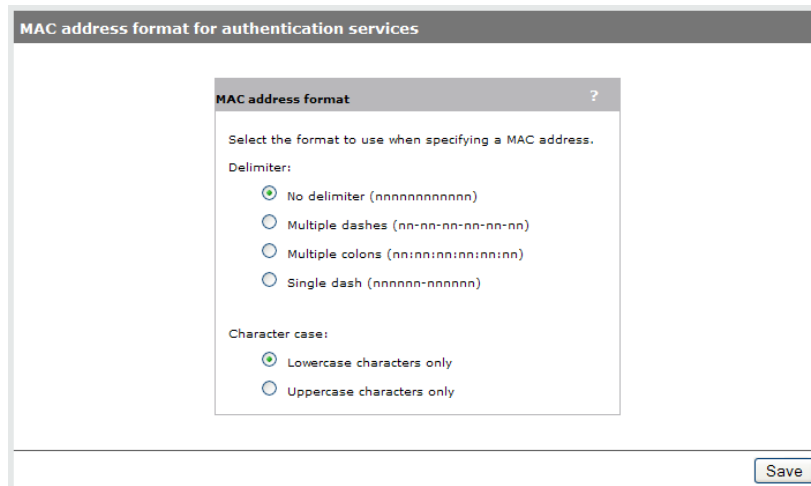

This format applies to the following features only:

- MAC addresses defined in a user account (**Controller >> Users > User accounts**)
- MAC addresses sent to a remote RADIUS server.

HTML-based authentication

HTML-based authentication is used with the public/guest access feature described in [“Public/guest network access” \(page 396\)](#). It enables users to login to the public access interface using a standard Web browser.

HTML-based authentication has the following properties:

- Authentication is handled by the controller.
- Settings are defined on a per-VSC basis.
- Can only be used on access-controlled VSCs.
- Configured using the **Add/Edit Virtual Service Community** configuration page in the management tool.
- User credentials can be validated using:
 - Local user accounts on the controller
 - External RADIUS server
 - Active Directory

See “[Configuring global access control options](#)” (page 399) for more configuration settings that affect HTML-based users.

Configuring HTML-based authentication on a VSC

Each VSC can have unique settings for HTML-based user logins. These settings are defined on the VSC profile page. (To open this page, see “[Viewing and editing VSC profiles](#)” (page 112)).

When the **Use controller for Authentication** option is enabled under **General**, HTML-based user login options can be defined.

The screenshot shows the 'Global' configuration page for a VSC profile. The 'Profile name' field contains 'HP'. Under the 'Use Controller for:' section, both 'Authentication' and 'Access control' are checked.

The screenshot shows the 'HTML-based user logins' configuration page. Under the 'Authentication' section, 'Local' and 'Remote' are checked. 'Active directory' is unselected. 'RADIUS' is selected with a dropdown menu showing 'RADIUS server 1'. 'Request RADIUS CUI' is unselected. 'Authentication timeout' is set to 40. Under the 'General' section, 'RADIUS accounting' is unselected with a dropdown menu showing 'RADIUS server 1'.

Authentication

If both the **Local** and **Remote** options are active, the controller first checks the local user accounts (defined on the **Controller >> Users > User accounts** page). If the user does not appear in the list, then the controller queries the remote server (Active Directory or RADIUS).

Local

User logins are authenticated with the list defined on the **Controller >> Users > User accounts** page.

Remote

- **Active Directory:** User logins are authenticated via Active Directory. To setup Active Directory support go to the **Controller >> Security > Active Directory** page.
- **RADIUS:** User logins are authenticated via an external RADIUS server. To setup the connection to an external RADIUS server, go to the **Controller >> Authentication > RADIUS profiles** page.
 - **Request RADIUS CUI:** Enable this option to support the Chargeable User Identity (CUI) attribute as defined in RFC-4372. The CUI is used to associate a unique identifier with a user so that the user can be identified (for billing, authentication or other purposes) when roaming outside of their home network.
- **Authentication timeout:** Specify length of time (in seconds) that the controller will wait for the RADIUS server to respond to authentication requests. If the RADIUS server does not respond within this time period logins are refused.

General

- **RADIUS accounting:** Enable this option to have the controller generate a RADIUS START/STOP and interim request for each user. The controller respects the RADIUS interim-update-interval attribute if present inside the RADIUS access accept of the authentication.

VPN-based authentication

VPN-based authentication can be used to provide secure access for client stations on VSCs that do not have encryption enabled.

VPN-based authentication has the following properties:

- Authentication is managed by the controller.
- Applies to wireless and wired users.
- Settings are defined on a per-VSC basis.
- Can only be used on access-controlled VSCs.
- Configured using the **Add/Edit Virtual Service Community** configuration page in the management tool.
- User credentials can be validated using:
 - Local user accounts on the controller
 - External RADIUS server
 - Active Directory
- If you enable this option for a VSC, all wireless users on the VSC must establish a VPN connection. No other authentication methods (HTML, MAC, 802.1X) can be used on the VSC.
- When users configure their VPN software, they must specify the controller LAN port address as the address of the VPN server.
- To use this option, one or more of the following VPN features must be enabled and configured on the **Controller >> VPN** menu: L2TP server, PPTP server, or IPSec. Once this is done, VPN support can be enabled on a per-VSC basis and users can connect to any active VPN server.
- On the MSM760, MSM765 zl, and MSM775 zl, a maximum of 50 user sessions are supported across all VSCs.

Configuring VPN-based authentication on a VSC

Each VSC can have unique settings for VPN-based user logins. These settings are defined on the VSC profile page. (To open this page, see “Viewing and editing VSC profiles” (page 112)).

When the **Use controller for Authentication** and **Access control** options are enabled under **General**, VPN-based user login options can be defined.

The image shows two screenshots of the VSC configuration interface. The left screenshot is titled "Global" and shows a "Profile name" field with the value "HP". Below it, there are two checked options: "Use Controller for: Authentication" and "Access control". The right screenshot is titled "VPN-based authentication" and shows the "Authentication" section with "Local" and "Remote" checked, "Active directory" unselected, "RADIUS" selected and set to "RAD1", and "Request RADIUS CUI" unselected. Below that, the "General" section has "RADIUS accounting" unselected and set to "RAD1".

Authentication

Local

User logins are authenticated with the list defined on the **Controller >> Users > User accounts** page.

Remote

- **Active Directory:** User logins are authenticated via Active Directory. To setup Active Directory support go to the **Controller >> Security > Active Directory** page.
- **RADIUS:** User logins are authenticated via an external RADIUS server. To setup the connection to an external RADIUS server, go to the **Controller >> Authentication > RADIUS profiles** page.
 - **Request RADIUS CUI:** Enable this option to support the Chargeable User Identity (CUI) attribute as defined in RFC-4372. The CUI is used to associate a unique identifier with a user so that the user can be identified (for billing, authentication or other purposes) when roaming outside of their home network.

General

- **RADIUS accounting:** Enable this option to have the controller generate a RADIUS START/STOP and interim request for each user. The controller respects the RADIUS interim-update-interval attribute if present inside the RADIUS access accept of the authentication.

No authentication

For applications where a remote device performs all authentication functions, it can be useful to disable authentication on the controller and instead, forward all traffic on a VSC into an egress GRE tunnel or egress VLAN for authentication by the remote device.

NOTE: Because the controller routes traffic to the VSC egress, L2 information from the user is lost and only L3 information is available to the remote authentication device.

Locally-defined user accounts

The controller provides support for locally-defined user accounts with a wide range of customizable options. Locally-defined user accounts use the integrated RADIUS server. Configuration of these

accounts is done using the options on the **Controller >> Users** menu, which includes the following configuration pages: User accounts, Account profiles, Subscription plans, and Session persistence.

Each user account:

- Obtains account properties from one or more **account profiles**.
- Obtains account durations from one or more **subscription plans**.
- Is restricted for use with one or more **VSCs**.

Features

Access control

Two types of local user accounts are available: access-controlled and not access-controlled.

- Access-controlled accounts must be used with a VSC that is configured to provide access control.
- Non-access-controlled accounts must be used with a VSC that is *not* configured to provide access control. These accounts are used to handle authentication directly at the AP and cannot make use of the access control capabilities of the controller (the controller must not be in the traffic data path).

Validity and subscription plans

Each user account can be associated with a subscription plan that defines:

- The time period during which the account is available.
- The total amount of time a user can be online when logged in with the account.

VSC usage

User accounts can be restricted to specific VSCs. If the specified VSC is not available, then the user will not be able to connect with the account.

Account profiles

An account profile is used to define a specific set of features for a user account. Multiple account profiles can be applied to a user account allowing the feature sets of each profile to be added to the account.

NOTE: Each profile that is applied to a user account must have a unique feature set. The same feature cannot be present in two different profiles.

About the Default AC profile

The **Default AC profile** is defined by default, and is always applied to all access-controlled user accounts. You can view the settings for the **Default AC profile** by selecting it in the profile list. However, you cannot edit any of its settings directly. All settings for this profile are defined by setting attributes on the **Controller >> Public access > Attributes** page.

Supported attributes

The **Public access > Attributes** page allows a wide variety of attributes to be defined. However, only attributes that pertain to user configuration are applied to the **Default AC profile**. This includes the following attributes:

Attribute	For more info see
default-user-use-access-list	"Access list" (page 460).
default-user-welcome-url	"Default user URLs" (page 475).

Attribute	For more info see
default-user-goodbye-url	"Default user URLs" (page 475).
default-user-one-to-one-nat	"Default user one-to-one NAT" (page 474).
default-user-idle-timeout	"Default user idle timeout" (page 473).
default-user-session-timeout	"Default user session timeout" (page 474).
default-user-acct-interim-update	"Default user interim accounting update interval" (page 472).
default-user-max-output-packets	"Default user quotas" (page 473).
default-user-max-input-packets	"Default user quotas" (page 473).
default-user-max-total-packets	"Default user quotas" (page 473).
default-user-max-output-octets	"Default user quotas" (page 473).
default-user-max-input-octets	"Default user quotas" (page 473).
default-user-max-total-octets	"Default user quotas" (page 473).
default-user-max-input-rate	"Default user data rates" (page 124).
default-user-max-output-rate	"Default user data rates" (page 124).
default-user-bandwidth-level	"Default user bandwidth level" (page 473).
default-user-use-public-ip-subnet	"Default user bandwidth level" (page 473).

Example

This example illustrates how to indirectly customize the Default AC profile by defining several attributes, and shows how these settings are then reflected in a the Default AC profile and the user account.

The following sample page shows several attributes defined on the **Public access > Attributes** page under **Configured attributes**. The two of interest for this example are highlighted below.

Any change to the local site configuration will only get applied at the next reauthentication.

Retrieval of attributes

Retrieve attributes using RADIUS ?

RADIUS profile: Default RADIUS Profile Name ▾

RADIUS username:

RADIUS password:

Confirm RADIUS password:

Accounting

Retrieval settings ?

Retrieved attributes override configured attributes

Retrieval interval: minutes

Last retrieved: 0:00:22 ago

[Retrieve Now](#)

[Save](#)

Configured attributes ?

Attribute	Value	Action
ACCESS-LIST	factory,ACCEPT,all,*procurve.com,a...	↑ ↓ 🗑
ACCESS-LIST	factory,ACCEPT,all,*hp-ww.com,all	↑ ↓ 🗑
ACCESS-LIST	factory,ACCEPT,all,*windowsupdate...	↑ ↓ 🗑
USE-ACCESS-LIST	factory	🗑
DEFAULT-USER-IDLE-TIMEOUT	22	🗑
DEFAULT-USER-SESSION-TIMEOUT	100	🗑
VSA-WISPR-ACCESS-PROCEDURE	1.0	🗑

[Add New Attribute...](#)

These two attributes appear in the **Default AC** profile under **Session time attributes**:

Add/Edit account profile

General ?

Profile name:

Access-controlled profile

Egress interface ?

Egress VLAN:

Access-control features ?

VPN one-to-one-NAT: On Off

Legal interception: On Off

SMTP redirection:

Public IP address: On Off

Access list ?

List name:

Session time attributes ?

Reauthentication period: seconds

Termination action:

Idle timeout: seconds

Accounting interim interval: seconds

QoS parameters ?

Max output rate: Kbps

Max input rate: Kbps

Bandwidth level:

Station presence queries ?

Polling ARP interval: seconds

Polling max ARP count:

Advertising ?

Display advertisements: On Off

Custom attributes ?

Name	Type	Value	Move	Delete
No custom attributes are defined.				

And the attributes appear in access-controlled user accounts under **Effective attributes**:

Add/Edit user account

General

User name:

Password:

Confirm password:

Active

Access-controlled account

Account removal

Delete this account when

Invalid/expired for hours

Inactive for hours

Validity

Subscription plan:

Valid until:

(mm/dd/yyyy)

Always valid

Options

Max concurrent sessions:

Chargeable User Identity:

Idle timeout: seconds

Reauthentication period: seconds

Account profiles

Available profiles:

Set account attributes using these profiles:

➔ ➜

VSC usage

Available VSCs:

Restrict this account to these VSCs:

➔ ➜

Effective attributes

Attributes from the [default AC profile](#) are always applied.

Session timeout	100
Idle timeout	22

Defining a user account

1. Select **Controller >> Users > User accounts**. The User accounts page opens. It presents a list of all defined user accounts. Initially this list is empty.

User accounts

Select the action to apply to all listed user accounts:

Username	State	Access controlled	Subscription	Active sessions	Action
Add New Account...					

2. Select **Add New Account**. The Add/Edit user account page opens.

Add/Edit user account

General

User name:

Password:

Confirm password:

Active

Access-controlled account

Validity

Subscription plan:

Valid until:

Always valid

VSC usage

Available VSCs:

Restrict this account to these VSCs:

Account removal

Delete this account when

Invalid/expired for hours

Inactive for hours

Options

Max concurrent sessions:

Chargeable User Identity:

Idle timeout: seconds

Reauthentication period: seconds

Account profiles

Available profiles:

Set account attributes using these profiles:

Effective attributes

Attributes from the [default AC profile](#) are always applied.

No attributes defined

If you disable the **Access-controlled account** option, the page will look like this:

Add/Edit user account

General

User name:

Password:

Confirm password:

Active

Access-controlled account

VSC usage

Available VSCs:

Restrict this account to these VSCs:

Options

Chargeable User Identity:

Idle timeout: seconds

Egress VLAN ID:

Account profiles

Available profiles:

Set account attributes using these profiles:

Effective attributes

No attributes defined

3. Configure account options as described in the online help.

Defining account profiles

1. Select **Controller >> Users > Account profiles**. The Account profiles page opens. It presents a list of all defined profiles. Initially this list will contain the profile **Default AC**.

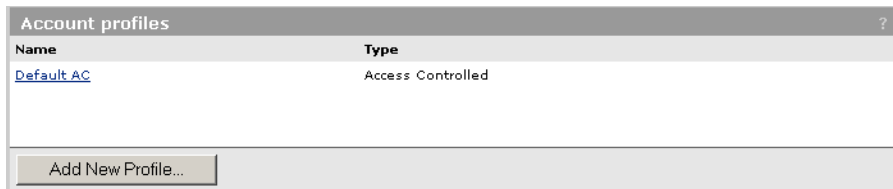

Name	Type
Default AC	Access Controlled

Add New Profile...

2. Select **Add New Profile**. The Add/Edit account profile page opens.

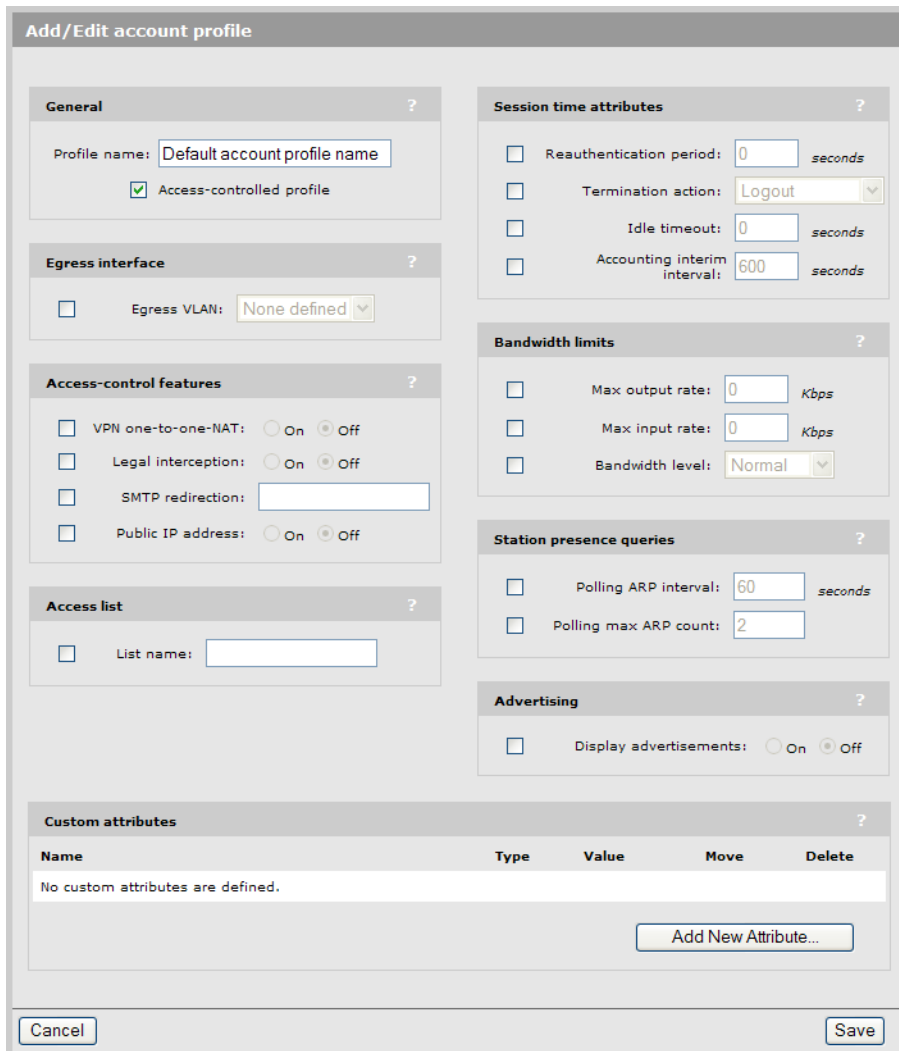

Add/Edit account profile

General

Profile name:

Access-controlled profile

Egress interface

Egress VLAN:

Access-control features

VPN one-to-one-NAT: On Off

Legal interception: On Off

SMTP redirection:

Public IP address: On Off

Access list

List name:

Session time attributes

Reauthentication period: seconds

Termination action:

Idle timeout: seconds

Accounting interim interval: seconds

Bandwidth limits

Max output rate: Kbps

Max input rate: Kbps

Bandwidth level:

Station presence queries

Polling ARP interval: seconds

Polling max ARP count:

Advertising

Display advertisements: On Off

Custom attributes

Name	Type	Value	Move	Delete
No custom attributes are defined.				

Add New Attribute...

Cancel Save

If you disable the **Access-controlled account** option, the page will look like this:

Add/Edit account profile

General ?

Profile name:

Access-controlled profile

Session time attributes ?

Reauthentication period: seconds

Termination action:

Idle timeout: seconds

Accounting interim interval: seconds

Egress interface ?

Egress VLAN ID:

Custom attributes ?

Name	Type	Value	Move	Delete
No custom attributes are defined.				

[Add New Attribute...](#)

Cancel
Save

3. Configure profile options as described in the online help.

Defining subscription plans

1. Select **Controller >> Users > Subscription plans**. The Subscription plans page opens. It presents a list of all defined subscription plans.

Subscription plans ?

Name	Online time	Validity period
Plan 1	60 Minutes	Always

[Add New Plan...](#)

2. Select **Add New Plan**. The Add/Edit subscription plan page opens.

Add/Edit subscription plan

General ?

Plan name:

Billing ?

Plan description:

Plan ID:

Plan fee: USD

Public IP address ?

Reserve public IP address

Advertising ?

Advertisements: On Off

Validity period ?

User account is valid

For after first login

Between and

From

Until

Online time ?

Duration:

Bandwidth level ?

Level:

Traffic quotas ?

Download limit: bytes

Upload limit: bytes

Total limit: bytes

3. Configure plan options as described in the online help.

Public IP address

This feature enables a public IP address to be assigned to any client station. This makes the client station address visible to devices on the external network, allowing external devices to create connections with the client station. For more information, see [“Assigning public IP addresses”](#) (page 47).

Accounting persistence

Enable this option to have the controller save accounting information to its internal flash memory so that can be recovered in case of abnormal system shutdown. Restarting the controller via its management tool (**Controller >> Maintenance > System**) saves before restarting.

The minimum save time is 30 minutes.

Accounting persistence

Accounting persistence ?

Save session information every minutes

Persistence status ?

Time elapsed since last persistent save: **00:31:43**

User addressing and related features

The controller provides a number of features related to user addressing, including:

Feature	Description	For more information, see ...
DHCP server	Enables the controller to dynamically assign IP addresses to users.	“Configuring the global DHCP server” (page 45)
Fixed leases	The controller assigns the same IP addresses to specific users each time they connect.	“Assigning fixed DHCP leases” (page 47)
DHCP relay	The controller to users a third-party DHCP server to dynamically assign IP addresses to users.	“Configuring the DHCP relay agent” (page 48)
NAT	Hides the IP addresses of all users on the protected network from the public network.	“Network address translation” (page 62)
Extend VSC egress subnet to VSC ingress subnet	Enables a third-party DHCP server to assign an IP address to users that makes them visible on the port mapped to a VSC egress.	“To configure the global DHCP relay agent” (page 48)
VPN one-to-one NAT	Assigns a unique IP address to each IPSec or PPTP VPN connection made by a user to a remote server via the Internet port.	“VPN one-to-one NAT” (page 515)
Public IP address	Assigns an IP address to users that makes them visible on the controller Internet port.	“Assigning public IP addresses” (page 47)

17 Authentication services

Introduction

This chapter explains how to configure the different authentication services that the controller can use to authenticate user logins and administrator logins. The following table summarizes the services that are available and what they can be used for.

Service	Description	For details, see ...
Integrated RADIUS server	User authentication via the local user lists.	“Using the integrated RADIUS server” (page 361)
Third-party RADIUS server	User authentication via accounts on a third-party RADIUS server. Administrator authentication via accounts on a third-party RADIUS server.	“Using a third-party RADIUS server” (page 364)
Active Directory	User authentication via an Active Directory server.	“Using an Active Directory server” (page 369)

All authentication services support the following authentication types:

Service	For details, see ...
802.1X (VSC)	“802.1X authentication” (page 334)
MAC-based (Global)	“MAC-based authentication” (page 339)
MAC-based (VSC)	“MAC-based authentication” (page 339)
HTML-based	“HTML-based authentication” (page 347)
VPN-based	“VPN-based authentication” (page 349)

When configuring 802.1X or MAC-based authentication on an HP 517 or MSM317 switch port, authentication services must be provided by a third-party RADIUS server. (For more information on each authentication type, see [“Configuring 802.1X support on an HP 517 or MSM317 switch port” \(page 339\)](#) and [“Configuring MAC-based authentication on an HP 517 or MSM317 switch port” \(page 343\)](#).)

Using the integrated RADIUS server

The internal RADIUS server is not intended as a replacement for the high-end/high-performance RADIUS server required for large scale deployments. Rather, it is offered as a cost-effective solution for managing user authentication for small hotspots or enterprise networks.

Primary features

- Provides termination of 802.1X sessions at the controller for clients using WPA/WPA2 with EAP-PEAP, EAP-TLS and EAP-TTLS. Support for other EAP protocols is available using proxy mode.
- Provides MAC-based authentication of wireless users connected to both controlled and autonomous APs.
- Can be used to validate login credentials for HTML-based users.
- All locally defined user account options (user accounts, account profiles, and subscription plans) presented on the **Controller >> Users** menu are handled by the internal RADIUS server.

- Allows RADIUS accounting data to be sent to an external RADIUS server. (The internal RADIUS server does not provide support for accounting.)
- Local user accounts and account profiles have been designed to match the same functionality and support as can be provided by an external RADIUS server. Most of the AVPairs supported on an external RADIUS server are also supported by the integrated RADIUS server.

Server configuration

Configuration of the integrated RADIUS server is done using the **Controller >> Authentication > RADIUS server** page. In most cases, the default settings on this page will not need to be changed.

The screenshot shows the 'RADIUS server/proxy' configuration page. It contains the following sections:

- RADIUS server:**
 - Detect SSID from NAS-Id
 - Number of accounting sessions:
 - Maximum accounting sessions: 500
 - Authentication UDP port: 1812
 - Accounting UDP port: 1813
- Server authentication support:**
 - PAP (Required to support MAC-based authentication in VSCs)
 - To support WPA clients you must select at least one of the following:
 - EAP-TTLS
 - EAP-PEAP
 - EAP-TLS
- RADIUS authorization:**
 - RADIUS authorization
 - The service controller will only reply to requests from RADIUS clients that are on this list.
 - Empty list box
 - IP address:
 - Mask:
 - Shared secret:
 -
- Default shared secret:**
 - Default shared secret
 - Shared secret:
 - Confirm shared secret:

A button is located at the bottom right of the page.

Configuration parameters

RADIUS server

Detect SSID from NAS-Id

Enable this option when working with third-party APs to permit the controller to retrieve the SSID assigned to the AP, and therefore assign user traffic to the appropriate VSC. For this to work, the AP must be configured to send its SSID as the NAS ID in all authentication and accounting requests. See [“Working with third-party autonomous APs”](#) (page 536).

Number of accounting sessions

Specify the maximum number of sessions for which the controller will track accounting information.

Maximum accounting sessions

Specify the maximum number of accounting sessions that the controller supports.

Authentication UDP port

Indicates the port the controller uses for authentication. This port is always set to the standard value of 1812.

Accounting UDP port

Indicates the port the controller uses for accounting. This port is always set to the standard value of 1813.

Server authentication support

Select the authentication protocols that the internal RADIUS server will support:

- PAP: This protocol must be enabled if any VSCs are configured to use MAC-based authentication or HTML authentication.
- EAP-TTLS
- EAP-PEAP
- EAP-TLS

RADIUS authorization

NOTE: Applies to autonomous and third-party APs. Requests from controlled APs are always accepted because they use the management tunnel.

Enable this option to restrict access to the RADIUS server. The RADIUS server will only respond to requests from RADIUS clients that appear in the list, or that match the default shared secret, as described below.

IP address

Specify the IP address of the RADIUS client. Specify the IP address of a single RADIUS client or the address of a subnet from which client will originate.

Mask

Specify the network mask for the IP address.

- If you are adding the IP address for a single RADIUS client, then use the mask 255.255.255.255.
- If you are adding the IP address for a subnet, then specify the mask appropriate for the subnet. For example, 255.255.255.0 for a Class-C subnet.

Shared secret

Specify the secret (password) that RADIUS client must use to communicate with the RADIUS server.

Default shared secret

NOTE: Applies to autonomous APs only. Requests from controlled APs are always accepted because they use the management tunnel.

Enable this option to set a shared secret to safeguard communications between the internal RADIUS server and clients not in the RADIUS authorization list.

Shared secret/Confirm shared secret

Specify the secret (password) that controller will use when communicating with RADIUS clients that do not appear in the RADIUS authorization list. The shared secret must match on both the clients and the controller.

User account configuration

User accounts for the internal RADIUS server are defined using the **Controller >> Users** menu. See [“User authentication, accounts, and addressing” \(page 331\)](#).

Using a third-party RADIUS server

A third-party RADIUS server can be used to perform a number of authentication and configuration tasks, as shown in the following table.

Task	For more information, see ...
Validating administrative user credentials.	"Setting up manager and operator accounts" (page 18).
Validating user credentials for 802.1X, MAC, MAC-based, and HTML—based authentication types.	"Wireless protection" (page 127). "HTML-based user logins" (page 132). "MAC-based authentication" (page 132).
Storing custom configuration settings for the public access interface.	"Working with RADIUS attributes" (page 435)
Storing custom configuration settings for each user.	
Storing accounting information for each user.	

The following authentication types can make use of an external third-party RADIUS server:

Service	For details, see ...
802.1X (VSC)	"802.1X authentication" (page 334)
MAC-based (Global)	"MAC-based authentication" (page 132)
MAC-based (VSC)	"MAC-based authentication" (page 132)
HTML-based	"HTML-based authentication" (page 347)
VPN-based	"VPN-based authentication" (page 349)

Configuring a RADIUS server profile

The controller enables you to define up to 64 RADIUS profiles (depending on the license that is installed). Each profile defines the settings for a RADIUS client connection. To support a client connection, you must create a client account on the RADIUS server. The settings for this account must match the profile settings you define on the controller.

For backup redundancy, each profile supports a primary and secondary server.

The controller can function with any RADIUS server that supports RFC 2865 and RFC 2866. Authentication occurs via authentication types such as: EAP-MD5, CHAP, MSCHAP v1/v2, PAP, EAP-TLS, EAP-TTLS, EAP-PEAP, EAP-SIM, EAP-AKA, EAP-FAST, and EAP-GTC. (EAP-MD5 is not supported on VSCs that have WEP with dynamic keys enabled.)

CAUTION: To safeguard the integrity of RADIUS traffic it is important that you protect communications between the controller and the RADIUS server. The controller lets you use PPTP or IPSec to create a secure tunnel to the RADIUS server. For complete instructions on how to accomplish this, see ["Securing wireless client sessions with VPNs" \(page 507\)](#).

NOTE: If you change a RADIUS profile to connect to a different server while users are active, all RADIUS traffic for active user sessions is immediately sent to the new server.

Configuration procedure

1. Select **Controller >> Authentication > RADIUS profiles**. The RADIUS profiles page opens.



Name	Primary server	Secondary server	NAS ID

Add New Profile...

2. Select **Add New Profile**. The Add/Edit RADIUS Profile page opens.

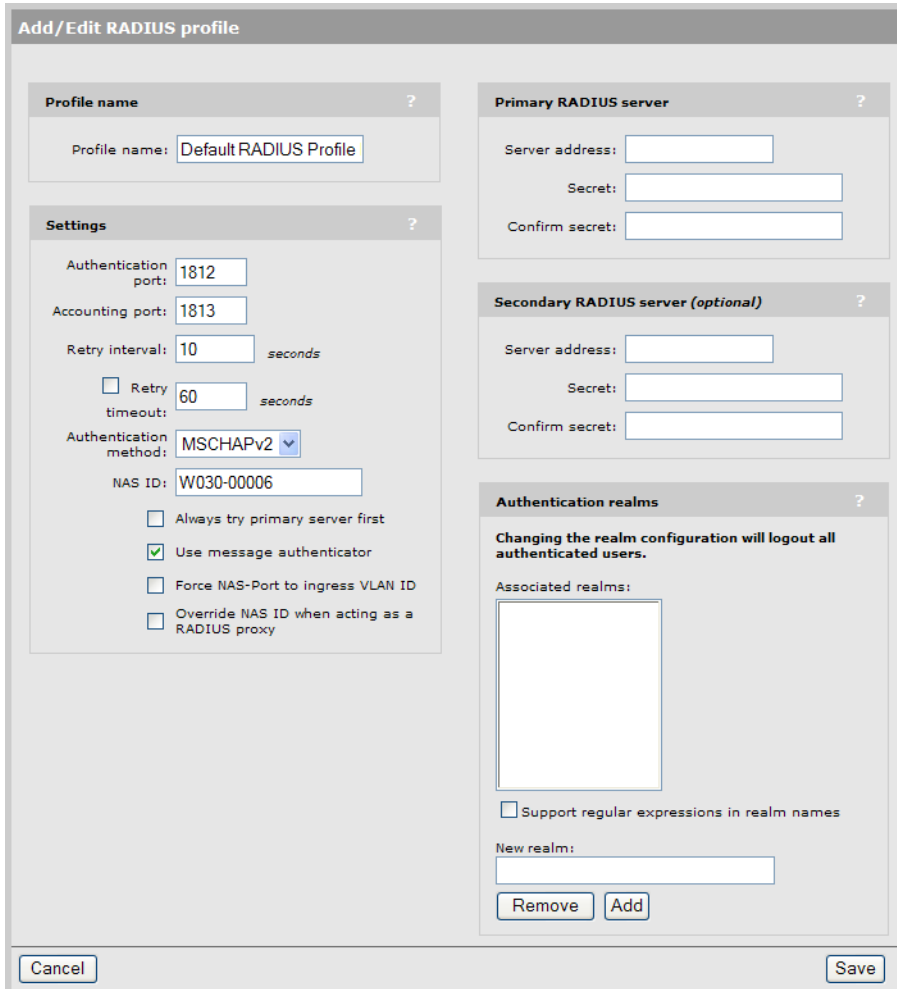

Add/Edit RADIUS profile

Profile name ?
Profile name:

Settings ?

Authentication port:
Accounting port:
Retry interval: seconds
 Retry timeout: seconds
Authentication method:
NAS ID:
 Always try primary server first
 Use message authenticator
 Force NAS-Port to ingress VLAN ID
 Override NAS ID when acting as a RADIUS proxy

Primary RADIUS server ?

Server address:
Secret:
Confirm secret:

Secondary RADIUS server (optional) ?

Server address:
Secret:
Confirm secret:

Authentication realms ?

Changing the realm configuration will logout all authenticated users.

Associated realms:

Support regular expressions in realm names

New realm:

3. Configure the profile settings as described in the following section.
4. Select **Save**.

Configuration parameters

Profile name

Specify a name to identify the profile.

Settings

Authentication port:

Specify a port on the RADIUS server to use for authentication. By default RADIUS servers use port 1812.

Accounting port

Specify a port on the RADIUS server to use for accounting. By default RADIUS servers use port 1813.

Retry interval

Specify the number of seconds that the controller waits before access and accounting requests time out. If the controller does not receive a reply within this interval, the controller switches between the primary and secondary RADIUS servers, if a secondary server is defined. A reply that is received after the retry interval expires is ignored.

Retry interval applies to access and accounting requests that are generated by the following:

- Manager or operator access to the management tool
- User authentication by way of HTML
- MAC-based authentication of devices
- Authentication of the controller
- Authentication of the controlled AP

You can determine the maximum number of retries as follows:

- HTML-based logins: Calculate the number of retries by taking the setting for the HTML-based logins **Authentication Timeout** parameter and dividing it by the value of this parameter. Default settings result in 4 retries (40 / 10).
- MAC-based and controller authentication: Number of retries is infinite.
- 802.1X authentication: Retries are controlled by the 802.1X client software.

Authentication method

Select the default authentication method that the controller uses when exchanging authentication packets with the RADIUS server defined for this profile. For 802.1X users, the authentication method is always determined by the 802.1X client software and is not controlled by this setting. If traffic between the controller and the RADIUS server is not protected by a VPN, HP recommends that you use either EAP-MD5 or MSCHAP V2 (if supported by your RADIUS server). PAP and MSCHAP V1 are less secure protocols. (EAP-MD5 is not supported on VSCs that have WEP with dynamic keys enabled.)

NAS ID

Specify the identifier for the network access server that you want to use for the controller. By default the serial number of the controller is used. The controller includes the NAS-ID attribute in all packets that it sends to the RADIUS server.

Always try primary server first

Enable this option if you want to force the controller to contact the primary server first.

Otherwise, the controller sends the first RADIUS access request to the last known RADIUS server that replied to any previous RADIUS access request. If the request times out, the next request is sent to the other RADIUS server if defined.

For example, assume that the primary RADIUS server was not reachable and that the secondary server responded to the last RADIUS access request. When a new authentication request is received, the controller sends the first RADIUS access request to the secondary RADIUS server.

If the secondary RADIUS server does not reply, the controller retransmits the RADIUS access request to the primary RADIUS server. When two servers are configured, the controller always alternates between the two.

Use message authenticator

When enabled, causes the RADIUS Message-Authenticator attribute to be included in all RADIUS access requests sent by the AP.

NOTE: This option has no effect on IEEE802dot1x authentication requests. These requests always include the RADIUS Message-Authenticator attribute.

Force NAS-Port to ingress VLAN ID:

When enabled, sets the RADIUS NAS-Port attribute content to the ingress VLAN ID for the VSC profile the user is connected to. If no ingress VLAN is defined, NAS-Port is set to 0.

The value of the NAS-Port in other locations, such as in placeholders or the system log, is not changed by enabling this option.

Override NAS ID when acting as a RADIUS proxy

This option applies only when this profile is used with VSCs that do not provide access control.

When this option is enabled, the controller replaces the value of the NAS ID inside RADIUS Requests it receives from APs with the value configured for NAS ID.

When this option is disabled, the controller replaces does not change the NAS ID inside RADIUS Requests it receives from APs. The requests are forwarded to their final destination unmodified.

Primary/Secondary RADIUS server

Server address

Specify the IP address or fully-qualified domain name of the RADIUS server.

Secret/Confirm secret

Specify the password for the controller to use to communicate with the RADIUS server. The shared secret is used to authenticate all packets exchanged with the server, proving that the packets originate from a valid/trusted source.

Authentication realms

When authentication realms are enabled for a profile, selection of the RADIUS server to use for authentication is based on the realm name, rather than the RADIUS profile name configured. This applies to any VSC authentication setting that uses the profile.

- Realm names are extracted from user names as follows: if the username is `person1@mydomain.com` then `mydomain.com` is the realm. The authentication request is sent to the RADIUS profile with the realm name `mydomain.com`. The username sent for authentication is still the complete `person1@mydomain.com`.
- For added flexibility, regular expressions can be used in realm names, enabling a single realm name to match many users. For example, if a realm name is defined with the regular expression `^per.*` then all usernames beginning with **per** followed by any number of characters will match. The following usernames would all match:

`per123.biz`

`per321.lan`

`per1`

Important

- Realms names are not case-sensitive and can be a maximum of 64 characters long.
- You can define a maximum of 200 realms across all RADIUS profiles. There is no limit to the number of realms that you can define for each RADIUS profile.
- Each RADIUS profile can be associated with one or more realms. However, a realm cannot be associated with more than one profile.
- A realm overrides the authentication RADIUS server only. The server used for accounting is not affected.
- When realm configuration is changed in any way, all active user sessions are terminated.

Support for regular expressions in realm names

Standard regular expressions can be used in realm names. For example:

Expression	Matches
mycompany[1-3].com	mycompany1.com mycompany2.com mycompany3.com
.*mycompany.com	Matches mycompany.com with any number of characters in front of it. For example: headoffice.mycompany.com or server-mycompany.com .
.*\..mycompany.com	Matches .mycompany.com with any number of characters in front of it. For example: headoffice.mycompany.com or server.mycompany.com , but not server-mycompany.com .

Authenticating manager logins using a third-party RADIUS server

Using a RADIUS server enables you to have multiple manager accounts, each with a unique login name and password. Identify manager accounts using the vendor specific attribute **web-administrative-role**. Valid values for this attribute are **Manager** and **Operator**. For attribute information, see [“Administrator attributes” \(page 457\)](#). To use a RADIUS server, you must define a RADIUS profile on the **Controller >> Authentication > RADIUS profiles** page.

NOTE: Login credentials for managers can be verified using local account settings and/or an third-party RADIUS sever. If both options are enabled, the RADIUS server is always checked first.

Configure RADIUS authentication as follows:

1. Define an account for the administrator on the RADIUS server. See [“Administrator attributes” \(page 457\)](#).
2. On the controller, create a RADIUS profile that will connect the controller to the RADIUS server. See [“Configuring a RADIUS server profile” \(page 364\)](#).
3. Select **Controller >> Management > Management tool**.
4. Under **Administrator authentication**, set **Authenticate via** to the RADIUS profile you created. In this example, the profile is called **RAD1**.

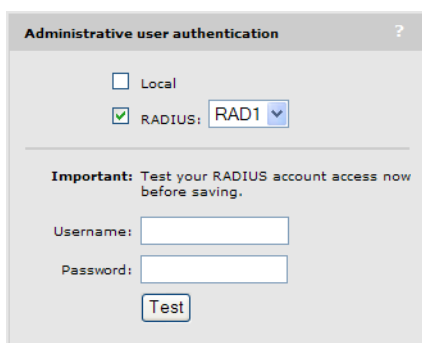

Administrative user authentication ?

Local

RADIUS: RAD1

Important: Test your RADIUS account access now before saving.

Username:

Password:

Test

5. Test the RADIUS account to make sure it is working before you save your changes. Specify the appropriate username and password and select **Test**.
(As a backup measure you can choose to enable **Local**. This will allow you to log in using the local account if the connection to the RADIUS server is unavailable.)

Using an Active Directory server

Active Directory is the Windows service that is used by many organizations for user authentication. The controller can communicate with an Active Directory server to authenticate user login credentials and retrieve configurations settings (attributes) that are applied to a users session.

An active directory server can be used to support the following authentication types:

Service	For details, see ...
802.1X (VSC)	"802.1X authentication" (page 334)
MAC-based (Global)	"MAC-based authentication" (page 132)
MAC-based (VSC)	"MAC-based authentication" (page 132)
HTML-based	"HTML-based authentication" (page 347)
VPN-based	"VPN-based authentication" (page 349)

NOTE: The controller cannot join an Active Directory domain if the domain uses multiple DNS servers balanced by the *Round Robin* feature.

Supported protocols

- EAP-PEAP
- EAP-TLS
- EAP-TTLS: Requires that client stations are configured to use MS-CHAP or MS-CHAP-V2.

Active Directory configuration

To configure active directory support, select **Controller >> Authentication > Active Directory**.

NOTE: It is important that the system time on the controller is accurate when an Active Directory server is being used. To set the time select **Controller >> Management > System time**.

The screenshot shows the 'Active directory settings' window, divided into two main sections: 'General' and 'Join'.

General section:

- Device name: [Text input field]
- Domain NetBIOS name: [Text input field]
- Windows domain: [Text input field]
- Check Active Directory access with attribute
- Use Active Directory remote access permission
- Use LDAP attribute: [Text input field containing 'MsNPAAllowDialin']

Join section:

- Username: [Text input field]
- Password: [Text input field]
- [Join Realm Now button]
- Status: [Text area]

[Save button]

Active Directory group attributes section:

Active Directory group name	Access controlled	Priority
Default AC Active Directory group	Yes	
Default non AC Active Directory group	No	

[Add New Group... button] [Save Priority Settings button]

Active directory settings

General

Device name

Specify a name that identifies the controller to Active Directory. The controller uses this name to connect to the active directory server, just like any standard active directory client does.

Domain NetBIOS name

Specify the NetBIOS domain to which the controller belongs. Generally, the NetBIOS domain name is the first segment of the Windows domain name. For example: if Windows domain is `rd.mycompany.com`, then NetBIOS would be `rd`.

Windows domain

Specify the Windows domain to which the controller belongs. The controller must be part of a Windows domain (`mydomain.com`, for example) to authenticate users that belong to that domain.

Check Active Directory access with attribute

Enable this option to have the controller only accept users with a specific setting in their account.

- **Use Active Directory remote access permission:** Use the standard attribute defined in Active Directory for remote access (`MsNPAllowDlalin`). If this attribute is set, then the user can be authenticated via Active Directory.
- **Use LDAP attribute:** For non-standard implementation of Active Directory, set this according to the equivalent setting on the Active Directory server.

Join

Before the controller can process user authentication using Active Directory, you must join the controller with the Active Directory server. Fill in the required parameters and select **Join Realm Now**. This is usually a one-time event. (Note: The controller cannot be used with an Active Directory domain that is configured to support multiple DNS servers balanced by the *Round Robin* feature.)

Username

Username the controller will use to join Active Directory.

Password

Password the controller will use to join Active Directory.

NOTE: For security reasons, **Username** and **Password** are not stored on the controller.

Join Realm Now

Select to join the realm immediately.

Status

Shows the status of the join operation as follows:

- **Unknown:** System is processing, no status to report. Refresh the page to update the status.
- **DNS unavailable:** DNS not working, cannot access Active Directory.
- **Missing Config:** No configuration, so join cannot proceed.
- **Never Joined:** Administrator never selected **Join Realm Now**.
- **Not joined:** Not joined: May be joined with the domain, but the join is not confirmed yet. Status will change to **Joined** once confirmed. If the **Not Joined** status persists, check connectivity between the controller and Active Directory or re-join.
- **Joined:** Active Directory reports that controller successfully joined.

Active Directory groups attributes

Displays all Active Directory groups that are defined on the controller. These groups are used to assign attributes to a user once they have been authenticated by Active Directory.

NOTE: Group names on the controller must be identical to existing Active Directory security group names configured on the Active Directory Server.

Once a user is authenticated by Active Directory, the controller retrieves the names of all the active directory groups of which the user is a member.

- If the user is a member of only one Active Directory group, and that group name appears in the list, the controller applies the attributes from that group.
- If the user is a member of more than one Active Directory group, the controller applies the attributes from the matching group name with the highest priority (highest in the list).
- If no match is found, the attributes defined for one of the default groups are applied as follows:
 - If the VSC the user logged in on is access-controlled then the **Default AC Active Directory group** is used.
 - If the VSC the user logged in on is not access-controlled then the **Default non AC Active Directory group** is used.

NOTE: The default groups are disabled by default. You need to enable them before they can be used.

Add New Group

Select to add a new group. See “Configuring an Active Directory group” (page 371).

Save Priority Settings

After using the up/down arrows to change the priority of groups, save your changes by selecting this button.

Configuring an Active Directory group

An active directory group defines the characteristics of a user session. To make group configuration easy, account profiles (“Account profiles” (page 351)) can be applied to set group attributes.

The screenshot shows the 'Add/Edit Active Directory group attributes' dialog box. It is divided into several sections:

- General:** Contains a 'Group name' text box with 'Default group name' entered. Below it are two checked checkboxes: 'Active' and 'Access-controlled group'.
- VSC usage:** Includes a checkbox for 'VSC usage'. Below it are two lists: 'Available VSCs' (empty) and 'Restrict this account to these VSCs' (containing 'HP').
- Account profiles:** Includes a checkbox for 'Account profiles'. Below it are two lists: 'Available profiles' (empty) and 'Set account attributes using these profiles' (empty).
- Effective attributes:** Contains a text area with the text: 'The default AC profile is always taken into account.' and 'No attributes defined'.

At the bottom of the dialog are 'Cancel' and 'Save' buttons.

Configuration parameters

General

Group name

Specify a name to identify the group. This name must match an existing Active Directory Security Group configured on the Active Directory Server.

Active

Enable this option to activate the group. The group cannot be used until it is active.

Access-controlled group

Determines whether the group is access-controlled or not.

- Access-controlled groups can only be used to log in on VSCs that are access-controlled.
- Non access-controlled groups can only be used to log in on VSCs that are not access-controlled.

VSC usage

Enable this option to restrict this group to one or more VSCs. If the selected VSCs are not defined on an AP, users will not be able to log in on this account.

The **Available VSCs** list shows all defined VSCs that you can select from.

To move VSCs between the two lists:

- Double-click the profile you want to move.
- Or, select the profile you want to move and then select the left or right arrow.

Account profiles

Enable this option to set the attributes of this group using one or more account profiles.

The **Available profiles** list shows all defined profiles that you can select from. To add a new profile, open the **Controller >> Users > Account profiles** page.

To move profiles between the two lists, double-click the profile you want to move, or select the profile you want to move and then select the left or right arrow.

Effective attributes

This list shows all attributes that are active for this Active Directory group. Each time you add an account profile for use by this group, all attributes configured in the profile are added to the **Effective attributes** list.

NOTE: Each profile that is applied to a group must have a unique set of attributes. The same attribute cannot be present in two different account profiles.

About the Default AC profile

The **Default AC profile** is always present and is always applied to all Active Directory groups. You can use this profile to add additional attributes that are not configurable in an account profile. Instead, these attributes are configured on the **Controller >> Public access > Attributes** page. Once added there, they will automatically appear in the **Effective attributes** list.

The following attributes can be added using this method:

Attribute	For information, see
default-user-use-access-list	"Default user URLs" (page 475).
default-user-goodbye-url	"Default user URLs" (page 475).
default-user-one-to-one-nat	"Default user one-to-one NAT" (page 474).

Attribute	For information, see
default-user-idle-timeout	"Default user idle timeout" (page 473).
default-user-session-timeout	"Default user session timeout" (page 474).
default-user-acct-interim-update	"Default user interim accounting update interval" (page 472).
default-user-max-output-packets	"Default user quotas" (page 473).
default-user-max-input-packets	"Default user quotas" (page 473).
default-user-max-total-packets	"Default user quotas" (page 473).
default-user-max-output-octets	"Default user quotas" (page 473).
default-user-max-input-octets	"Default user quotas" (page 473).
default-user-max-total-octets	"Default user quotas" (page 473).
default-user-max-input-rate	"Default user data rates" (page 474).
default-user-max-output-rate	"Default user bandwidth level" (page 473).
default-user-use-public-ip-subnet	"Default user public IP address" (page 475).

Configuring a VSC to use Active Directory

Any VSC feature that can be configured to support remote authentication can be configured to use Active Directory. For example, with HTML logins.

The screenshot shows the configuration window for "HTML-based user logins". It is divided into two sections: "Authentication" and "General".

Authentication Section:

- Local
- Remote
 - Active directory
 - RADIUS: RAD_1 (dropdown menu)
 - Request RADIUS CUI
- Authentication timeout: 40 (text input)

General Section:

- RADIUS accounting: RAD_1 (dropdown menu)

18 Security

Firewall

To safeguard your network from intruders, the controller features a customizable stateful firewall. The firewall operates on the traffic streaming through the Internet port. It can be used to control both incoming and outgoing data.

A number of predefined firewall rules let you achieve the security level you need without going to the trouble of designing your own rules. However, you can create a completely custom set of firewall rules to suit your particular networking requirements, if necessary.

If the controller is connected to a wired LAN, the firewall protects the wired LAN as well.

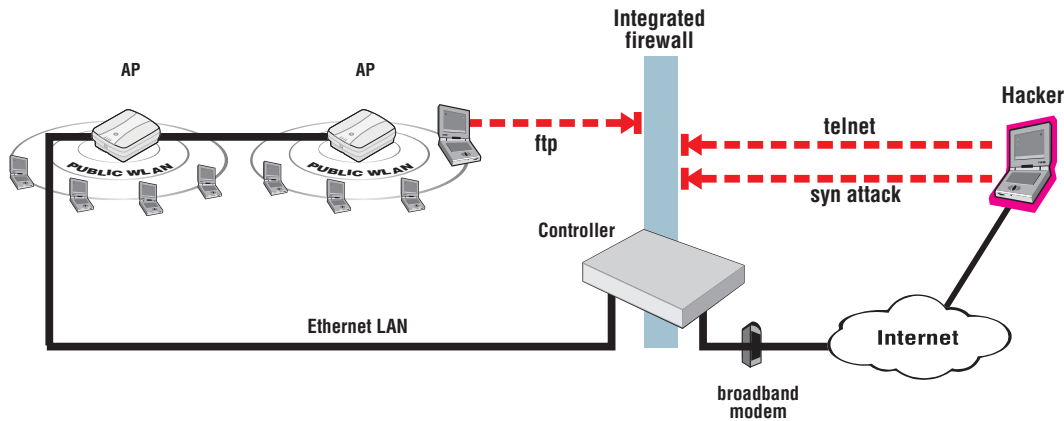

Firewall presets

The easiest way to use the firewall is to use one of the preset settings. Two levels of security are provided:

- **High:** Permits all outgoing traffic, except NetBIOS (TCP and UDP). Blocks all externally initiated connections.
- **Low:** Permits all incoming and outgoing traffic, except for NetBIOS traffic. Use this option if you require active FTP sessions.

The following tables indicate how some common applications are affected by the preset firewall settings.

Outgoing traffic	Firewall setting	
	Low	High
Application		
FTP (passive mode)	Passed	
FTP (active mode)	Passed	
Web (HTTP, HTTPS)	Passed	
SNMP	Passed	
Telnet	Passed	
Windows networking	Blocked	
ping	Passed	
PPTP from client station to remote server	Passed	
NetMeeting (make call)	Passed	

Outgoing traffic	Firewall setting	
Application	Low	High
IPSec pass-through	Passed	
NetBIOS	Blocked	

Incoming traffic	Firewall setting	
Application	Low	High
FTP (passive mode)	Passed	Blocked
FTP (active mode)	Passed	Blocked
Web (HTTPS)	Passed	Blocked
Web (HTTP)	Passed	Blocked
Telnet	Passed	Blocked
Windows networking	Passed	Blocked
PPTP from remote client to a server on the local network	Passed	Blocked
ping client on local network	Passed	Blocked
IPSec pass-through	Passed	Blocked
NetBIOS	Passed	Blocked
NetMeeting (receive call)	Passed	Blocked

Firewall configuration

To configure a firewall, select **Controller >> Security > Firewall**. The **Firewall configuration** page opens.

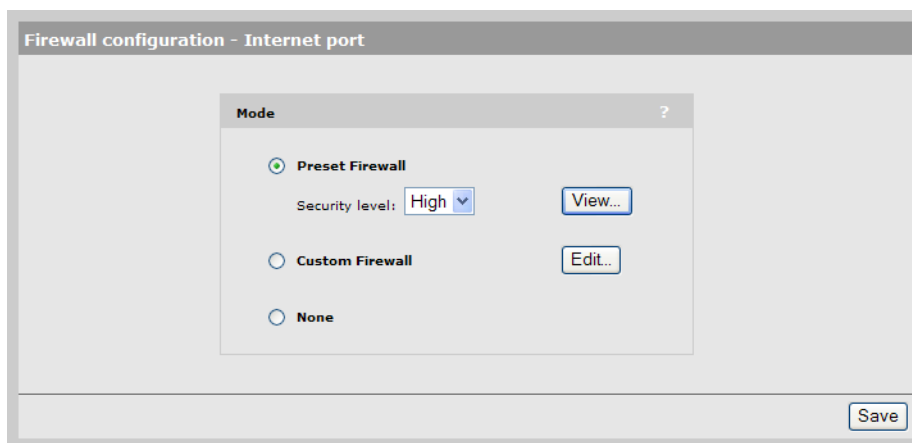

- Select **Preset Firewall** to use a preconfigured firewall setting of **High** or **Low**. Select **View** to see the firewall rules for the selected setting.
- Select **Custom Firewall** if you have specific security requirements. This setting enables you to target specific protocols or ports.

Customizing the firewall

To customize the firewall, you define one or more rules. A rule lets you target a specific type of data traffic. If the controller finds data traffic that matches the rule, the rule is triggered, and the traffic is rejected or accepted by the firewall.

To add a rule, select **Custom Firewall** on page **Controller >> Security > Firewall**, select **Edit**, and then select **Add New Rule**.

The screenshot shows a configuration window titled "Custom firewall configuration - Add rule". It is divided into three main sections:

- IP addresses & direction:** Contains input fields for Source (set to "ANY"), Source mask, Destination (set to "ANY"), Destination mask, Direction (set to "Input"), and Action (set to "Accept").
- Services:** Contains a "Presets" dropdown menu currently set to "All".
- Stateful matching:** Contains four checkboxes: "New packet", "Established packet", "Related packet", and "Invalid packet", all of which are currently unchecked.

At the bottom of the window, there are "Cancel" and "Add" buttons.

Rules operate on IP datagrams (sometimes called *packets*). Datagrams are the individual packages of data that travel on an IP network. Each datagram contains addressing and control information along with the data it is transporting. The firewall analyses the addressing and control information to apply the rules you define.

The controller applies the firewall rules in the order that they appear in the list. An intelligent mechanism automatically adds the new rules to the list based on their scope. Rules that target a large amount of data are added at the bottom. Rules that target specific datagram attributes are added at the top.

Managing certificates

Digital certificates are electronic documents that are used to validate the end parties or entities involved in data transfer. These certificates are normally associated with X.509 public key certificates and are used to bind a public key to a recognized party for a specific time period.

The certificate stores provide a repository for managing all certificates (except for those used by IPSec and NOC authentication). To view the certificate stores, select **Controller >> Security > Certificate stores**.

Trusted CA certificate store						
ID	Issued to	Current usage	Start date	Expiration date	CRL	Delete
1	SOAP API Certificate Authority	SOAP Server	2005-04-06	2025-04-01	No	
2	Dummy Authority	RADIUS EAP	2007-04-12	2017-04-09	No	
3	Entrust.net Secure Server Certification Authority	Authorize.Net	1999-05-25	2019-05-25	No	
4	Management Console Dummy Authority	HP Management console	2010-05-19	2020-05-16	No	

PKCS #7 file or X.509 certificate:

Certificate and private key store						
ID	Issued to	Issued by	Current usage	Start date	Expiration date	Delete
1	wireless.hp.internal	wireless.hp.internal	Web Management Tool, SOAP Server, HTML authentication, Billing records logging system	2010-11-03	2038-10-27	
2	Dummy Server Certificate	Dummy Authority	RADIUS EAP	2007-04-12	2017-04-09	
3	Management Console Default client certificate	Management Console Dummy Authority	HP Management console	2010-05-19	2020-05-16	

PKCS #12 file: PKCS #12 password:

Trusted CA certificate store

This list displays all root CA (certificate authority) certificates installed on the controller. The controller uses these CA certificates to validate the certificates supplied by peers during authentication. Multiple CA certificates can be installed to support validation of clients with certificates issued by different CAs.

The controller uses these certificates to validate certificates supplied by:

- Managers or operators accessing the controller's management tool.
- HTML users accessing the public access interface.
- SOAP clients communicating with the controller's SOAP server.
- RADIUS EAP

The following information is presented for each certificate in the list:

- **Status light:** Indicates the certificate state.
 - **Green:** Certificate is valid.
 - **Yellow:** Certificate will expire soon.
 - **Red:** Certificate has expired.
- **ID:** A sequentially assigned number to help identify certificates with the same common name.
- **Issued to:** Name of the certificate holder. Select the name to view the contents of the certificate.
- **Issued by:** Name of the CA that issued the certificate.
- **Current usage:** Lists the services that are currently using this certificate.
- **Start/Expiration date:** Indicates the period during which the certificate is valid.
- **CRL:** Indicates if a certificate revocation list is bound to the certificate. An X.509 certificate revocation list is a document produced by a certificate authority (CA) that provides a list of serial numbers of certificate that have been signed by the CA but that should be rejected.
- **Delete:** Select to remove the certificate from the certificate store.

Installing a new CA certificate

1. Specify the name of the certificate file or select **Browse** to choose from a list. CA certificates must be in X.509 or PKCS #7 format.
2. Select **Install** to install a new CA certificate.

CA certificate import formats

The import mechanism supports importing the ASN.1 DER encoded X.509 certificate directly or as part of two other formats:

- PKCS #7 (widely used by Microsoft products)
- PEM, defined by OpenSSL (popular in the Unix world)
- The CRL can be imported as an ASN.1 DER encoded X.509 certificate revocation list directly or as part of a PEM file.

Content and file format	Items carried in the file	Description
ASN.1 DER encoded X.509 certificate	One X.509 certificate	This is the most basic format supported, the certificate without any envelope.
X.509 certificate in PKCS #7 file	One X.509 certificate	Popular format with Microsoft products.
X.509 certificate in PEM file	One or more X.509 certificates	Popular format in the Unix world. X.509 DER certificate is base64 encoded and placed between "-----BEGIN CERTIFICATE-----" and "-----END CERTIFICATE-----" lines. Multiple certificates can be repeated in the same file.
ASN.1 DER encoded X.509 CRL	One X.509 CRL	Most basic format supported for CRL.
X.509 CRL in PEM file	One X.509 CRL	Same format as X.509 certificate in PEM format, except that the lines contain BEGIN CRL and END CRL.

Default CA certificates

The following certificates are installed by default:

- **SOAP API Certificate Authority:** Before allowing a SOAP client to connect, the controller checks the certificate supplied by a SOAP client to ensure that it is issued by a trusted certificate authority (CA).
- **Dummy Authority:** Used by the internal RADIUS server. You should replace this with your own CA certificate.
- **Entrust.net Secure Server Certification Authority:** This is the `Authorize.Net` CA certificate. It is used to support credit card payments via `Authorize.Net`.
- **Management Console Dummy Authority:** Used when the management tool communicates with HP PCM/PMM software.

NOTE: For security reasons, you should replace the default certificates with your own.

Certificate and private key store

This list displays all certificates installed on the controller. The controller uses these certificates and private keys to authenticate itself to peers.

Items provided in this list are as follows:

Status indicator

Indicates the certificate state.

- **Green:** Certificate is valid.
- **Yellow:** Certificate will expire soon.
- **Red:** Certificate has expired.

ID

A sequentially assigned number to help identify certificates with the same common name.

Issued to

Name of the certificate holder. Select the name to view the contents of the certificate.

Issued by

Name of the CA that issued the certificate.

Current usage

Lists the services that are currently using this certificate.

Start/Expiration date

Indicates the period during which the certificate is valid.

Delete

Select to remove the certificate from the certificate store.

Installing a new private key/public key certificate chain pair

NOTE: RADIUS EAP certificates must have the X.509 extensions. Information about this is available in the Microsoft knowledgebase at: <http://support.microsoft.com/kb/814394/en-us>

The certificate you install must:

- Be in PKCS #12 format.
- Contain a private key (a password controls access to the private key).
- Not have a name that is an IP address. The name should be a domain name containing at least one dot. If you try to add a certificate with an invalid name, the default certificate is restored.

The common name in the certificate is automatically assigned as the domain name of the controller.

1. Specify the name of the certificate file or select **Browse** to choose one from a list. Certificates must be in PKCS #7 format.
2. Specify the **PKCS #12 password**.
3. Select **Install** to install the certificate.

Default installed private key/public key certificate chains

The following private key/public key certificate chains are installed by default:

- **wireless.hp.internal:** Default certificate used by the management tool, SOAP server, and HTML-based authentication.
- **Dummy Server Certificate:** Used by the internal RADIUS server. This certificate is present only to allow EAP-PEAP to work if the client chooses not to verify the server's certificate. You should replace this with your own certificate for maximum security.
- **Management Console Default client certificate:** This certificate is used to identify the management tool when it communicates with HP PCM/PMM software.

NOTE: When a Web browser connects to the controller using SSL/TLS, the controller sends only its own X.509 certificate to the browser. This means that if the certificate has been signed by an intermediate certificate authority, and if the Web browser only knows about the root certificate authority that signed the public key certificate of the intermediate certificate authority, the Web browser does not get the whole certificate chain it needs to validate the identity of the controller. Consequently, the Web browser issues security warnings. To avoid this problem, make sure that you install the entire certificate chain when you install a new certificate on the controller.

NOTE: An SNMP notification can be sent to let you know when the controller SSL certificate is about to expire. To enable this notification, select **Controller >> Management > SNMP** and enable the **Notifications** option. Then select **Configure Notifications**, enable **Event notifications**, and then select the event **Maintenance certificate about to expire** under **System**. See [“Configuring SNMP notifications for events and alarms” \(page 215\)](#).

Certificate usage

To see the services that are associated with each certificate, select **Controller >> Security > Certificate usage**. With the factory default certificates installed, the page will look like this:

Service	Authenticate to peer using	Number of associated CAs
Web Management Tool	1 - wireless.hp.internal	0
SOAP Server	1 - wireless.hp.internal	1
HTML authentication	1 - wireless.hp.internal	0
RADIUS EAP	2 - Dummy Server Certificate	1
Authorize.Net	<none>	1
Billing records logging system	1 - wireless.hp.internal	0
HP Management console	3 - Management Console Default cl	1

Service

Name of the service that is using the certificate. To view detailed information on the certificate select the service name.

Authenticate to peer using

Name of the certificate and private key. The controller is able to prove that it has the private key corresponding to the public key in the certificate. This is what establishes the controller as a legitimate user of the certificate.

Number of associated CAs

Number of CA certificates used by the service.

Changing the certificate assigned to a service.

Select the service name to open the Certificate details page. For example, if you select **Web Management Tool**, you will see:

The screenshot shows the 'Services PKI management' page for the 'Web Management Tool' service. It features a 'Service' field with the value 'Web Management Tool' and an 'Authentication to the peer' section with a 'Local certificate' dropdown menu set to '1 - wireless.hp.internal'. A 'Peer authentication' section below indicates that peer authentication is not possible for this service. A 'Save' button is located at the bottom right of the form.

Under **Authentication to the peer**, select a new **Local certificate** and then select **Save**.

About certificate warnings

Access to the management tool and the public access interface Login page occur through a secure connection (SSL/TLS). An X.509 certificate is used to validate this connection. The default X.509 certificate installed on the controller for SSL/TLS for access to the management tool and the public access interface is not registered with a certificate authority. It is a self-signed certificate that is attached to the default IP address (192.168.1.1) for the controller LAN port. As a result, certificate warnings will appear at login until you install a valid, trusted certificate on the controller.

The host name in the currently installed SSL certificate is automatically assigned as the domain name of the controller. You do not have to add this name to your DNS server for it to be resolved. The controller intercepts all DNS requests it receives on the wireless or LAN ports. It resolves any request that matches the certificate host name by returning the IP address assigned to the wireless port. All other DNS requests are forwarded to the appropriate DNS servers as configured on the **Network > DNS** page.

This means that once a valid, trusted certificate is installed on the controller, users will no longer see a certificate warning message when logging in.

IPSec certificates

IPSec certificates are managed on the lower portion of the **Controller >> VPN > IPSec** page.

The screenshot displays the 'IPSec certificates' management page, which is organized into six panels arranged in a 3x2 grid. Each panel has a title bar with a question mark icon for help.

- IPSec -- Trusted CA certificates:** Features a 'Certificate file:' input field with a 'Browse...' button. Below the field, it specifies 'X.509 or PKCS #7 format' and includes an 'Install' button.
- IPSec -- Manage CA certificates:** Includes a 'Certificates:' dropdown menu and 'Remove' and 'View...' buttons.
- IPSec -- Local certificate store:** Contains a 'Certificate Request Wizard' button. Below it, there is a 'Certificate file:' field with a 'Browse...' button, a 'Password:' field, and an 'Install' button. The format is noted as 'PKCS #12 format'.
- IPSec -- Manage local certificate:** Shows a 'Certificate:' dropdown menu and 'Remove' and 'View...' buttons.
- IPSec -- X.509 certificate revocation list:** Has a 'CRL file:' field with a 'Browse...' button and an 'Install' button. Below this, there are fields for 'LDAP server:' and 'Port:', followed by a 'Save' button.
- IPSec -- Manage certificate revocation list:** Features a 'CRLs:' dropdown menu and 'Remove' and 'View...' buttons.

IPSec Trusted CA certificates

The controller uses the CA certificates to validate the certificates supplied by peers during the authentication process. Multiple CA certificates can be installed to support validation of peers with certificates issued by different CAs.

- **Certificate file:** Specify the name of the certificate file or select **Browse** to choose from a list. CA certificates must be in X.509 or PKCS #7 format.
- **Install:** Select to install the specified certificate.

IPSec Manage CA certificates

Use this box to manage the root CA certificate.

- **Certificate:** Select from a list of installed certificates.
- **Remove:** Delete the item shown under **Certificate**.
- **View:** Open the item shown under **Certificate** for viewing.

IPSec Local certificate store

This is the certificate that the controller uses to identify itself to IPSec peers.

NOTE: If the local certificate includes a CA certificate, both certificates are installed.

- **Certificate Request Wizard:** Helps you to generate a certificate request that can be used to obtain a signed certificate from a certificate authority. Once you obtain the certificate, you can use the **Certificate Request Wizard** to install it on the controller.
- **Certificate file:** Specify the name of the certificate file or select **Browse** to choose from a list.
- **Password:** Specify the certificate password.
- **Install:** Select to install the certificate.

IPSec Manage local certificate

Use this box to manage the local certificate.

- **Certificate:** Shows the common name of the installed certificate.
- **Remove:** Delete the item shown under **Certificate**.
- **View:** Open the item shown under **Certificate** for viewing.

IPSec X.509 certificate revocation list

Use this box to update the certificate revocation list (CRL) that is issued by the certificate authority.

The controller uses the CRL to determine if the certificates provided by clients during the authentication process have been revoked. The controller will not establish a security association with a client that submits a revoked certificate.

The controller can obtain a CRL in two ways:

- You can manually install it.
- The controller can automatically install a CRL based on information contained in a client certificate. This occurs only if a CRL is not installed, or if the installed CRL is expired.
- **CRL file:** Specify the name of the CRL file or select **Browse** to choose from a list.
- **Install:** Select to install the specified CRL.
- **LDAP server:** A client certificate may contain a list of locations where the CRL can automatically be retrieved. This location may be specified as an HTTP URL, FTP URL, LDAP URL, or LDAP directory. If the LDAP URL or directory is incomplete, the controller uses the location you specify to resolve the request. Incomplete HTTP or FTP URLs fail.
- **Port:** Port on the LDAP server. Default is 389.

IPSec Manage certificate revocation list

Use this box to manage the CRL.

- **CRLs:** Shows a list of installed certificate revocation lists.
- **Remove:** Deletes the item shown under **CRLs**.
- **View:** Opens the item shown under **CRLs** for viewing.

Certificate expiration alerts

The following warnings are generated when a certificate is about to expire:

- The status light for the certificate turns yellow. See [“Trusted CA certificate store” \(page 377\)](#).
- A message appears on the management tool home page. For example:
- The following syslog message is sent every 24 hours:
Warning: n certificate(s) is(are) about to expire. Please go to the Certificates page for more information.
Where n is the number of certificates that are about to expire.
- When logging into the CLI, a message similar to the syslog message above is displayed.

19 Local mesh

Key concepts

The local mesh feature enables you to create wireless links between two or more APs. These links provide a wireless bridge that interconnects the networks connected to the Ethernet port on each AP.

The local mesh feature replaces the need for Ethernet cabling between APs, making it easy to extend your network in hard-to-wire locations or in outdoor areas.

Key local mesh features include:

- **Automatic link establishment:** Nodes automatically establish wireless links to create a full-connected network. A dynamic network identifier (local mesh group ID) restricts connectivity to groups of nodes, enabling distinct groups to be created with nodes in the same physical area.
- **Provides fall-back operation to recover from node failure.** In a properly designed implementation, redundant paths can be provided. If a node fails, the mesh will automatically reconfigure itself to maintain connectivity.
- **Maintains network integrity when using DFS channels.** In accordance with the 802.11h standard, dynamic frequency selection (DFS) detects the presence of certain radar devices on a channel and automatically switches the network node to another channel if such signals are detected. 802.11h is intended to resolve interference issues with military radar systems and medical devices.

NOTE: Depending on the radio regulations of some countries, DFS channels are only available on the 802.11a/n bands, which are the preferred band for local mesh backhaul. If more than one node detects radar simultaneously and must switch channels, each node does not necessarily switch to the same channel, and the network might never reconverge. To avoid this problem, local mesh detects a change in channel and provides a means to reconnect on other channels by scanning on multiple channels. See [“Operating channel” \(page 386\)](#).

Simultaneous AP and local mesh support

APs can be configured to support both access point and local mesh functionality whether they have a single radio, or multiple radios.

Single radio APs

A single radio can be configured to simultaneously support wireless users and one or more local mesh links. Although this offers flexibility it does have the following limitations:

- The total available bandwidth on the radio is shared between all local mesh links and wireless users. This can result in reduced throughput if lots of traffic is being sent by both wireless users and the local mesh links. You can use the QoS feature to prioritize traffic.
- It limits you to using the same radio options for both wireless clients and local meshes.

Multiple radio APs

On APs with more than one radio, one radio can be dedicated to support wireless users and another to provide local mesh links. Each radio can be configured optimally according to its application.

Controlled APs

Controlled APs can be managed over local mesh links.

Using 802.11a/n for local mesh

HP recommends that 802.11a/n in the 5 GHz band be used for local mesh links whenever possible. This optimizes throughput and reduces the potential for interference because:

- Most Wi-Fi clients support 802.11b or b/g, therefore most APs are set to operate in the 2.4 GHz band. This frees the 5 GHz (802.11a/n) band for other applications such as local mesh.
- 802.11a/n channels in the 5 GHz band are non-overlapping.
- 802.11a/n provides increased data throughput, providing a *fat pipe* for traffic exchange.

The main limitations in using the 5 GHz band are:

- Since the same radio options must be used for both wireless clients and local mesh links, support for 802.11b/g clients is not possible on APs with a single radio.
- The 5 GHz band has a shorter reach when compared to the 2.4 GHz band. This could be a factor depending on the distance your links must span.

Local mesh terminology

The following table defines terms that are used in this guide when discussing the local mesh feature.

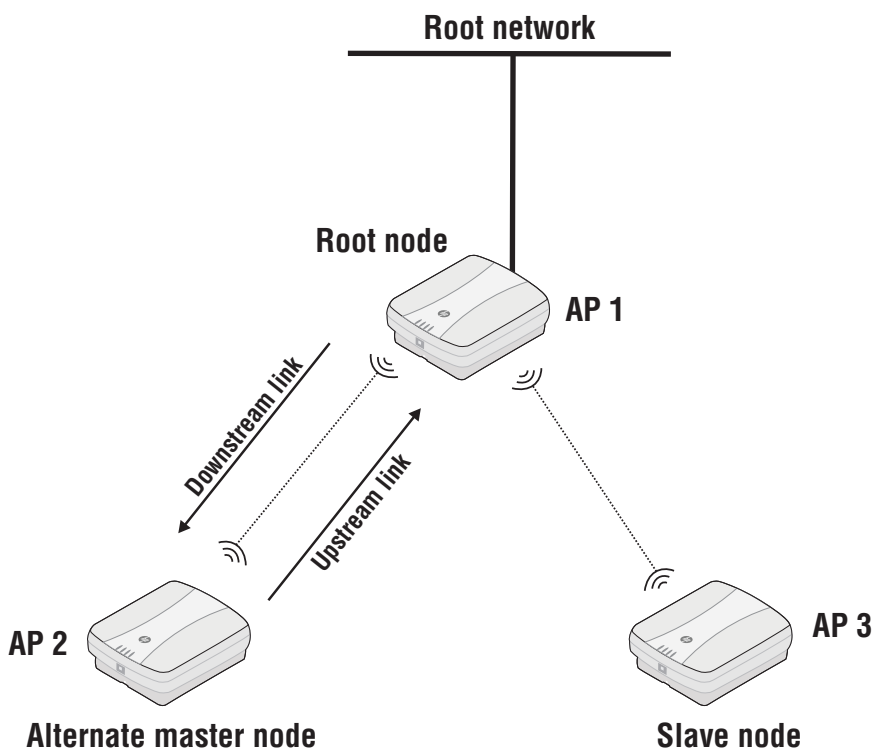

Term	Definition
Node	An AP that is configured to support local mesh connections.
Root node	The root node is configured in Master mode and provides access to the root network.
Alternate master node	A node that is configured in Alternate master mode which enables it to make upstream and downstream connections.
Slave node	A node that is configured in Slave mode which enables it to make upstream connections only.
Root network	Wired network to which the root node is connected. This is the network to which the local mesh provides access for all connected alternate master and slave nodes.
Mesh	A series of nodes that connect to form a network. Each mesh is identified by a unique mesh ID.

Term	Definition
Link	The wireless connection between two nodes.
Downstream link	A link that transports data away from the root network.
Upstream link	A link that transports data towards the root network.
Peer	Any two connected nodes are peers. In the diagram, AP 1 is the peer of both AP 2 and AP 3.

Local mesh operational modes

Three different roles can be assigned to a local mesh node: **Master**, **Alternate Master**, or **Slave**. Each role governs how upstream and downstream links are established by the node.

- **Master:** Root node that provides the upstream link to the ground network that the other nodes want to reach. The master never tries to connect to any other node. It waits for links from downstream alternate master or slave nodes.

NOTE: It is possible to have several masters for the same mesh ID connected to the ground network. This can be used to provide redundant paths to the ground network for downstream nodes.

- **Alternate Master:** First establishes an upstream link with a master or alternate master node. Next, operates as a master node waiting for links from downstream alternate master or slave nodes.
- **Slave:** Can only establish an upstream link with master or alternate master node. Slave nodes cannot establish downstream links with other nodes.

Node discovery

Discovery of another node to link with is limited to nodes with the same mesh ID. The link is established with the node that has the best score based on the following calculation:

Score = SNR - (Number of hops x SNR cost of each hop)

If a node loses its upstream link, it automatically discovers and connects to another available node.

NOTE: A master or alternate master must be seen with an SNR of 20 or higher before a slave will attempt to connect to it.

Operating channel

If a mesh operates on a dynamic frequency selection (DFS) channel, the master node selects the operating channel. If another node detects radar and switches channels, that node reports the channel switch to the master node, which initiates a channel switch for the nodes connected to it. This allows the local mesh to converge on a specific channel.

A node that uses a DFS channel and that loses connection with its master, scans channels to find a master on another channel, which can be a new master or the same master.

If the local mesh does not operate on a DFS channel, configure the radios in one of the following ways:

- Configure the radios on all nodes to use the same fixed channel.
- Configure the radios for automatic channel selection. In this case the master selects the least noisy channel. Slaves and alternate masters scan channels until they find the master, then tune to the master channel and link with the master.

Local mesh profiles

Each node supports up to six profiles plus one provisioning profile. When a profile is active, a node constantly scans and tries to establish links as defined by the profile.

The **local mesh provisioning profile** is used by the wireless link created on a provisioned AP to support discovery of the controller. Initially, this link operates in slave mode. If you configure this profile as an alternate master, then it can also be used to establish up to nine downstream links with alternate master or slave nodes. See [“Provisioning local mesh links” \(page 391\)](#) for more information.

Local mesh profiles are configurable at the controlled APs, group, or AP level. To view all profiles select **Controller > Controlled APs >> Configuration > Local mesh**. Or you can expand **Controlled APs** and select a group or specific AP. The following is an example of the profile list displayed when selecting **Controlled APs >> Configuration > Local mesh**.

Enabled	Name	Mode	Mesh ID	Security
N/A	Local mesh provisioning profile	Slave	N/A	N/A
No	Local mesh profile #1	Master	1	NONE
No	Local mesh profile #2	Master	1	NONE
No	Local mesh profile #3	Master	1	NONE
No	Local mesh profile #4	Master	1	NONE
No	Local mesh profile #5	Master	1	NONE
No	Local mesh profile #6	Master	1	NONE

Configuration guidelines

- In addition to the provisioning profile, you can configure a total of six local mesh profiles on each node.
- Each local mesh profile (on a master or alternate master) can be used to establish up to nine links with other nodes.
- The same security settings must be used on all nodes in the same mesh.
- Any node that reaches the controller through the local mesh and uses local mesh itself, must be provisioned prior to discovery.
- Daisy-chaining of nodes using local mesh links dramatically reduces throughput (which is typically divided by two for each hop) especially when one or more of the following are true:
 - Nodes provide both upstream and downstream links on the same radio.
 - Nodes share a radio with AP functionality.
 - IP traffic originating from a node can be sent on the link on which the controller was discovered.

Configuring a local mesh profile

To configure profiles #1 to #6, select a name in the list. The **Local mesh profile** page opens.

General

Enabled/Disabled

Specify if the profile is enabled or disabled. The profile is only active when enabled.

Name

Name of the profile.

On dual-radio products use/On triple-radio products use

Select the radio to use for this link.

Settings

Mode

Three different roles can be assigned to a node: master, alternate master, or slave. The role assigned to a node, governs how the node will establish upstream or downstream links with its peers. The available configuration settings change depending on the role that is selected.

- **Master:** The master is the root node that provides the upstream connection to the ground network that the other nodes want to reach. The master will only create downstream local mesh links to alternate master or slave nodes.

- **Slave:** Slave nodes can only establish upstream links with master or alternate master nodes. Slave nodes cannot establish downstream links with other nodes.

Dynamic

Mode: Slave

Mesh ID: 1

Minimum SNR: 20

SNR cost per hop: 10

Allowed downtime: 10 seconds

Initial discovery time: 20 seconds

Promiscuous mode: 60 seconds

Preserve master link across reboots

Allow forced links

Search for better link on minimum SNR

Restart Discovery

- **Alternate Master:** An alternate master node must first establish an upstream link with a master or alternate master node before it can establish downstream connections with an alternate master or slave node.

Dynamic

Mode: Alternate Master

Mesh ID: 1

Minimum SNR: 20

SNR cost per hop: 10

Allowed downtime: 10 seconds

Maximum links: 9

Initial discovery time: 20 seconds

Promiscuous mode: 60 seconds

Preserve master link across reboots

Allow forced links

Search for better link on minimum SNR

Restart Discovery

Security

Enable this option to secure data transmitted on the wireless link. The APs on both sides of the wireless link must be configured with the same security options.

WEP

This feature has been deprecated. *If you are creating a new installation, use AES/CCMP. If you are upgrading from a previous release, your existing configuration will still work.*

Enables WEP to secure traffic on the wireless link.

Specify the encryption key the node will use to encrypt/decrypt all data it sends and receives. The key is 128 bits long and must be specified as 26 hexadecimal digits.

TKIP

This feature has been deprecated. *If you are creating a new installation, use **AES/CCMP** instead. If you are upgrading from a previous release, your existing configuration will still work.*

Enables TKIP encryption to secure traffic on the wireless link.

The node uses the key you specify in the PSK field to generate the TKIP keys that encrypt the wireless data stream.

Specify a key that is between 8 and 63 ASCII characters in length. HP recommends that the key be at least 20 characters long, and be a mix of letters and numbers.

AES/CCMP

Enables AES with CCMP encryption to secure traffic on the wireless link. This is the most secure method.

The node uses the key you specify in the PSK field to generate the keys that encrypt the wireless data stream.

Specify a key that is between 8 and 63 ASCII characters in length. HP recommends that the key be at least 20 characters long and be a mix of letters and numbers.

Settings

Three different roles can be assigned to a node: master, alternate master, or slave. The role assigned to a node, governs how the node will establish upstream or downstream links with its peers. The available configuration settings change depending on the role that is selected.

- **Master:** The master is the root node that provides the upstream connection to the ground network that the other nodes want to reach. The master will only create downstream local mesh links to alternate master or slave nodes.

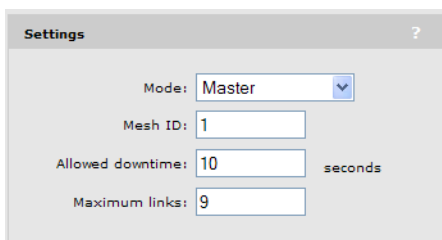

The screenshot shows the 'Settings' dialog for a Master node. The 'Mode' dropdown is set to 'Master'. The 'Mesh ID' is 1. The 'Allowed downtime' is 10 seconds. The 'Maximum links' is 9.

- **Slave:** Slave nodes can only establish upstream links with master or alternate master nodes. Slave nodes cannot establish downstream links with other nodes.

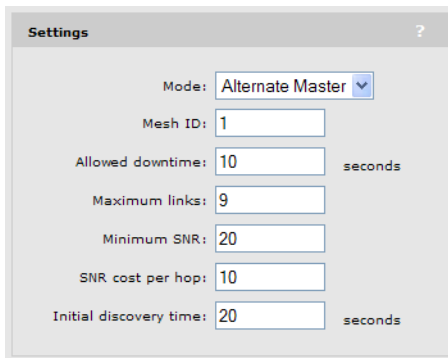

The screenshot shows the 'Settings' dialog for an Alternate Master node. The 'Mode' dropdown is set to 'Alternate Master'. The 'Mesh ID' is 1. The 'Allowed downtime' is 10 seconds. The 'Maximum links' is 9. The 'Minimum SNR' is 20. The 'SNR cost per hop' is 10. The 'Initial discovery time' is 20 seconds.

- **Alternate Master:** An alternate master node must first establish an upstream link with a master or alternate master node before it can establish downstream connections with an alternate master or slave node.

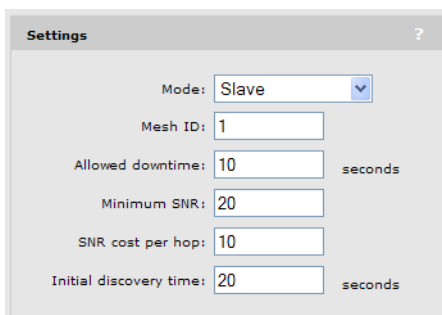

The screenshot shows the 'Settings' dialog for a Slave node. The 'Mode' dropdown is set to 'Slave'. The 'Mesh ID' is 1. The 'Allowed downtime' is 10 seconds. The 'Minimum SNR' is 20. The 'SNR cost per hop' is 10. The 'Initial discovery time' is 20 seconds.

Mesh ID

A unique number that identifies a series of nodes that can connect together to form a local mesh network.

Minimum SNR

(Alternate master or slave nodes)

This node will only connect with other nodes whose SNR is above this setting (in dB).

SNR cost per hop

(Alternate master or slave nodes)

This value is an estimate of the cost of a hop in terms of SNR. It indicates how much SNR a node is willing to sacrifice to connect to node one hop closer to the root node, because each hop has an impact on performance, especially when using a single radio.

Allowed downtime

The maximum time (in seconds) that a link can remain idle before the link actually gets deleted. When a slave (or alternate master) loses its link to its master, the discovery phase is re-initiated.

Maximum links

(Master or alternate master nodes)

The maximum number of upstream and downstream links that this node can support.

Initial discovery time

(Alternate master or slave nodes)

Amount of time that will be taken to discover the best available master node. The goal of this setting is to delay discovery until all the nodes in the surrounding area have had time to startup, making the identification of the best master more accurate. If this period is too short, a slave may connect to the first master it finds, not necessarily the best.

Provisioning local mesh links

APs operating in controlled mode must be able to discover and connect with a controller. When operating as part of a local mesh, *any AP that can **only** discover the controller via a wireless link must be provisioned* before being deployed. In this example, AP 1, AP 2, AP 4, and AP 5 must be provisioned prior to deployment for discovery to be successful. (Since AP 3 is using a wired link, it does not need to be provisioned for this scenario.)

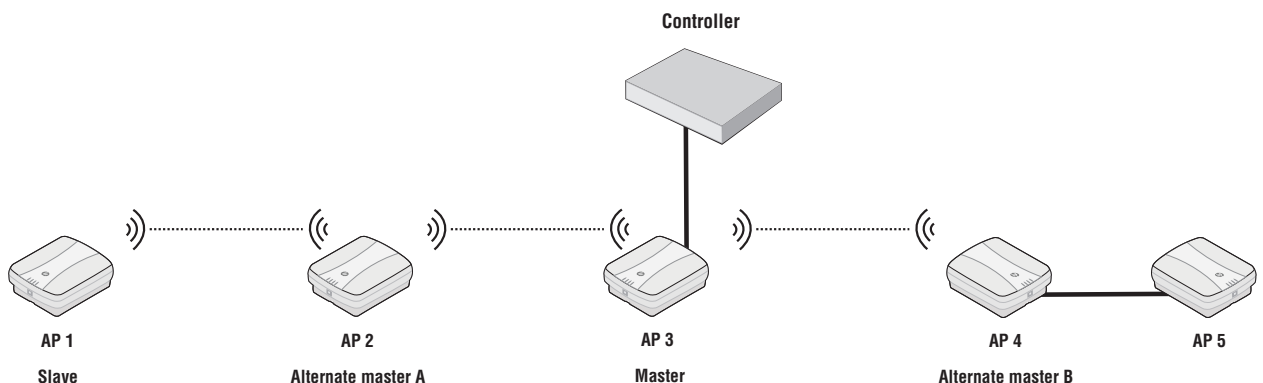

Provisioning is done before APs are deployed using either of the following methods:

- Directly connect to each AP and use its management tool to define provisioning settings.
- Connect the APs to the controller (either directly via the LAN port or through a local area network). After the APs are discovered, use the controller management tool to define provisioning settings by opening the **Provisioning > Connectivity** page at either the group or AP level.

In this example, AP 1, AP 2, and AP 4 are all provisioned with the same settings as follows:

Group: **Default Group** | Connectivity
 Inherited ?

Interface

↕
 Port 1

↕
 Local mesh

No VLAN
 VLAN ID:

Assign IP address via

DHCP client
 Static

Static IP settings

IP address:

Mask:

Default gateway:

Local mesh settings

Connect to:

Any mesh
 A mesh with ID:

Security:

Key:

Confirm key:

Country

802.1x

EAP Method:

Username:

Password:

Confirm password:

Anonymous:

Local mesh radio configuration

Product	Radio	Wireless mode	Antenna selection
MSM310	Radio 1	802.11g <input style="width: 20px;" type="button" value="v"/>	Diversity
MSM320	<input style="width: 50px;" type="text" value="Radio 1"/> <input style="width: 20px;" type="button" value="v"/>	802.11g <input style="width: 20px;" type="button" value="v"/>	Diversity
MSM422	<input style="width: 50px;" type="text" value="Radio 1"/> <input style="width: 20px;" type="button" value="v"/>	802.11n (5 GHz) <input style="width: 20px;" type="button" value="v"/>	<input style="width: 50px;" type="text" value="Internal"/> <input style="width: 20px;" type="button" value="v"/>
MSM335	<input style="width: 50px;" type="text" value="Radio 1"/> <input style="width: 20px;" type="button" value="v"/>	802.11g <input style="width: 20px;" type="button" value="v"/>	<input style="width: 50px;" type="text" value="Internal"/> <input style="width: 20px;" type="button" value="v"/>
MSM410	Radio 1	802.11n (5 GHz) <input style="width: 20px;" type="button" value="v"/>	Diversity
E-MSM460	<input style="width: 50px;" type="text" value="Radio 1"/> <input style="width: 20px;" type="button" value="v"/>	802.11n/a <input style="width: 20px;" type="button" value="v"/>	Internal
E-MSM430	<input style="width: 50px;" type="text" value="Radio 1"/> <input style="width: 20px;" type="button" value="v"/>	802.11n/a <input style="width: 20px;" type="button" value="v"/>	Internal
E-MSM466	<input style="width: 50px;" type="text" value="Radio 1"/> <input style="width: 20px;" type="button" value="v"/>	802.11n/a <input style="width: 20px;" type="button" value="v"/>	External
E-MSM466-R	<input style="width: 50px;" type="text" value="Radio 1"/> <input style="width: 20px;" type="button" value="v"/>	802.11n/a <input style="width: 20px;" type="button" value="v"/>	External

Use the Local mesh radio configuration table to define local mesh settings for each product type.

- **Product:** Indicates the product type.
- **Radio:** Select the radio that will be used for the local mesh.

- **Wireless mode:** Select the wireless mode that will be used for the local mesh.
- **Antenna selection:** Select the antenna(s) on which the radio transmits and receives.
 - **Internal:** The internal antenna is used to transmit and receive.
 - **External:** The external antenna is used to transmit and receive.

NOTE: All APs must all be configured for the same country so that the local mesh established respects local RF regulations. To define the country setting, see [“Assigning country settings to a group” \(page 170\)](#).

The local mesh provisioning profile for AP 2 needs to be set to alternate master mode so that it can support a connection from AP 1. Select AP 2 in the **Network Tree** and then open the **Configuration > Local mesh** page and select **Local mesh provisioning profile**.

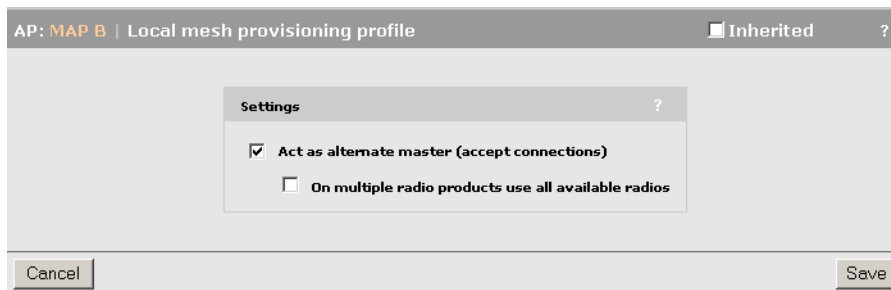

NOTE: To enable the controller to send provisioned settings to controlled APs, activate the **Enable provisioning of controlled APs** option on the **Controller >> Controlled APs > Provisioning** page.



Until this option is enabled, provisioned settings defined on the controller are not sent to any controlled APs.

Once provisioning settings have been defined you need to update all controlled APs with the new settings by synchronizing them as described in [“Synchronizing APs” \(page 164\)](#).

After an AP has been updated with provisioned settings, the provisioned settings do not become active until the AP is restarted, or a **Remove and Rediscover** action is executed on the **Controlled APs >> Configured APs** page.

Sample local mesh deployments

RF extension

Local mesh provides an effective solution for extending wireless coverage in situations where it is impractical or expensive to run cabling to an AP.

In this scenario, a wireless bridge is used to extend coverage of the wireless network. Both APs are equipped with omni-directional antennas, enabling them to deliver both AP capabilities and wireless bridging using local mesh capabilities.

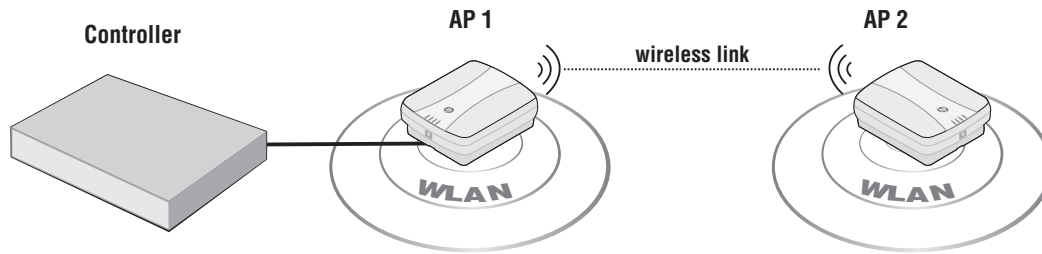

Building-to-building connection

You can also use local mesh to create point-to-point links over longer distances. In this scenario, two dual-radio APs create a wireless link between networks in two adjacent buildings. Each AP is equipped with a directional external antenna attached to radio 1 to provide the wireless link. Omnidirectional antennas are installed on radio 2 to provide AP capabilities. The two APs are placed within line of sight.

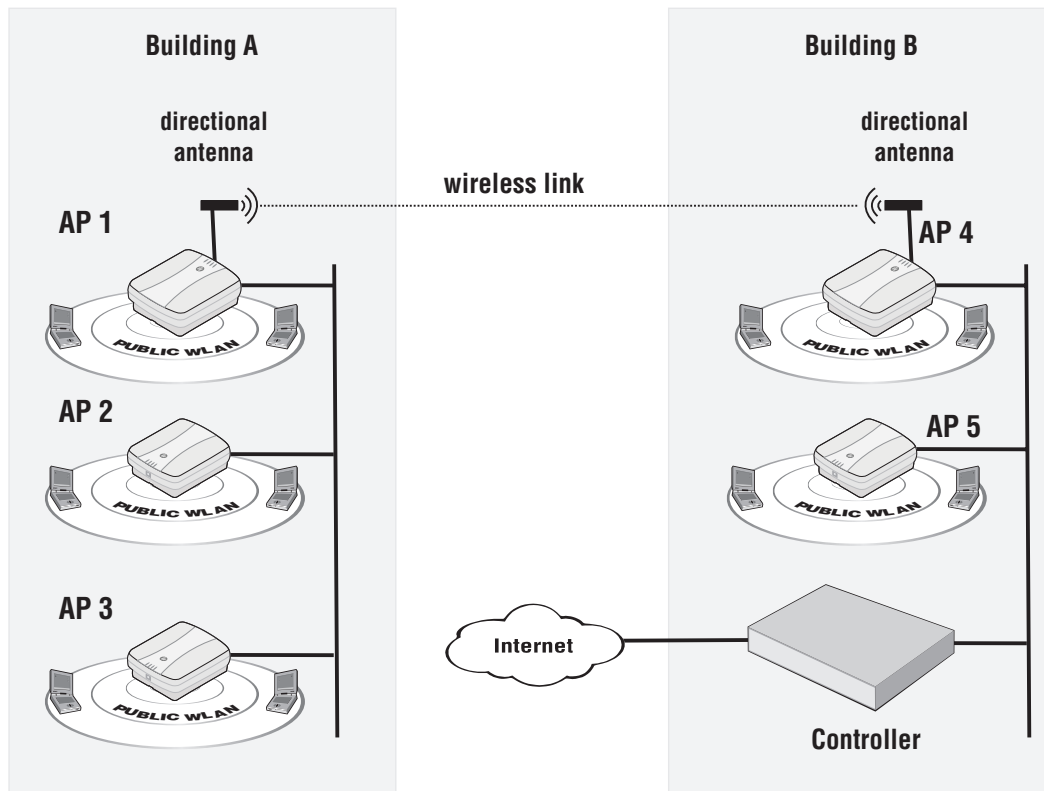

NOTE: In the above example, all APs must connect to the backbone network via port 1.

Dynamic network

In this scenario, a controller is deployed with several APs to provide wireless coverage of a large area. Instead of using a backbone LAN, wireless links are used to interconnect all APs.

AP 1 is the *master*. It provides the connection to the wired network and a wireless link to the other APs. The other APs automatically established their links to the master based on a balance between SNR (signal to noise ratio) and hops, to provide the most efficient network topology.

If a node becomes unavailable, the links dynamically adjust to find the optimum path to the master.

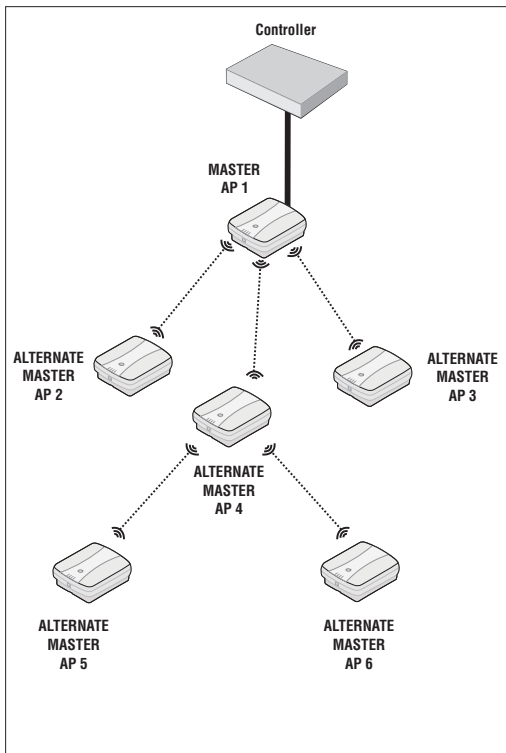

Initial network configuration is automatically established.

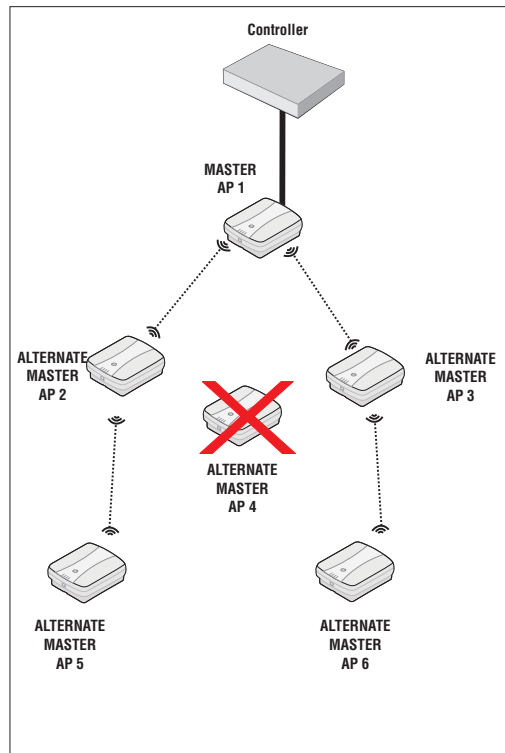

When AP 4 is unavailable, the network dynamically reconfigures itself.

20 Public/guest network access

Introduction

The *Public/Guest Network Access* feature enables you to provide controlled network access for a variety of deployments. Some common applications of this feature are:

- Providing Internet access to wireless customers in airports, restaurants, train stations, conference halls, etc.
- Providing wireless and wired access to staff and guests in hospitals, corporations, and government buildings.
- Providing wireless and wired access to students, staff, and teachers in schools and universities.
- Providing outdoor wireless access for an entire town, enabling city workers, police, fire, public security, and the general public to connect.

This chapter provides describes the public/guest network access feature and how it can be used. For detailed information on the RADIUS attributes that can be used to customize the public access interface, see [“Working with RADIUS attributes”](#) (page 435)

Key concepts

Access control

When the **Access control** option is enabled on a VSC, it creates an **access-controlled VSC**. This means that for all traffic on the VSC, the controller acts as the gatekeeper between two distinct network segments: the *public network* and the *protected network*.

- **Public network:** Access to the public network and its resources is generally made available to all unauthenticated wireless users once they successfully connect to the wireless network. Access is also generally made available to unauthenticated wired users on any network that is connected to the controller LAN port.
- **Protected network:** Access to the protected network is restricted by the controller and typically requires that users be authenticated by the controller before they gain access. Various authentication methods are available (HTML-based, MAC-based, 802.1X). The most commonly used method is HTML-based, which enables users to login through their Web browsers via the public access interface Login page. The controller can validate user login credentials using locally defined user accounts or by using the services of a third-party authentication server (RADIUS or Active Directory).

The following diagrams illustrates a basic setup in which a wireless user is authenticated by an access-controlled VSC and then gains access to a corporate network.

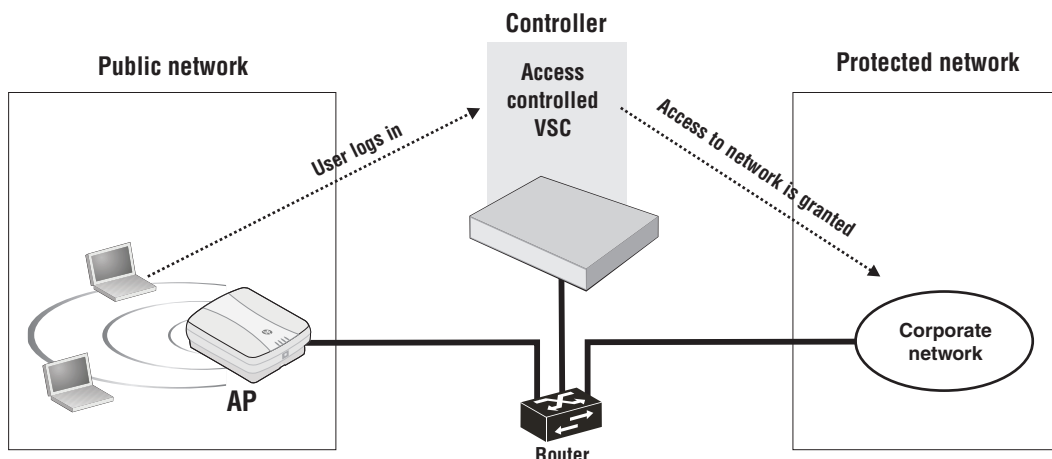

For more information on access control, see [“Configuring global access control options”](#) (page 399).

NOTE: If authentication is not enabled on a VSC, all users connected to the VSC can access the protected network.

Access lists

An access list is a set of rules that governs how the controller manages access to the public and private network resources. You can create multiple access lists, each with multiple rules, enabling you to create public areas on your network that all users can browse, and protected areas that are restricted to specific user accounts or groups.

For more information, see [“Access list”](#) (page 484).

In the following example, access lists are defined to allow the following levels of access:

- Unauthenticated users can access Network 1.
- Authenticated employees can access Network 2 and the Internet.
- Authenticated guests can access the Network 3 and the Internet.

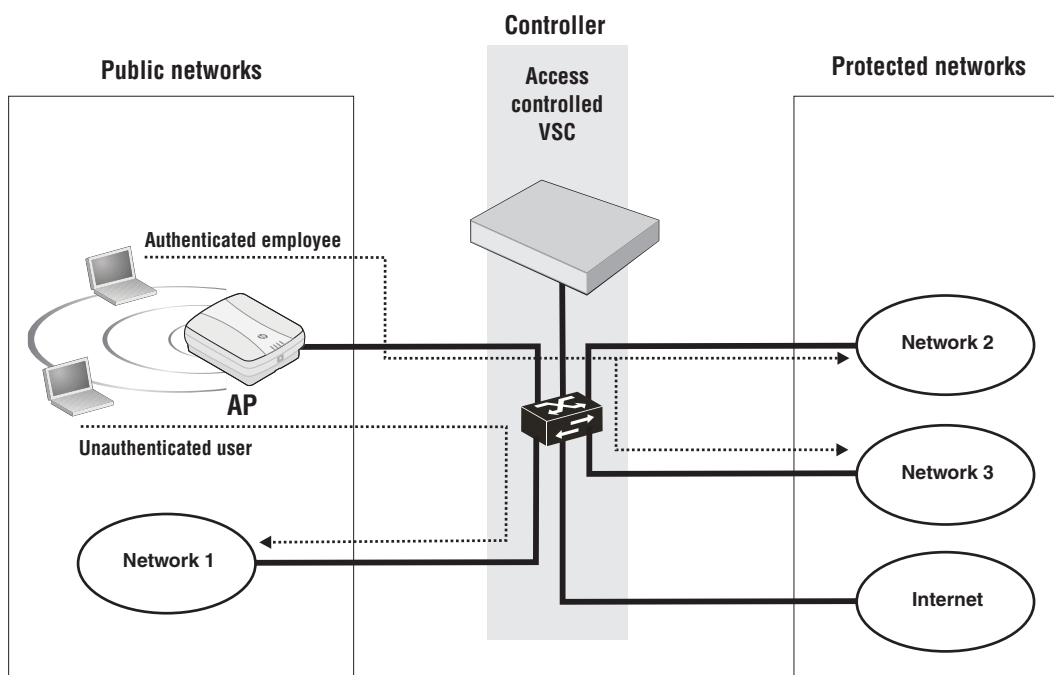

The public access interface

The *public access interface* is the sequence of Web pages through which access-controlled users can log in, log out, and view the status of their wireless connections to the public access network. By default, these Web pages are hosted on the controllers Web server. However, pages can also be hosted on external servers for added flexibility. The pages, error messages, images, and workflow are all customizable.

Standard pages are provided for common tasks such as login, service purchase, and display of session information. As well, advertisements can be displayed if required.

When a wireless user attempts to browse a Web site that is on the protected network, the user is redirected to the public access interface Login page. The default page looks similar to this:

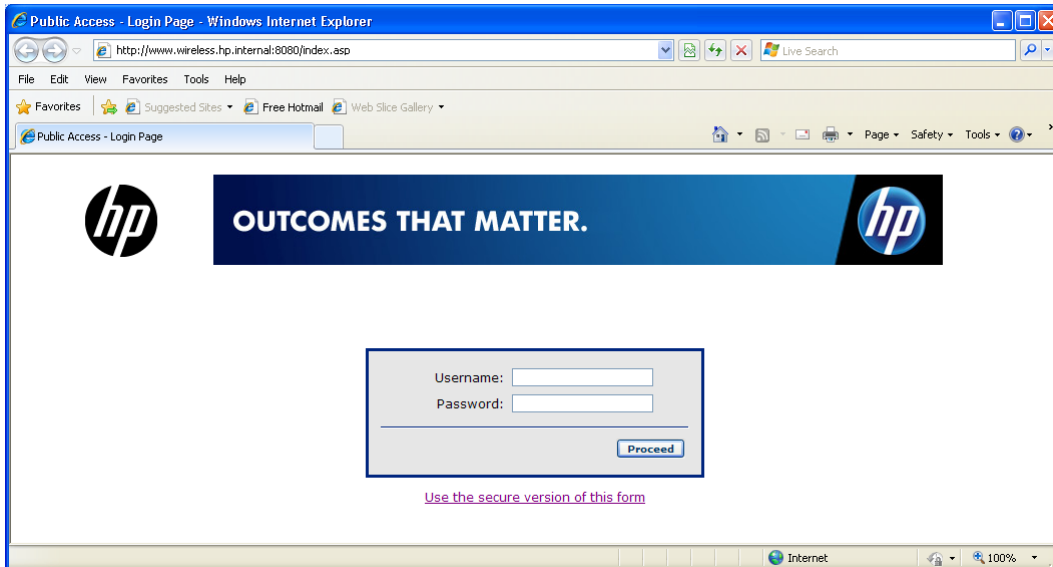

After the user successfully logs in, the session and welcome pages appear.

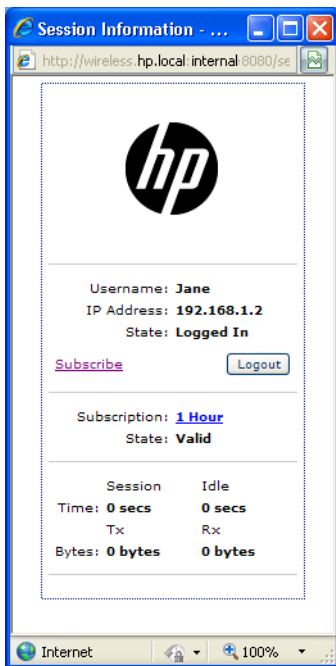

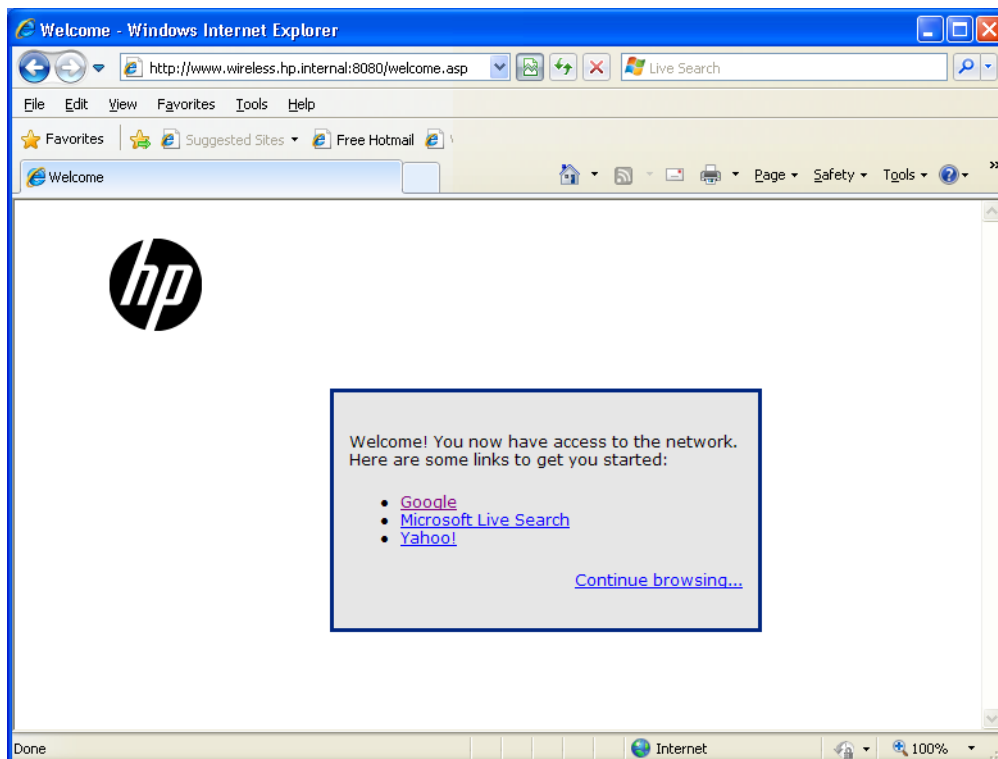

The session page provides details on the users session, and a Logout button. The welcome page is the starting point for the user once logged in. You can customize this page to present important information about your network.

If the user selects **Continue browsing**, they are redirected to the original Web site that they were attempting to reach after they associated with the wireless network.

When done browsing, the user selects **Logout** on the session page to terminate their session.

For more information on the public access Web pages, see:

- [“Public access interface control flow” \(page 403\)](#)
- [“Customizing the public access interface” \(page 405\)](#)

Location-aware

The location-aware feature enables you to control logins to the public access network based on the wireless AP to which a user is connected. It is configured on a per-VSC basis.

When enabled, the controller returns location-specific information for RADIUS-authenticated users. This information can be retrieved and processed by server side scripts to manage network access.

For more information, see [“Location-aware authentication” \(page 432\)](#).

Configuring global access control options

Global access control settings are managed by selecting **Controller >> Public access > Access control**.

The access control mechanism is used by the controller to manage user access to network resources. Access control is applied on a per-VSC basis. When the **Use Controller for Access control** option is enabled on a VSC, the configuration options on this page take effect with regards to client station configuration, authentication, and authorization.

Use the checkbox in the title bar to globally enable or disable the access control mechanism:

- When enabled, the controller provides access control functionality which can then be configured on a per-VSC basis.
- When disabled, the Public/Guest Network Access feature is disabled for all VSCs that are configured to use access control.

The status light indicates the state of the authentication system.

- **Green:** Access control is working and authentication requests can be processed.
- **Red:** Access control cannot process authentication requests at this time.

User authentication

Allow access if authentication timed out

Enable this option to give users free access to the protected network if authentication services configured for a VSC are unavailable. Once the authentication services are available again, free user sessions remain active until the user logs out.

For example, if a user is connected to a VSC configured for HTML-based authentication using a RADIUS server, and the RADIUS server is not responding, the user will be granted free access to the network using the settings from the default user profile (Default AC).

NOTE: This feature does not work for users configured to use 802.1X or WPA when the encryption keys are provided by the RADIUS server.

Add idle-timeout to RADIUS accounting session-time

When enabled, the controller includes the idle time-out in the total session time for a user when the session is terminated due to idle time-out.

To remove the idle time-out from the total session time, disable this option.

Automatically reauthenticate HTML-based users for nn min

When this option is enabled, you can specify the amount of time that the controller will remember the login credentials for an HTML-based user after they log out. If the user reconnects to the network before this timeout expires, they are automatically logged in, and instead of being redirected to the Login page, they are redirected to the Welcome-back page.

For this feature to work, users must have successfully been logged in at least once via HTML and must have the same IP address and MAC address as their initial login when they return. Also, the session must have been terminated involuntarily. For example, by the user moving out of range, or their computer being restarted. If the user terminates their session, they will not be automatically re-authenticated.

To support this functionality, the DHCP server on the controller needs to be enabled. It will attempt to reserve a users assigned DHCP addresses even after their lease time has expired. As long as free addresses remain in the DHCP address pool, the expired address will not be reassigned to a new user.

NOTE:

- The controller remembers login credentials even if the controller is restarted for administrative reasons.
 - This feature may not work for users whose actual IP or MAC address is hidden by an intervening router or other network device.
-

Reauthenticate users on location change

When this option is enabled, the controller will automatically reauthenticate users when they switch to:

- a wireless cell with a different SSID
 - a different VLAN ID on the same VSC
 - an AP with a different MAC address
 - an AP with a different group name
 - a different wireless mode
-

NOTE: This feature is only supported when using an external RADIUS server for authentication tasks.

Maximum concurrently authenticated public access users

Specify the maximum number of users that can be authenticated and logged into the public access interface at the same time.

Client polling

The controller polls authenticated client stations to ensure that they are active. If no response is received and the number of specified retries is reached, the client station is disconnected. To use this feature, client stations must have L2 connectivity to the controller.

This feature enables the controller to detect if two client stations are using the same IP address but have different MAC addresses. If this occurs, access is terminated for this IP address removing both stations from the network.

Changing these values may have security implications. A large interval provides a greater opportunity for a session to be hijacked.

The initial query is always done after the client station has been idle for 60 seconds. If there is no answer to this query, the settings for **Interval** and **Retries** are used to control additional retries.

Polling interval

Specify how long to wait between polls.

Consecutive retries

Specify how many consecutive polls to which a client station can fail to reply before it is disconnected.

User agent filtering

Enable this option to filter and stop redirection of HTTP login requests coming from unauthorized client applications. Filtering occurs via the user-agent string that web-based applications use to identify themselves to their peers.

Blocked agents

This is the list of user-agent strings that the controller will use to block client applications. If an applications user-agent string appears in this list, it will be blocked.

When the list is empty, all valid HTTP login requests are redirected.

For example, add the word **Torrent** to the list to stop HTTP login requests coming from the BitTorrent 6.3 client application.

A list of user agents strings can be found here: <http://www.useragentstring.com/pages/useragentstring.php>

Zero configuration

Support applications that use

- **HTTP/HTTPS proxy:** Enable this option to allow the controller to support client stations that use application software (such as a web browser) configured to use a proxy server for HTTP and HTTPS, without reconfiguration of the application software.

When this feature is enabled, ensure that client stations:

- Do not use a proxy server on ports 21, 23, 25, 110, 443, 8080, or 8090. To support ports 8080 and 8090, change the port settings under **Controller >> Public access > Web server > Ports**.
 - Use the same proxy server address and port number for both HTTP and HTTPS.
 - **Restrict proxy support to users authenticated via HTML:** Enable this option to restrict proxy support to users who logged in via the public access login page.
- **SMTP authentication:** When the controller redirects user SMTP traffic, the server to which the traffic is redirected may need to authenticate the controller. Enable this option to allow the controller to supply a username and password to the server. You can define the username and password in the RADIUS account for the controller or for the user.

Location configuration

These values are returned to IPass clients, and are also sent in RADIUS Authentication Access Requests and Accounting Requests for all users authenticated by this controller.

Location ID

Specify the WISPr location ID assigned to the controller.

Location name

Specify the WISPr location name assigned to the controller.

Display advertisements

When this option is enabled, it causes users to be redirected to an ad content page while they are browsing.

The ads page can be either `ads.asp` or `ads-frameset.asp`, depending on the setting of **Use frames when presenting ads** under **Site options** on the **Public access > Web content** page.

Redirection occurs on TCP port 80.

Display advertisements every nnn sec

Specify the interval at which users are redirected to the ads page.

NOTE: Once the **Display advertisements** option is enabled, advertisements are displayed for all users. You can selectively disable the display of advertising in user profiles (**Controller >> Users > Account profiles**), subscription plans (**Controller >> Users > Subscription plans**), or via attributes set in a users RADIUS account.

Public access interface control flow

The two following diagrams provide an overview of the default public access interface Web page flow. All site Web pages are identified by their role: **Login**, **Welcome**, **Logout**, etc. This abstraction is used because the name of the actual page used for a particular role is configurable in many cases. (For reference, the page name used by the factory default configuration is provided in parenthesis.)

For a description of the individual pages, see [“Current site files”](#) (page 414).

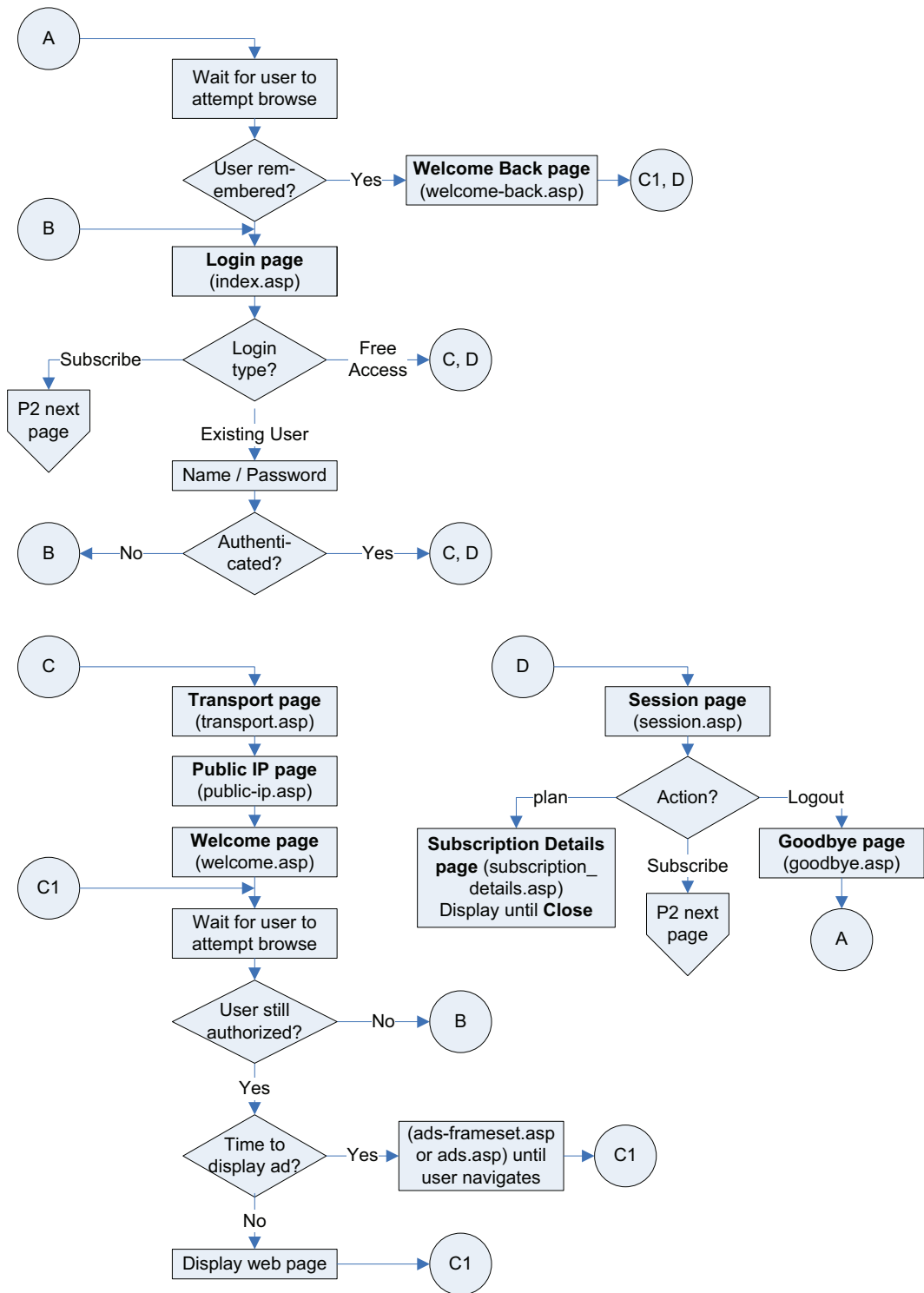

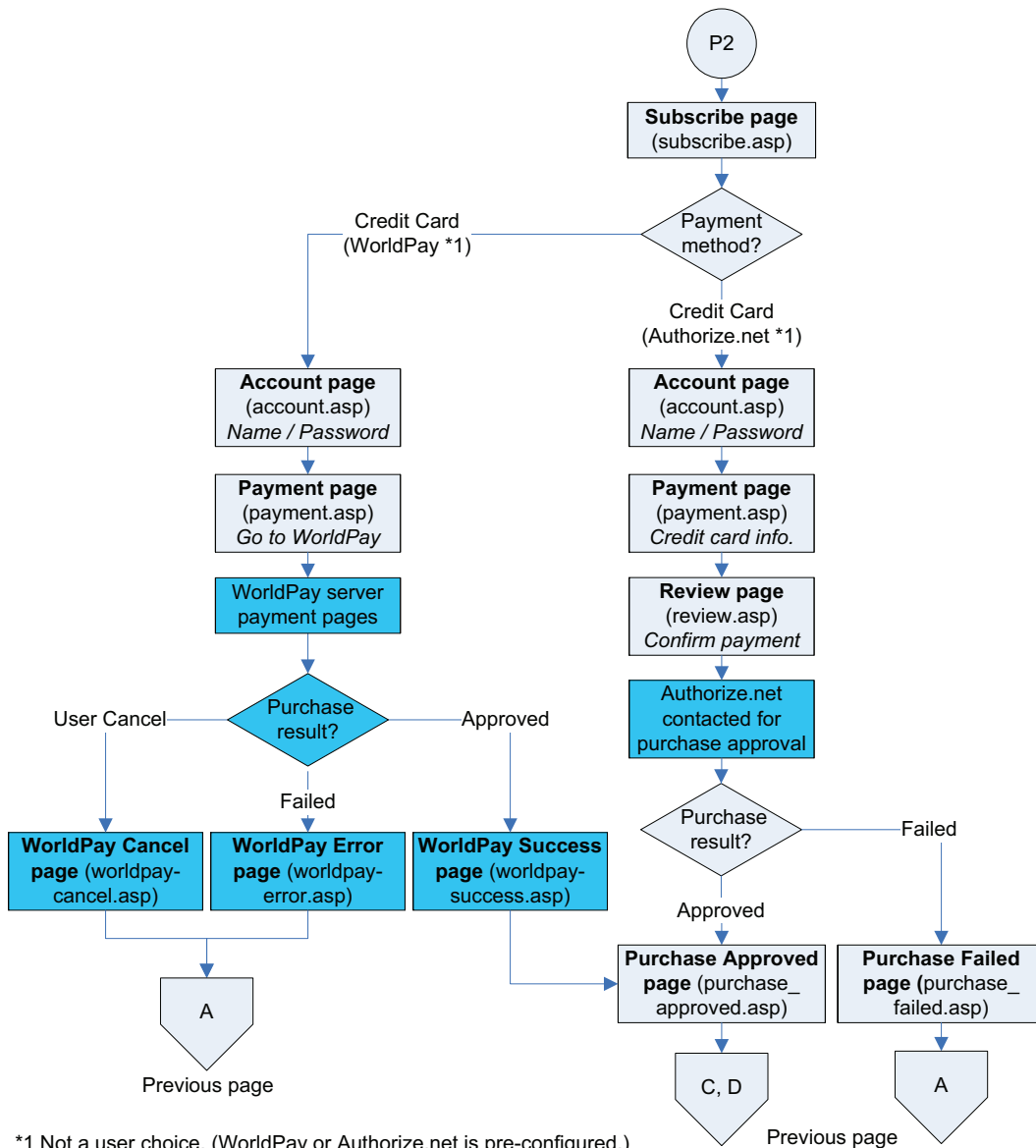

Customizing the public access interface

The public access interface can be customized using the methods described below. You might use one or more of these methods, depending on the type of customization that you want to perform.

- Setting site configuration options:** The site configuration options on the **Controller >> Public access > Web content** page can be used to quickly enable/disable certain public access features.
 See ["Setting site configuration options"](#) (page 409).
- Customizing the public access interface Web pages:** The Web pages hosted on the controller internal Web server can be modified, allowing the entire public access interface to be customized. Simple modifications can be made with basic knowledge of HTML. Users with

advanced HTML skills and knowledge of ASP and Javascript will be able to fully-customize all site operations.

See “Customizing the public access Web pages” (page 412).

- **Setting public access attributes:** Configuration of a number of public access features can be accomplished by setting various RADIUS attributes. There categories of attributes are available:
 - **Site attributes:** These attributes are used to configure site-related options and global settings that apply to all user sessions. They can be defined in the RADIUS account for the controller or reside locally on the controller.
See “Controller attributes overview” (page 435).
 - **User attributes:** These attributes are used to customize settings on a per-user basis. These attributes can reside locally on the controller or be retrieved from a third-party RADIUS server.
See “Defining and retrieving user attributes” (page 443).

Sample public access pages

Some of the examples in this chapter make use of files contained in the `Public Access Examples` zip file. This file is available at www.hp.com/networking/public-access-examples.

Common configuration tasks

Customizing the login, welcome, or goodbye page

1. Select **Controller >> Public access > Web content**.
2. Under **Current site files**, select one of the following files:

Login page: `index.asp`

Welcome page: `welcome.asp`

Goodbye page: `goodbye.asp`

3. The file will appear in the built-in text editor. Change the file to meet the requirements of your site.
4. Select **Save**.

Customizing the logo

1. Create a file called `logo.gif` that contains your logo (recommended size less than 20K).
2. Select **Controller >> Public access > Web content**.
3. Under **Current site files**, select the garbage can icon to the right of `logo.gif` to delete it.
4. Select **Add New File**.
5. For **Filename**, specify `logo.gif`.
6. Next to **Load binary content**, select **Browse**.
7. Select the `logo.gif` file that you created in Step 1.
8. Select **Load**.

Displaying custom welcome and goodbye pages

This example shows how to display unique welcome and goodbye pages for specific users or groups of users. This example assumes that you are hosting the web pages are hosted on a remote server and that you are using a RADIUS server to authenticate users.

For this example, assume that you have two sets of users: basic and premium. To distinguish the two groups, you have set up the user accounts on the RADIUS server accordingly. (Perhaps you

are using access lists to restrict each group to a different section of the public network as described in “Access list example” (page 464)).

1. Retrieve the Public Access Examples zip file at www.hp.com/networking/public-access-examples.
2. Create the following two folders on your Web server: `basic` and `premium`.
3. Copy the files `welcome.html` and `goodbye.html` from the Examples zip file into both the `basic` and `premium` folders on the web server.
4. Edit the pages to present customized welcome and goodbye content for each set of users.
5. Add the following entry to the RADIUS profile for the basic users:

```
welcome-url=web_server_URL/basic/welcome.html  
goodbye-url=web_server_URL/basic/goodbye.html
```
6. Add the following entry to the RADIUS profile for the premium users:

```
welcome-url=web_server_URL/premium/welcome.html  
goodbye-url=web_server_URL/premium/goodbye.html
```
7. Add the following entry to the RADIUS profile for the controller. This gives all unauthenticated users access to the Web server hosting the goodbye page.

```
access-list=loginserver,ACCEPT,tcp,web_server_IP_address,port_number
```

Delivering dynamically generated content

Another way to generate custom pages is to add placeholders in the URLs for the custom external pages and then use server-side scripting to dynamically create the pages. This method provides a powerful mechanism to automatically generate completely customized pages on a per-user basis. Rather than designing one or more static pages, as in the previous example, the custom pages in this example can be built on-the-fly based on user preferences stored in a central database, or based on a users location within the network.

For example, if you want to generate a custom welcome page for each user:

1. Add the following entry to the RADIUS profile for the controller.

```
welcome-url=web_server_URL/custom/  
welcome.html?loginname=%u&IPAddress=%I
```
2. Create a server-side script to retrieve the users login name (%u) and the controller IP address or domain name (%u). The script can use this information to then display a custom page based on users preferences (stored in the server database) and the users location within the wireless network.

Supporting smartphones

Users with smartphones that only support a single browser window will have difficulty using the public access interface in its standard configuration.

Once a user logs in to the public access interface, two Web pages are sent to their browser: the Welcome page and the Session page.

The Session page contains a logout button. Users who are unable to view this page will not be able to log out.

To solve the problem, modify the Welcome page to include a logout button.

1. Create a folder called **SmartPhoneUsers** on your Web sever.
2. See “Sample public access pages” (page 406). Copy public access sample files **welcome.html** and **goodbye.html** into the **SmartPhoneUsers** folder.
3. Edit **welcome.html** to include a logout link with the target:

```
http://controller_name:port/goform/HtmlLogout.
```

For example:

```
http://wireless.mycompany.com:8080/goform/HtmlLogout.
```

Adds a warning to this page that tells smartphone users to bookmark the Welcome page so that they can logout.

4. Add the following entry to the RADIUS profile for all smartphone users:

```
welcome-url=web_server_URL/PDAusers/welcome.html
```

Customizing error messages

To customize the error messages, edit the appropriate messages in the files listed in the following table, using the **Controller >> Public access > Web content** page.

If an error occurs on	Messages are taken from
Login page (index.asp)	login_error_message.asp
Subscription page (subscribe.asp), Account page (account.asp), Payment page (payment.asp), Review page (review.asp), Purchase failed page (purchase_failed.asp)	subscription_error_message.asp
Other pages	Messages.txt

Logout host name

Logout IP address

These two options enable easy logout from the public access network. Users can logout by pointing their browsers to a specific host name or its IP address.

Host names must be fully-qualified, which means they must include the domain name suffix (.suffix). For example: mydomain.com is fully qualified, mydomain is not.

If a user that is logged in via HTML sends an HTTP request to the specified host name or IP address, the controller will log the user out.

To use this option you must define an access list with the DNAT option. For example, if the controller LAN port is at **192.168.1.1** and you want to logout users when they access network.logout (which has an IP address of 10.10.1.1) you would define the following:

```
Logout host name = network.logout
```

```
Logout IP address = 10.10.1.1
```

On the **Controller >> Public access > Attributes** page, add the following attributes under **Configured attributes**:

```
dnat-server = logout, 192.168.1.1, 8081
```

The DNAT-SERVER has to point to the controller's LAN port on TCP port 8081. This is where the logout service is located on the controller.

```
access-list = logout,DNAT-SERVER,tcp,10.10.1.1,80
```

Indicates that TCP traffic on port 80 that is addressed to 10.10.1.1 will be forwarded to the DNAT-SERVER (192.168.1.1).

```
use-access-list=logout
```

Activates the access list for all users on the controller.

How it works

1. When a user enters **http://network.logout** in their browser, the controller resolves it to **10.10.1.1**.
2. The controller then intercepts any TCP traffic destined for 10.10.1.1 on port 80 and redirects it to 192.168.1.1 on port 8081.
3. The logout service running on controller port 8081 then logs the user out.

Setting site configuration options

To view, edit, and manage site options, select **Controller >> Public access > Web content** and configure the settings under **Site options**.

Manage public access web site content

Site options

- Allow subscription plan purchases
 - Allow creation of user accounts
 - Limit to new accounts in sec.
 - Delete user accounts when
 - Invalid/expired for hours
 - Not activated after hours
 - Display the Free Access option
 - Free accounts are valid for mins
 - Free access lockout time hours
- Support a local Welcome page
- Use frames when presenting ads
- HTML authentication:
- FIPS compliant operation
- Redirect users to the Login page via:
 - HTTP
 - HTTPS

Site file archive

Save current site files to archive

Overwrite current site files from archive

Archive name:

FTP server

URL Params HMAC tag

- HMAC tag required
 - HMAC tag secret:
 - Confirm HMAC tag secret:

About ASP variables

A number of ASP variables are defined for use by the public access interface pages. These variables are used to make configuration and status information available via ASP function calls, allowing for customization of the Web pages. Some of the site configuration options set the values of these variables. See [“Public access interface ASP functions and variables”](#) (page 490).

Allow subscription plan purchases

When enabled, the **Subscribe to this service** option is displayed on the default Login page (`index.asp`).

Subscribe to the service

Existing User

Username:

Password:

[Use the secure version of this form](#)

This option provides a link to the default Subscription page (`subscribe.asp`), where users can choose one of the subscription plans defined on the **Controller >> Users > Subscription plans** page. Existing users must enter their username and password to update their current account. New users enter a username and password to create a new account.

Pre-requisites

To use this feature, the following items must be pre-configured:

- One or more subscription plans must be defined by selecting **Controller >> Users > Subscription plans**.
- To support *credit card* payments, the credit card payment service must be enabled and configured by selecting **Controller >> Public access > Payment services**.

Display the Free Access option

When enabled, the Free Access option is displayed on the default Login page (`index.asp`). This enables users to login to the public access interface without paying.

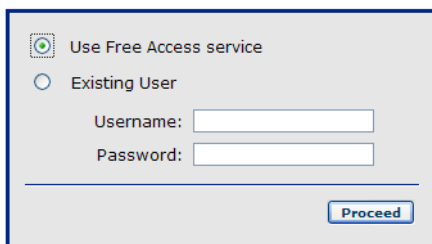

The screenshot shows a login form with the following elements:

- A checked radio button labeled "Use Free Access service".
- An unchecked radio button labeled "Existing User".
- Below the "Existing User" option, there are two input fields: "Username:" and "Password:".
- A "Proceed" button is located at the bottom right of the form.

[Use the secure version of this form](#)

A user account is automatically created for each user that selects the Free Access option. Each account has the following properties:

- The account name and password are set to the MAC address of the users device.
- The account is valid for up to 30 minutes from the time it is created. To change this time use the **Free accounts are valid for *nn* minutes** option. When a Free Access account expires, the user is blocked from using another free account until the free access lock out time expires.
- Account settings are imported from the **Default AC** profile. See ["About the Default AC profile" \(page 351\)](#).

Free accounts are valid for *nn* minutes

Specify how many minutes a free account is valid, starting from the time the user logs in with the Free Access option.

Free access lock out time *nn* hours

Specify how many hours a user is blocked from using the free account option after their initial free account expires. When a user creates a free account, the controller records the MAC address of the client station from which the user logged in. This MAC address is then blocked from reusing the free access option for the specified number of hours. If you change the setting for this parameter while a user is blocked, the user is unblocked after the original setting expires. Range: 1 to 720 hours.

Support a local Welcome page

Use this feature to host the Welcome page on the controller Web server.

- When enabled, users are redirected to `welcome.asp` on the controller Web server.
- When disabled, you can use the `welcome-url` attribute (see “Default user URLs” (page 475)) to define a remotely hosted welcome page.

Use frames when presenting ads

This option controls how advertising is displayed:

- When this option is enabled, the logo and advertisement displayed in a frame at the top of the page.

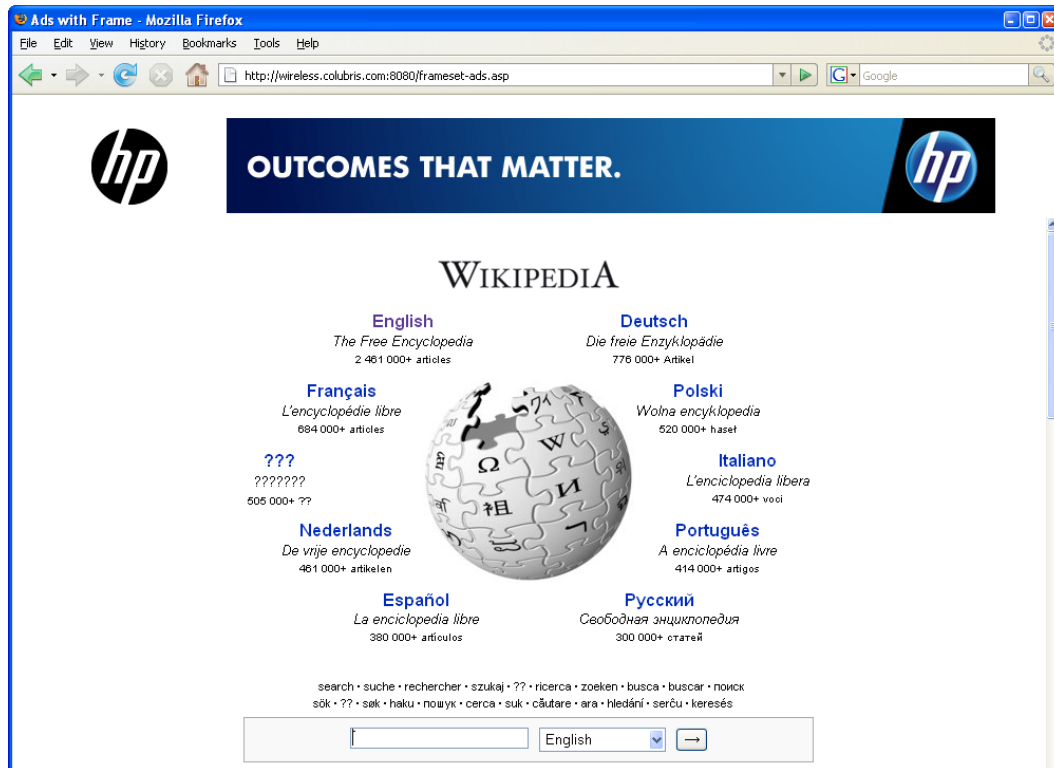

- When this option is disabled, the logo and advertisement are displayed on a separate page. The user selects **Continue browsing** to return to the page they were viewing.

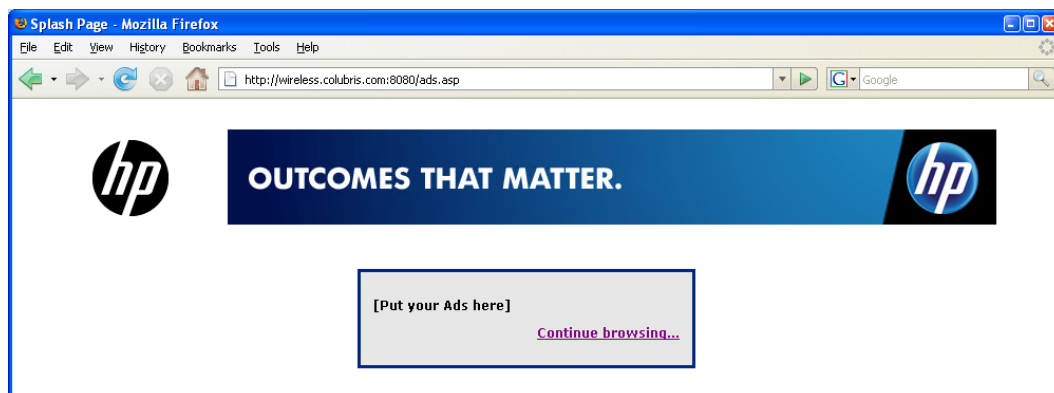

For more information on how advertising works, see “Display advertisements” (page 403).

Allow SSLv2 authentication

Enable this option to support client stations that use SSL v2 for their HTTPS connections. When disabled, the controller only supports client stations that are using SSL v3 for HTTPS connections. SSL v2 clients are refused.

Redirect users to the Login page via

Select the protocol that will be used when redirecting users to the default Login page (`index.asp`).

- **HTTP:** This option does not provide any encryption for protecting user login credentials.
- **HTTPS:** Provides a secure connection to protect user login credentials. However, until the default SSL certificate that is installed on the controller is replaced with a certificate signed by a well-known certificate authority, users will see a certificate warning message each time they attempt to log in. See “[Managing certificates](#)” (page 376) for more information on replacing the SSL certificate.

Customizing the public access Web pages

To view, edit, and customize the public access interface Web pages, select **Controller >> Public access > Web content**.

The screenshot shows the 'Manage public access web site content' configuration page. It is divided into four main sections:

- Site options:** Contains several checkboxes and input fields. 'Allow subscription plan purchases' is unchecked. 'Allow creation of user accounts' is unchecked, with a limit of 5 new accounts in 300 seconds. 'Delete user accounts when' has two options: 'Invalid/expired for 72 hours' (unchecked) and 'Not activated after 72 hours' (unchecked). 'Display the Free Access option' is unchecked, with free accounts valid for 30 minutes and a free access lockout time of 24 hours.
- Site file archive:** Contains a 'Save current site files to archive' button (labeled 'Save Archive') and an 'Overwrite current site files from archive' section with an 'Archive name:' input field (labeled 'Browse...') and a 'Load Archive' button.
- FTP server:** Contains a 'Configure...' button.
- URL Params HMAC tag:** Contains a checked 'HMAC tag required' checkbox, an 'HMAC tag secret:' input field, and a 'Confirm HMAC tag secret:' input field.

A 'Save' button is located at the bottom right of the page.

Site file archive

Use these options to manage the files on the Web server as a single archive file (zip format).

Save current site files to archive

Saves all the current site files to an archive file.

Overwrite current site files from archive

Select **Load Archive** to load all the site files from an archive, overwriting the currently installed site files.

FTP server

The FTP server provides an easy way to manage the public access interface files on the Web server, allowing you to use third-party Web site editing tools to customize content.

Select **Configure** to its define operational settings.

On the MSM720

The screenshot shows the 'FTP server configuration' window for the MSM720 controller. It is divided into two main sections: 'User' and 'Security'.
The 'User' section contains two input fields: 'Username:' and 'Password:'.
The 'Security' section contains:
- 'Allowed addresses:' with 'IP address:' and 'Mask:' input fields, an 'Add' button, and a list area with a 'Remove Selected Entry' button below it.
- 'Active Interfaces:' with a list of three items: 'Access network' (checked), 'Internet network' (unchecked), and 'VPN' (unchecked).
A 'Save' button is located at the bottom right of the window.

On all other controllers

The screenshot shows the 'FTP server configuration' window for other controllers. It is divided into two main sections: 'User' and 'Security'.
The 'User' section contains two input fields: 'Username:' and 'Password:'.
The 'Security' section contains:
- 'Allowed addresses:' with 'IP address:' and 'Mask:' input fields, an 'Add' button, and a list area with a 'Remove Selected Entry' button below it.
- 'Active Interfaces:' with a list of three items: 'LAN port' (checked), 'Internet port' (unchecked), and 'VPN' (unchecked).
A 'Save' button is located at the bottom right of the window.

NOTE: For security reasons you should disable the FTP server once the controller is deployed. Or at minimum, define security filters to restrict FTP access.

User

Specify the username and password that will be required when connecting to the FTP server.

NOTE: When using FTP, the username and password are not encrypted. They are sent as clear text.

Security

Allowed addresses

Enables you to define a list of IP address from which to permit access to the FTP server. To add an entry, specify the IP address and appropriate mask and select Add.

When the list is empty, access is permitted from any IP address.

Active interfaces

Select the interfaces through which client stations can access the FTP server.

To select multiple entries, hold down the shift or control key as you select each entry.

Current site files

These are the files that are currently installed on the Web server and make up the public access interface. You can edit and create text files using the built-in editor. Other files must be created offline and uploaded via FTP.

For an overview of the default site structure and control flow, see [“Public access interface control flow” \(page 403\)](#).

Add New File

Select this button to create a new text-based file on the server.

Reset to Factory Default Content

Select this button to reset the site files to factory default content. You should make a backup copy of the current content using the **Site file archive** options before restoring factory defaults.

About ASP variables

A number of ASP variables are defined for use by the public access interface pages. These variables are used to make configuration and status information available via ASP function calls, allowing for customization of Web page content. Some of the site configuration options set the values of these variables. See [“Public access interface ASP functions and variables” \(page 490\)](#).

Site file descriptions

`account.asp`

text/html

This page is launched by `subscribe.asp` when the user selects **Next**. It displays a summary of the subscription plan that was chosen and prompts for a username and password to create a new user account.

- Selecting **Cancel** launches `index.asp`.
- Selecting **Next** launches `payment.asp`.

`ads-frame.asp`

text/html

This file contains the frame content for ads when using `ads-frameset.asp`.

`ads-frameset.asp`

text/html

Page that is used to display advertisements using frames. Users see the ad in a frame and their original Web site in second frame.

Users can select the **Continue Browsing** button to return to their original Web page, or continue browsing within the frame.

ads.asp

text/html

Page that is used to display advertisements without frames. Users are redirected to this page while browsing and must select the **Continue Browsing** button to return to their original Web page.

ads.jpg

image/jpeg

This is the default advertisement that is displayed.

fail.asp

text/html

This is a generic error reporting page that is called by various other pages to present an error message.

goodbye.asp

text/html

When a user logs out (by selecting the **Logout** button on the `session.asp` page, for example), if no **goodbye-url** attribute is defined (which specifies the location of a goodbye page), the user is redirected to this page. If this page is missing, than `fail.asp` is presented.

graceful_ending.js

application/javascript

Provides a graceful ending to subscription plans that are about to expire. When a subscription plan has only 10 minutes left or reaches 80% of its transfer quota (these limits are configurable in this script), a warning appears encouraging the user to purchase another plan before their existing one expires.

index.asp

text/html

This is the Login page that users see when they are first redirected to the public access interface.

The Login page contains a single graphic element suitable for a logo or other identifying element and two fields (username and password) that enable users with an existing account to log in. Additional choices may be visible on the Login page if the following features are enabled on the **Controller >> Public access > Web content** page under **Site options**:

- Allow subscription plan purchases
- Display the Free Access option.

login_error_message.asp

text/html

Error messages and the code that is used to display them. Used by `index.asp`.

logo.gif

image/gif

Re-usable image shared by a number of pages.

payment.asp

text/html

This page is called by `account.asp` when a user selects **Next**. It displays a summary of the users subscription selection.

For the Authorize.Net payment service

- Credit card information is requested.
- Selecting **Review**, launches `review.asp`.
- Errors in payment information cause this page to be redisplayed.
- Selecting **Cancel** returns the user to the Login page (`index.asp`).

For the WorldPay payment service

- Selecting **Go to WorldPay** launches the payment processing page on the WorldPay site.
- Selecting **Cancel** returns the user to the Login page (`index.asp`).

See [WorldPay-cancel.asp/WorldPay-error.asp/WorldPay-success.asp](#).

For the PayPal payment service

- Selecting **Checkout with PayPal** redirects the user to the PayPal site.
- Selecting **Cancel** returns the user to the Login page (`index.asp`).

See [paypal-cancel.asp](#), [paypal-return.asp](#), and [paypal_error.asp](#).

paypal-cancel.asp

The user is redirected to this page if they cancel the PayPal transaction when on the PayPal site or on `paypal-return.asp`.

paypal_error.asp

In the case where PayPal detects any error, the user is redirected to this page and PayPal error messages are displayed. Error messages are defined by PayPal here:

https://cms.paypal.com/us/cgi-bin/?cmd=_render-content&content_ID=developer/e/howto/api/nvp/errorcodes

paypal-return.asp

Once a user has completed setting up payment details on the PayPal site, the PayPal server redirects the user to this page which then displays a summary of the transaction.

- Selecting **Confirm** finalizes the transaction. A request is sent to PayPal, and if approved, the user is redirected to `purchase_approved.asp`. If not approved, the user is sent to `paypal-error.asp`.
- Selecting **Cancel** redirects the user to `paypal-cancel.asp`.

prototype.js

application/javascript

Javascript library used to support AJAX for use in `session_ajax.asp` and `subscription_details.asp`.

public-ip.asp

text/html

Message page that is displayed explaining the steps a user must follow to activate a public IP address. This page is only displayed if a public IP address is assigned in the users account or account profile. See [“Assigning public IP addresses” \(page 47\)](#).

purchase_approved.asp

text/html

This page is displayed as soon as payment is approved. The user selects **Login** on this page to open `welcome.asp`.

purchase_failed.asp

text/html

This page is displayed if payment fails.

redirect.asp

text/html

This is the page that is sent when the controller intercepts a connection from a non-authenticated user. Its function is to redirect the browser to the Login page.

review.asp

text/html

This page is called by `payment.asp` and applies to Authorize.Net payments only.

It displays a summary of the users subscription selections and presents a **Pay** button. Selecting **Pay** completes the Authorize.Net transaction. If the transaction is approved, `purchase_success.asp` page is called, otherwise, `purchase_failed.asp` is called.

session.asp

text/html

This page shows usage statistics for the session, as well as the logout button that the user selects to terminate the session.

session.js

application/javascript

Included by `session.asp`. Provides smart updates for Javascript-based browsers.

session_ajax.asp

text/html

This page is specially designed for AJAX, and provides a JSON page format for use by `session.js` to provide the same content as `session.asp` but for Javascript-enabled browsers. This enables smart refresh of the session data; only changed data is updated, not the entire page, eliminating screen flickering.

`Session.asp` includes `session.js` which calls `session_ajax.asp`.

sessionwindow.js

application/javascript

Contains Javascript functions used to control opening and closing of the session page.

setfocus.js

application/javascript

Contains Javascript functions used to set the focus to the first form on a page.

style.css

text/css

Stylesheet for all public access interface Web pages.

subscribe.asp

text/html

This page is called by `index.asp` and `session.asp` if **Allow subscription plan purchases** is enabled on the **Controller >> Public access > Web content** page under **Site options**.

The page displays all defined subscription plans so that the user can choose one.

The user can select **Next** to proceed to `account.asp`, or **Cancel** in which case they are redirected to `index.asp`.

subscription_details.asp

text/html

This page is called by `session.asp`. It provides information on the subscription plan selected by a user, as well as running totals for data transfer and online time.

subscription_details.js

application/javascript

Included by **subscription_details.asp**. Provides smart updates for Javascript-based browsers.

subscription_details_ajax.asp

text/html

Included by **subscription_details.asp**. Provides smart updates for Javascript-based browsers.

This page is specially designed for AJAX, and provides a JSON page format for use by **subscription_details.js** to provide the same content as **subscription_details.asp** but for Javascript-enabled browsers. This enables smart refresh of the data; only changed data is updated, not the entire page, eliminating screen flickering.

subscription_details.asp includes **subscription_details.js** which calls **subscription_details_ajax.asp**. Also, **session.asp** includes **gracefulending.js** which calls **subscription_details_ajax.asp**.

subscription_details_window.js

application/javascript

Included by **session.asp**. Contains Javascript functions used to control opening and closing of the subscription details page.

subscription_error_message.asp

text/html

Error messages and code to display them. Used by: **subscribe.asp**, **account.asp**, **payment.asp**, **review.asp**, and **purchase_failed.asp**.

transport.asp

text/html

This page appears briefly after the login is approved and redirects the user to the local or external welcome page.

utils.js

application/javascript

Contains Javascript utility functions used by various public access pages.

welcome-back.asp

text/html

If the **Automatically reauthenticate HTML-based users for *nnn* minutes** option is enabled on the **Controller >> Public access > Access control** page under **User authentication**, this page is displayed for returning users instead of the Login page (**index.asp**).

welcome.asp

text/html

This page is called after the login process is complete if **Support a local Welcome page** is enabled on the **Controller >> Public access > Web content** page under **Site options**.

WorldPay-cancel.asp/WorldPay-error.asp/WorldPay-success.asp

text/html

These pages are retrieved by the WorldPay service during the payment process. This means that the Web server must be accessible to the WorldPay server. Generally this is done by assigning a public IP address to the Internet port. Modifications to these pages must follow WorldPay guidelines.

Configuring the public access Web server

The controller features an integrated Web server that, by default, is used to host the Web pages that make up the public access interface. Public access Web pages can also be hosted on third-party Web servers.

Web server configuration settings are defined on the **Controller >> Public access > Web server** page.

On the MSM720

The screenshot shows the 'Web server configuration' window for the MSM720 controller. It is divided into two main sections: 'Options' and 'Security'.
In the 'Options' section, there is a checkbox for 'NOC-based authentication' which is currently unchecked. Below this, the 'Ports' section has input fields for 'HTTP:' (8080) and 'HTTPS:' (8090). The 'MIME types' section has a 'Configure...' button.
In the 'Security' section, the 'Allowed addresses:' area has input fields for 'IP address:' and 'Mask:', followed by an 'Add' button. Below this is a 'Remove Selected Entry' button. The 'Active Interfaces:' section has checkboxes for 'Internet network' and 'VPN', both of which are unchecked. A 'Save' button is located at the bottom right of the window.

On all other controllers

The screenshot shows the 'Web server configuration' window for other controllers. It is divided into two main sections: 'Options' and 'Security'.
In the 'Options' section, there is a checkbox for 'NOC-based authentication' which is currently checked. Below this, the 'Ports' section has input fields for 'HTTP:' (8080) and 'HTTPS:' (8090). The 'MIME types' section has a 'Configure...' button.
In the 'Security' section, the 'Allowed addresses:' area has input fields for 'IP address:' and 'Mask:', followed by an 'Add' button. Below this is a 'Remove Selected Entry' button. The 'Active Interfaces:' section has checkboxes for 'Internet port' and 'VPN', both of which are unchecked. A 'Save' button is located at the bottom right of the window.

Options

NOC-based authentication

Enable this option to support NOC-based authentication.

NOC-based authentication must be used in conjunction with the remote login page feature. The remote login page feature enables users to be redirected to a remote Web server to log in instead of using the internal login page on the controller.

To validate user logins, a login application on the remote server must collect user login information and send it to the controller for authentication.

See “NOC authentication” (page 480) and “NOC authentication” (page 549).

Ports

Specify the port number the Web server uses for each protocol.

If you enable support for proxy settings under **Controller >> Public access > Access control > Zero configuration**, you must change the selected port to support client stations that are using proxy servers on the standard port (8080 or 8090). The following mappings are recommended:

- Map the unsecure port 8080 to port 81
- Map the secure port 8090 to port 444

Make sure that you do not remap these ports to values already in use on your network.

MIME types

MIME (Multipurpose Internet Mail Extensions) is an Internet standard that is used to describe the type of information that a message or file contains.

By default, the controller contains the definitions for a number of common MIME types. If you need to add your own definition, select **Configure**.

File Extension	MIME Type	Text Based	
default	application/octet-stream	False	
.xml	text/xml	True	
.xsl	text/xml	True	
.asp	text/html	True	
.htm	text/html	True	
.html	text/html	True	
.gif	image/gif	False	
.jpg	image/jpeg	False	
.css	text/css	True	
.txt	text/plain	True	
.png	image/png	False	🗑
.swf	application/x-shockwave-flash	False	🗑
.avi	video/x-msvideo	False	🗑
.js	application/javascript	True	🗑

[Add New MIME Type ...](#)

This page lists all MIME types that are currently defined on the Web server. A number of common MIME types are defined by default. (Some of the default definitions cannot be changed.)

Select **Add New MIME Type** to define your own MIME type.

Add/Edit MIME type ?

MIME type definition

File extension:

MIME type:

MIME type is text-based

[Cancel](#) [Save](#)

File extension

Specify the file extension that identifies this MIME type.

MIME type

Specify the content-type string that identifies this MIME-type. This is the value that must appear in an HTTP Content-type header for the controller to recognize this MIME type.

Types should be specified in the following format: `type/subtype`

For example: `text/xml`

MIME type is text-based

Enable this option if the MIME type identifies files that are text-based.

Security

Use this option to control access to the Web server.

Allowed addresses

The Web server will only accept connections from devices whose IP addresses appear in this list.

When the list is empty, authentication requests are accepted from any address.

Active interfaces

Select the interface(s) on which the controller will accept connections.

When NOC authentication is active, this is the interface on which the remote login Web server application can be reached. For more information on NOC authentication, see [“NOC authentication” \(page 480\)](#) and [“NOC authentication” \(page 549\)](#).

NOTE: Ingress interfaces configured inside VSCs (including the LAN port) always have access to the Web server when NOC-based authentication is disabled.

Managing payment services

The controller can directly interact with payment processing services service such as Authorize.NET and WorldPay, so that users can pay for network access from within their Web browser.

Payment services configuration

To configure payment services, follow this procedure:

1. Select **Controller >> Public access > Payment services**.

The screenshot shows a web interface for configuring payment services. It is titled "Payment services" and has a question mark icon in the top right corner. The interface is divided into two main panels. The left panel, titled "Service settings" with a question mark, contains three rows: "Payment method:" with a checked checkbox for "Credit card"; "Currency code:" with a text input field containing "USD" and a hint "(3 letters)"; and "Tax rate:" with a text input field containing "5.9" and a percentage sign. The right panel, titled "Authorize.Net service" with a question mark, contains three rows: "Payment URL:" with a text input field containing "https://test.authorize.net/"; "Login ID:" with an empty text input field; and "Transaction key:" with an empty text input field. At the bottom right of the interface is a "Save" button.

2. Enable **Credit card**. Specify the three-letter **Currency code** (see online help for list of codes) and **Tax rate**.
3. For Credit card payment authorization, select either `Authorize.NET` or `WorldPay`, and specify the appropriate information. Merchant accounts must be set up to use these services (www.authorize.net or www.worldpay.com).

Service settings

Payment method: Credit card

Enable this option to allow users to pay for services via credit card. The controller makes use of a third-party credit card processing service (either Authorize.NET or WorldPay) to handle credit card transactions.

Communications with the credit card service occurs via an SSL connection. In the case of Worldpay, you must purchase the appropriate certificate as required and install it on the **Controller >> Security > Certificates stores** page. The other payment methods do not require installation of a certificate.

The controller does not keep a record of the users credit card information. All information handled by the system is securely managed in accordance with the PCI DSS v1.2 standard.

The controller maintains a billing log that provides a simple audit trail of all transactions. The log supports the buffering and retransmission of up to 2000 billing records to an external billing records server. You can configure log options on the **Controller >> Public access > Billing records** page.

Currency code

Specify the three-letter code for the currency in which all charges will be calculated. See the online help for a complete list of currency codes.

Tax rate

Specify the tax rate to use when calculating sales tax for all charges.

Authorize.Net service

Payment URL

Specify the URL of the Authorize.Net server.

Login ID

Specify the login ID of the Authorize.Net account assigned to the controller.

Transaction key

Specify the transaction key for the Authorize.Net account assigned to the controller.

WorldPay service

Payment URL

Specify the URL of the WorldPay server.

Installation ID

Specify your WorldPay installation ID. This informs WorldPay to which merchant all sales will be credited.

Response password

Specify your WorldPay installation response password.

Other configuration issues

To successfully make use of the WorldPay service you must also address the following issues:

- The Internet port of the controller must be reachable by the WorldPay servers. This is required so that the WorldPay pages stored on the controller can be retrieved, and that the controller can receive an HTTP/HTTPS post with payment details. (To support HTTPS, a certificate signed by a well-known certificate authority must be installed on the controller.)
- An access list must be defined on the controller that gives users access to the WorldPay site without being authenticated. For example:
`access-list=factory,ACCEPT,tcp,*worldpay.com,all`

If different, replace *worldpay.com with whatever is configured.

- You must configure the payment response URL in your Worldpay customer account to point to the public access web server on the controller. This tells Worldpay where to post information about transactions. The format for the URL is:

https://host_name:port/goform/HtmlWorldpayPaymentResponse

Where:

- *host_name* is the name of the public access web server as defined in the X.509 (SSL) certificate installed on the controller.
- *port* is the HTTPS port number of the public access web server as defined on the **Controller >> Public access > Web server** page.

For complete configuration requirements, see the documentation on the WorldPay site.

PayPal service

Before you can configure and use the PayPal service you need to:

- Open a PayPal business account and obtain a PayPal user ID, user password, and signature.
- Become familiar with your responsibilities as a merchant.
- Obtain basic knowledge of the PayPal Express Checkout API (version 63.0 or higher) in order to successfully customize the PayPal public access web pages, which are: paypal-cancel.asp, paypal-return.asp, and paypal-error.asp. To see the contents of these pages, select **Controller >> Public access > Web server** and look in the Current site files list.

PayPal offers many different methods for deducting funds from a customer account. However, the controller only supports methods that provide immediate resolution. Any kind of deferred payment is not supported. As a result, when PayPal displays payment options to the user, only instant payment options are shown. If a users PayPal account does not support instant payment, then they will not be able to purchase services.

In order to pay for service with PayPal, users must be able to reach the PayPal server before they are authenticated. Therefore, an access list must be created on the controller to give unauthenticated users access to the PayPal server. For example, you can add the following definition to the default access list called **factory**:

```
access-list=factory,ACCEPT,tcp,*paypal.com,all
```

Add this definition by selecting **Controller >> Public access > Attributes**, and then selecting **Add New Attribute**.

User ID

Specify the user ID assigned to your PayPal business account.

User password

Specify the password assigned to your PayPal business account.

Signature

Specify the signature assigned to your PayPal business account.

Mode

- **Test:** Use this option to test your setup to make sure that everything is working properly. Requests are set to the PayPal test server at: <https://api-3t.sandbox.paypal.com/nvp>
When users select the **Checkout with PayPal** button, they are redirected to: <https://www.sandbox.paypal.com/>

For more information on using the test server, see the PayPal developer network at <https://www.x.com/community/ppx/testing>

- **Production:** Requests are set to the PayPal server at: <https://api-3t.paypal.com/nvp>
When users select the **Checkout with PayPal** button, they are redirected to: <https://www.paypal.com/>

Override default PayPal URLs

Enable this option to override the default PayPal URLs for both Test and Production modes with a custom value.

Paypal example

The following steps illustrate the typical user experience when using the new PayPal feature. To save space the pages have been cropped to remove the browser window and any banners. The name of the public access interface web page is shown for each image.

1. On the Login page, the user selects the **Subscribe to this service button** and then selects **Proceed**.

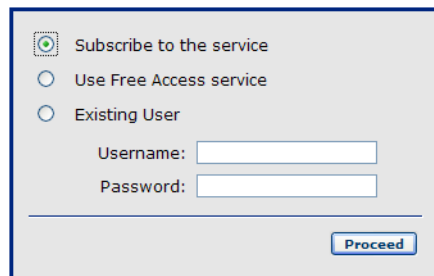

A screenshot of a login form. At the top, there are three radio buttons: "Subscribe to the service" (which is selected), "Use Free Access service", and "Existing User". Below these are two input fields: "Username:" and "Password:". At the bottom right, there is a "Proceed" button.

[Use the secure version of this form](#)

page name= *index.asp*

2. The user chooses a subscription plan and then selects **Next**.

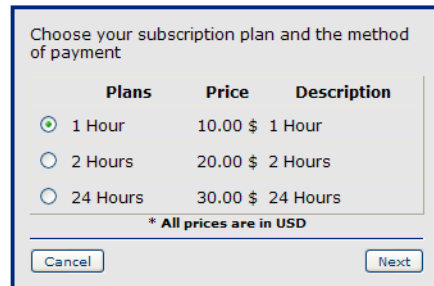

A screenshot of a subscription plan selection form. The title is "Choose your subscription plan and the method of payment". Below the title is a table with three columns: "Plans", "Price", and "Description".

Plans	Price	Description
<input checked="" type="radio"/> 1 Hour	10.00 \$	1 Hour
<input type="radio"/> 2 Hours	20.00 \$	2 Hours
<input type="radio"/> 24 Hours	30.00 \$	24 Hours

* All prices are in USD

At the bottom, there are "Cancel" and "Next" buttons.

page name= *subscribe.asp*

3. The user reviews the subscription plan information, specifies a username and password for the new account, and then selects **Next**.

Information:
 Subscription Plan: 1 Hour
 Price: 10.00\$
 Tax 0%: 0.00\$
 Total: 10.00\$
 Payment Method: PayPal
 * All prices are in USD

Account information:
 Username:
 Password:
 Confirm Password:

page name= *account.asp*

- The user selects the **Checkout with PayPal** button to pay.

Purchase Information:
 Subscription Plan: 1 Hour
 Price: 10.00 USD
 Tax 0%: 0.00 USD
 Total: 10.00 USD
 Payment Method: PayPal

Account Information:
 Username: Jane

The safer, easier way to pay

page name= *payment.asp*

- The user is redirected to the PayPal site. A banner placed at the top of the page shows the merchant's name. The user enters their PayPal username and password and selects **Log In** to sign into PayPal.

GoGo Internet

PayPal is the safer, easier way to pay 

PayPal securely processes payments for Gordon Hildebrand's Test Store. Pay with PayPal in a couple of clicks.

- You can use your credit card without exposing your card number to the seller.
- You can speed through checkout without stopping to enter your card number or address.

Sign up for a PayPal account and [continue checkout](#).

Cancel and return to [Gordon Hildebrand's Test Store](#).

Log in to PayPal

Email



Password

Forgot [email address](#) or [password](#)?

- PayPal presents billing information for the user to review. If satisfied, the user selects **Continue** to proceed. PayPal then sends the users transaction data back to the controller

GoGo Internet

Review your information

If the information below is correct, click **Continue**. You will confirm your payment on the next page.

[View PayPal policies](#) and your payment source rights.

[Add special instructions to merchant](#)

Payment Method [Enter gift certificate, reward, or discount](#)

PayPal Balance
[Change](#)

Ship to

Jane
1 Main St
San Jose, CA 95131
United States
[Change](#)

Contact Information

Jane@test.com

[Continue](#)

Cancel and return to [Gordon Hildebrand's Test Store](#).

- The user is redirected back to the controller public access interface, which presents a summary of the transaction. To continue, the user selects **Confirm**. The controller queries the PayPal server to approve the transaction.

Please Confirm

Purchase Information:

Subscription Plan: 1 Hour
Amount : 10.00 USD
Tax : 0.00 USD

Account Information:

Your Username: Jane

[Confirm](#)

[Cancel](#)

page name= *paypal-return.asp*

- If the transaction is approved, the user can login to the network by selecting **Login**.

Welcome **Jane!**

Your purchased of the subscription plan "1 Hour" was approved. You can now login into the network.

[Login](#)

purchase_approved.asp

9. The users session starts.

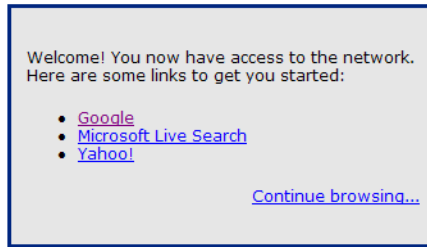

page name= *welcome.asp*

Billing record logging

The billings records logging system provides a simple audit trail of all billing transactions.

The log supports the buffering and retransmission of up to 2000 billing records to one or more external billing records servers. Log transmission occurs using HTTP/1.1 POST method with a completely customizable data format.

The system will retransmit a billing record until it is successfully acknowledged or until transmission is stopped because of too many failures.

Multiple backup servers can be assigned to a primary server to increase the probability of successfully transmitting a billing record.

To reduce the risk of billing records being lost, data can be mirrored by defining multiple primary servers. A copy of each record is sent to each primary server.

NOTE: Records are always added to the log, even when record transmission is disabled. If required, these records can be saved (exported) to a file, but cannot be transmitted to a billing server.

To configure Billing record logging, select **Controller >> Public access > Billing records**.

A screenshot of a web-based configuration interface for a "Billing records logging system". The interface is divided into several sections:

- Settings:** Contains a checkbox for "Suspend payment system when log is full of queued records" (unchecked) and a button labeled "Configure Record Formats...".
- Persistence:** Contains a checkbox for "Persistence" (unchecked), a text input field for "Save queued records every" set to "120" minutes, and a button labeled "Save Queued Records Now".
- External billing records server profiles:** A table with columns "Name", "Type", and "Server". It shows "No external billing record server profiles are defined." and a button "Add New Profile...".
- Billing records log:** Shows "Number of billing records: 0" and a dropdown menu for "Select the action to apply to all log records:" with "-- Select an Action --" and an "Apply" button.
- Table Headers:** A table with headers: "Record ID", "Transaction ID", "Transaction time", "Charge", "Billing method", and "Transmission state".
- Table Content:** Below the headers, it says "No billing record."

Settings

Suspend payment system when log is full of queued records

Use this option to halt the payment system if external billing servers are unable to receive records and the log is full of **untransmitted** records. (Records with a status of "Queued"). For more information on how the log entries are managed, see ["Billing records log" \(page 431\)](#). When this options is disabled, the oldest untransmitted record is removed from the log to make room for the new record.

Configure Record Formats

Select this button to edit the transmission, export, and acknowledgement formats for the billing records. See the online help for format descriptions.

Billing records formats ?

MIME type ?

MIME type of formats:

Transmission format ?

```
<ColubrisBillingRecord>
<RecordUID><% RECORD_UNIQUE_ID %></RecordUID>
<MSCSerial><% DEVICE_SERIAL %></MSCSerial>
<PlanID><% PLAN_ID %></PlanID>
<TransactionID><% TRANSACTION_ID %></TransactionID>
```

Export format ?

```
<% RECORD_UNIQUE_ID %>, <% DEVICE_SERIAL %>, <% PLAN_ID %>
```

Acknowledgment format ?

```
<ColubrisBillingRecordReceivingAck>
<Status><% STATUS %></Status>
<Error><% ERROR %></Error>
<Server><% SERVER %></Server>
</ColubrisBillingRecordReceivingAck>
```

Ack success value:

Persistence

Enable this option to have the controller save queued (untransmitted) records in the log to its internal flash memory so that they can be recovered in case of abnormal system shutdown (power failure, for example). See ["Billing records log" \(page 431\)](#).

Save queued records every nn minutes

Specify the interval at which the log is saved.

Save Queued Records Now

Force the log to be saved immediately.

External billing records server profiles

This list displays all configured billing records server profiles. Billing records are sent to the servers defined in this list as follows:

- A copy of the current billing record is sent to each primary server. By adding multiple primary servers you create data mirroring and reduce the risk of a record being lost.
- If a primary server fails to acknowledge the record, the controller retries. Once the retry limit is reached, the record is transmitted to any defined backup servers. Once all retries are attempted for all backup servers, the record is either skipped, or the entire process starts again.

For example, if you configure a primary server "Server A" with "Server B" as a backup, with 2 transmission attempts, the following sequence is used to transmit the billing record:

A-[Delay]-A-[Delay]-B-[Delay]-B-[Delay]-A-[Delay]-A-[Delay]-B-[Delay]-B...

To edit an existing profile, select its **Name**. To add a new profile, select **Add New Profile**. In either case you will see the Add/Edit external billing records server profile page.

The screenshot shows the 'Add/Edit external billing records server profile' configuration window. It is divided into four main sections: Settings, Security, Failover, and Fault tolerance. The Settings section includes a dropdown for 'Type' (set to 'Primary'), a text field for 'Profile name', a text field for 'Hostname/IP address', a text field for 'Port' (set to 80), a text field for 'URL', and a text field for 'Transmission timeout' (set to 10 seconds). The Security section includes a 'Secret key' text field, a checkbox for 'Use HTTPs', a checked checkbox for 'Validate server certificate', a checkbox for 'Use HTTP authentication', a 'Username' text field, and a 'Password' text field. The Failover section includes a diagram with two boxes: 'Use these backup servers' and 'Available backup servers', with arrows indicating assignment. Below the diagram are text fields for 'Retries per server' (set to 3) and 'Delay between retries' (set to 3 seconds). The Fault tolerance section includes a selected radio button for 'Retransmit until successful' and an unselected radio button for 'Stop after' followed by a text field for 'failed retransmissions'. At the bottom of the window are 'Cancel' and 'Save' buttons.

Settings

Type

- **Primary:** Defines a primary server. The controller sends a copy of each billing record to all primary servers. See [“Record transmission overview” \(page 431\)](#).
- **Backup:** Defines a backup server. Backup servers can be assigned to act as a backup to a primary server by using the **Failover** box.

Profile name

Specify a name to identify the server profile.

Hostname/IP address

IP address or hostname of the server.

Port

Port on which to send the HTTP post.

URL

URL to which the HTTP post will be sent.

Transmission timeout

Amount of time that the controller waits for an HTTP response for a transmitted record. If the response is not received within this period, this is considered as a failed transmission.

Failover

Use this box to define one or more backup server profiles for the current primary server profile.

Use these backup servers

Lists all backup server profiles for this primary server profile. Backup profiles are used in the order that they appear in the list.

Available backup servers

Lists all server profiles of type backup.

Retries per server

Number of times that a record will be retransmitted before the next profile is tried.

NOTE: This parameter also sets the number of retries on the primary.

Delay between retries

Amount of time to wait between retransmitting a record.

Security

Encryption and authentication can be used to increase the transmission security of billing records. HTTP authentication and secure HTTP using SSLv3 are supported. Also, to make sure that a billing record has not been altered, a secret key, shared between the billing server and the controller, can be defined and used to produce a cryptographic signature of the billing record.

Secret key

Specify the secret key that will be used to generate an encryption signature using HMAC-SHA-1. The signature is generated using the entire contents of the billing record. (The signature field is empty when the signature is calculated.)

Use HTTPS

When enabled, secure HTTP using SSLv3 is used to transmit records to all servers.

Validate server certificate

When enabled, the controller will validate the external billing server certificate. For this to be successful, you must install the billing server CA certificate in the Trusted CA certificate store on the **Security > Certificate stores** page.

Use HTTP authentication

Enable this option if the billing server requires a username and password.

Fault tolerance

Fault tolerance settings control how many times each billing record is retransmitted.

Retransmit until successful

When enabled, the controller will never skip a record due to transmission failure. Retransmission is continuously retried on the primary server and all backup servers until successful.

Enabling this option may cause log entries to be lost if a record fails to be transmitted before the log wraps around. To avoid losing records, enable the **Suspend operation of payment system when log is full** option under **Log settings** on the **Controller >> Public access > Billing records** page.

Stop after failed nnn retransmissions

Select this option to have the controller stop retransmitting a record when the total number of retransmissions on all servers (primary and backup) exceeds the specified number.

When this occurs the record is flagged as **Transmission Failed** in the log.

Record transmission overview

Transmission of a billing record occurs as follows:

- Billing record is transmitted to the primary server.
- If the primary server does not send an HTTP reply within the **Transmission timeout**, then the transmission is considered to have failed. If a response is received, but the status field does not match the value of **Ack success value**, then the transmission is considered to have failed.
- Failed transmissions are retried on the primary server until the **Retries per server** limit is met, after which each backup server is tried in order. Once all backups are tried, the sequence resumes again with the primary server.
- Retransmissions only stop if the selected condition under **Fault tolerance** is met: either the record is successfully transmitted or the total number of retries on all servers passes a predetermined limit.

NOTE: A billing record is considered to be successfully transmitted only when it has been successfully transmitted to **every primary server** (or one of its backups).

Billing records log

This table displays the contents of the billing records log. The log can hold up to 2000 records. When full, records are deleted in the following order:

1. Records that have been successfully transmitted.
2. Records that do not have to be transmitted, because transmission is disabled.
3. Records for which transmission has failed.

If transmissions to remote billing server(s) is interrupted, the log can become full of untransmitted records only. (Records with status set to "Queued".) What happens next is controlled by the **Suspend payment system when log is full of queued records** when log is full setting under **Settings**.

- If enabled, payment services are suspended.
- If disabled, the oldest queued record is removed.

Number of billing records

Lists the total number of billing records in the log.

Select the action to apply to all log records

- **Clear log:** Delete all records in the log.
- **Save log:** Save the log to a file using the export format defined by selecting **Controller >> Public access > Billing records > Configure Records Format**.
- **Retransmit failed records:** Force the retransmission of records that have transmission state set to **Transmission Failed**. This starts the complete transmit cycle all over again for the record.
- **Cancel current transmission:** Terminates the record transmission that is currently in progress.

Table

Record ID

Unique number that identifies each record.

Transaction ID

Credit card transaction ID generated by the credit card service.

Transaction time

Date and time of the transaction.

Charge

Amount charged on the transaction.

Billing method

Identifies the billing method:

- CC_WORLDPAY
- CC_AUTHORIZE_NET
- CC_PAYPAL

Transmission state

- **Transmitting:** The record is being transmitted.
- **Queued:** The record is queued for transmission.
- **Transmission Disabled:** Transmission of the record was disabled. Once records fall into this category they cannot be retransmitted.
- **Successful:** The record was successfully transmitted and acknowledged by all primary servers (or their backups).
- **Transmission Failed:** The record was not transmitted successfully and retransmission attempts have stopped due to the setting for **Fault tolerance** in the billing records server profile (**Controller >> Public access > Billing records > External billing records server profiles**).

Location-aware authentication

This feature enables you to control logins to the public access network based on the wireless access point with which a user is associated. Once authenticated, this feature is also used to monitor and control roaming to other access points in the network.

How it works

Location-aware is automatically enabled when a VSC is set to **provide access control**. When enabled, the location-aware feature causes the controller to return location-specific information for RADIUS-authenticated users. This information is returned:

- When the user logs in
- Each time the user roams to a new access point or switches SSIDs on the same access point (which causes the user to be re-authenticated).

NOTE: Due to security constraints in 802.1X client software, users cannot automatically be re-authenticated when roaming to a new access point. Therefore, location-aware information cannot be returned when these users roam.

Returned information

The controller can return the following attributes in the RADIUS access request for all user authentications (whether initial login or re-authentication due to roaming):

- Called-station-ID (Standard RADIUS attribute)
- HP-specific attribute: SSID
- HP-specific attribute: GROUP

NOTE: When re-authenticating users, the returned RADIUS attribute Service-Type is set to 8744 (decimal).

Called-Station-ID value

By default, this is the MAC address of the wireless port (radio) to which the user is associated. This is the MAC address of the **wvlan0** or **wvlan1** interface in IEEE format as displayed by **Tools > System Tools > Interface info**.

If required, the controller can return other values for this attribute by setting the **Called-Station-Id content** on a per-VSC basis. The other available options are:

- **SSID:** SSID of the access point with which the user is associated.
- **Group:** Group name of the access point with which the user is associated.
- **macaddress:** Returns the MAC address of the wireless port (radio) the user is associated with. This is the MAC address of the **wvlan0** or **wvlan1** interface as shown by **Controller >> Tools > System Tools > Interface info**.

If the user is connected via a wired connection, the value returned is the MAC address of the controller wireless/LAN port. To use the MAC address of the Internet port, you must edit the config file and change the setting of **radius-called-station-id-port** to **WAN** in the `<ACCESS-CONTROLLER>` section.

- **macaddress:ssid:** The MAC address of the wireless APs radio, followed by a colon, followed by the SSID configured on this VSC.

HP-specific attribute: SSID

The SSID of the access point with which the user is associated (wireless only).

HP-specific attribute: GROUP

The group name of the access point with which the user is associated (wireless only).

Example

Consider the following topology for a fictional small hotel. The restaurant and lounge are available to all hotel users who subscribe to the wireless service. However, the conference room is available only to a specific group of guests who book it in advance.

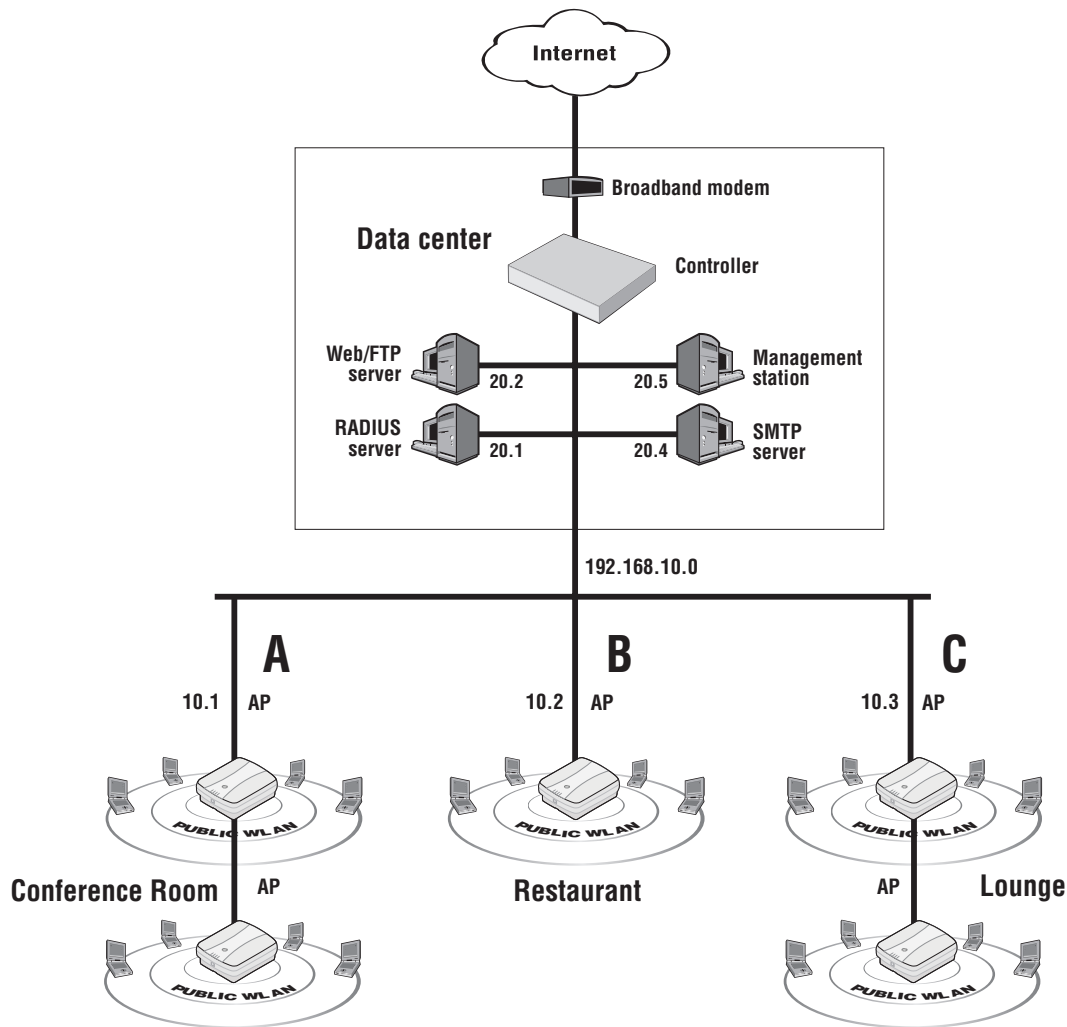

In this example, the access points in each area are assigned the following unique group names:

- conference_room
- restaurant
- lounge

When a user logs in, server-side code can be used to determine the access point they are associated with by inspecting the Called-Station-ID. Then, using users account information, access can either be granted or denied.

Security

The controller accepts location-aware information only from MSM APs that have a matching shared secret to its own.

21 Working with RADIUS attributes

Introduction

RADIUS attributes can be used to customize a wide range of configuration settings on the controller. This includes defining configuration settings for the public access interface, customizing the settings of access-controlled user accounts, or configuring credentials for the administrative accounts that are used to manage/operate the controller.

Attributes can be defined both locally on the controller or retrieved from a third-party RADIUS server. In certain cases, values can be defined locally and then overwritten by values retrieved from a RADIUS server. This allows, for example, default values on the controller to be dynamically updated on a per-user basis.

This chapter splits the supported RADIUS attributes into three categories:

Category	Description	For information, see...
Controller attributes	Used to customize the operation of the public access interface (creating access lists for walled gardens, for example), and also to define default values that are applied to all user accounts.	<ul style="list-style-type: none">• “Controller attributes overview” (page 435)• “Colubris AV-Pair - Site attribute values” (page 458)
User attributes	Used to customize the settings of individual access-controlled user accounts.	<ul style="list-style-type: none">• “User attributes” (page 443)• “Colubris AV-Pair - User attribute values” (page 484)
Administrator attributes	Used to define login credentials for administrative users (managers and operators).	<ul style="list-style-type: none">• “Administrator attributes” (page 457)• “Colubris AV-Pair - Administrator attribute values” (page 489)

Controller attributes overview

The controller provides support for a number of standard RADIUS attributes, including those for authentication and accounting. See “Controller attribute definitions” (page 438) for a list of these attributes and a brief definition. For detailed information on these attributes, refer to RFC2865, or the documentation that came with your RADIUS server.

The controller also supports several vendor-specific attributes, including the special HP attribute (known as the *site attribute*) that is used to customize the behavior of the public access interface and define global default values for user accounts. To find out more about the site attribute, see the following section.

Customizing the public access interface using the site attribute

HP ProCurve has defined a vendor-specific RADIUS attribute to support configuration of the public access interface and user accounts. This attribute conforms to RADIUS RFC 2865 and is called the **Colubris AV-Pair**.

Multiple instances of the Colubris AV-Pair attribute can be defined on the controller, each with a different **AV-Pair value**. For a complete list of all supported AV-Pair values, see “Colubris AV-Pair - Site attribute values” (page 458).

In order for a third-party RADIUS server to support the Colubris AV-Pair attribute you need to define it as described under **Colubris AV-Pair**.

NOTE: The Colubris AV-Pair attribute can be used to define settings on the controller and for users and administrators. This section discusses controller settings only.

- ① **IMPORTANT:** The documentation for this product frequently uses the terms site attributes and user attributes to refer to the Colubris AV-Pair attribute values depending on whether the AV-Pair attribute values are set with a value that applies to the public access site or to an individual user.

Defining and retrieving site attributes

Site attributes can be retrieved from a third-party RADIUS server or specified directly on the controller. In both cases, configuration settings are defined on the **Controller >> Public access > Attributes** page.

ⓘ Any change to the local site configuration will only get applied at the next reauthentication.

Retrieval of attributes

Retrieve attributes using RADIUS

RADIUS profile: Default RADIUS Profile Name

RADIUS username:

RADIUS password:

Confirm RADIUS password:

Accounting

Retrieval settings

Retrieved attributes override configured attributes

Retrieval interval: 720 minutes

Last retrieved: 0:00:22 ago

Retrieve Now

Save

Configured attributes

Attribute	Value	Action
ACCESS-LIST	factory,ACCEPT,all,*procurve.com,a...	↑ ↓ 🗑
ACCESS-LIST	factory,ACCEPT,all,*hp-ww.com,all	↑ ↓ 🗑
ACCESS-LIST	factory,ACCEPT,all,*windowsupdate....	↑ ↓ 🗑
USE-ACCESS-LIST	factory	🗑
DEFAULT-USER-IDLE-TIMEOUT	22	🗑
DEFAULT-USER-SESSION-TIMEOUT	100	🗑
VSA-WISPR-ACCESS-PROCEDURE	1.0	🗑

Add New Attribute...

Retrieving site attributes from a RADIUS server

To retrieve attributes from a RADIUS server, enable the **Retrieve attributes using RADIUS** option. To use this option, you must also configure a RADIUS profile (see [“Using a third-party RADIUS server”](#) (page 364)) and define an account for the controller on the appropriate RADIUS server. This account must contain all site attributes that you want to retrieve. For a complete list of all supported site attributes and their syntax, see [“Colubris AV-Pair - Site attribute values”](#) (page 458).

After the controller is authenticated by the RADIUS server it automatically retrieves the site attributes you defined in the controller's RADIUS account. The retrieved attributes are then combined with the attributes defined in the **Configured attributes** list (if any) to build the complete list of attributes that are active on the controller. If the same attribute is defined on both the RADIUS server and in the **Configured attributes** list, the setting of **Retrieved attributes override configured attributes** determines which definition is used.

NOTE: A maximum of 256 attributes can be active at any one time (including both the RADIUS and the **Configured attributes** list).

The maximum attribute size that the controller can receive in a single RADIUS request is 4096 bytes. However, some networks may limit RADIUS request size to around 1500 bytes because they discard UDP fragments.

Configure the **Retrieve attributes using RADIUS** options as follows:

- **RADIUS profile:** Select a RADIUS profile. The profile is used to establish the connection to a RADIUS server. RADIUS profiles are defined by selecting **Controller >> Authentication > RADIUS profiles**. For details, see [“Using a third-party RADIUS server” \(page 364\)](#).
- **RADIUS username:** Specify the username of the RADIUS account assigned to the controller.
- **RADIUS password / Confirm password:** Specify the password of the RADIUS account assigned to the controller.
- **Accounting:** Enable this option to have the controller generate a RADIUS accounting request ON/OFF each time its authentication state changes.
- **Retrieved attributes override configured attributes:** Enable this option to have attributes retrieved from the RADIUS server overwrite settings defined in the **Configured attributes** table.
- **Retrieval interval:** Specify the number of minutes between attribute retrievals. The controller retrieves attributes from its RADIUS account each time this interval expires.

To avoid potential service interruptions that may occur when new attributes are activated by the controller, it is strongly recommended that you use a large interval (12 hours or more).

You can override the value configured on this page by using the RADIUS attribute **Session-timeout**, which enables the following strategy: Configure **Retrieval interval** to a small value (10 to 20 minutes) and set the RADIUS attribute **Session-timeout** to override it with a large value (12 hours) when authentication is successful. Since the **Retrieval interval** is also respected for Access Reject packets, this configuration results in a short reauthentication interval in the case of failure, and a long one in the case of success.

- **Last retrieved:** Shows the amount of time that has passed since the controller last retrieved attributes.
- **Retrieve Now:** Select to force the controller to contact the RADIUS server and retrieve attributes.

Defining site attributes directly on the controller

Site attributes can be defined directly on the controller eliminating the need to use a RADIUS server. If needed, both methods can be used at the same time. In this case, the retrieved attributes are combined with those attributes defined in the **Configured attributes** list to build the complete list of attributes that are active on the controller. If the same attribute is defined on both the RADIUS server and in the **Configured attributes** list, the setting of **Retrieved attributes override configured attributes** determines which definition is used.

To add a new attribute:

1. Select **Add New Attribute**. The **Public access attribute** page opens.
2. Under **Name**, select an AV-Pair value, as shown in the following figure.

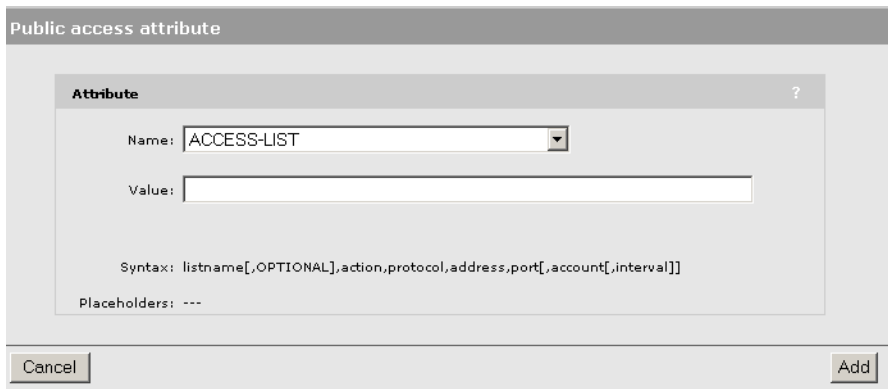

3. Once you select a **Name**, information appears regarding the correct syntax to specify under **Value**. Use the correct syntax to specify the desired **Value**.
For a complete list of all supported site attributes and their syntax, see [“Colubris AV-Pair - Site attribute values” \(page 458\)](#), or consult the online help.
4. Select **Add**.

Controller attribute definitions

The following table lists all RADIUS attributes supported by the controller. A brief description of each attribute follows the table. For detailed information, refer to RFC2865, or the documentation that came with your RADIUS server.

Access Request

- [Acct-Session-Id](#)
- [Called-Station-Id](#)
- [Calling-Station-Id](#)
- [CHAP-Challenge](#)
- [CHAP-Password](#)
- [Connect-Info](#)
- [EAP-Message](#)
- [Framed-IP-Address](#)
- [Framed-MTU](#)
- [NAS-Identifier](#)
- [NAS-IP-Address](#)
- [NAS-Port](#)
- [NAS-Port-Type](#)
- [Message-Authenticator](#)
- [Service-Type](#)
- [State](#)
- [User-Name](#)
- [User-Password](#)

Access Accept

- [Class](#)
- [EAP-Message](#)
- [Session-Timeout](#)
- [Vendor-specific \(Colubris\)](#)
 - [Colubris AV-Pair](#)

Access Reject

No attributes are supported.

Access Challenge

No attributes are supported.

Accounting Request

- [Acct-Authentic](#)
- [Acct-Delay-Time](#)
- [Acct-Event-Timestamp](#)
- [Acct-Session-Id](#)
- [Acct-Status-Type](#)
- [Called-Station-Id](#)

- | | |
|--|---|
| <ul style="list-style-type: none"> • Vendor-specific (Microsoft) <ul style="list-style-type: none"> ◦ MSCHAP-Challenge ◦ MSCHAP-Response ◦ MSCHAPv2-Response • Vendor-specific (WISPr) <ul style="list-style-type: none"> ◦ Location-Name ◦ Location-ID ◦ Logoff-url | <ul style="list-style-type: none"> • Calling-Station-Id • Class • Framed-IP-Address • NAS-Identifier • NAS-IP-Address • NAS-Port • NAS-Port-Type • User-Name <p>Accounting Response
No attributes are supported.</p> |
|--|---|

In the attribute descriptions, a *string* is defined as 1 to 253 characters.

Access request

Acct-Session-Id

(32-bit unsigned integer)

Random value generated per authentication by the controller.

Called-Station-Id

(string)

By default, this is set to the MAC address of the controller wireless/LAN port in IEEE format. For example: 00-02-03-5E-32-1A. To use the MAC address of the Internet port, you must edit the config file and change the setting of **radius-called-station-id-port** to **WAN** in the <ACCESS-CONTROLLER> section.

Calling-Station-Id

(string)

The MAC address of the controller LAN port in IEEE format. For example: 00-02-03-5E-32-1A.

CHAP-Challenge

(string)

Randomly generated by the product. As defined in RFC 2865. Only present when the authentication method for the RADIUS profile is set to CHAP. Length = 19 bytes.

CHAP-Password

(string)

The password assigned to the controller on the **Public access > Attributes** page. Encoded as defined in RFC 2865. Only present when the authentication method for the RADIUS profile is set to CHAP.

Connect-Info

(string)

The string "HTTPS".

EAP-Message

As defined in RFC 2869. Only present when the authentication method for the RADIUS profile is set to EAP-MD5.

Framed-IP-Address

(32-bit unsigned integer)

IP Address of the controller LAN port.

Framed-MTU

(32-bit unsigned integer)

Hard-coded to 1496 (802.1X). Hard-coded value of 1496. The value is always four bytes lower than the wireless MTU maximum which is 1500 bytes in order to support IEEE802dot1x authentication.

NAS-Identifier

(string)

The NAS ID set on the **Controller >> Authentication > RADIUS profiles > Add New Profile** page for the RADIUS profile being used.

NAS-IP-Address

(32-bit unsigned integer)

The IP address of the port the controller is using to communicate with the RADIUS server.

NAS-Port

(32-bit unsigned integer)

Always 0.

NAS-Port-Type

(32-bit unsigned integer)

Always set to 19, which represents WIRELESS_802_11.

Message-Authenticator

(string)

As defined in RFC 2869. Always present even when not doing an EAP authentication. length = 16 bytes.

Service-Type

(32-bit unsigned integer)

RADIUS service type.

State

(string)

As defined in RFC 2865.

User-Name

(string)

The RADIUS username assigned to the controller on the **Public access > Attributes** page.

User-Password

(string)

The password assigned to the controller on the **Public access > Attributes** page. Encoded as defined in RFC 2865. Only present when the authentication method for the RADIUS profile is set to PAP.

Vendor-specific (Microsoft)

HP ProCurve supports the following Microsoft vendor-specific attributes.

MSCHAP-Challenge

(string)

As defined in RFC 2433. Only present when the authentication method for the RADIUS profile is set to MSCHAPv1 or MSCHAPv2. Length = 8 bytes.

MSCHAP-Response

As defined in RFC 2433. Only present when the authentication method for the RADIUS profile is set to MSCHAPv1. Length = 49 bytes.

MSCHAPv2-Response

(string)

As defined in RFC 2759. Only present when the authentication method for the RADIUS profile is set to MSCHAPv2. Length = 49 bytes.

Vendor-specific (WISPr)

HP ProCurve supports the following Wi-Fi Alliance vendor-specific attributes.

Location-Name

The WISPr location name assigned to the controller.

- SMI network management private enterprise code = 14122
- Vendor-specific attribute type number = 2
- Attribute type: A string in the format: *wispr-location-name=location_name*

Location-ID

The WISPr location identifier assigned to the controller.

- SMI network management private enterprise code = 14122
- Vendor-specific attribute type number = 1
- Attribute type: A string in the format: *wispr-location-id=location_id*

Logoff-url

The WISPr log-off URL that will be used.

- SMI network management private enterprise code = 14122
- Vendor-specific attribute type number = 3
- Attribute type: A string in the format: *wispr-logoff-url=URL*

Access accept

Class

As defined in RFC 2865. Multiple instances are supported.

EAP-Message

(string)

Only supported when authentication is EAP-MD5. Note that the content will not be read as the RADIUS Access Accept overrides whatever indication is contained inside this packet.

Session-Timeout

(32-bit unsigned integer)

The controller will retrieve RADIUS attributes when this timer expires. Omitting this attribute or specifying 0 disables the feature. (Note that this is configurable directly on the controller by setting **Public access > Attributes > Retrieval interval**.)

Vendor-specific (Colubris)

Colubris AV-Pair

(string)

HP ProCurve has defined this vendor-specific attribute to support configuration of special features on the controller, such as the customization of the public access interface and global user session settings. This attribute conforms to RADIUS RFC 2865. You may need to define this attribute on your RADIUS server (if it is not already present) using the following values:

- SMI network management private enterprise code = 8744
- Vendor-specific attribute type number = 0
- Attribute type: A string in the following format *<keyword>=<value>*

Multiple instances of the Colubris AV-pair can be defined in a RADIUS account to configure a variety of settings. For a complete list of all supported attributes, see [“Colubris AV-Pair - Site attribute values”](#) (page 458).

Access reject

No attributes are supported.

Access challenge

No attributes are supported.

Accounting request**Acct-Authentic**

(32-bit unsigned integer)

Always set to 1 which means RADIUS.

Acct-Delay-Time

(32-bit unsigned integer)

As defined in RFC 2869.

Acct-Event-Timestamp

(32-bit unsigned integer)

As defined in RFC 2869.

Acct-Session-Id

(32-bit unsigned integer)

Random value generated by the controller.

Acct-Status-Type

(32-bit unsigned integer)

Supported values are: Accounting-On (7) and Accounting-Off (8).

Called-Station-Id

(string)

The MAC address of the controller LAN port in IEEE format. For example: 00-02-03-5E-32-1A.

Calling-Station-Id

(string)

The MAC address of the controller LAN port in IEEE format. For example: 00-02-03-5E-32-1A.

Class

(string)

As defined in RFC 2865. Multiple instances are supported.

Framed-IP-Address

(32-bit unsigned integer)

IP Address of the controller LAN port.

NAS-Identifier

(string)

The NAS ID for the RADIUS profile being used.

NAS-Ip-Address

(32-bit unsigned integer)

The IP address of the port the controller is using to communicate with the RADIUS server.

NAS-Port

(32-bit unsigned integer)

Always 0.

NAS-Port-Type

(32-bit unsigned integer)

Always set to 19, which represents WIRELESS_802_11.

User-Name

(string)

The RADIUS username assigned to the controller on the **Public access > Attributes** page.

Accounting response

No attributes are supported.

User attributes

The controller provides support for a number of standard RADIUS user attributes, including those for authentication and accounting. See [“User attribute definitions” \(page 448\)](#) for a list of these attributes and a brief definition. For detailed information on these attributes, refer to the documentation that came with your RADIUS server.

The controller also supports several vendor-specific attributes, including the special HP attribute (known as the *user attribute*) that is used to customize the behavior of the public access interface and define values for user accounts. To find out more about the user attribute, see the following section.

Customizing user accounts with the user attribute

HP ProCurve has defined a vendor-specific RADIUS attribute to support configuration of the public access interface and user accounts. This attribute conforms to RADIUS RFC 2865 and is called the **Colubris AV-Pair**.

Multiple instances of the Colubris AV-Pair attribute can be defined for each user, each with a different **AV-Pair value**. For a complete list of all supported AV-Pair values, see [“Colubris AV-Pair - User attribute values” \(page 484\)](#).

In order for a third-party RADIUS server to support the Colubris AV-Pair attribute you need to define it as described under [Colubris AV-Pair](#).

NOTE: The Colubris AV-Pair attribute can be used to define settings on the controller and for users and administrators. This section discusses user settings only.

- ① **IMPORTANT:** The documentation for this product frequently uses the terms site attributes and user attributes to refer to the Colubris AV-Pair attribute values depending on whether the AV-Pair attribute values are set with a value that applies to the public access site or to an individual user.
-

Defining and retrieving user attributes

User attributes can be retrieved from a third-party RADIUS server or specified directly on the controller in user account profiles.

Defining attributes locally in user accounts

If you are using the local user accounts to authenticate users, then you can define account attributes locally via account profiles.

Each user account can be associated with one or more account profiles. The attributes that are set in each profile are combined in the account to produce the full list of active attributes.

If you are working with access-controlled user accounts, additional attributes can also be defined via the **Default AC** profile.

The best way to understand how all this works is to look at an example.

Example

In this example, two user profiles (called **Employee** and **Guest**) are defined on the **Controller >> Users > Account profiles** page. The settings for each profile are shown below.

Employee profile

Sets the attributes that will be used to define employee accounts.

Add/Edit account profile

General

Profile name:

Access-controlled profile

Egress interface

Egress VLAN:

Access-control features

VPN one-to-one-NAT: On Off

Legal interception: On Off

SMTP redirection:

Public IP address: On Off

Access list

List name:

Session time attributes

Reauthentication period: seconds

Termination action:

Idle timeout: seconds

Accounting interim interval: seconds

QoS parameters

Max output rate: Kbps

Max input rate: Kbps

Bandwidth level:

Station presence queries

Polling ARP interval: seconds

Polling max ARP count:

Advertising

Display advertisements: On Off

Custom attributes

Name	Type	Value	Move	Delete
No custom attributes are defined.				

Guest profile

Sets the attributes that will be used to define guest accounts.

Add/Edit account profile

General ?

Profile name:

Access-controlled profile

Egress interface ?

Egress VLAN:

Access-control features ?

VPN one-to-one-NAT: On Off

Legal interception: On Off

SMTP redirection:

Public IP address: On Off

Access list ?

List name:

Session time attributes ?

Reauthentication period: *seconds*

Termination action:

Idle timeout: *seconds*

Accounting interim interval: *seconds*

QoS parameters ?

Max output rate: *Kbps*

Max input rate: *Kbps*

Bandwidth level:

Station presence queries ?

Polling ARP interval: *seconds*

Polling max ARP count:

Advertising ?

Display advertisements: On Off

Custom attributes ?

Name	Type	Value	Move	Delete
No custom attributes are defined.				

Once account profiles have been defined, user accounts can be created.

The following sample page shows the initial configuration of a user account for an employee named **Bill**. Notice that before any account profile is assigned, the **Effective attributes** box shows a couple of active attributes: **Idle timeout**, and **Session timeout**.

Add/Edit user account

General ?

User name:

Password:

Confirm password:

Active

Access-controlled account

Account removal ?

Delete this account when

Invalid/expired for hours

Inactive for hours

Validity ?

Subscription plan:

Valid until:
(mm/dd/yyyy)

Always valid

Options ?

Max concurrent sessions:

Chargeable User Identity:

Idle timeout: seconds

Reauthentication period: seconds

VSC usage ?

Available VSCs:

Restrict this account to these VSCs:

Account profiles ?

Available profiles:

Set account attributes using these profiles:

Effective attributes ?

Attributes from the [default AC profile](#) are always applied.

Session timeout	100
Idle timeout	22

These attributes come from the **Default AC** profile. Attributes from this profile are automatically assigned to all access-controlled user accounts. To customize the attributes for the **Default AC** profile you need to select **Controller >> Public access > Attributes**. (The default AC profile cannot be edited via the **Controller >> Users > Account profiles** page.) See [“About the Default AC profile”](#) (page 351).

To complete the configuration of Bills account, the **Employee** account profile is assigned, which adds additional attributes to the **Effective attributes** list.

Retrieving attributes from a RADIUS server

When you are using a RADIUS server to authenticate users, attributes can be set in individual user accounts to define the same settings that are available via the local user profiles. These settings are accomplished by adding both standard RADIUS attributes (“[User attribute definitions](#)” (page 448)) and one or more instances of the Colubris AV-Pair (user) attribute (“[Colubris AV-Pair - User attribute values](#)” (page 484)) to the appropriate RADIUS user accounts.

PCM IDM support

PCM is a network management solution for managing HP devices. HP Identity Driven Manager (IDM) is a plug-in to PCM Plus that enables dynamic provisioning of network security and performance settings based on user, device, location, time, and endpoint posture.

IDM can be used to define settings in a users RADIUS account that the controller will retrieve when the user is authenticated, and then apply to the users wireless session. The following PCM settings are supported.

PCM setting	Description	Supported on VSCs that are ...
Tagged VLAN (The Untagged VLAN setting is not supported.)	Specifies a VLAN number only. Names are not supported.	Access controlled and Non-access-controlled
QoS	Sets the bandwidth level for the users account. PCM numerical values are	Access controlled and Non-access-controlled

PCM setting	Description	Supported on VSCs that are ...
	mapped to the user account as follows: 6, 7 = VERY-HIGH 4, 5 = HIGH 0, 2 = NORMAL 1, 3 = LOW	Requires that the Bandwidth control feature is enabled on the controller (Controller >> Network > Bandwidth control) when access-controlled VSCs are used.
Ingress/Egress rate limit	Sets the users ingress and egress data rates in bytes.	Access controlled
Network resources access rule	Sets a custom access control list for the user.	Access controlled

Important

When using PCM to configure settings in a user's RADIUS account, you should **not** use Colubris AV-Pair values to define other settings in the same account. Standard RADIUS attributes can be used however.

User attribute definitions

The following attributes are supported for user accounts.

Access Request

- Acct-Session-Id
- Called-Station-Id
- Calling-Station-Id
- CHAP-Challenge
- CHAP-Password
- Chargeable User Identity (CUI)
- Connect-Info
- EAP-Message
- Framed-IP-Address
- Framed-MTU
- NAS-Identifier

Access Accept

- Acct-Interim-Interval
- Chargeable User Identity (CUI)
- Class
- EAP-Message
- Idle-Timeout
- Reply-Message
- Session-Timeout
- Termination-Action
- Tunnel-Medium-Type
- Tunnel-Private-Group-ID
- Tunnel-Type

Accounting Request

- Acct-Authentic
- Acct-Delay-Time
- Acct-Event-Timestamp
- Acct-Session-Id
- Acct-Status-Type
- Calling-Station-Id
- Called-Station-Id
- Chargeable User Identity (CUI)
- Class
- Framed-IP-Address
- NAS-Identifier

<ul style="list-style-type: none"> • NAS-Ip-Address • NAS-Port • NAS-Port-Type • Message-Authenticator • Service-Type • State • User-Name • User-Password • Vendor-specific (Microsoft) <ul style="list-style-type: none"> ◦ MSCHAP-Challenge ◦ MSCHAP-Response ◦ MSCHAPv2-Response • Vendor-specific (WISPr) <ul style="list-style-type: none"> ◦ Location-Name ◦ Location-ID ◦ Logoff-url 	<ul style="list-style-type: none"> • Vendor-specific (Microsoft) <ul style="list-style-type: none"> ◦ MS-MPPE-Recv-Key ◦ MS-MPPE-Send-Key • Vendor-specific (Colubris) <ul style="list-style-type: none"> ◦ Colubris AV-Pair ◦ Colubris-Intercept <p>Access Reject</p> <ul style="list-style-type: none"> • VSC • Band <ul style="list-style-type: none"> ◦ MSCHAP-Error • Wireless Mode <p>Access Challenge</p> <ul style="list-style-type: none"> • EAP-Message • State <p>Accounting Response</p> <p>No attributes are supported.</p>	<ul style="list-style-type: none"> • NAS-Ip-Address • NAS-Port • NAS-Port-Type • User-Name • Vendor-specific (WISPr) <ul style="list-style-type: none"> ◦ Location-Name ◦ Location-ID ◦ Logoff-url • Acct-Session-Time • Acct-Input-Gigawords • Acct-Input-Octets • Acct-Input-Packets • Acct-Output-Gigawords • Acct-Output-Octets • Acct-Output-Packets • Acct-Terminate-Cause
---	--	---

Access request

Acct-Session-Id

(32-bit unsigned integer) Random value generated per authentication by the controller.

Called-Station-Id

(string)

By default, this is set to the MAC address of the controller wireless/LAN port in IEEE format. For example: 00-02-03-5E-32-1A. To use the MAC address of the Internet port, you must edit the config file and change the setting of **radius-called-station-id-port** to **WAN** in the <ACCESS-CONTROLLER> section. If location-aware authentication is enabled for the VSC the user is logged into, then this value is defined by the VSC.

Calling-Station-Id

(string)

The MAC address of the users station in IEEE format. For example: 00-02-03-5E-32-1A.

CHAP-Challenge

(string)

Randomly generated. As defined in RFC 2865. Only present when the authentication method for the RADIUS profile is set to CHAP. Length = 19 bytes.

CHAP-Password

(string)

The users password. Encoded as defined in RFC 2865. Only present when the authentication method for the RADIUS profile is set to CHAP.

Chargeable User Identity (CUI)

(string)

As defined in RFC-4372. The CUI is used to associate a unique identifier with a user so that the user can be identified (for billing, authentication or other purposes) when roaming outside of their home network.

Connect-Info

(string)

The string "HTTPS" or "IEEE802.1X".

EAP-Message

(string)

As defined in RFC 2869. Only present when the authentication method for the RADIUS profile is set to EAP-MD5.

Framed-IP-Address

(32-bit unsigned integer)

IP Address as configured on the client station (if known by the controller).

Framed-MTU

(32-bit unsigned integer)

Hard-coded value of 1496. The value is always four bytes lower than the wireless MTU maximum which is 1500 bytes in order to support IEEE802dot1x authentication.

NAS-Identifier

(string)

The NAS ID set on the **Controller >> Authentication > RADIUS profiles > Add New Profile** page for the RADIUS profile being used.

NAS-IP-Address

(32-bit unsigned integer)

The IP address of the port the controller is using to communicate with the RADIUS server.

NAS-Port

(32-bit unsigned integer)

A port number, other than 0.

NAS-Port-Type

(32-bit unsigned integer)

Always set to 19, which represents WIRELESS_802_11.

Message-Authenticator

(string)

As defined in RFC 2869. Always present even when not doing an EAP authentication. length = 16 bytes.

Service-Type

(32-bit unsigned integer)

RADIUS service type.

State

(string)

As defined in RFC 2865.

User-Name

(string)

The username assigned to the user or a device when using MAC authentication.

User-Password

(string)

The password supplied by a user or device when logging in. Encoded as defined in RFC 2865. Only present when the authentication method for the RADIUS profile is set to PAP.

Vendor-specific (Microsoft)

HP ProCurve supports the following Microsoft vendor-specific attributes.

MSCHAP-Challenge

(string)

As defined in RFC 2433. Only present when the authentication method for the RADIUS profile is set to MSCHAPv1 or MSCHAPv2. Length = 8 bytes.

MSCHAP-Response

(string)

As defined in RFC 2433. Only present when the authentication method for the RADIUS profile is set to MSCHAPv1. Length = 49 bytes.

MSCHAPv2-Response

(string)

As defined in RFC 2759. Only present when the authentication method for the RADIUS profile is set to MSCHAPv2. Length = 49 bytes.

Vendor-specific (WISPr)

HP ProCurve supports the following Wi-Fi Alliance vendor-specific attributes.

Location-Name

The WISPr location name assigned to the controller.

- SMI network management private enterprise code = 14122
- Vendor-specific attribute type number = 2
- Attribute type: A string in the format: *wispr-location-name=location_name*

Location-ID

The WISPr location identifier assigned to the controller.

- SMI network management private enterprise code = 14122
- Vendor-specific attribute type number = 1
- Attribute type: A string in the format: *wispr-location-id=location_id*

Logoff-url

The WISPr log-off URL that will be used.

- SMI network management private enterprise code = 14122
- Vendor-specific attribute type number = 3
- Attribute type: A string in the format: *wispr-logoff-url=URL*

Access accept

Acct-Interim-Interval

(32-bit unsigned integer)

When present, enables the transmission of RADIUS accounting requests of the Interim Update type. Specify the number of seconds between each transmission.

Chargeable User Identity (CUI)

(string)

As defined in RFC-4372. The CUI is used to associate a unique identifier with a user so that the user can be identified (for billing, authentication or other purposes) when roaming outside of their home network.

Class

(string)

As defined in RFC 2865. Multiple instances are supported.

EAP-Message

(string)

Only supported when authentication is EAP-MD5. Note that the content will not be read as the RADIUS Access Accept overrides whatever indication is contained inside this packet.

Idle-Timeout

(32-bit unsigned integer)

Maximum idle time in seconds allowed for the user. Once reached, the user session is terminated with termination-cause IDLE-TIMEOUT. Omitting the attribute or specifying 0 disables the feature.

Reply-Message

(string)

This string (as defined in RFC 2865) is recorded and passed as is to the GetRadiusReplyMessage() asp function. Multiple string are supported to a maximum length of 252 bytes.

Session-Timeout

(32-bit unsigned integer)

Maximum time a session can be active. The user must re-authenticate when this timer expires. Omitting this attribute or specifying 0 disables the feature.

Termination-Action

(32-bit unsigned integer)

As defined by RFC 2865. If set to 1, a new Access Request is sent. If an Access Accept is returned, the controller then extends the users session timeout, and if applicable, session quota, according the value returned by the RADIUS server.

Tunnel-Medium-Type

(24-bit unsigned integer)

Only used when assigning a specific VLAN number to a user. In this case it must be set to 802. The **tag** field for this attribute must be set to 0.

Tunnel-Private-Group-ID

(string)

Only used when assigning a specific VLAN number to a user. In this case it must be set to the VLAN ID. The **tag** field for this attribute must be set to 0.

Tunnel-Type

(24-bit unsigned integer)

Only used when assigning a specific VLAN number to a user. In this case it must be set to 13 (VLAN). The **tag** field for this attribute must be set to 0.

Vendor-specific (Microsoft)

HP ProCurve supports the following Microsoft vendor-specific attributes.

MS-MPPE-Recv-Key

(string)

Use to validate a PMKID inside a 802.11 association request, send EAPOL keys to a wireless station when a VSC has 802.1X WEP enabled, and to perform a four-way handshake.

MS-MPPE-Send-Key

(string)

Use to validate a PMKID inside a 802.11 association request, send EAPOL keys to a wireless station when a VSC has 802.1X WEP enabled, and to perform a four-way handshake.

Vendor-specific (Colubris)

(string)

Colubris AV-Pair

The Colubris AV-Pair is a HP ProCurve a vendor-specific attribute defined by HP to support configuration of user session settings. This attribute conforms to RADIUS RFC 2865. You may need to define this attribute on your RADIUS server (if it is not already present) using the following values:

- SMI network management private enterprise code = 8744
- Vendor-specific attribute type number = 0
- Attribute type: A string in the following format `<keyword>=<value>`

Multiple instances of the Colubris AV-Pair can be defined in a RADIUS account to configure a variety of settings. For a complete list of all supported settings, see [“Colubris AV-Pair - Site attribute values”](#) (page 458).

Colubris-Intercept

This attribute is used to enable/disable the interception and redirection of traffic for individual users. The destination for intercepted traffic is defined separately for each VSC using the **Interception** option under **VSC egress mapping**. See [“VSC egress mapping”](#) (page 123).

You may need to define the Colubris-Intercept attribute on your RADIUS server (if it is not already present) using the following values:

- SMI network management private enterprise code = 8744
- Vendor-specific attribute type number = 1
- Attribute type = integer with one of the following values:
 - **0**: Do not intercept user traffic.
 - **1**: Intercept user traffic and redirect it to the destination defined by the **Intercepted** option under **VSC egress mapping** in the VSC to which the user is connected.

Access reject

EAP-Message

(string)

Only supported when authentication is EAP-MD5. Note that the content will not be read as the RADIUS Access Reject overrides whatever indication is contained inside this packet.

Vendor-specific (Microsoft)

HP ProCurve supports the following Microsoft vendor-specific attributes.

MSCHAP-Error

(string)

A MSCHAP specific error as defined by RFC 2433.

Reply-Message

(string)

This string (as defined in RFC 2865) is recorded and passed as is to the `GetRadiusReplyMessage()` asp function. Multiple string are supported to a maximum length of 252 bytes.

Access challenge

EAP-Message

(string)

One or more occurrences of this attribute is supported inside the same packet. All occurrences are concatenated and transmitted to the IEEE802dot1x client as is. As defined in RFC 2869.

State

(string)

As defined in RFC 2865.

Accounting request

Accounting start, stop. and interim-update

Acct-Authentic

(32-bit unsigned integer)

Always set to 1 which means RADIUS.

Acct-Delay-Time

(32-bit unsigned integer)

As defined in RFC 2869.

Acct-Event-Timestamp

(32-bit unsigned integer)

As defined in RFC 2869.

Acct-Session-Id

(32-bit unsigned integer)

Random value generated by the controller.

Acct-Status-Type

(32-bit unsigned integer)

Supported value are: Start (1), Interim Update (3), and Stop (2).

Calling-Station-Id

(string)

The MAC address of the users computer in IEEE format. For example: 00-02-03-5E-32-1A.

Called-Station-Id

(string)

The MAC address of the controller LAN port in IEEE format. For example: 00-02-03-5E-32-1A.

Chargeable User Identity (CUI)

(string)

As defined in RFC-4372. The CUI is used to associate a unique identifier with a user so that the user can be identified (for billing, authentication or other purposes) when roaming outside of their home network.

Class

(string)

As defined in RFC 2865. Multiple instances are supported.

Framed-IP-Address

(32-bit unsigned integer)

IP Address of the users computer.

NAS-Identifier

(string)

The NAS ID for the RADIUS profile being used.

NAS-Ip-Address

(32-bit unsigned integer)

The IP address of the port the controller is using to communicate with the RADIUS server.

NAS-Port

(32-bit unsigned integer)

A virtual port number starting at 1. Assigned by the controller.

NAS-Port-Type

(32-bit unsigned integer)

Always set to 19, which represents WIRELESS_802_11.

User-Name

(string)

The username assigned to the user or to a device when using MAC authentication.

Vendor-specific (WISPr)

HP ProCurve supports the following Wi-Fi Alliance vendor-specific attributes.

Location-Name

The WISPr location name assigned to the controller.

- SMI network management private enterprise code = 14122
- Vendor-specific attribute type number = 2
- Attribute type: A string in the format: *wispr-location-name=location_name*

Location-ID

The WISPr location identifier assigned to the controller.

- SMI network management private enterprise code = 14122
- Vendor-specific attribute type number = 1
- Attribute type: A string in the format: *wispr-location-id=location_id*

Logoff-url

The WISPr log-off URL that will be used.

- SMI network management private enterprise code = 14122
- Vendor-specific attribute type number = 3
- Attribute type: A string in the format: *wispr-logoff-url=URL*

Accounting stop. and interim-update

Acct-Session-Time

(32-bit unsigned integer)

Number of seconds this session since this session was authenticated. Only present when **Acct-Status-Type** is **Interim-Update** or **Stop**.

Acct-Input-Gigawords

(32-bit unsigned integer)

High 32-bit value of the number of octets/bytes received by the user. Only present when **Acct-Status-Type** is **Interim-Update** or **Stop**.

Acct-Input-Octets

(32-bit unsigned integer)

Low 32-bit value of the number of octets/bytes received by the user. Only present when **Acct-Status-Type** is **Interim-Update** or **Stop**.

Acct-Input-Packets

(32-bit unsigned integer)

Low 32-bit value of the number of packets/bytes received by the user. Only present when **Acct-Status-Type** is **Interim-Update** or **Stop**.

Acct-Output-Gigawords

(32-bit unsigned integer)

High 32-bit value of the number of octets/bytes sent by the user. Only present when **Acct-Status-Type** is **Interim-Update** or **Stop**. As defined in 2869.

Acct-Output-Octets

(32-bit unsigned integer)

Low 32-bit value of the number of octets/bytes sent by the user. Only present when **Acct-Status-Type** is **Interim-Update** or **Stop**.

Acct-Output-Packets

(32-bit unsigned integer)

Low 32-bit value of the number of packets/bytes sent by the user. Only present when **Acct-Status-Type** is **Interim-Update** or **Stop**.

Accounting stop only

Acct-Terminate-Cause

(32-bit unsigned integer)

Termination cause for the session See RFC 2866 for possible values. Only present when **Acct-Status-Type** is **Stop**.

ID	Cause	Notes
1	User Request	Supported. Indicates that the user logged out.
2	Lost Carrier	Supported. Indicates that the client station is no longer alive.
3	Lost Service	Supported. When location-aware is enabled and a user switches access points, the controller re-authenticates the user. If authentication fails due to timeout, this code is returned.
4	Idle Timeout	Supported. User exceeded the idle timeout value defined for the session.
5	Session Timeout	Supported. User exceeded maximum time defined for the session.
6	Admin Reset	Supported. User session was terminated by the controller administrator via SNMP or the management tool.
7	Admin Reboot	Not Supported. (not applicable)
8	Port Error	Supported. If two users are detected using the same IP address, both are logged out with this error. Another cause is if an error is encountered in an access list definition. For example, an invalid host was specified.
9	NAS Error	Not Supported. (not applicable)
10	NAS Request	Not Supported. (not applicable)
11	NAS Reboot	Supported. User was logged out because the controller was restarted.
12	Port Unneeded	Not Supported. (not applicable)
13	Port Preempted	Supported. When a user switches AP or SSID with incompatible configurations (authentication type), they are logged out with this code. Also if the user changes authentication type of the same AP.
14	Port Suspended	Not Supported. (not applicable)
15	Service Unavailable	Not Supported. (not applicable)
16	Callback	Not Supported. (not applicable)
17	User Error	Supported. An 802.1X client initiated a second authentication request for a user, and this request was refused.

ID	Cause	Notes
18	Host Request	Not Supported. (not applicable)
0x8744 (34628 decimal)	Termination	HP-specific termination cause.

Accounting response

No attributes are supported.

Administrator attributes

If you want to support multiple administrator names and passwords, you must use a RADIUS server to manage them. The controller only supports a single admin name and password internally (defined on the **Controller >> Management > Management tool** page).

NOTE: Improper configuration of the administrator profile could expose the controller to access by any user with a valid account. The only thing that distinguishes an administrative account from that of a standard user account is the setting of the service type. Make sure that a user is not granted access if service type is not Administrative, This is the reason why it may be prudent to use a different RADIUS server to handle administrator logins. This practice reduces the risk of a bad configuration on the RADIUS server side creating a security hole.

The following attributes are supported for administrator accounts.

Access Request

- **Framed-MTU**
- **NAS-Identifier**
- **User-Name**
- **Service-Type**
- **Vendor-specific (Microsoft)**
 - **MSCHAP-Challenge**
 - **MSCHAP-Response**

Access Accept

- **Vendor-specific (Colubris)**

Access Reject

No attributes are supported.

Access Challenge

No attributes are supported.

Accounting Request

No attributes are supported.

Accounting Response

No attributes are supported.

Access request

Framed-MTU

(32-bit unsigned integer)

Hard-coded value of 1496. The value is always four bytes lower than the wireless MTU maximum which is 1500 bytes in order to support IEEE802dot1x authentication.

NAS-Identifier

(string)

The NAS ID set on the **Controller >> Authentication > RADIUS profiles > Add New Profile** page for the RADIUS profile being used.

User-Name

(string)

The username assigned to the administrator.

Service-Type

(32-bit unsigned integer)

As defined in RFC 2865. Set to a value of 6, which indicates SERVICE_TYPE_ADMINISTRATIVE.

Vendor-specific (Microsoft)

HP ProCurve supports the following Microsoft vendor-specific attributes.

MSCHAP-Challenge

(string)

As defined in RFC 2433. Only present when the authentication method for the RADIUS profile is set to MSCHAPv1 or MSCHAPv2. Length = 8 bytes.

MSCHAP-Response

(string)

As defined in RFC 2433. Only present when the authentication method for the RADIUS profile is set to MSCHAPv1. Length = 49 bytes.

Access accept

Vendor-specific (Colubris)

(string)

Colubris AV-Pair

HP ProCurve has defined a vendor-specific attribute to support configuration of user session settings. This attribute conforms to RADIUS RFC 2865. You may need to define this attribute on your RADIUS server (if it is not already present) using the following values:

- SMI network management private enterprise code = 8744
- Vendor-specific attribute type number = 0
- Attribute type: A string in the following format `<keyword>=<value>`

Multiple instances of the Colubris AV-Pair can be defined in a RADIUS account to configure a variety of settings. For a complete list of all supported attributes, see [“Colubris AV-Pair - Administrator attribute values”](#) (page 489).

Colubris AV-Pair - Site attribute values

Site values let you define global settings that affect operation of the public access network and all user accounts.

Each Colubris AV-Pair value is specified using the following format: `<keyword>=<value>`

The following table lists all supported site value keywords and provides a link to complete descriptions for each one.

Colubris AV-Pair keyword	For more information see
access-list use-access-list=uselistname use-access-list-unauth=uselistname default-user-access-list	“Access list” (page 460)
configuration-file	“Configuration file” (page 467)
ssl-certificate	“Custom SSL certificate” (page 467)
custom-pages	Loading custom pages from an archive
login-page	Loading individual pages

Colubris AV-Pair keyword	For more information see
transport-page session-page fail-page logo	<i>These keywords have been deprecated. If you are creating a new installation, use the custom-pages keyword or the site file archive feature on the Controller >> Public access > Web content page. If you are upgrading from a previous release, your existing configuration will still work.</i>
welcome-url login-err goodbye-url	Hosting pages on an external Web server
login-url	Remote login page
messages	Custom message file
default-user-acct-interim-update	"Default user interim accounting update interval" (page 472)
default-user-bandwidth-level	"Default user bandwidth level" (page 473)
default-user-idle-timeout	"Default user idle timeout" (page 473)
default-user-one-to-one-nat	"Default user one-to-one NAT" (page 474)
default-user-use-public-ip-subnet	"Default user public IP address" (page 475)
default-user-session-timeout	"Default user session timeout" (page 474)
default-user-smtp-redirect	"Default user SMTP server" (page 475)
default-user-welcome-url default-user-goodbye-url	"Default user URLs" (page 475)
default-user-max-input-packets default-user-max-output-packets default-user-max-total-packets default-user-max-input-octets default-user-max-output-octets default-user-max-total-octets	"Default user quotas" (page 473)
default-user-max-input-rate=value default-user-max-output-rate=value	"Default user data rates" (page 474)
http-proxy-upstream	"HTTP proxy upstream" (page 475)
ipass-login-url	"IPass login URL" (page 476)
mac-address	"Global MAC-based authentication" (page 476)
primary-web-server-status-url secondary-web-server-status-url primary-web-server-status-url secondary-web-server-status-url	"Multiple login servers" (page 477)
redirect-url	"Redirect URL" (page 479)
ssl-noc-certificatessl-noc-ca-certificate	"NOC authentication" (page 480)
wispr-login-urlwispr-abort-login-url redirect-pageaccess-procedure	"HP WISPr support" (page 481)
dnat-server	"Traffic forwarding (dnat-server)" (page 482)

Colubris AV-Pair keyword	For more information see
primary-dnat-server-status-url secondary-dnat-server-status-url	

Access list

Access lists enable you to create public areas on your network that all users can browse, and protected areas that are restricted to specific user accounts or groups.

Each access list is a set of rules that governs how the controller controls access to network resources. You can create multiple access lists, each with multiple rules to manage the traffic on your public access network.

Default setting

By default no access lists are defined. This means that:

- If authentication (802.1X, WPA, HTML, MAC) is not enabled on a VSC, all users that connect to the VSC have access to the protected network.
- If authentication (802.1X, WPA, HTML, MAC) is enabled on a VSC, then:
 - Unauthenticated users only reach the public access login page. Access to the protected network is blocked, except for **register.procurve.com** which enables product registration.
 - Authenticated users have access to the protected network.

How the access lists work

Access lists can be applied on the controller (site access lists), in which case they affect all user traffic, or individually for each user account (user access lists).

Incoming traffic cascades through the currently active lists. Traffic that is accepted or denied by a list is not available to the list that follows it. Traffic that passes through all lists without being accepted or denied is dropped.

- Access list rules that **accept** traffic are: ACCEPT, ACCEPT-MORE, DNAT-SERVER, and REDIRECT.
- Access list rules that **deny** traffic are: DENY and WARN.

The following diagram illustrates how incoming traffic from a user session is processed by the access list mechanism.

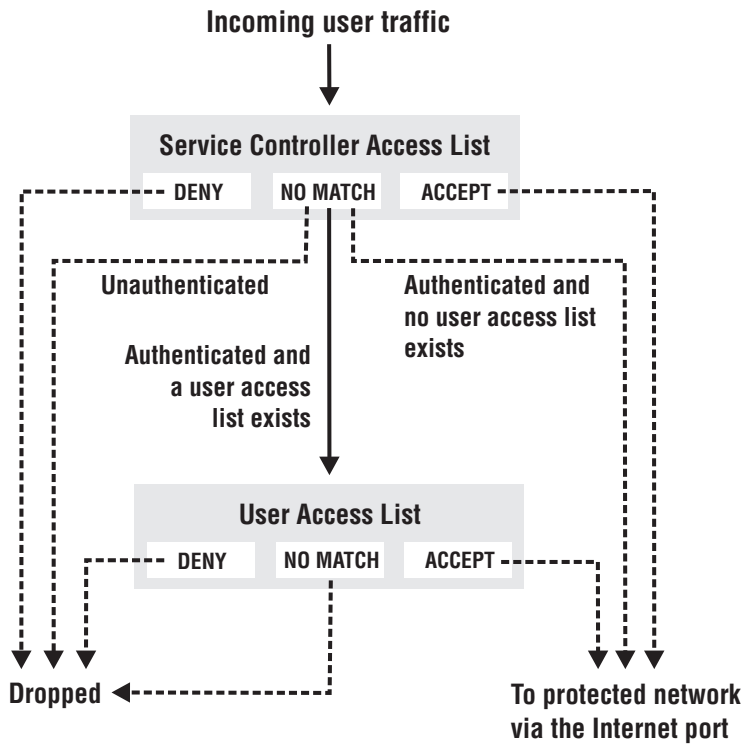

Within each access list, traffic cascades through the list rules in a similar manner.

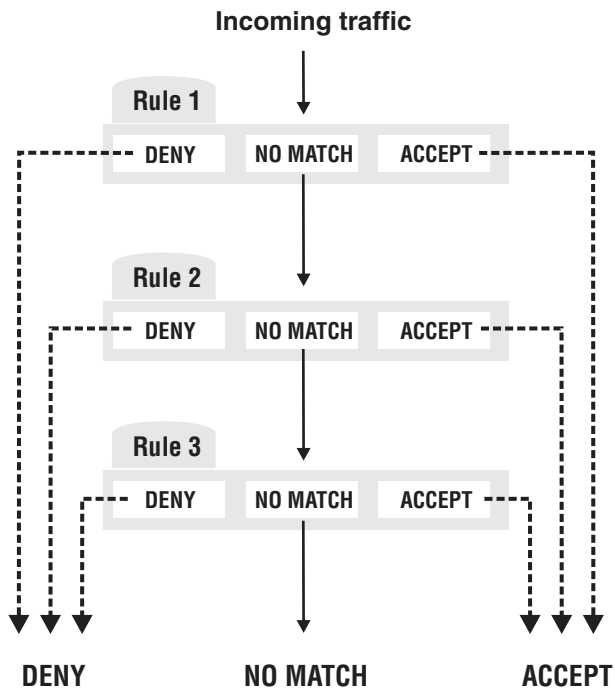

Access list rules are numbered according to the order in which they are specified. Only data that is not accepted or denied by a rule is available to the next rule in the list.

Accounting support

Each rule in an access list can be configured with an account name for billing purposes. The controller sends billing information based on the amount of traffic matched by the rule. This lets you create rules to track and bill traffic to particular destinations.

Tips on using the access list

With certificates

- If you replaced the default SSL certificate on the controller with one signed by a well-known CA, you should define the access list to permit access to the CA certificate for all non-authenticated users. This enables the users browser to verify that the certificate is valid without displaying any warning messages.
- Users may have configured their Web browsers to check all SSL certificates against the Certificate Revocation List (CRL) maintained by the CA that issued the certificate. The location of the CRL may be configured in the browser, or embedded in the certificate. The access list should be configured to permit access to the CRL, otherwise the users browser times out before displaying the login page.

Remote login page

If you are using the remote login page feature, make sure that access to the Web server hosting the login page is granted to all unauthenticated users via the site access list.

SMTP redirect

If an unauthenticated user establishes a connection to their E-mail server, the SMTP redirect feature will not work once the user logs in. The users E-mail is still sent to the original E-mail server.

To avoid this, do not use an access list to open TCP port 25 for unauthenticated users.

Critical access list definitions (such as for a remote login page, certificates) should not use the OPTIONAL setting because if these definitions fail to initialize there is no indication in the log.

Defining access lists

Access lists are defined by adding the following Colubris AV-Pair value string to the RADIUS profile for a controller or to the local list (**Public access > Attributes** page).

```
access-list=value
```

Each value string defines one rule. Up to 99 rules can be defined for an access list.

All rules that make up an access list must be initialized without error for the list to be active. (You can force the controller to ignore initialization errors on a rule-by-rule basis by using the OPTIONAL parameter.)

You can define up to 32 access lists.

Activating site access lists

When an access list is activated on the controller, it applies to all access controlled user traffic handled by the controller.

Access lists are activated by adding the following Colubris AV-Pair value string to the RADIUS profile for a controller or to the local list (**Public access > Attributes** page).

```
use-access-list=uselistname
```

Only one access list can be active on the controller. This list must be initialized without an error.

It is possible to set an access list to apply only for unauthenticated users by specifying the following value string:

```
use-access-list-unauth=uselistname
```

User access lists

Access lists can also be activated on a per-user basis by configuring the appropriate settings for each user account. See [“Access list” \(page 484\)](#) for more information.

A default access list can be defined by adding the following Colubris AV-Pair value string to the RADIUS profile for a controller or to the local list (**Public access > Attributes** page). This defines the access list to use for all users whose profiles do not contain an access list value.

```
default-user-access-list=uselistname
```

Syntax

```
access-list=
listname[, [OPTIONAL]], action, protocol, address, port[, account[, interval]]
use-access-list=uselistname
default-user-access-list=uselistname
use-access-list-unauth=uselistname
```

NOTE: You can use spaces as separators instead of commas.

Where:

Parameter	Description
<i>listname</i>	Specify a name (up to 32 characters long) to identify the access list this rule applies to. If a list with this name does not exist, a new list is created. If a list with this name exists, the rule is added to it.
<i>uselistname</i>	Specify the name of an existing access list. This list is activated for the current profile. Lists are checked in the order they are activated.
[OPTIONAL]	Allows the access list to be activated even if this rule fails to initialize. For example, if you specify a rule that contains an address which cannot be resolved for some reason, the other rules that make up the access list will still be initialized. If you do not specify optional, a failed rule will cause the entire list to fail. Critical access list definitions (such as for a remote login page, certificates) should not use the OPTIONAL setting because if these definitions fail to initialize there will be no indication in the log.
<i>action</i>	Specify what action the rule takes when it matches incoming traffic. The options are: <ul style="list-style-type: none"> ACCEPT - Allow traffic matching this rule. ACCEPT-MORE - Allow traffic matching this rule and allocate extra connections (when required) to enable users to connect with the specified <i>address</i>. <p>By default the controller allows up to 200 TCP or UDP connections per authenticated or unauthenticated user. If a user has exceeded this connection limit, this parameter allows the controller to permit extra connections from the user when connecting to the specified destination. Connections are assigned from a global pool of 100 connections.</p>
<i>action</i> (continued)	This can be used to make sure that users can always reach an important resource on the network. For example, the following access list definition allows additional connections as needed to any user who is trying to reach my-web-server.com . <pre>access-list=HP, ACCEPT-MORE, all, my-web-server.com, 80 use-access-list=procurve</pre> <ul style="list-style-type: none"> DENY - Reject traffic matching this rule. DNAT-SERVER: Traffic matching this rule is forwarded to the destination defined by the dnat-server value. See “Traffic forwarding (dnat-server)” (page 482) for more information. Note: SSL traffic cannot be forwarded as this breaks SSL security during connection negotiation resulting in the connection not being established. REDIRECT: Reject traffic matching this rule and redirect the users Web browser to the page specified by redirect-url, or login-url if redirect-url is not defined. See “Redirect URL” (page 479) for more information. For

Parameter	Description
	<p>example, one use for this feature could be to block access to a popular protocol, then prompt the user for additional fees to activate support.</p> <ul style="list-style-type: none"> • WARN: Reject traffic matching this rule and return an HTTP error message (which is not customizable) indicating that access to the site is not allowed by the network.
<i>protocol</i>	Specify the protocol to check: <code>tcp</code> , <code>udp</code> , <code>icmp</code> , <code>all</code>
<i>address</i>	<p>Specify one of the following:</p> <ul style="list-style-type: none"> • IP address or domain name (up to 107 characters in length) • Subnet address. Include the network mask as follows: <code>address/subnet mask</code> For example: <code>192.168.30.0/24</code> • Use the keyword <code>all</code> to match any address. • Use the wildcard symbol <code>*</code> to match any sequence of characters at the beginning or the end of a domain name. For example: <ul style="list-style-type: none"> <code>*.mydomain</code> matches any host on the <code>domain.mydomain</code>. <code>myhost.*</code> matches myhost at any domain. For example, <code>myhost.com</code> or <code>myhost.ca</code> • Use the keyword <code>none</code> if the protocol does not take an address range (ICMP for example).
<i>port</i>	<p>Specify a specific port to check or a port range as follows:</p> <ul style="list-style-type: none"> • <code>none</code> - Used with ICMP (since it has no ports). • <code>all</code> - Check all ports. • <code>1-65535[:1-65535]</code> - Specify a specific port or port range. <p>NOTE: If you choose all possible protocols for an access-list definition, then you must supply all ports as well.</p>
<i>account</i>	Specify the name of the user account the controller will send billing information to for this rule. Account names must be unique and can be up to 32 characters in length.
<i>interval</i>	Specify time between interim accounting updates. If you do not enable this option, accounting information is only sent when a user connection is terminated. Range: 5 to 99999 seconds in 15 second increments.

Access list example

This example illustrates how access lists can be used to control access to network resources for different groups of users at a fictitious university campus.

Topology

The following two topologies show potential wireless deployments for the campus using different types of HP equipment. In both cases, a RADIUS server is used to store configuration attributes for the public access network. Although the topologies are slightly different, the same access list definitions are used for both installations.

Topology 1:

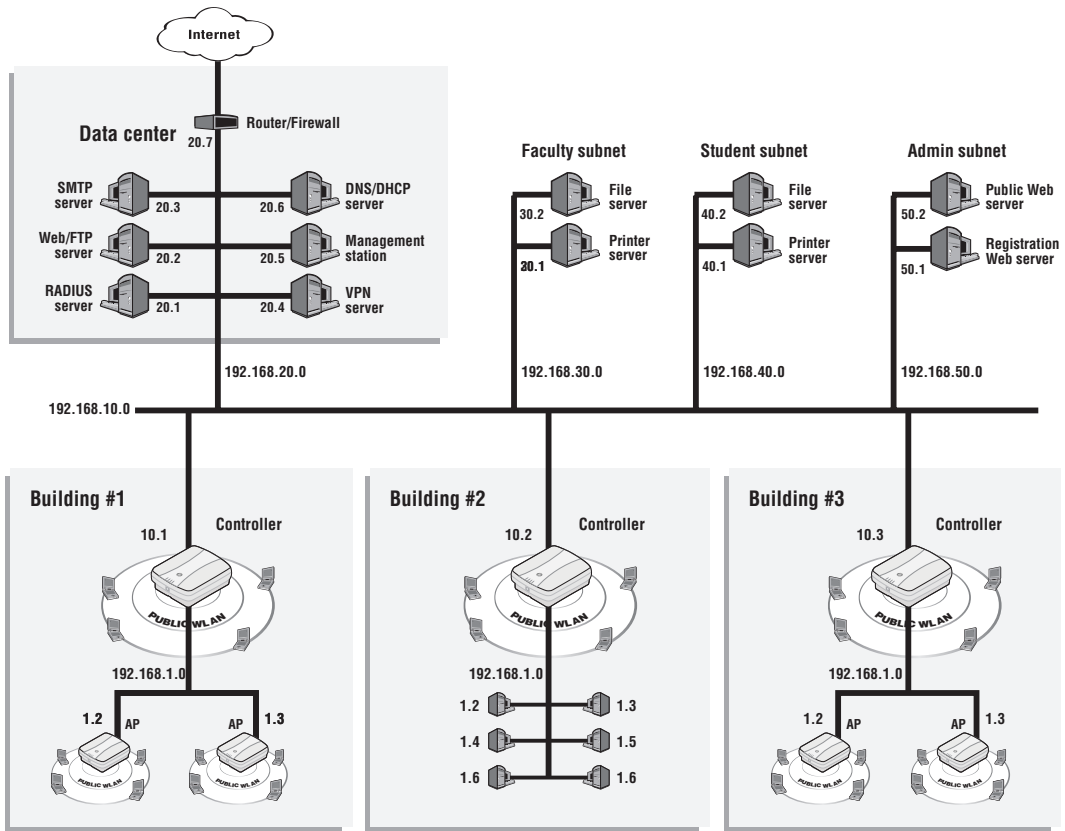

Topology 2:

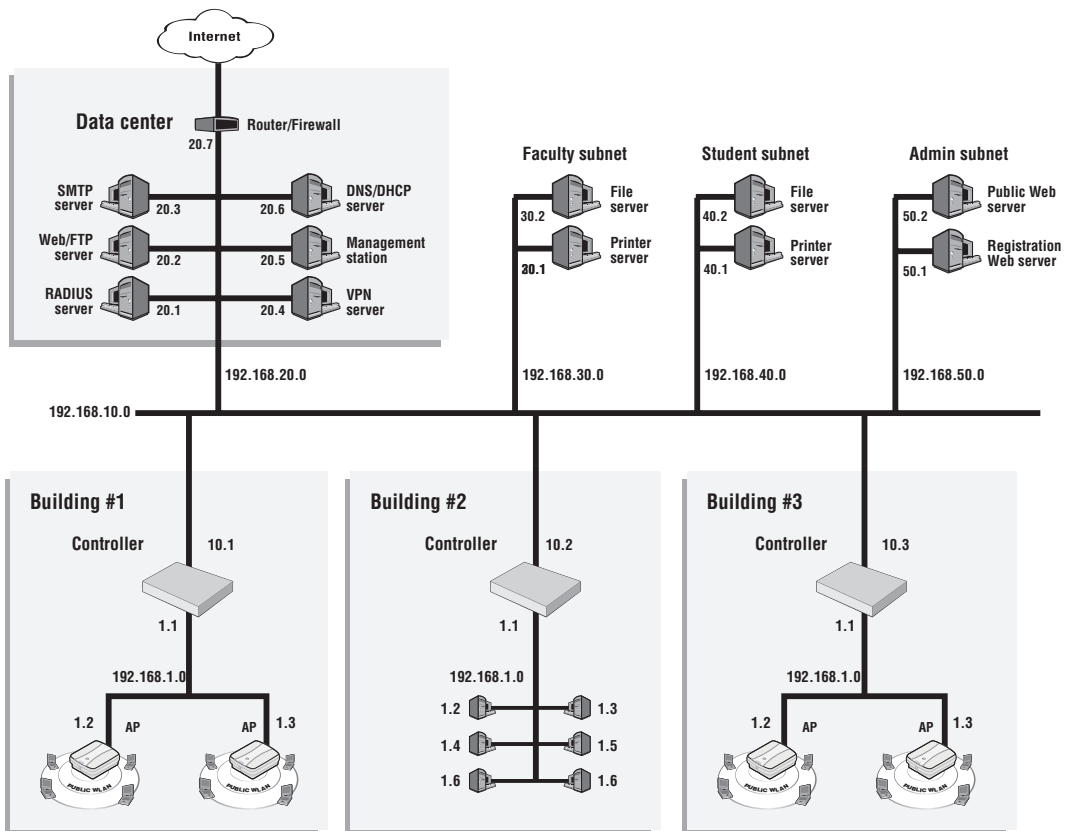

[Access list definitions](#)

The RADIUS profile for the controller contains the following:

```
access-list=everyone,ACCEPT,tcp,192.168.50.2,80
```

```
access-list=students,ACCEPT,tcp,192.168.50.1,80,students_reg,500  
access-list=students,ACCEPT,all,192.168.40.0/24,all  
access-list=students,DENY,all,192.168.20.0/24,all  
access-list=students,DENY,all,192.168.30.0/24,all  
access-list=students,ACCEPT,all,all.all,student_internet_use,5000
```

```
access-list=faculty,ACCEPT,tcp,192.168.50.1,80,faculty_reg,500  
access-list=faculty,ACCEPT,all,192.168.30.0/24,all  
access-list=faculty,DENY,all,192.168.20.0/24,all  
access-list=faculty,DENY,all,192.168.40.0/24,all  
access-list=faculty,ACCEPT,all,all.all,faculty_internet_use,5000
```

```
use-access-list=everyone
```

The RADIUS profile for every student contains the following:

```
use-access-list=students
```

The RADIUS profile for every faculty member contains the following:

```
use-access-list=faculty
```

This definitions create three access lists: everyone, students, and faculty.

Everyone

This list applies to all users (students, teachers, guests), whether they are authenticated or not. This is because the list is active on the controller, which is accomplished with the entry:

```
use-access-list=everyone
```

It enables everyone to access the public Web server.

Students

This list applies to authenticated students only. It is composed of the following entries:

```
access-list=students,ACCEPT,tcp,192.168.50.1,80,students_reg,500
```

Enables Web traffic to the registration Web server. Accounting data is recorded in the account students_reg.

```
access-list=students,ACCEPT,all,192.168.40.0/24,all
```

Enables traffic to reach the student segment.

```
access-list=students,DENY,all,192.168.20.0/24,all
```

```
access-list=students,DENY,all,192.168.30.0/24,all
```

These two entries deny access to the faculty subnet and the NOC.

```
access-list=students,ACCEPT,all,all.all,student_internet_use,5000
```

Enables all other traffic to reach the Internet (via routers on the backbone LAN and the router in the NOC). If this last rule did not exist, this traffic would be dropped.

Faculty

This list applies to authenticated faculty members only. It is composed of the following entries:

```
access-list=faculty,ACCEPT,tcp,192.168.50.1,80,faculty_reg,500
```

Enables Web traffic to the registration Web server. Accounting data is recorded in the account faculty_reg.

```
access-list=faculty,ACCEPT,all,192.168.30.0/24,all
```

Enables traffic to reach the faculty segment.

```
access-list=faculty,DENY,all,192.168.20.0/24,all
```

```
access-list=faculty,DENY,all,192.168.40.0/24,all
```

These two entries deny access to the student subnet and the NOC.

```
access-list=faculty,ACCEPT,all,all.all,faculty_internet_use,5000
```

Enables all other traffic to reach the Internet (via routers on the backbone LAN and the router in the NOC). If this last rule did not exist, this traffic would be dropped.

Configuration file

The controller can retrieve and load a new configuration file automatically, based on the URL you specify.

Syntax

```
configuration-file=URL [placeholder ]
```

Where:

Parameter	Description
URL	Specify the URL that points to the new configuration file.

By using the following placeholders, you can customize the URL for each controller. This is useful when you need to update multiple units.

Placeholder	Description
%n	Returns the NAS ID assigned to the controller. By default, this is the unit serial number.
%s	Returns the RADIUS login name assigned to the controller on the Public access > Attributes page. By default, this is the unit serial number.
%i	Returns the domain name assigned to the controller Internet port.
%a	Returns the IP address of the controller Internet port.

Custom SSL certificate

The controller can retrieve a custom SSL security certificate to replace the HP ProCurve certificate that is included by default.

Syntax

```
ssl-certificate=URL [placeholder ]
```

Where:

Parameter	Description
URL	Specify the URL that points to the new certificate.

By using the following placeholders, you can customize the URL for each controller. This is useful when you need to update multiple units.

Placeholder	Description
%n	Returns the NAS ID assigned to the controller. By default, this is its serial number.
%s	Returns the RADIUS login name assigned to the controller. By default, this is its serial number.

Placeholder	Description
%i	Returns the domain name assigned to the controller Internet port.
%a	Returns the IP address of the controller Internet port.

The certificate is encoded using PKCS#12 format, and contains:

- the private key of the Web server
- the certificate of the Web server

The file is locked using a password.

NOTE: The password with which the certificate was locked must be the same as the password specified on the **Public access > Attributes** page. This is the password the controller uses to login to the RADIUS server.

Example

ssl-certificate=http://www.mycompany.com/%s_certificate

Custom public access interface Web pages

Several options are available to define custom pages.

Loading custom pages from an archive

This option enables you load site files from an external file archive, allowing you to replace the entire public access Web site in one simple operation. The archive must be in .zip format.

NOTE: The contents of the existing public access site is deleted and replaced by the contents of the archive (.zip) file. If the archive does not contain a complete set of valid pages, the public access interface will not function correctly.

NOTE: When unzipped the total size of all files must be less than 1 MB.

Syntax

custom-pages= *ArchiveURL*

Where:

Parameter	Description
<i>ArchiveURL</i>	URL of the .zip archive to be loaded.

Loading individual pages

These keywords have been deprecated. If you are creating a new installation, use the **custom-pages** keyword or the **site file archive** feature on the **Controller >> Public access > Web content** page. If you are upgrading from a previous release, your existing configuration will still work.

Use the following values to retrieve pages from an external location and load them onto the controller. For descriptions of the individual pages, see [“Current site files” \(page 414\)](#).

NOTE: The maximum length of any page URL is 512 characters. If this is exceeded (when using placeholders for example), the URL is truncated. Therefore, HP recommends that you specify the most-important placeholders first.

The pages can only be changed as a group. You cannot, for example, just specify the login-page value. You must specify all of the following pages:.

Login page

login-page=*URL_of_page* [*placeholder*]

Can be omitted if a remote login page is being used. See [Remote login page](#).

Transport page

`transport-page=URL_of_page [placeholder]`

Session page

`session-page=URL_of_page [placeholder]`

Fail page

`fail-page=URL_of_page [placeholder]`

Logo

`logo=URL_of_gif_file [placeholder]`

Placeholder

The following placeholder is only available when using a RADIUS server. If these values are specified under **Controller >> Public access > Attributes > Configured attributes**, the placeholder cannot be used.

Placeholder	Description
%a	Returns the IP address of the controller Internet port.

Hosting pages on an external Web server

Use the following values to reference pages that reside on an external Web server.

NOTE: The maximum length of any page URL is 512 characters. If this is exceeded (when using placeholders for example), the URL is truncated. Therefore, HP recommends that you specify the most-important placeholders first.

NOTE: The controller maintains a separate copy of the URLs for external pages for each user. This means it is possible to provide different pages for each user. See [“Displaying custom welcome and goodbye pages” \(page 406\)](#).

Welcome page

`welcome-url=URL_of_page [placeholder]`

The user is authenticated, so the welcome page can be located on any URL reachable by the user.

Login error page

`login-err-url=URL_of_page [placeholder]`

Access to the Web server hosting this page must be granted to all unauthenticated users. Do this with an appropriate access list definition. (Users can see this page *before* they are logged in.)

if the radius server denies user authentication, this is used instead of an error being presented on the login page.

Goodbye page

`goodbye-url=URL_of_page [placeholder]`

Access to the Web server hosting this page must be granted to all unauthenticated users. Do this with an appropriate access list definition. (Users see this page *after* they are logged out.)

Remote login page

Use this value to redirect users to a remote server to log in to the public access interface instead of using the internal login page.

Although the remote login page feature enables you to host the public access login page on a remote Web server, authentication of users is still performed by the controller through a RADIUS server or using the local user list. To accomplish this, the remote Web server must send user login information back to the controller. There are two ways this can be done: basic remote

login (as described in this section), or by using the NOC-based authentication feature (described in “NOC authentication” (page 549).

The following diagram shows the sequence of events for a typical user session when using a remote login page and a RADIUS server for authentication.

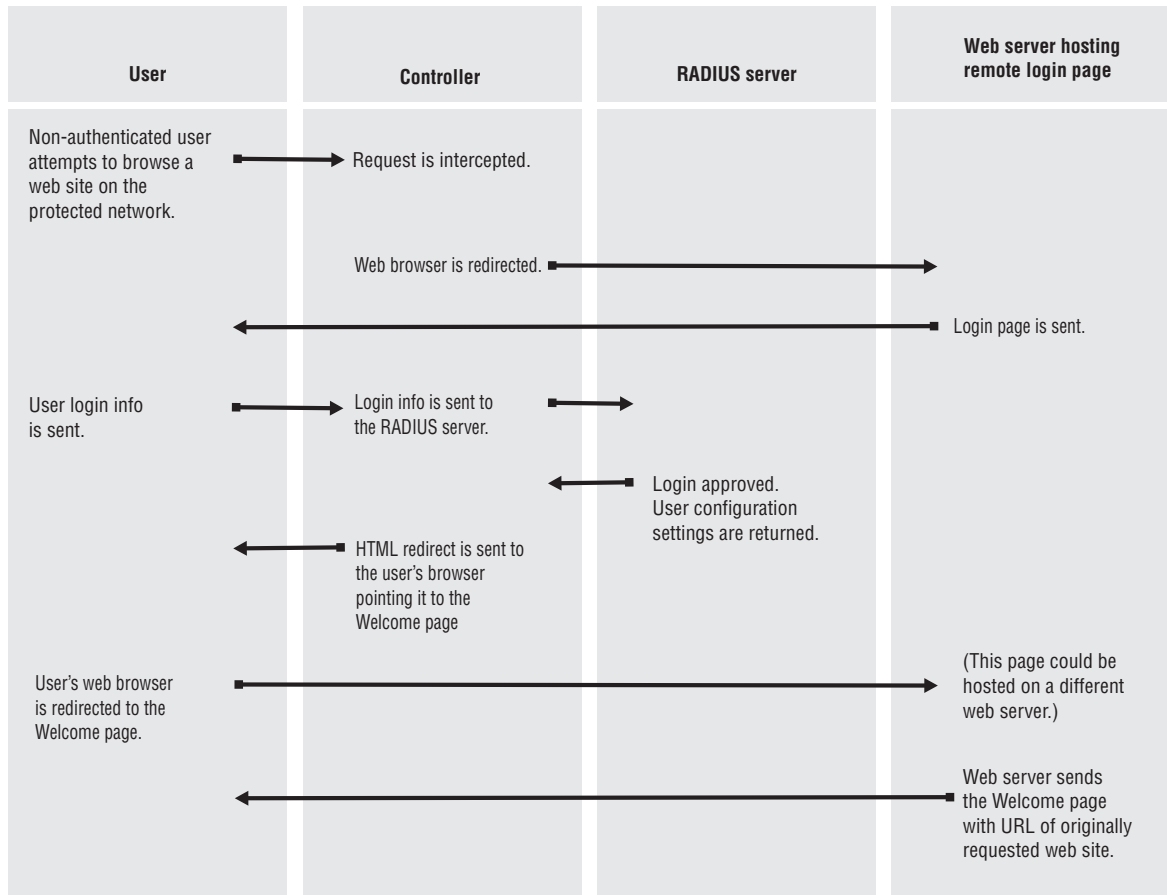

Syntax

`login-url=URL_of_the_page [placeholder]`

Access to the Web server hosting this page must be granted to all unauthenticated users. Do this with an appropriate access list definition. (Users see this page *before* they are logged in.)

Placeholders

An important feature of these pages is that they make it easy to deliver a unique experience for each user. By appending the following optional placeholders to the Colubris AV-Pair value strings, you can pass important information to the Web server. Server-side code can process this information to generate custom pages on-the-fly.

Placeholder	Description
<code>%d</code>	Returns the WISPr location-ID. Supported for login-url only.
<code>%e</code>	Returns the WISPr location-Name. Supported for login-url only.
<code>%l</code>	Returns the URL on the controller where user login information should be posted for authentication. This option is used with the remote login page feature. By default, this value is URL encoded. (To enable/disable URL encoding, set the value of url-encode in the <ACCESS-CONTROLLER> section in the configuration file.)
<code>%n</code>	Returns the NAS ID assigned to the controller. By default, this is the unit serial number. Not supported in local mode.

Placeholder	Description
%s	Returns the RADIUS login name assigned to the controller. By default, this is the unit serial number.
%u	Returns the login name of the user.
%o	Returns the original URL requested by the user. By default, this value is URL encoded. (To enable/disable URL encoding, set the value of url-encode in the <ACCESS-CONTROLLER> section in the configuration file.)
%i	Returns the domain name assigned to the controller Internet port.
%p	Returns the IP port number on the controller where user login information should be posted for authentication.
%a	Returns the IP address of the controller Internet port.
%E	When the location-aware feature is enabled, returns the ESSID of the wireless AP the user is associated with.
%P	When the location-aware feature is enabled, returns the wireless mode ("ieee802.11a", "ieee802.11b", "ieee802.11g") the user is using to communicate with the AP.
%G	When the location-aware feature is enabled, returns the group name of the wireless AP the user is associated with.
%C	When the location-aware feature is enabled, returns the Called-station-id content for the wireless AP the user is associated with.
%r	Returns the string sent by the RADIUS server when an authentication request fails. The RADIUS server must be configured to support this feature. The information contained in the returned string depends on the configuration of the RADIUS server.
%m	Returns the MAC address of the client station that is being authenticated.
%v	Returns the VLAN assigned to the client station at the controller ingress.

Security issues

- HP recommends that the Web server hosting the remote login page be secured with SSL (requires an SSL certificate from a well-known certificate authority), to ensure that user logins are secure. Without SSL security, logins are exposed and may be compromised, enabling fraudulent use of the network.
- Communications between the users browser and the controller is always SSL-based. The default certificate on the controller generates a warning on the users browser unless replaced with a certificate signed by a well-known certificate authority.

Example

1. Create the following folder on your Web sever: `newlogin`.
2. See [“Sample public access pages” \(page 406\)](#). Copy the following sample pages into the `newlogin` folder:
 - `login.html`
 - `transport.html`
 - `session.html`
 - `fail.html`
 - `logo.gif`

3. Add the following entries to the **Configured attributes** table on the **Public access > Attributes** page. (You can also define these attributes in the RADIUS profile for the controller if you are using a RADIUS server.)

```
login-url=web_server_URL/newlogin/login.html?loginurl=%l
transport-page=web_server_URL/newlogin/transport.html
session-page=web_server_URL/newlogin/session.html
fail-page=web_server_URL/newlogin/fail.html
logo=web_server_URL/newlogin/logo.gif
access-list=loginserver,ACCEPT,tcp,web_server_IP_address
use-access-list=loginserver
```

4. Customize login.html to accept username and password information from users and then send it to the controller. You can use code similar to the following example to redirect the users Web browser to the login URL on the controller for authentication:

```
<form action="https://wireless.colubris.com:8090/goform/
HtmlLoginRequest" method="POST">
```

For more flexibility, the remote login page should be written using a server-side scripting language such as ASP, PHP, or PERL. This enables the remote login page to take advantage of any placeholders that may have been defined in the login-url.

Custom message file

Use this value to load a custom message file. These messages are used when various error conditions occur.

```
messages=URL_of_text_file [placeholder ]
```

If you specify a new message file, you must also specify values for:

- Login page
- Transport page
- Session page
- Fail page
- Logo

Placeholders

The following optional placeholder can be appended to the Colubris AV-Pair value for the message file.

Placeholder	Description
%a	Returns the IP address of the controller Internet port.

Default user interim accounting update interval

This keyword lets you define the interim accounting update interval for all users that do not have a specific interval set in their profile.

Syntax

```
default-user-acct-interim-update=value
```

Where:

Parameter	Description
value	Number of seconds between interim updates.

Default user bandwidth level

This keyword lets you define the bandwidth level for all users that do not have a specific level set in their profile.

Syntax

```
bandwidth-level=level
```

Where:

Parameter	Description
<i>level</i>	Specify one of the following the bandwidth levels for the users session. The actual data rate associated with a bandwidth level is defined on the Network > Bandwidth control page. VERY-HIGH HIGH NORMAL LOW

Default user idle timeout

Use this to set the default idle timeout for all users whose RADIUS profile does not contain a value for the RADIUS attribute *idle-timeout*.

Syntax

```
default-user-idle-timeout=seconds
```

Where:

Parameter	Description
<i>seconds</i>	Specify the maximum amount of time a user session can be idle. Once this time expires, the session is automatically terminated. A value of 0 means no timeout.

Default user quotas

These keywords let you define upload and download limits for all users that do not have a specific limit set in their profile. Limits can be defined in terms of packets or octets (bytes).

Syntax

```
default-user-max-input-packets=value  
default-user-max-output-packets=value  
default-user-max-total-packets=value
```

```
default-user-max-input-octets=value  
default-user-max-output-octets=value  
default-user-max-total-octets=value  
default-user-max-input-rate=value  
default-user-max-output-rate=value
```

Where:

Parameter	Description
<i>value</i>	For packets: 32-bit unsigned integer value. For octets: 64-bit unsigned integer value.

When a user session is terminated based on a quota, a new non-standard termination cause is used. The value for this termination cause is 0x8744. You can customize this by modifying the value of "radius-quota-exceeded-cause" in the "ACCESS-CONTROLLER" section of the configuration file.

The text value for the termination cause is defined in the `message.txt` file under the token "stat-quota-exceeded". The default value for this token is "Logged out. (Quota Exceeded.)". This value can be displayed with the ASP function `GetAuthenticationErrorMessage()`. See [GetAuthenticationErrorMessage\(\)](#).

A series of ASP functions are available that enable you to view quota information on the session page. See [Session quotas](#).

Default user data rates

These keywords let you define data rate limits for all users that do not have a specific limit set in their profile.

Syntax

```
default-user-max-input-rate=value  
default-user-max-output-rate=value
```

Where:

Parameter	Description
<i>value</i>	For packets: 32-bit unsigned integer value. For octets: 64-bit unsigned integer value.

Default user one-to-one NAT

This keyword lets you define the default setting for one-to-one NAT support for all users that do not have this setting specified in their profile. This feature only applies to users making IPsec or PPTP VPN connections with a remote site via controller Internet port. For more information, see ["VPN one-to-one NAT" \(page 515\)](#) and ["One-to-one NAT" \(page 486\)](#).

Syntax

```
default-user-one-to-one-nat=value
```

Where:

Parameter	Description
<i>value</i>	Set this to 1 to activate one-to-one NAT support.

Default user session timeout

Use this to set the default session timeout for all users whose RADIUS profile does not contain a value for the RADIUS attribute session-timeout.

Syntax

```
default-user-session-timeout=seconds
```

Where:

Parameter	Description
<i>seconds</i>	Specify the maximum amount of time a user session can be connected. Once this time expires, the session is automatically terminated. A value of 0 means no timeout.

Default user public IP address

Use this to set the default value for public IP address assignment for users whose RADIUS profile does not contain a value for **use-public-ip-subnet** (“Public IP address” (page 486)). For more information using public IP addresses, see “Assigning public IP addresses” (page 47).

Syntax

```
default-user-use-public-ip-subnet=value
```

Where:

Parameter	Description
<i>value</i>	Set this to 1 to activate assignment of a public IP address. Set to 0 to disable.

Default user SMTP server

Use this to set the default SMTP server address for all user sessions. This address is used if a specific server is not set for a particular user.

Syntax

```
default-user-smtp-redirect=hostname [:port ] [,username, password ]
```

Where:

Parameter	Description
<i>hostname</i>	Specify the IP address or domain name of the e-mail server. Maximum length is 253 characters.
<i>port</i>	Specify the port on the e-mail server to relay to. Range: 1 to 65535. Default: 25
<i>username</i>	Specify the username required to log on to the SMTP server. Maximum 32 characters. Only used if the SMTP authentication option is enabled on the Public Access > Access Control page. Works with SMTP servers that support plain or CRAM-MD5 authentication.
<i>password</i>	Specify the password required to log on to the SMTP server. Maximum 32 characters. Only used if the SMTP authentication option is enabled on the Public Access > Access Control page. Works with SMTP servers that support plain or CRAM-MD5 authentication.

Default user URLs

Use this to set the default URLs for the welcome and goodbye pages for all users that do not have default pages specified in their profile.

Syntax

```
default-user-welcome-url=URL
```

```
default-user-goodbye-url=URL
```

Where:

Parameter	Description
<i>URL</i>	Specify the URL of an external Web page.

HTTP proxy upstream

The HTTP proxy upstream feature can be used to force all outgoing TCP traffic to be sent to a third-party upstream HTTP proxy server. When using this feature, outgoing traffic is automatically translated into HTTP proxy format because many HTTP proxies are not able to handle transparent

proxy requests. HTTP requests such as **GET / HTTP/1.0** are transformed into **GET http://www.website.com/HTTP/1.0** before being forwarded to the third-party server.

NOTE: The HTTP proxy upstream feature targets the HTTP protocol and not HTTPS. Because of this, HTTPS only works if users have configured their browsers for HTTP proxy usage. In the case of transparent proxy, the connection will not be detected as HTTP-compatible and will not be redirected to the upstream proxy server.

By default this feature listens to TCP port 8088 on the LAN port. However, it can be configured to capture other ports. This is done by defining an access list and DNAT server. For example:

```
HTTP-Proxy-Upstream=myproxy.com:8888
```

```
Access-List=mylist, DNAT-SERVER, tcp, *mydomain.com, 80
```

```
Use-access-list=mylist
```

```
DNAT-Server=mylist, 192.168.1.1, 8088
```

This example forces any incoming traffic, with a matching target protocol, address, or port number (tcp, *mydomain.com, 80) to be redirected to the internal HTTP proxy. Then, because of the HTTP-Proxy-Upstream keyword, the traffic is forwarded to myproxy.com.

NOTE: The HTTP-Proxy-Upstream definition must exclude any traffic addressed to the controller public access interface, otherwise HTML-based users will not be able to login.

Syntax

```
HTTP-Proxy-Upstream=hostname:port
```

Where:

Parameter	Description
<i>hostname</i>	Specify the IP address or domain name of the proxy server. Maximum length is 253 characters.
<i>port</i>	Specify the port on the proxy server. Range: 1 to 65535.

IPass login URL

This keyword lets you define the location of the IPass login page. The controller will automatically redirect users with IPass client software to this page.

Syntax

```
ipass-login-url=URL_of_page
```

Where:

Parameter	Description
<i>URL_of_page</i>	Address of the IPass login page.

Global MAC-based authentication

The global MAC-based authentication feature enables you to define MAC-based authentication settings that apply across all VSCs.

NOTE: You can also define MAC-based authentication settings on a per-VSC basis. See [“MAC-based authentication” \(page 339\)](#) for a description of all MAC-based authentication options.

To make use of this feature you need to define a local user account or a RADIUS user account for each device as follows:

- **username:** Set this to the username you specified in the mac-address value string. If no username is specified, set the account name to the MAC address of the device. Use dashes to separate characters in the address. For example: 00-20-E0-6B-4B-44.
- **password:** Set this to the password you specified in the mac-address value string. If no password is specified, set this to the same password that is used for the user account.

NOTE: The username and password are not encrypted for transmission so it is important that the link with the RADIUS server is secure.

NOTE: Global MAC-based authentication only applies to VSCs that have HTML-based authentication enabled.

Syntax

```
mac-address=address [,username [,password ]]
```

Where:

Parameter	Description
<i>address</i>	Specify the MAC address of the device to authenticate. Use dashes to separate characters in the address. Do not use colons (:). For example: 00-20-E0-6B-4B-44.
<i>username</i>	Specify the username to associate with this MAC address. Maximum 32 alphanumeric characters. The username field cannot contain a comma.
<i>password</i>	Specify the password to associate with this MAC address. Maximum 32 alphanumeric characters. The password field cannot contain a comma.

Example

Consider the scenario where several APs are installed with a controller. If the APs are going to perform software updates from a remote Web or FTP server, they will need to log in to the public access network. By using MAC-based authentication, this can easily be accomplished.

Multiple login servers

This feature lets you dynamically set the URL used for retrieving custom external pages or a remote login page based on the status of a primary or secondary Web server.

Syntax

```
primary-web-server-status-url=URL_of_page  
secondary-web-server-status-url=URL_of_page
```

Where:

Parameter	Description
<i>URL_of_page</i>	<p>Specify the URL that points to the Web server status file. Use HTTP or HTTPS with a port number if required.</p> <p>The status file must contain the following code:</p> <pre><?xml version="1.0" encoding="UTF-8"?> <SOAP-ENV:Envelope xmlns:SOAP-ENV="http://schemas.xmlsoap.org/soap/envelope/" xmlns:SOAP-ENC="http://schemas.xmlsoap.org/soap/encoding/" xmlns:xsi="http://www.w3.org/2001/XMLSchema-instance" xmlns:xsd="http://www.w3.org/2001/XMLSchema" <SOAP-ENV:Body> <MYCOMPANY:WebServerStatus> <MYCOMPANY:result>UP</MYCOMPANY:result></pre>

Parameter	Description
	<pre> </MYCOMPANY:WebServerStatus> </SOAP-ENV:Body> </SOAP-ENV:Envelope> Change the <MYCOMPANY:result> line to indicate the status of the server as follows: Server is UP <MYCOMPANY:result>UP</MYCOMPANY:result> Server is DOWN <MYCOMPANY:result>DOWN</MYCOMPANY:result> Do not change any other lines in the file. </pre>

Polling

The controller attempts to retrieve the server status file from the primary server first. If no response is received before the polling timeout expires (30 seconds by default), the controller attempts to retrieve the server status file from the secondary server. If no response is received before the polling timeout expires, unauthenticated users attempting to login will see the Fail page with the message: "Login server is unavailable".

After initialization, the controller continuously polls the servers to determine their status. As long as the primary server is available, it is used. If the primary server fails to respond or returns status DOWN, then the secondary server will be used, but only until the primary server comes back up.

The polling interval and polling timeout are configured by editing the following entries in the configuration file: **web-server-polling-interval** and **web-server-polling-timeout**.

To change the error message, edit the entry **err-msg-login-server-down** in `messages.txt`.

Setting the URLs of other AV-Pair values

This feature will redefine the URLs in the following AV-Pair values, if they have the same hostname as is specified for the **primary-web-server-status-url**:

- login-url
- welcome-url
- goodbye-url
- logout-url
- login-err-url
- ipass-login-url

For example, if the following values are defined:

```

primary-web-server-status-url=https://srv1.abc.com/status.html
secondary-web-server-status-url=https://srv2.abc.com/status.html
login-url=https://srv1.abc.com/loginpage.html
welcome-url=http://srv1.abc.com/mywelcome.html
login-err-url=http://srv3.xyx.com/mywelcome.html

```

- If the primary server is up, then the URLs are not changed.
- If the primary server is down and the secondary server is up, then login-url and welcome-url are changed as follows:

login-url=<https://srv2.abc.com/loginpage.html>
welcome-url=<http://srv2.abc.com/mywelcome.html>

- If both servers are down, then the URLs are not changed.

Redirect URL

The redirect-url value is used to specify the target URL for redirection when using an access list with the REDIRECT action. Only one **redirect-url** value can be specified in each controller or user RADIUS account.

When an access list rule with the REDIRECT action is processed, the users browser is redirected to a different HTTP address in this order:

- redirect-url keyword in the user account, if present
- redirect-url keyword in the controller account, if present
- login-url keyword, in the controller account, if present

The URL can contain any of the applicable placeholders defined here.

NOTE: Placeholders %G, %C, %E, %P, and %v do not produce constant values. These values may vary over time.

Use the following Colubris AV-Pair value string:

```
redirect-url=URL_of_the_page [placeholder ]
```

Where:

Parameter	Description
URL_of_the_page	URL of the redirect page. Access to the Web server hosting this page must be granted to all unauthenticated users. Do this with an appropriate access list definition.

The following placeholders can be added to the redirect-url string.

Placeholder	Description
%c	Returns the IP address of the users computer.
%l	Returns the URL on the controller where user login information should be posted for authentication. By default, this value is URL encoded. (To enable/disable URL encoding, set the value of url-encode in the <ACCESS-CONTROLLER> section in the configuration file.)
%n	Returns the NAS ID assigned to the controller. By default, this is the unit serial number. Not supported in local mode.
%s	Returns the RADIUS login name assigned to the controller. By default, this is the unit serial number. Not supported in local mode.
%o	Returns the original URL requested by the user. By default, this value is URL encoded. (To enable/disable URL encoding, set the value of url-encode in the <ACCESS-CONTROLLER> section in the configuration file.)
%i	Returns the domain name assigned to the controller Internet port.
%p	Returns the port number on the controller where user login information should be posted to for authentication.
%a	Returns the IP address of the controller interface that is sending the authentication request.
%E	When the location-aware feature is enabled, returns the ESSID of the wireless access point the user is associated with.
%P	When the location-aware feature is enabled, returns the wireless mode ("ieee802.11a", "ieee802.11b", "ieee802.11g") the user is using to communicate with the access point.

Placeholder	Description
%G	When the location-aware feature is enabled, returns the group name of the wireless access point the user is associated with.
%C	When the location-aware feature is enabled, returns the Called-station-id content for the wireless access point the user is associated with.
%r	Returns the string sent by the RADIUS server when an authentication request fails. The RADIUS server must be configured to support this feature. The information contained in the returned string depends on the configuration of the RADIUS server.
%m	Returns the MAC address of the wireless/wired client station that is being authenticated.
%v	Returns the VLAN assigned to the client station at the controller ingress.

NOTE: The maximum length of the remote login page URL is 512 characters. If this is exceeded (when using placeholders for example), the URL is truncated. It is therefore recommended that you specify the most-important placeholders first.

Example

One way to use this feature is to offer a premium service for a given (or all) sites. For example, in the controller profile, define two lists, one for normal usage and one for premium usage:

```
access-list=normal,REDIRECT,tcp,www.mypremiumservice.com,80
access-list=normal,ACCEPT,all,all,all
access-list=premium,ACCEPT,all,all,all
redirect-url=http://www.mysite.com/getpremium/
```

In the RADIUS profile for normal users, map them to the "normal" access list:

```
use-access-list=normal
```

In the RADIUS profile for premium users, map them to the "premium" access list:

```
use-access-list=premium
```

The access list only takes effect on an authentication, so a change of service as shown in this example takes effect only at the users next authentication (login).

NOC authentication

The NOC authentication feature provides a secure way of authenticating public access users, with strong mutual authentication between the login application on the Web server hosting the remote login page and the controller used for authenticating user logins. This occurs via the two Colubris AV-Pair value strings (**ssl-noc-certificate** and **ssl-noc-ca-certificate**), which define the locations of two certificates. These certificates enable the controller to validate that the user login information does indeed come from a trusted application.

For example, from a login application on the Web server.

```
ssl-noc-certificateURL_of_the_certificate
```

Certificate issued to the application on the Web server that will send user info to the controller for authentication.

```
ssl-noc-ca-certificateURL_of_the_certificate
```

Certificate of the certificate authority (CA) that issued the NOC certificate.

For a more detailed example of using NOC authentication, see [“NOC authentication” \(page 549\)](#).

HP WISPr support

WISPr login URL

This keyword lets you define the location of the WISPr login page. The controller automatically redirects users with WISPr-compatible wireless client software to this page. To customize the redirection use the WISPr redirect page keyword.

Syntax

```
wispr-login-url=URL_of_page
```

Where:

Parameter	Description
<i>URL_of_page</i>	URL of the WISPr login page.

WISPr abort login URL

This keyword lets you define the destination where the WISPr abort login will be POSTed.

Syntax

```
wispr-abort-login-url=URL_of_page
```

Where:

Parameter	Description
<i>URL_of_page</i>	URL where to POST the WISPr abort login.

WISPr redirect page

This keyword lets you define the location of the WISPr redirect page. Use this page to customize the code that the controller includes in the HTTP redirect sent to a users browser.

Syntax

```
redirect-page=URL_of_page
```

Where:

Parameter	Description
<i>URL_of_page</i>	URL of the page containing code to use for WISPr redirect.

If this keyword is not defined, default code is used. To view the default code, open the file **redirect.html**, which is available in the Public Access Examples file. See [“Sample public access pages” \(page 406\)](#).

WISPr access procedure

```
access-procedure=procedure_version
```

Where:

Parameter	Description
<i>procedure_version</i>	Specify the WISPr client access procedure supported by the controller. Currently, the controller only supports the value "1.0".

Traffic forwarding (dnat-server)

This keyword defines the external server to which the controller will forward traffic when an access list rule with the DNAT-SERVER action matches incoming traffic.

NOTE: SSL traffic cannot be forwarded as this breaks SSL security during connection negotiation resulting in the connection not being established.

Two external servers can be defined with this keyword. A status polling mechanism is available that enables the controller to determine the status of the external servers and forward traffic to the one this is operational. To activate the polling mechanism see *Multiple DNAT servers* below.

This keyword can be defined directly on the controller or in the controller RADIUS profile.

Syntax

```
dnat-server=listname, hostname, port, hostname2, port2 ]
```

Where:

Parameter	Description
<i>listname</i>	Specify the name of an access list definition that has its action set to DNAT-SERVER.
<i>hostname</i>	Specify the IP address or domain name of the primary server to which traffic will be redirected. Maximum length is 253 characters. If polling is not enabled, traffic is always sent to this server, even if it is down.
<i>port</i>	Specify the port on the primary server to which traffic will be redirected. Range: 1 to 65535.
<i>hostname2</i>	Specify the IP address or domain name of the secondary server to which traffic will be redirected. Maximum length is 253 characters. Traffic will only be sent to the secondary server if polling is enabled and the primary server is down. See “Multiple DNAT servers” (page 482) .
<i>port2</i>	Specify the port on the secondary server to which traffic will be redirected. Range: 1 to 65535.

Example

The following creates an access list called **redirect** which is used to redirect HTTP traffic for authenticated users to `server1.mycompany.com` on port 8080.

The following entry is added to the local profile for the controller:

```
access-list=redirect, DNAT-SERVER, tcp, all, 80  
dnat-server=redirect, srv1.mycompany.com, 8080
```

Multiple DNAT servers

The **dnat-server** keyword supports the definition of two external servers. To make use of these servers a polling mechanism is provided. Two keywords are available to activate and configure the polling mechanism.

Syntax

```
primary-dnat-server-status-url=listname, URL_of_page  
secondary-dnat-server-status-url=listname, URL_of_page
```

Where:

Parameter	Description
<i>listname</i>	Specify the name of an access list definition that has its action set to DNAT-SERVER.
<i>URL_of_page</i>	Specify the URL that points to a status file on the Web server. Use HTTP or HTTPS with a port number if required. The status file must contain the following code:

Parameter	Description
	<pre><?xml version="1.0" encoding="UTF-8"?> <SOAP-ENV:Envelope xmlns:SOAP-ENV="http://schemas.xmlsoap.org/soap/envelope/" xmlns:SOAP-ENC="http://schemas.xmlsoap.org/soap/encoding/" xmlns:xsi="http://www.w3.org/2001/XMLSchema-instance" xmlns:xsd="http://www.w3.org/2001/XMLSchema" xmlns:MYCOMPANY="http://www.mycompany.com/SOAP/NOCAPI/1.0/"> <SOAP-ENV:Body> <MYCOMPANY:WebServerStatus> <MYCOMPANY:result>UP</MYCOMPANY:result> <!--Change this between UP and DOWN to determine the state of your server !--> </MYCOMPANY:WebServerStatus> </SOAP-ENV:Body> </SOAP-ENV:Envelope></pre> <p>Change the</p> <pre><MYCOMPANY:result></pre> <p>line to indicate the status of the server as follows:</p> <p>Server is UP</p> <pre><MYCOMPANY:result>UP</MYCOMPANY:result></pre> <p>Server is DOWN</p> <pre><MYCOMPANY:result>DOWN</MYCOMPANY:result></pre> <p>Do not change any other lines in the file.</p> <p>If the controller fails to receive an answer to a poll, or receives an incorrect answer (bad format, wrong result setting) it is interpreted as the server being down.</p>

Polling

Initially, the controller polls the primary server at an interval of 10 minutes. As long as the primary is active, it is used. If it is not available, then the secondary server is used, but only until the primary server becomes available again.

If both servers are not available, both are polled in turn with no delay (other than the poll timeout) until one becomes available. When both servers are unavailable the access list DNAT-SERVER definition is skipped with no action taken, and processing moves to the next rule in the access list. This next rule can then be used to define the action taken when both DNAT-SERVERS are down.

The following table shows possible results when polling is active for both the primary and secondary servers.

Server 1	Server 2	Description
UP	UP	Traffic matching the DNAT-SERVER rule is forwarded to server 1.
UP	DOWN	Traffic matching the DNAT-SERVER rule is forwarded to server 1.
DOWN	UP	Traffic matching the DNAT-SERVER rule is forwarded to server 2.
DOWN	DOWN	No action is performed for the DNAT-SERVER rule. Processing moves to the next rule in the list. To accept all traffic if both servers are down, define this rule as: ACCEPT,all,all,all

Example

The following creates an access list called **redirect** which is used to redirect HTTP traffic for authenticated users to either `srv1.mycompany.com` or `srv2.mycompany.com` depending on which one is active. Port 8080 is used to forward traffic. If neither the primary or secondary DNAT-SERVER is available, all traffic is accepted.

The following entry is added to the local profile for the controller:

```
access-list=redirect, DNAT-SERVER, tcp, all, 80
access-list=redirect, ACCEPT, all, all, all
```

The following entry is added to the RADIUS profile for each user:

```
dnat-server=redirect, srv1.mycompany.com, 8080, srv2.mycompany.com, 8080
```

Colubris AV-Pair - User attribute values

User values let you define settings for individual user accounts.

Each Colubris AV-Pair value is specified using the following format:

```
<keyword>=<value>
```

The following table lists all supported user value keywords and provides a link to complete descriptions for each one.

Colubris AV-Pair keyword	For more information see
access-list	"Access list" (page 484)
ads-presentation	"Advertising" (page 485)
bandwidth-level	"Bandwidth level" (page 485)
max-output-ratemax-input-rate	"Data rate" (page 485)
one-to-one-nat	"One-to-one NAT" (page 486)
use-public-ip-subnet	"Public IP address" (page 486)
max-input-packets max-output-packets max-input-octets max-output-octets max-total-octets max-total-packets	"Quotas" (page 486)
smtp-redirect	"SMTP redirection" (page 487)
polling-arp-intervalpolling-max-arp-count	"Station polling" (page 488)
redirect-url	"Redirect URL" (page 479)
welcome-url	"Custom public access interface Web pages" (page 488)
goodbye-url	"Custom public access interface Web pages" (page 488)

Access list

An access list is a set of rules that govern how the controller controls user access to protected network resources (those attached to the controller Internet port). Access lists are defined in the profile for the controller) and are activated in user profiles as needed.

Only one access list can be activated per user profile. See ["Access list" \(page 460\)](#).

Syntax

```
use-access-list=uselistname
```

Where:

Parameter	Description
<i>uselistname</i>	Specify the name of an existing access list. This list is activated for the current user.

Advertising

Add this keyword to enable the presentation of advertising at preconfigured intervals while the user is browsing.

Syntax

`ads-presentation=value`

Where:

Parameter	Description
<i>value</i>	Set this to 1 to activate the display of advertising. Set to 0 to disable.

Bandwidth level

This keyword sets bandwidth level for a users session. The actual data rate associated with a bandwidth level is defined on the **Network > Bandwidth control** page. See [“Bandwidth levels” \(page 52\)](#). To control the default bandwidth level for all users, see [“Default user bandwidth level” \(page 473\)](#).

Syntax

`bandwidth-level=level`

Where:

Parameter	Description
<i>level</i>	Specify one of the following the bandwidth levels for the users session: VERY-HIGH HIGH NORMAL LOW

Data rate

This keyword sets the transmit and receive rates for a users session. These rates are applied on a per-user basis providing direct control of a users throughput in Kbps. Two keywords are available:

- **max-input-rate:** Controls the data rate at which traffic can be transferred from the user to the controller.
- **max-output-rate:** Controls the data rate at which traffic can be transferred from the controller to the user.

NOTE: The settings for bandwidth level always take precedence over user data rates. This means if you set a data rate which exceeds the configured bandwidth level, the rate is capped at the bandwidth level.

Syntax

```
max-output-rate=rate  
max-input-rate=rate
```

Where:

Parameter	Description
<i>rate</i>	Maximum transmit or receive speed in Kbps.

One-to-one NAT

NOTE: This feature only applies to client traffic using IPsec or PPTP on the Internet port.

Add this keyword if the user requires a unique IP address when NAT is enabled on the controller. For more information, see [“VPN one-to-one NAT” \(page 515\)](#) and [“Default user one-to-one NAT” \(page 474\)](#).

Syntax

```
one-to-one-nat=value
```

Where:

Parameter	Description
<i>value</i>	Set this to 1 to activate one-to-one NAT support.

Public IP address

Add this keyword if the user requires a public IP address that is visible on the external network connected to the controller Internet port. For more information using public IP addresses, see [“Default user public IP address” \(page 475\)](#) and [“Assigning public IP addresses” \(page 47\)](#).

Syntax

```
use-public-ip-subnet=value
```

Where:

Parameter	Description
<i>value</i>	Set this to 1 to activate assignment of a public IP address. Set to 0 to disable.

Quotas

These keywords let you define upload and download limits for each user. Limits can be defined in terms of packets or octets (bytes).

Syntax

```
max-input-packets=value  
max-output-packets=value  
max-input-octets=value  
max-output-octets=value  
max-total-octets=value  
max-total-packets=value
```

Where:

Parameter	Description
<i>value</i>	For packets: 32-bit unsigned integer value. For octets: 64-bit unsigned integer value.

When a user session is terminated based on a quota, a new non-standard termination cause is used. The value for this termination cause is 0x8744.

The text value of for the termination cause is defined in the message.txt file under the token "stat-quota-exceeded". The default value for this token is "Logged out. (Quota Exceeded.)". This value can be displayed with the ASP function `GetAuthenticationErrorMessage()`.

A series of ASP functions are available that enable you to display quota information on the session page. See [Session quotas](#).

Redirect URL

The `redirect-url` keyword is used to specify the target URL for redirection when using an access list with the REDIRECT action. Only one **redirect-url** value can be specified in a user RADIUS account. See ["Redirect URL" \(page 479\)](#).

SMTP redirection

The controller is able to provide SMTP email service on a per-user basis. This enables users to send e-mail while on the road without the restrictions imposed by most ISPs regarding the source address of outgoing mail. It works by intercepting the call to a users e-mail server and redirecting it to an SMTP server that you configure. This setting overrides the setting of ["Default user SMTP server" \(page 475\)](#).

NOTE: For mail redirection to work, the user's email server name must be publicly known. If the e-mail server name cannot be resolved, mail redirection fails.

NOTE: If an access list definition is active in the controller profile that enables unauthenticated users to access their SMTP servers, the SMTP redirect feature will not work for these users.

Syntax

```
smtp-redirect=address[:port] [,username, password]
```

Where:

Parameter	Description
<i>address</i>	Specify the IP address or domain name of the e-mail server which is used to send outgoing redirected mail.
<i>port</i>	Specify the port on the e-mail server to relay to. Range: 1 to 65535. Default: 25
<i>username</i>	Specify the username required to log on to the SMTP server. Maximum 32 characters. Only supported if the Support authentication on SMTP proxy server option is enabled on the Public access > Access control page. Works with SMTP servers that support PLAIN, CRAM-MD5, and no authentication.
<i>password</i>	Specify the password required to log on to the SMTP server. Maximum 32 characters. Only supported if the Support authentication on SMTP proxy server option is enabled on the Public access >

Parameter	Description
	Access control page. Works with SMTP servers that support PLAIN, CRAM-MD5, and no authentication.

Example 3 Proxy support on

```
smtp-redirect=smtp.mycompany.com,jimmy,letMEin
smtp-redirect=smtp.mycompany.com:8025,jimmy,letMEin
```

Example 4 Proxy support off

```
smtp-redirect=smtp.mycompany.com
smtp-redirect=smtp.mycompany.com:8025
```

Station polling

The controller continually polls authenticated client stations to ensure they are active. This feature is configured using the **Client polling** settings on the **Public access > Access control** page. If no response is received and the number of retries is reached, the client station is disconnected.

These keywords let you override the **Client polling** settings on a per-user basis.

Syntax

```
polling-arp-interval=interval
```

```
polling-max-arp-count=count
```

Where:

Parameter	Description
<i>interval</i>	Specify how long (in seconds) to wait between polls.
<i>count</i>	Specify how many polls a client station can fail to reply to before it is disconnected.

To disable polling, set both *interval* and *count* to 0.

The initial query is always done after the client station has been idle for 60 seconds. If there is no answer to this query, the settings for *polling-arp-interval* and *polling-max-arp-count* are used to control additional retries.

Custom public access interface Web pages

The following keywords let you define a custom welcome page and goodbye page on a per-user basis. These pages must be hosted on an external Web server.

- **Welcome page:** Users see this page after they are **logged in**. So, access to the Web server hosting this page must be granted to all authenticated users.
- **Goodbye page:** Users see this page after they are **logged out**. So, access to the Web server hosting this page must be granted to all unauthenticated users.

Syntax

```
welcome-url=URL_of_page [placeholder]
```

```
goodbye-url=URL_of_page [placeholder]
```

Where:

Parameter	Description
<i>URL_of_page</i>	Specify the URL of a Web page on an external Web server.
<i>placeholder</i>	Placeholder as defined in the following table.

Placeholders

By appending the following optional placeholders, you can pass important information to the Web server about the user. Server-side code can process this information to generate custom pages on-the-fly.

Placeholder	Description
<i>%l</i>	Returns the URL on the controller where user login information should be posted for authentication. This option is used with the remote login page feature. By default, this value is URL encoded. (To enable/disable URL encoding, set the value of url-encode in the <ACCESS-CONTROLLER> section in the configuration file.)
<i>%n</i>	Returns the NAS ID assigned to the controller. By default, this is the unit serial number. Not supported in local mode.
<i>%s</i>	Returns the RADIUS login name assigned to the controller. By default, this is the unit serial number.
<i>%u</i>	Returns the login name of the user.
<i>%o</i>	Returns the original URL requested by the user. By default, this value is URL encoded. (To enable/disable URL encoding, set the value of url-encode in the <ACCESS-CONTROLLER> section in the configuration file.)
<i>%i</i>	Returns the domain name assigned to the controller Internet port.
<i>%p</i>	Returns the IP port number on the controller where user login information should be posted for authentication.
<i>%a</i>	Returns the IP address of the controller Internet port.
<i>%E</i>	When the location-aware feature is enabled, returns the ESSID of the wireless AP with which the user is associated.
<i>%P</i>	When the location-aware feature is enabled, returns the wireless mode the user is using to communicate with the AP.
<i>%G</i>	When the location-aware feature is enabled, returns the group name of the wireless AP with which the user is associated.
<i>%C</i>	When the location-aware feature is enabled, returns the Called-station-id content for the wireless AP with which the user is associated.
<i>%r</i>	Returns the string sent by the RADIUS server when an authentication request fails. The RADIUS server must be configured to support this feature. The information contained in the returned string depends on the configuration of the RADIUS server.
<i>%m</i>	Returns the MAC address of the client station that is being authenticated.
<i>%v</i>	Returns the VLAN assigned to the client station at the controller ingress.

Colubris AV-Pair - Administrator attribute values

Administrator values let you define settings for administrator accounts.

Each Colubris AV-Pair value is specified using the following format: **<keyword>=<value>**

The following administrator value keyword is supported:

Administrative role

Use this AV-Pair value to identify the role of administrative accounts.

Syntax

```
web-administrative-role=role
```

Where:

Parameter	Description
<i>role</i>	Use one of the following values to identify the role of the account: <ul style="list-style-type: none">• Manager: A manager is able to access all configuration pages and can change and save all configuration settings.• Operator: An operator is able to view all configuration pages, but is limited in the types of changes that can be made.

Public access interface ASP functions and variables

The public access interface Web pages use a number of ASP functions to perform specific tasks. These ASP functions are written in embedded Javascript, which is a limited version of Javascript running on the integrated Web server.

Also, a number of ASP variables are defined that can be used to store and retrieve configuration and user settings. There are two types of variables:

- **ASP variables:** The values of these variables must be loaded before they can be used by calling the appropriate ASP function. Values are only persistent per page. Therefore they must be loaded separately on each page before use.
- **Session variables:** Session variables are persistent across all public access pages.

Javascript syntax

The following syntax is used by embedded Javascript code.

	Syntax	Description
Equality operators	==	Equal to
	!=	Not equal to
	>	Greater than
	>=	Greater than or equal to
	<	Less than
	<=	Less than or equal to
Conditional operators	&&	Conditional And
		Conditional Or
Unary operator	!	Not (Inverts the value of a boolean value.)
String operator	+	Concatenates two strings.
Arithmetic operators	+	Addition.
	-	Subtraction.
	/	Division.
	*	Multiplication.

	Syntax	Description
	()	Priority of evaluation.
Control flow	if (<i>logical condition</i>) { } else { }	If then else statement.
	for(start; until; steps) { }	Looping.

Forms

The following forms can be used to gather information from a user and submit it to the public access interface for processing.

HtmlSubscriptionRequest

This form can be used create a user account and to execute a payment.

To complete certain form actions, you may be required to submit several parameters. These parameters do not all have to be submitted at the same time. The public access interface will combine the values from multiple POSTs and execute the required task once all required data has been submitted. This allows tasks that require many user inputs (creation of a new account, for example) to be spread out over multiple pages.

Before submitting, you should clear any variable which may still be present in the session store as follows:

- `ClearSessionVar(subscription_plan)`
- `ClearSessionVar(payment_method)`
- `ClearSessionVar(password)`
- `ClearSessionVar(card_number)`
- `ClearSessionVar(card_expiration)`
- `ClearSessionVar(cart_id)`

Fields

- **cancel:** Redirects the user to `cancel_url`.
- **cancel_url:** URL to which the user is redirected when the **cancel** field is specified.
- **card_expiration:** Credit Card expiration in the format **mm/yy**.
- **card_number:** Credit Card number.
- **confirm_password:** Password of the user account.
- **error_url:** URL to which the user is redirected if an error occurs.
- **password:** Password of the user account.
- **pay:** Include this field (with any value) to execute a payment.
- **payment_method:** Payment method must be "CreditCard".
- **subscription_plan:** Name of the subscription plan.
- **success_url:** URL to which the user is redirected if no error occurs.

- **username:** Username of the user account.
- **valid_fields:** Specify the names of the fields that should be validated. Separate field names with a space. For example: valid_fields "username password confirm_password".

To create an account

Supply the following fields to create a new user account, or to reset an existing account:

- payment_method
- subscription_plan
- username
- password
- confirm_password
- valid_fields (listing all supplied fields) For example: valid_fields "payment_method subscription_plan username password confirm_password"

To execute a payment

Supply the following fields to execute a payment:

- payment_method
- subscription_plan
- username
- password
- confirmation_password
- card_expiration
- card_number
- pay
- valid_fields (listing all supplied fields) For example: valid_fields "payment_method subscription_plan username password confirm_password card_expiration card_number"

NOTE: To review payment settings, omit the pay field.

HtmlLoginRequest

This form can be used to perform several login-related actions.

Fields

- **access_type:** Determines the type of action that will be executed:
 - **login:** The **username** and **password** are used to attempt an HTML login. If the login is successful, the user is redirected to the page specified by **success_url**. If the login fails, the user is redirected to the page specified by **error_url**.
 - **subscribe:** The user is redirected to the page specified by **subscription_url**.
 - **free_access:** A user account is created (with the users MAC address as the username and password) and the user is logged into the public access interface. If the login is successful, the user is redirected to the page specified by **success_url**. If the login is fails, the user is redirected to the page specified by **error_url**.
- **error_url:** The URL to which the user is sent if the login fails. Applies to access_type = login or free_access.
- **original_url:** The URL that the user came from. Normally initialized using `GetOriginalURL()` ;

- **password:** Password to use for authentication. Applies to `access_type = login`.
- **subscription_url:** The URL to which the user is sent when `access_type = subscribe`.
- **success_url:** The URL to which the user is sent if the login is successful. Applies to `access_type = login` or `free_access`.
- **username:** Username to use for authentication. Applies to `access_type = login`.
- **valid_fields:** Name of the form fields to do validation upon.

HtmlLogout

This form performs a logout operation.

Field

- `success_url:` The URL to which the user is sent if the logout is successful.

Form errors

When the Web server validates a form, it builds a list of all fields that have validation errors. The following functions can be used to scan this list and retrieve error information for each field.

`GetLastFormSubmitFirstField()`

Returns the name of the first field (as a string) that generated a validation error. If no error occurred for any fields in the form, an empty string is returned.

Example

```
var firstField = GetLastFormSubmitFirstField();
```

`GetLastFormSubmitNextField(field_name)`

Returns the name of the next field after the specified *field_name* that generated an error. This enables you to move through the field error list one field at a time.

The field name is returned as a string. If no error occurred for any other fields in the form, an empty string is returned.

Example

```
var nextField = GetLastFormSubmitNextField("previousField");
```

`LoadFormFieldError(field_name)`

This function the following ASP variables with details about the errors caused by the specified *field_name*.

ASP variables

- ***field_error:*** Numeric error value.
 - 0 - No error found.
 - 1 - The field required a value but was empty.
 - 2 - The field contained a value which exceeds the maximum supported length.
 - 3 - The field contained a value which is invalid (only specific values were allowed).
- ***field_error_details:*** Additional information about the error. Will contain an empty string if not applicable. When *field_error* is set to 2, *field_error_details* will be equal to the maximum supported field length.

Example

```
LoadFormFieldError("field");
write(field_error);
write(field_error_details);
```

RADIUS

GetMsChapV2Failed()

Displays the MS CHAP V2 error string received in the last RADIUS Reject or RADIUS Accept packet for the user. This function is only supported if you select MSCHAP V2 as the authentication scheme on the controller (**Controller >> Authentication > RADIUS profiles** page). The RADIUS server must also support this feature. For a list of possible return values see RFC 2759.

This is not a normal return value. It cannot be assigned to an ASP variable, and is inserted directly into the HTML page.

GetRadiusNasId()

Returns the NAS ID configured for RADIUS Profile on the controller. This can be used to identify the controller that authenticated a user. For an example of how this function is used, see [GetNasAddress\(\)](#).

This is not a normal return value. It cannot be assigned to an ASP variable, and is inserted directly into the HTML page.

GetRadiusReplyMessage()

Displays the reply message content received inside the last RADIUS Request or RADIUS Accept packet for the user. The RADIUS server must be configured to support this feature. The information contained in the returned string depends on the configuration of the RADIUS server.

This is not a normal return value. It cannot be assigned to an ASP variable, and is inserted directly into the HTML page.

GetNasAddress()

Returns the fully-qualified domain name of the controller as is specified in the currently loaded SSL certificate.

For example, in certain instances you may want users to register for an account before they log in. To accomplish this you could modify the Login page by adding a register button. This redirects the users browser to a registration Web server where they can set up their account. (This page must be made accessible to non-authenticated users using the appropriate access list rule.)

To avoid having the user login once registration is complete, the registration Web server can send the user back to the controller using a special URL that automatically logs the user into the public access interface.

This is not a normal return value. It cannot be assigned to an ASP variable, and is inserted directly into the HTML page.

Example

Assuming the registration server is 192.169.30.1, the register button code on the Login page might look something like this:

```
<FORM><INPUT onclick="javascript:window.location='https://192.168.30.1/  
demo-php/register.php?  
NASip=<%GetNasAddress();%&NASid=<%GetRadiusNasId();%>';"  
type=button value="Click Here to Register">  
</FORM>
```

The NAS ID and NAS address are required when the user is redirected back to the controller after registration. The code on the registration Web page would look something like this:

```
// Registering user information in the backend database  
RegisterUser($username,  
$firstname,  
$lastname,  
$company,  
$title,  
$phone,  
$email,
```

```

$NASid, // identifies the controller the user is connected to
$NASip
);
// set URL to redirect browser to
$targetURL = "location: https://
" . $NASip . ":8090/goform/HtmlLoginRequest?
username=" . $username . "&password=" . $password;
// When done
header($targetURL);

```

The target URL is built using the NAS IP and username and password. The form name is hard-coded.

Page URLs

`GetFailRetryUrl()`

This feature has been deprecated.

Returns the URL of the next internal page to display as follows:

- Returns the Fail page URL if a login or logout request is currently pending.
- Returns the Transport page URL if the user is already logged in.

This function is designed to be used in conjunction with `IsRequestPending()`.

This is not a normal return value. It cannot be assigned to an ASP variable, and is inserted directly into the HTML page.

`GetLoginUrl()`

Returns the URL of the Login page.

This is not a normal return value, it cannot be assigned to an ASP variable, it is inserted directly into the HTML page.

`GetOriginalUrl()`

Displays the URL the user tried to access before being redirected to the Login page.

This is not a normal return value. It cannot be assigned to an ASP variable, and is inserted directly into the HTML page.

`GetSessionUrl()`

Returns the URL of the Session page.

This is not a normal return value. It cannot be assigned to an ASP variable, and is inserted directly into the HTML page.

`GetWelcomeUrl()`

Returns the URL of the Welcome page.

This is not a normal return value. It cannot be assigned to an ASP variable, and is inserted directly into the HTML page.

Session status and properties

All functions in this section do not provide a normal return value that can be assigned to an ASP variable. Instead, the return value is inserted directly into the HTML page.

Session time

`GetSessionTime()`

Returns session duration for the current user in minutes and seconds in the format: mm:ss.

`ConvertSessionTime(unit)`

Returns session duration for the current user in the specified unit. See [ConvertMaxSessionTime\(unit\)](#).

`TruncateSessionTime (unit)`

Returns session duration for the current user truncated to the specified unit. See [TruncateMaxSessionTime \(unit\)](#).

`GetSessionTimeHMS ()`

Returns session duration for the current user in hours, minutes and seconds in the format: hh:mm:ss.

`GetSessionRemainingTime ()`

Returns the amount of connection time remaining for the current user session in minutes and seconds in the format: mm:ss.

`GetSessionRemainingTimeHMS ()`

Returns the amount of connection time remaining for the current user session in hours, minutes and seconds in the format: hh:mm:ss.

`ConvertSessionRemainingTime (unit)`

Returns the total amount of connection time remaining for the current user in the specified unit. See [ConvertMaxSessionTime \(unit\)](#).

`TruncateSessionRemainingTime (unit)`

Returns the total amount of connection time remaining for the current user truncated to the specified unit. See [TruncateMaxSessionTime \(unit\)](#).

`GetMaxSessionTime ()`

Returns the total amount of connection time configured for the current user session in minutes and seconds in the format: mm:ss.

`GetMaxSessionTimeHMS ()`

Returns the total amount of connection time configured for the current user session in hours, minutes and seconds in the format: hh:mm:ss.

`ConvertMaxSessionTime (unit)`

Returns the total amount of connection time configured for the current user in the specified unit.

y	Years
d	Days
h	Hours
m	Minutes
s	Seconds

For example if the user account is configured for 5000 seconds, then:

- `ConvertMaxSessionTime("y")` returns 0, calculated as $(5000 / (365 * 24 * 60 * 60))$.
- `ConvertMaxSessionTime("d")` returns 0, calculated as $(5000 / (24 * 60 * 60))$.
- `ConvertMaxSessionTime("h")` returns 1, calculated as $(5000 / (60 * 60))$.
- `ConvertMaxSessionTime("m")` returns 83, calculated as $(5000 / 60)$.
- `ConvertMaxSessionTime("s")` returns 5000, calculated as $(5000 / 1)$.

`TruncateMaxSessionTime (unit)`

y	Years
d	Days
h	Hours

m	Minutes
s	Seconds

For example if the user account is configured for 5000 seconds, then:

- `TruncateSessionTime("y")` returns 0.
- `TruncateSessionTime("d")` returns 0.
- `TruncateSessionTime("h")` returns 1.
- `TruncateSessionTime("m")` returns 23.
- `TruncateSessionTime("s")` returns 20.

Session input/output/totals

If you specify a value for the optional parameter *div*, then the return value is divided by *div*.

`GetSessionInputPackets()`

`GetSessionInputOctets(div)`

Returns the number of packets/octetes received by the current user session.

`GetSessionOutputPackets()`

`GetSessionOutputOctets(div)`

Returns the number of packets/octetes sent by the current user session.

`GetSessionTotalPackets()`

`GetSessionTotalOctets(div)`

Returns the number of packets/octetes sent and received by the current user session.

`GetSessionMaxTotalPackets()`

`GetSessionMaxTotalOctets(div)`

Returns the maximum number of packets/octetes that can be sent and received by the current user session.

`GetSessionRemainingInputPackets()`

`GetSessionRemainingInputOctets(div)`

Returns the remaining number of packets/octetes that can be received by the current user session.

`GetSessionRemainingOutputPackets()`

`GetSessionRemainingOutputOctets(div)`

Returns the remaining number of packets/octetes that can be sent by the current user session.

`GetSessionRemainingTotalPackets()`

`GetSessionRemainingTotalOctets(div)`

Returns the remaining number of packets/octetes that can be sent or received by the current user session.

`GetSessionMaxInputPackets()`

`GetSessionMaxInputOctets(div)`

Returns the maximum number of packets/octetes that can be received by the current user session.

`GetSessionMaxOutputPackets()`

`GetSessionMaxOutputOctets(div)`

Returns the maximum number of packets/octets that can be sent by the current user session.

Session quotas

These functions let you retrieve the quota limits that are set for the current user session. If any of these limits are reached, the user is logged out. See [“Quotas” \(page 486\)](#).

If you specify a value for the optional parameter *div*, then the return value is the number of octets divided by *div*.

- Packets values are returned as a decimal string (10 characters) representing a 32-bit unsigned integer.
- Octet values are returned as a decimal string (20 characters) representing a 64-bit unsigned integer.

`GetSessionRemainingInputPackets()`

`GetSessionRemainingInputOctets(div)`

Returns the number of incoming packets/octets the current user session can still receive.

`GetSessionRemainingOutputPackets()`

`GetSessionRemainingOutputOctets(div)`

Returns the maximum number of outgoing packets/octets the current user session can still send.

`GetMaxSessionInputPackets()`

`GetMaxSessionInputOctets(div)`

Returns the maximum number of incoming packets/octets the current user session can receive.

Returns the maximum number of incoming octets the current user session can receive.

`GetMaxSessionOutputPackets()`

`GetMaxSessionOutputOctets(div)`

Returns the maximum number of outgoing packets/octets the current user session can send.

iPass support

`iPassGetLoginUrl()`

Returns the iPass Login URL.

`iPassGetAbortLoginUrl()`

Returns the iPass Abort Login URL.

`iPassGetLogoffUrl()`

Returns the iPass Logout URL.

`iPassGetRedirectResponseCode()`

Checks if the iPass authentication server is reachable and enabled. Returns one of the following values:

0	Authentication server is reachable and enabled.
105	The authentication server could not be reached or is unavailable.
255	The authentication server could not be reached due to an error on the controller (Internet port not up, for example).

`iPassGetAccessProcedure()`

Returns the access procedure supported by the controller. The controller supports procedure version 1.0.

`iPassGetLocationName()`

Returns the location ID defined on the **Public access > Access control** page.

`iPassGetAccessLocation()`

- If a user logs into a AP, this function returns the MAC address of the APs downstream port.
- If a user logs into the controller, this function returns the MAC address of the controller LAN port.

`iPassGetLoginResponseCode()`

Returns one of the following values when a user attempts to login to iPass:

50	Login was successful.
100	Login failed. Access was rejected.
102	Login failed. Authentication server error or timeout.
201	Authentication is pending.
255	The authentication server could not be reached due to an error on the controller (Internet port not up, for example).

`iPassGetLogoutResponseCode()`

Returns one of the following values when a user attempts to logout from iPass:

150	Logout was successful.
255	The authentication server could not be reached due to an error on the controller (Internet port not up, for example).

Web

`GetWebFullURL("http" | "https")`

This function returns the full URL (protocol, hostname and port) to the root of the Web server as either HTTP or HTTPS.

Example

```
var url = GetWebFullURL("http");
```

GetHTTPProtocol()

Returns the protocol used when requesting the current Web page as a string. Possible values are:

- http
- https

Example

```
var protocol = GetHTTPProtocol();
write(protocol);
/* will write either "http" or "https" depending on the URL you typed to view the page. */
```

Client information

LoadClientInformation()

This function initializes a set of variables that provide information on the user that is requesting the current page.

ASP variables

- **client_username:** String containing the username of the user if known.
- **client_useraccount_index:** String that uniquely identifies the users account.
- **client_ip_address:** String containing the IP address of the user that requested the page.
- **client_state:** The users authentication state: **1** for authenticated, **0** otherwise. If 0, all other variables will contain their last value, unless the user was never authenticated, in which case they will be blank.
- **client_session_time:** The users session time, indicating how many seconds have elapsed since the user was first authenticated by the controller. Re-authentication will not affect the value unless the authentication was terminated.
- **client_session_idle_time:** Indicates how many seconds have elapsed since the controller first received traffic from this user that was inside the user's defined access-list destination(s).
- **client_session_transmitted_packets:** Number of packets the user has transmitted to destinations inside the user's defined access-list destination(s).
- **client_session_transmitted_bytes:** Number of bytes the user has transmitted to destinations inside the user's defined access-list destination(s).
- **client_session_received_packets:** Number of packets the user has received from sources inside the user's defined access-list destination(s).
- **client_session_received_bytes:** Number of bytes the user has received from sources inside the user's defined access-list destination(s).
- **client_subscription_plan_index:** The subscription plan index with which the user account is associated. A value of **0** indicates that the user account is not associated with a plan.
- **client_authentication_mode:** Indicates how the user was authenticated:
0 - Unknown, authentication may be pending or the user is not authenticated.
1 - Authenticated using the local user accounts.
2 - Authenticated using a third-party RADIUS server.
3 - Authenticated using Active Directory.
- **client_subscription_plan_name:** Name of the subscription plan assigned to the user. Additional information can be obtained using the function `LoadSubscriptionPlanInformation()`.

- **client_subscription_plan_state:** Users subscription plan state:
0 - Plan is invalid, expired or no plan exists for that client.
1 - Plan is valid.
- **client_ads_presentation:** Users advertisement presentation state.
0 - Advertisements are enabled for the user.
1 - Advertisements are displayed for the user.
- **client_public_ip:** Indicates if the users IP address is public or private.
0 - IP address is private.
1 - IP address is public. For more information, see [“Assigning public IP addresses” \(page 47\)](#).
- **client_public_ip_reserved:** Indicates if the public IP address is reserved or preferred.
0 - Public IP is preferred.
1 - Public IP is reserved.

For more information, see [“Assigning public IP addresses” \(page 47\)](#).

`LoadClientAccountStatusInformation()`

This function initializes a set of variables that provide information on the current user.

ASP variables

- **client_account_status_is_online_time_exhausted:** Set to **1** if online time has been exhausted.
- **client_account_status_is_time_since_first_login_expired:** Set to **1** if time since first login has been exceeded its configured limit.
- **client_account_status_is_time_currently_outside_valid_period_of_day:** Set to **1** if the current time is outside the valid period for the account.
- **client_account_status_is_validity_period_not_begun:** Set to **1** if the validity period for the account has not yet begun.
- **client_account_status_is_validity_period_ended:** Set to **1** if the validity period for the account has ended.
- **client_account_status_is_input_octets_quota_exhausted:** Set to **1** if the download limit for the account has been exhausted.
- **client_account_status_is_output_octets_quota_exhausted:** Set to **1** if the upload limit for the account has been exhausted.
- **client_account_status_is_total_octets_quota_exhausted:** Set to **1** if the total traffic quota for the account has been exceeded.
- **client_account_status_first_login_time:** Time the user first logged in.
- **client_account_status_time_since_first_login:** Elapsed time since the user first logged in.
- **client_account_status_remaining_online_time:** Amount of online time remaining.
- **client_account_status_remaining_session_time:** Amount of time remaining for which the account is still valid.
- **client_account_status_expiration_time:** Date/time at which the account will expire. This is set by determining the first Validity period rule ([“Defining subscription plans” \(page 358\)](#)) that will be reached, excluding the rules that apply to time limits during a day.

- **client_account_status_remaining_input_octets**: Amount of traffic the user can still download.
- **client_account_status_remaining_output_octets**: Amount of traffic the user can still upload.
- **client_account_status_remaining_total_octets**: Total amount of traffic the user can still upload or download.
- **client_account_status_active_sessions**: Number of sessions active on this account.

Subscription plan information

`LoadSubscriptionPlanInformation(subscription_plan)`

This function initializes a set of variables that provide information on the specified subscription plan.

ASP variables

- **subscription_plan_name**: Name of the plan.
- **subscription_plan_id**: ID which uniquely identifies each subscription plan.
- **subscription_plan_fee**: Subscription plan cost.
- **subscription_plan_tax**: Subscription plan tax. Calculated based on the subscription plan cost and the configured tax rate.
- **subscription_plan_total**: Total subscription plan charge.
- **subscription_plan_description**: Description of the plan.

`GetFirstSubscriptionPlan()`

The function returns the first subscription plan name (as a string) configured on the controller for which billing is enabled.

Example

```
var plan;
for (plan = GetFirstSubscriptionPlan(); plan != ""; plan = GetNextSubscriptionPlan(plan)) {
  LoadSubscriptionPlanInformation(plan);
}
```

`GetNextSubscriptionPlan(plan_name)`

Returns the next subscription plan name that follows the specified *plan_name*. If *plan_name* is the last plan, an empty string is returned.

Example

```
var plan;
for (plan = GetFirstSubscriptionPlan(); plan != ""; plan = GetNextSubscriptionPlan(plan)) {
  LoadSubscriptionPlanInformation(plan);
}
```

Other

`AssignBillingRecordId()`

Use this function to reserve a billing record ID. If this function returns 0, it means that the payment system has been halted. Any subscription-related activities should not be attempted until this function returns a non-zero value. See [Suspend payment system when log is full of queued records](#)).

Example

```
var billingRecordId = AssignBillingRecordId();
if (billingRecordId == 0) {
  <p>The service is temporarily unavailable. Please try again later.</p>
}
```

ConditionalDisplay(*condition, state*)

This function is used to dynamically control execution of a block of code based on the value of a logical expression. An effective use for this function is to control blocks of display code, for certain features for example, that need to be turned on/off depending on user selections.

Parameters

- *Condition*: A logical embedded Javascript expression. If the expression is true, all content between the Begin and End function calls is executed.
- *State*: Indicates if this function marks the beginning or end of the block of code.
- *Begin*: Marks the beginning of the code block.
- *End*: Marks the end of the code block.

Example

```
<% ConditionalDisplay(client_state == 1, "begin"); %>
<p> Welcome to the wireless network.</p>
<% ConditionalDisplay(client_state == 1, "end"); %>
```

GetUserName()

Returns the username for the current user.

GetAuthenticationErrorMessage()

Reserved for use by `fail.asp` to display error messages for certain specific conditions. Do not use this function on other pages. Instead, use `LoadFormFieldError()` or `GetSessionVar` with the variable `last_login_error`.

IncludeAsp(*filename*)

Pauses ASP processing in the current file and continue with the specified ASP filename.

Example

```
IncludeAsp("file.asp");
```

SetSessionRefreshInterval(*sec*)

Specifies the refresh interval for the session page in seconds.

write(*string*)

Writes the specified string to the browser.

Example

```
write("<p>You are connected.</p>");
```

LoadAccessInformation()

This function initializes a set of variables that provide information on the site access options configured on the **Controller >> Public access > Web content** page.

ASP variables

- **access_free**: Set to 1 if the Free Access option is enabled.
- **access_purchase**: Set to 1 if the Allow creation of user accounts option is enabled.

Example

```
LoadAccessInformation();
if (access_free) {
<p>Welcome to your free trial of the new high-speed wireless network service.</p>
}
```

LoadPaymentInformation()

This function initializes a set of variables that provide information on the current payment services configured on the **Controller >> Public access > Payment services** page.

ASP variables

- **payment_currency:** Contains the 3-letter code identifying the currency that will be used for all transactions.
- **payment_cc_gateway:** Returns a string that identifies the payment service that is configured. Either **authorize.net** or **worldpay**.

Example

```
LoadPaymentInformation();  
if (payment_currency == "USD") {  
    write(subscription_plan_fee + " $");  
}
```

LoadWorldPayInformation()

This function initializes a set of variables that contain WorldPay-specific information.

ASP variables

- **worldpay_url:** String containing the configured WorldPay URL on the controller.
- **worldpay_installation_id:** String containing the configured WorldPay Installation ID on the controller.
- **worldpay_cart_id:** String containing a unique number for this order that represents a virtual cart in which items that are being bought are stored.

Example

```
LoadWorldPayInformation();  
write(worldpay_url);
```

LoadTaxInformation()

This function initializes a variable that provide information on the current tax setting configured on the **Controller >> Public access > Payment services** page.

ASP variable

- **tax_percent:** Tax rate that will be applied to all charges. The tax rate is configured on the controller.

Example

```
LoadTaxInformation();  
write("Tax is " + tax_percent + "% here.");
```

Session information

The controller maintains a block of data, called a session, for each IP address that is connected to the public access interface. The session makes it possible to store and access data across more than one page in the public access interface.

Session variables are reset when:

- the ASP function `ClearSessionVar()` is called
- the users session is deleted or restarted

A session ends when 3 minutes passes without any user activity on the public access interface.

Session functions

GetSessionVar(variable)

Returns the value of the specified session variable.

ClearSessionVar(variable)

Clears the value of the specified session variable.

Session variables

The following session variables are provided:

- **last_login_error:** Contains the error number generated by the last login attempt. This is converted into the appropriate visual representation by the file `login_error_messages.asp`.

Value	Description
0 or ""	No error occurred.
1	A problem occurred that caused the current login process to stop before it completed. This is normally an issue related to an administrator changing the configuration which may cause a temporary failure.
2	The login was refused by the product or external authentication server.
3	The external authentication server was unreachable.
4	There is already another login from the user in progress, so this one has been stopped.
5	The user account username/password appear to be valid, however the account is invalid due to subscription plan usage being exceeded or validity limit being exceeded.
6	The user account username/password appear to be valid, however the associated account is administratively disabled.

- **username:** Contains the username a user submitted to login or define a subscription.
- **password:** Contains the password, as a string of asterisks (**), a user submitted to login or define a subscription.
- **card_expiration:** Contains credit card expiration information in the form **mm/yy**.
- **card_number:** Contains the credit card number. The string contains all asterisks (*) with only the last four digits not hidden.
- **payment_method:** Contains the users choice for payment method: Currently only supports the value: "CreditCard".
- **subscription_plan:** This variable hold the name of the subscription plan submitted in a subscription form.
- **cart_id:** Holds the cart ID for WorldPay payments. The cart ID is automatically generated and needs to be transmitted to the WorldPay Web site via a form. See the code in **payment.asp** for an example of how to do this.
- **authorize_net_reason:** Contains a text message indicating why the Authorize.Net credit card gateway refused a payment transaction.
- **authorize_net_transaction_id:** Contains the transaction ID that the Authorize.Net credit card gateway assigned to the transaction attempt. You can display this information to the user so that they can supply this information when calling for support.
- **last_subscription_error:** Contains the error number generated by the last subscription attempt. This is converted into the appropriate visual representation by the file **subscription_error_messages.asp**.

Value	Description
0 or ""	No error occurred.
1	A problem occurred that caused the current login process to stop before it completed. This is normally an issue related to an administrator changing the configuration which may cause a temporary failure.
2	The password and confirm password fields do not match.

Value	Description
3	The wrong password was supplied for the specified username.
4	An error occurred when creating the user account.
5	The subscription plan name is invalid.
6	The credit card payment failed.
7	The credit card payment succeeded, however an error occurred when activating the user account.
8	Reserved.
9	Reserved.
10	Same as #3, but indicates that user account creation is currently not allowed.

- **last_form_error:** Contains specific errors for each field in a form. To extract this information use the ASP functions described in under ["Form errors" \(page 493\)](#).

22 Working with VPNs

Overview

Virtual private networks (VPNs) create secure tunnels across non-secure infrastructure such as the Internet or publicly-accessible networks. The controller features virtual private network (VPN) capabilities that enable it to do the following:

- Secure wireless client sessions with a VPN tunnel between wireless clients such as wireless point-of-sale (POS) terminals and the controller. IPsec, L2TP, and PPTP are all supported. (VPN tunnel represented in green.) (On the MSM720, replace **LAN port** with **Access network** and **Internet port** with **Internet network**.)

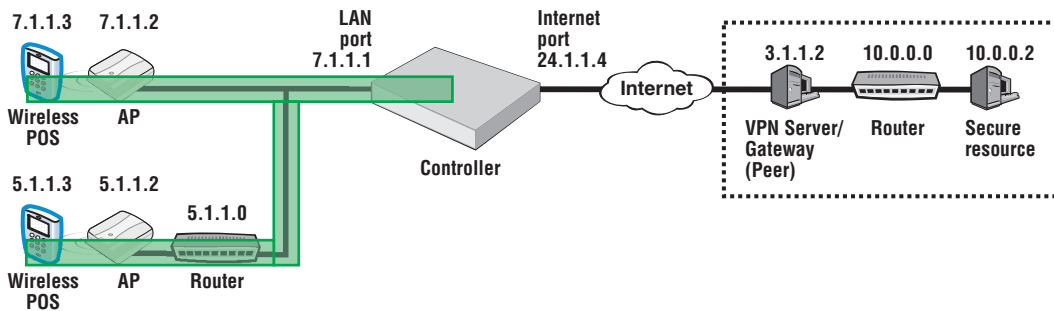

NOTE: For WPA-capable wireless clients, a better alternative to VPNs, is to extend WPA termination from the AP to the controller. See [“Terminate WPA at the controller”](#) (page 129).

- Secure controller communications to VPN servers, including both management and client traffic. For example, the controller can securely contact a remote RADIUS server for user authentication. IPsec and PPTP are supported. (VPN tunnel represented in blue.) (On the MSM720, replace **LAN port** with **Access network** and **Internet port** with **Internet network**.)

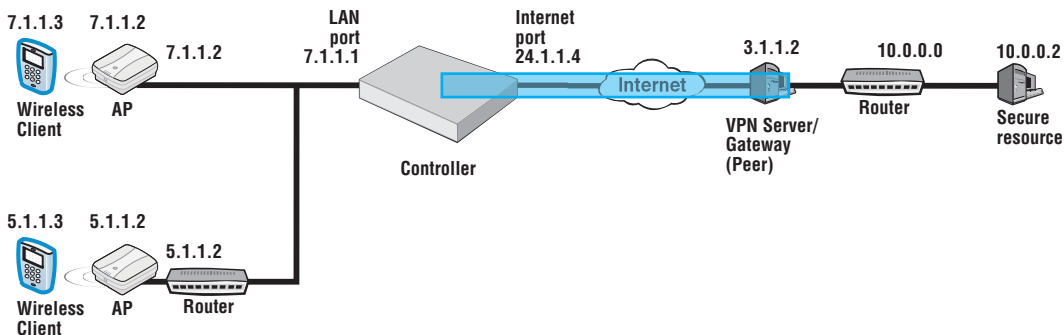

Securing wireless client sessions with VPNs

NOTE: The ability to secure wireless client sessions is intended for low-data-volume applications like that of wireless POS terminals.

To secure wireless client sessions, create a VPN tunnel from the wireless client to the controller. The sample topology seen earlier serves as an example for the sample configurations that follow. In this example, the controller LAN port has an IP address of 7.1.1.1, the APs are at 7.1.1.2 and 5.1.1.2, and the wireless POS are at 7.1.1.3 and 5.1.1.3. (On the MSM720, replace **LAN port** with **Access network** and **Internet port** with **Internet network**.)

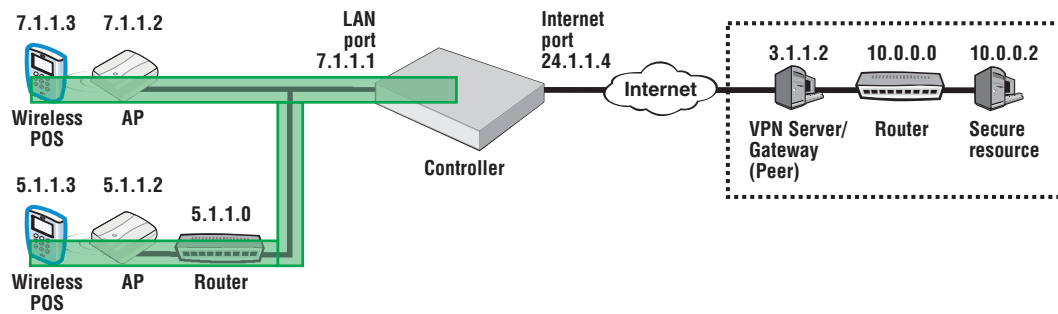

To use VPNs to secure wireless client sessions, configure an IPSec policy for this purpose, or configure the L2TP server or PPTP server.

NOTE: Wireless clients are typically assigned IP addresses from the VPN address pool. Configure this first via **Controller >> Network > Address allocation > VPN address pool**. See [“VPN address pool”](#) (page 510).

NOTE: Wireless clients require VPN software that is configured to work with your VPN configuration on the controller. If wireless clients are connected to an access-controlled VSC, enabling **VPN-based authentication** is recommended. See [“Configuring VPN-based authentication on a VSC”](#) (page 350).

Configure an IPSec profile for wireless client VPN

- On the page **Controller >> VPN > IPSec** select **Add New Policy**, and define a policy similar to this:

Note the selections made in the sample **Add/Edit security policy** page above. See the online help for option descriptions.

Option	Value to set	Notes
General	Enabled	
Name	User-defined	
Phase 1 mode	Aggressive mode	Aggressive mode requires that a group be configured.
Mode	Tunnel with Virtual IP	Allows IP addresses to be assigned to the wireless clients.
Interface	LAN port	
Encryption algorithm	Select as desired	
Perfect Forward Secrecy	Leave enabled	
Accept any peer	Enabled	Accepts any wireless client.
XAUTH > Authentication	Enabled	
Allocate address from	VPN address pool	First define address pool on Network > Address allocation .
Security policy	Subnet and Mask of <i>0.0.0.0</i>	A Subnet and Mask of 0.0.0.0. causes all wireless traffic between the client and the controller to be accepted.

Configure L2TP server for wireless client VPN

1. On the page **Controller >> VPN > L2TP server** enable **L2TP over IPsec configuration - LAN port**. (On the MSM720, replace **LAN port** with **Access network**.)

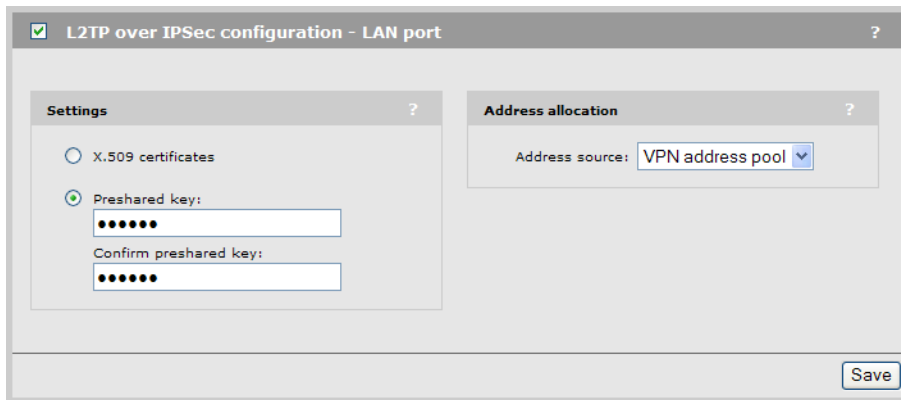

2. Either select **X.509 certificates** and install an X.509 security certificate (see [“IPsec certificates”](#) (page 381)), or specify a **Preshared key**.

NOTE: The VPN client running on the wireless device must also be configured with a matching X.509 certificate, or the **Preshared key** specified here.

3. Set **Address source** to `VPN address pool`.
See the online help for option descriptions.

Configure PPTP server for wireless client VPN

1. On the page **Controller >> VPN > PPTP server** enable **PPTP server configuration - LAN port**. (On the MSM720, replace **LAN port** with **Access network**.)

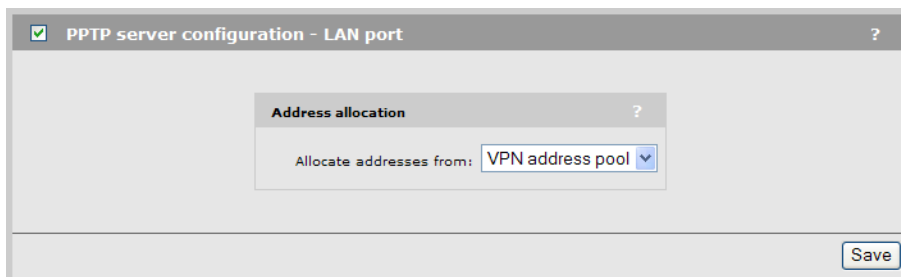

2. Set **Allocate addresses from** to `VPN address pool`. See the online help for option descriptions.

VPN address pool

When securing wireless client sessions with VPNs, it is typically necessary to provide an IP address to each client. To define a pool of addresses for this purpose, follow this procedure.

1. Select **Network > Address allocation**.
2. In **VPN address pool**, for **Address allocation** select either **Use static IP addresses** or **Use external DHCP server**.
 - For **Use static IP addresses**, define a sequential pool of addresses by specifying the **Starting IP address** and **Max connections**. For example a Starting IP address of 7.1.1.2 and a Max connections of 50, will yield a pool of IP addresses in the range 7.1.1.2 through 7.1.1.51.



- For **Use external DHCP server**, specify settings that correspond to your external DHCP server configuration. Set **Use port** to the controller port that will send out DHCP requests.

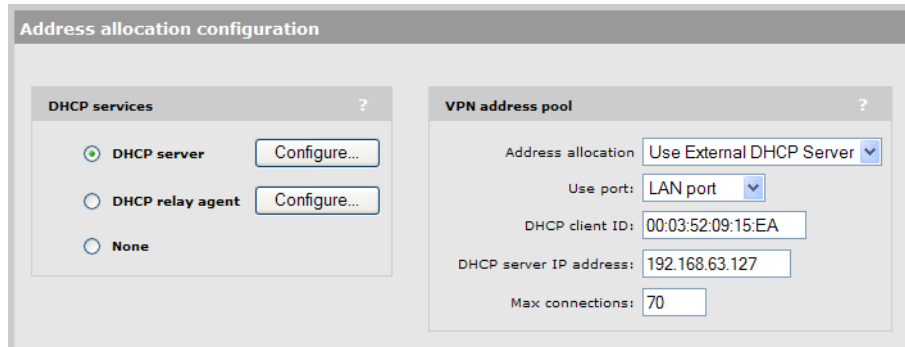

3. Select **Save**.
See the online help for option descriptions.

Securing controller communications to remote VPN servers

To secure the communications between the controller and remote VPN servers, create a VPN tunnel from the controller to the remote VPN server.

The sample topology seen earlier serves as an example for the sample configurations that follow. In this example, the controller Internet port has an IP address of 24.1.1.4, the remote VPN server is at 3.1.1.2, and the secure resource is at 10.0.0.2.

Create a VPN tunnel like this either by configuring an IPSec policy or configuring the PPTP client. (On the MSM720, replace **LAN port** with **Access network** and **Internet port** with **Internet network**.)

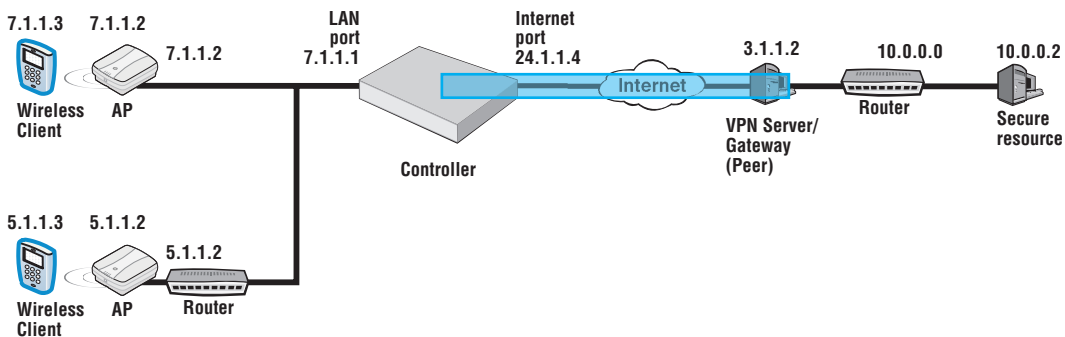

CAUTION: The VPN tunnel should not be used to transport user traffic. The tunnel should only be used to carry management traffic (RADIUS, SNMP, and management sessions). See [“Keeping user traffic out of the VPN tunnel”](#) (page 514).

Configure an IPSec policy for a remote VPN server

On the page **Controller >> VPN > IPSec** select **Add New Policy** and define a policy similar to this, substituting your own IP addresses:

Note the selections made in the sample Add/Edit security policy page above.

Option	Value to set	Notes
General	Enabled	
Name	user-defined	
Phase 1 mode	Main mode	
Mode	Tunnel	
Interface	Internet port	
Encryption algorithm	Select as desired	
Perfect Forward Security	Leave enabled	
Accept any peer	Disabled	
Peer information	User-defined	Set according to VPN server needs. In this example, the VPN server address is 3.1.1.1.
Authentication method	User-defined	Set according to VPN server needs. Either the X.509 certificates or the Preshared key must match server configuration.
Security policy > Only permit incoming...	Identify the subnet	Identify the local subnet for which you wish to filter traffic, for example,

Option	Value to set	Notes
		7.1.1.0. This must match the value defined in the policy on the peer (VPN server).
Only permit outgoing...	Identify the remote subnet	Identify the remote subnet for which you wish to filter traffic, for example, 10.0.0.0. This must match the value defined in the policy on the peer (VPN server).

See the online help for option descriptions.

See [“Keeping user traffic out of the VPN tunnel”](#) (page 514).

Configure PPTP client for a remote VPN server

Configure the PPTP client for the controller VPN client capability via the **Controller >> VPN > PPTP client** menu.

The PPTP client enables the controller to create a secure tunnel to any device that provides a PPTP server. All traffic sent through this tunnel is protected against eavesdropping by means of encryption.

NOTE: The PPTP tunnel should not be used to transport user traffic. To prevent user traffic from entering the tunnel, you must define access list definitions to DENY access to all subnets on the other side of the tunnel. The tunnel should be used to carry management traffic only (RADIUS, SNMP, management sessions). See [“Keeping user traffic out of the VPN tunnel”](#) (page 514).

Configuration

To view and configure the PPTP client, select **Controller >> VPN > PPTP client**. The PPTP client is disabled by default.

Connection

PPTP server address

Specify the domain name or IP address of the PPTP server the controller will connect to.

Domain name(s)

Specify the domain name(s) that are reachable through the tunnel. Put a space between each name as a separator. The controller routes all traffic addressed to this domain through the PPTP connection. If you do not want to enter a Domain name, enter **private.lan** instead.

Auto-route discovery

Enable this option if you want the controller to automatically discover and add routes to IP addresses on the other side of the PPTP tunnel. The addresses must be part of the specified domain. Routes are added only when an attempt is made to access the addresses.

LCP echo requests

Certain VPN servers may terminate your connection if it is idle. If you enable this option, the controller will send a packet from time to time to keep the connection alive.

Account

Username

Specify the username the controller will use to log on to the PPTP server. If you are logging on to a Windows XP domain, specify *domain_name\username*

Password / Confirm password

Specify the password the controller will use to log on to the PPTP server.

Network Address Translation (NAT)

If you enable NAT, it effectively hides the addresses of all local computers so that they are not visible on the other side of the PPTP connection.

If you disable NAT, then the appropriate IP routes must be added to send traffic through the tunnel.

Keeping user traffic out of the VPN tunnel

NOTE: The VPN tunnel should not be used to transport user traffic. The tunnel should only be used to carry management traffic (RADIUS, SNMP, and management sessions).

To prevent user traffic from entering the tunnel, you must define access list definitions to DENY access to all subnets on the other side of the tunnel.

Consider the following scenario:

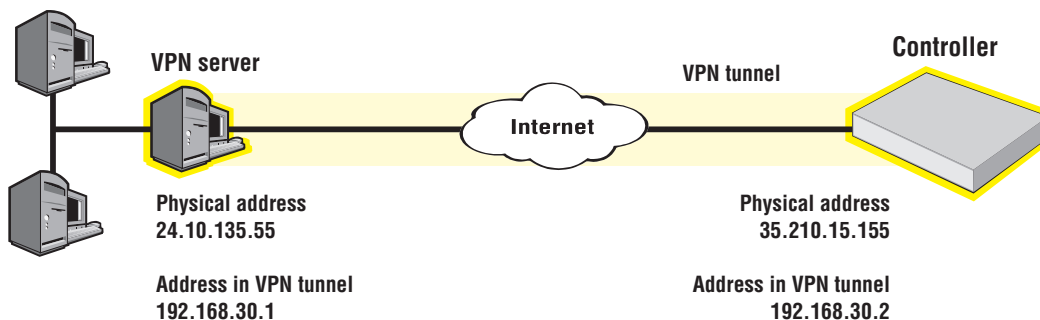

To protect the VPN, add the following definitions to the site access list:

```
access-list=vpn,DENY,all,192.168.30.0/24,all
use-access-list=vpn
```

This definition applies to all users, whether they are authenticated or not. It blocks access to the VPN subnet for all traffic. For more information on using the access list feature, see [“Access list” \(page 460\)](#).

Additional IPsec configuration

The page **Controller >> VPN > IPsec** provides some additional configuration options and information. For information about IPsec certificates see [“IPsec certificates” \(page 381\)](#).

IPsec VLAN mapping

Use these settings to define how IPsec traffic is routed on the LAN port (Access Network on the MSM720) and Internet port (Internet Network on the MSM720). For an interface to be

available, you must assign an IP address to it on the **Controller >> Network > IP interfaces** page. For example, if you create a VLAN on the Internet port, you must assign an IP address to it or it will not appear as a choice in the list.

On the MSM720, **Interface 2** can only be set to **Access Network**.

Local group list

When using IPSec aggressive mode, groups can be used to authenticate IPSec connections from clients (peers). The client must supply the group name matching one of the groups defined here to establish a security association with the controller.

Create all needed groups, providing information as follows:

- **Group name:** Group names are case-sensitive and should be in the format `user@FQDN.com` or `FQDN.com`. For example, `fred@mycompany.com` or `server99.mycompany.com`.
- **Password/Confirm password:** Passwords must be at least six characters long and contain at least four different characters.

IPSec security policy database

The **IPSec security policy database** table shows all the IPSec security policies that are defined on the controller. A security policy defines the criteria that must be met for a peer to establish an IPSec security association (SA) with the controller.

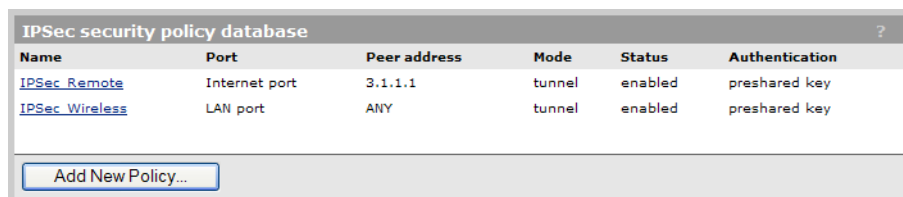

Name	Port	Peer address	Mode	Status	Authentication
IPsec Remote	Internet port	3.1.1.1	tunnel	enabled	preshared key
IPsec Wireless	LAN port	ANY	tunnel	enabled	preshared key

[Add New Policy...](#)

This information is provided:

- **Name:** Name assigned to the security policy.
- **Port:** Port assigned to the security policy.
- **Peer address:** Address of the peer which can establish an SA using this policy.
- **Mode:** Indicates the IPSec mode (tunnel or transport) supported by this policy.
- **Status:** Indicates whether the policy has been enabled. An SA can only be established when a policy is enabled.
- **Authentication:** Indicates the method used to authenticate peers.

VPN one-to-one NAT

When this feature is enabled, the controller can assign a unique IP address to each IPSec or PPTP VPN connection made by a user to a remote server via the Internet port (Internet network on the MSM720). Addresses are assigned as follows:

- On the MSM720, **Controller >> IP interfaces**. Select **Internet network** and then **Static**.
- On other controllers, **Controller >> IP interfaces**. Select **Internet port** and then **Static**.

Configure the **Additional IP addresses** option.

The address pool contains all the IP addresses that can be assigned to users. You can define up to 30 addresses. Addresses must be valid for the network to which the Internet port is connected. Specify a single address or an address range as follows: *address 1 - address 2*. For example, the following defines a range of 20 addresses: 192.168.1.1-192.168.1.20

This feature can only be used with authenticated, access-controlled users.

To reduce the number of addresses that need to be defined, the controller will use the same address for multiple users as long as they are establishing a connection with different VPN servers.

Use this feature when all of the following conditions are true:

- Users intend to make IPSec or PPTP VPN connections with a remote site via the Internet port on the controller.
- NAT is enabled on the controller. (In its default configuration, NAT translates all IP address on the local network to a single public IP address; the address assigned to the Internet port on the controller. As a result, all user sessions to an external resource appear to originate from the same IP address. This can cause a problem with remote VPN servers that require a unique IP address for each user session.)
- The remote VPN server requires that each user have a unique IP address.

NOTE: External devices cannot initiate connections with users via the address assigned by this feature.

Assigning addresses to users

To make use of this feature, each user account must have the **VPN one-to-one NAT** option enabled. Do this as follows:

- If using the local user accounts (defined on the **Controller >> Users** menu), enable the **VPN one-to-one NAT** option in the account profile or subscription plan that is assigned to the user. See [“Defining account profiles” \(page 357\)](#) and [“Defining subscription plans” \(page 358\)](#).
- If using Active Directory, enable the **VPN one-to-one NAT** option in the account profile (see [“Defining account profiles” \(page 357\)](#)) that is assigned to an Active Directory group (see [“Configuring an Active Directory group” \(page 371\)](#)).
- If using a RADIUS server, add the following Colubris AV-Pair value to the users account: `one-to-one-nat=1`. For more information on setting attributes, see [“Default user one-to-one NAT” \(page 474\)](#) and [“One-to-one NAT” \(page 486\)](#).

23 LLDP

Overview

The IEEE 802.1AB Link Layer Discovery Protocol (LLDP) provides a standards-based method for network devices to discover each other and exchange information about their capabilities. An LLDP device advertises itself to adjacent (neighbor) devices by transmitting LLDP data packets on all ports on which outbound LLDP is enabled, and reading LLDP advertisements from neighbor devices on ports that are inbound LLDP-enabled. An LLDP enabled port receiving LLDP packets inbound from neighbor devices stores the packet data in a Neighbor database (MIB).

LLDP information is used by network management tools to create accurate physical network topologies by determining which devices are neighbors and through which ports they connect.

LLDP operates at layer 2 and requires an LLDP agent to be active on each network interface that will send and receive LLDP advertisements. LLDP advertisements can contain a variable number of TLV (type, length, value) information elements. Each TLV describes a single attribute of a device.

When an LLDP agent receives information from another device, it stores it locally in a special LLDP MIB (management information base). This information can then be queried by other devices via SNMP. For example, the HP ProCurve Manager software retrieves this information to build an overview of a network and all its components.

NOTE: LLDP information is only sent/received on Ethernet links. LLDP information is not collected from wireless devices connected to an AP.

LLDP-MED

(Only supported on the HP 517 or MSM317.)

LLDP provides the base capabilities for network devices, but was not considered sufficient for IP telephony devices. As a result, in 2004, an initiative by Mitel, HP ProCurve, Avaya and Enterasys was undertaken to enhance LLDP so that it could better support IP telephony devices. The development of LLDP-Medium Endpoint Discovery (LLDP-MED) (ANSI/TIA-1057/D6) extended the LLDP standard to support advanced features on the network edge for VoIP endpoint devices with specialized capabilities and LLDP-MED standards-based functionality. The extensions to LLDP include the specification of additional TLV (Type, Length, and Value) entries specifically for VoIP management. LLDP-MED benefits include:

- Plug-and-play provisioning for MED-capable, VoIP endpoint devices.
- Simplified, vendor-independent management enabling different IP telephony systems to interoperate on one network.
- Automatic deployment of convergence network policies that includes voice VLANs, Layer2/CoS priority, and Layer 3/QoS priority.
- Configurable endpoint location data to support the Emergency Call Service (ECS) such as Enhanced 911, 999 and 112.
- Detailed VoIP endpoint data inventory readable via SNMP from the switch.
- Power over Ethernet (PoE) status and troubleshooting support via SNMP.
- Support for IP telephony network troubleshooting of call quality issues via SNMP.

LLDP-MED endpoint devices are located at the network edge and communicate using the LLDP-MED framework. Any LLDP-MED endpoint device belongs to one of the following three classes:

- Class 1 (Generic Endpoint Devices): These devices offer the basic LLDP discovery services, network policy advertisement (VLAN ID, Layer 2/802.1p priority, and Layer 3/DSCP priority),

and PoE management. This class includes such devices as IP call controllers and communication-related servers.

- Class 2 (Media Endpoint Devices): These devices offer all Class 1 features plus media streaming capability, and include such devices as voice/media gateways, conference bridges, and media servers.
- Class 3 (Communication Devices): These devices are typically IP phones or end-user devices that otherwise support IP media and offer all Class 1 and Class 2 features, plus location identification and emergency 911 capability, Layer 2 switch support, and device information management.

Local mesh

LLDP is not supported over local mesh links when running in controlled mode.

In autonomous mode, each AP only sees the APs with which it has a local mesh link as neighbors.

SNMP support

Support is provided for the following Physical Topology MIB (RFC 2922).

NOTE: When operating in controlled mode the LLDP agents on controlled APs cannot be queried via SNMP. Instead, all LLDP information from the APs is stored in the controllers MIBs.

Configuring LLDP on the controller

Controller settings are defined by selecting **Controller >> Network > Discovery protocols**.

To configure these protocols, select **Controller >> Network > Discovery protocols**.

On the MSM720

The screenshot shows the 'Discovery protocols' configuration page. On the left, the 'LLDP agent' section is configured for six ports (Port 1 to Port 6). Each port has 'Transmit' and 'Receive' checked, and a 'Configure TLVs ...' button. Below this is the 'CDP support' section, which is set to 'Disabled'. On the right, the 'LLDP settings' section includes 'Transmit interval: 30 seconds', 'Multiplier: 5', and 'Time to live: 150 seconds'. Under 'Port Description TLV content', 'Interface friendly name' is selected. The 'Generate dynamic system names' checkbox is unchecked. The 'Controller name' field shows the template '%RN-%RP-%SN', and the 'Expanded Controller name' is 'CN1ZF99057'. The 'Update AP names every' field is set to '30 seconds'. A 'Save' button is at the bottom right.

On all other controllers

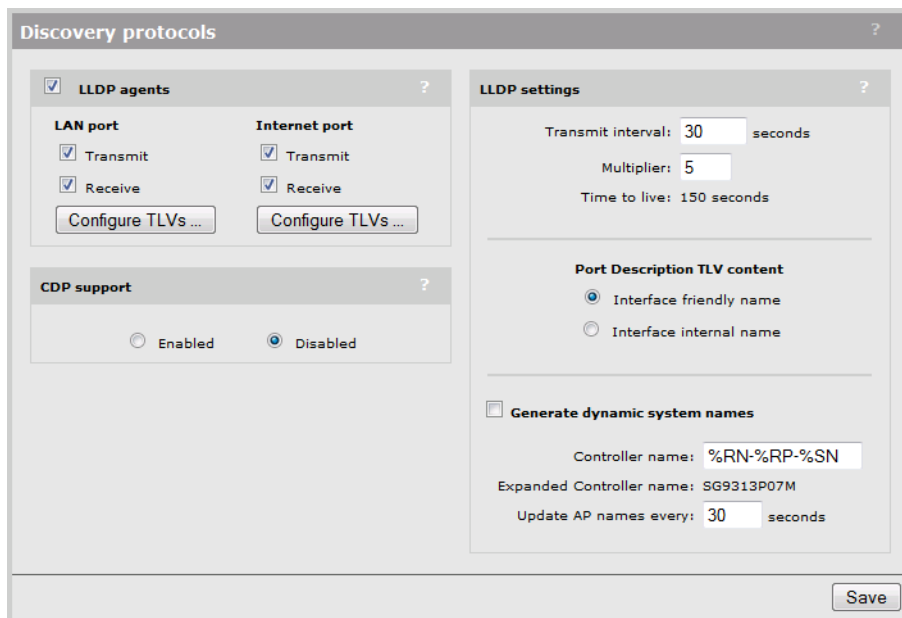

LLDP agents

Select this option to globally activate LLDP support on the controller.

LAN port / Internet port / Port 1-6

For each port, select whether the agent will transmit and/or receive LLDP information. Select **Configure TLVs** to customize TLV support for each interface.

Transmit

Enable this option to have the agent transmit LLDP information to its neighbors.

Receive

Enable this option to have the agent accept LLDP information from its neighbors.

LLDP settings

Use these options to define global LLDP settings on the controller.

Transmit interval

Sets the interval (in seconds) at which local LLDP information is updated and TLVs are sent to neighboring network devices.

Multiplier

The value of **Multiplier** is multiplied by the **Transmit interval** to define the length of **Time to live**.

Time to live

Indicates the length of time that neighbors will consider LLDP information sent by this agent to be valid. **Time to live** is automatically calculated by multiplying **Transmit interval** by **Multiplier**.

Port description TLV content

Select the content to be included in and advertised as part of the port description TLV.

Interface friendly name

Use the friendly name for the interface (the name you see in the management tool).

Interface internal name

Use the internal name for the interface. For example: eth0, eth1.

Generate dynamic system names

When enabled, this feature replaces the system name with a dynamically generated value which you can define.

Controller name

Specify how the dynamically generated name will be created. You can use regular text in combination with placeholders to create the name. Placeholders are automatically expanded each time the name is regenerated.

If the placeholders cause the generated name to exceed 32 characters, it is truncated.

Placeholders

- **%RN:** System name of the neighboring device to which the port is connected, obtained via the System Name TLV. Since this is an optional TLV, if it is not available, the Chassis ID TLV is used instead.
- **%RP:** Port description of the port on the neighboring device to which the local port is connected, obtained via the Port Description TLV. Since this is an optional TLV, if it is not available, the Port ID TLV is used instead.
- **%SN:** Controllers serial number.
- **%IP:** Controllers IP address. An IP address can require up to 15 characters (nnn.nnn.nnn.nnn).

NOTE:

- When the LLDP agent is active on both the LAN port (LAN network on the MSM720) and the Internet port (Internet network on the MSM720), the name generated on the LAN port is used for both interfaces.
- The dynamic name on the controller is only updated when a change is detected in the neighbor to which a port is connected.
- Once a system name is dynamically changed by this feature, there is no way to return to the original system name.
- To define the suffix for APs, select **Controlled APs >> Configuration > LLDP**.

Expanded controller name

Shows the generated name with all placeholders expanded. To see the generated name you must select **Save**, wait about 10 seconds, and then select the **Refresh** button in your browser.

Update AP names every *nn* seconds

Specify the interval at which dynamic names for all controlled APs are updated.

TLV settings

To customize TLV settings, select **Configure TLVs** on the **Controller >> Network > Discovery protocols** page. The same TLV settings are for all ports.

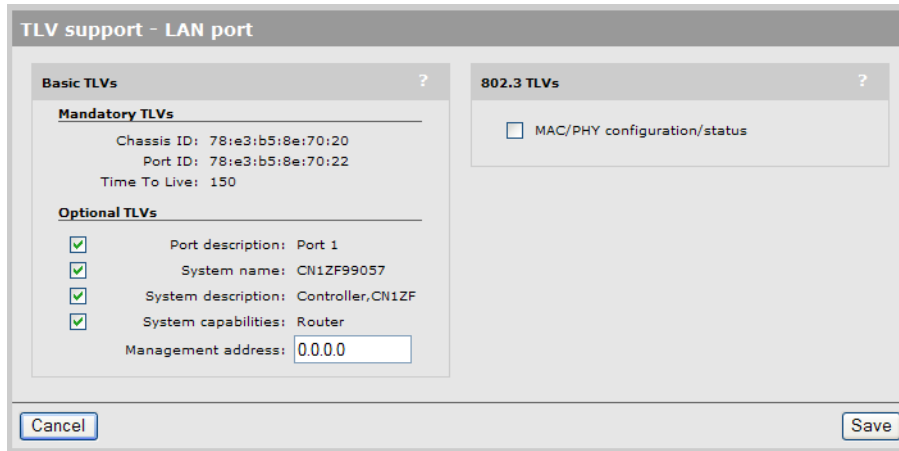

Basic TLVs

The controller supports all mandatory and optional TLVs (type, length, value) information elements that are part of the basic management set.

Mandatory TLVs

The controller always sends these TLVs with the values as shown.

- **Chassis ID** (Type 1): The MAC address of the controller.
- **Port ID** (Type 2): The MAC address of the port on which the TLV will be transmitted.
- **Time to live** (Type 3): Defines the length of time that neighbors will consider LLDP information sent by this agent to be valid. Calculated by multiplying **Transmit interval** by the **Multiplier** (as defined on the **Discovery protocols** page).

Optional TLVs

Select the optional TLVs that you want to send with the values as shown.

- **Port description** (Type 4): A description of the port.
- **System name** (Type 5): Administrative name assigned to the device from which the TLV was transmitted. By default this is the SNMP system name. If the **Generate dynamic system name** option is enabled, the system name is replaced by the dynamically generated name. The controller can only have one system name. If both the LAN and Internet ports (LAN network/Internet network on the MSM720) have active agents, then the name generated by the LAN port is used.
- **System description** (Type 6): Description of the system, comprised of the following information: hardware serial number, hardware revision number, and firmware version.
- **System capabilities** (Type 7): Indicates the primary function of the device. Set to:
 - **WLAN access point** for APs
 - **Router** for controllers.
- **Management IP address** (Type 8): The controller **always** sends a management IP address TLV containing the IP address of the port. This optional TLV lets you specify a secondary IP address on which the agent will respond to management requests. If set to 0.0.0.0, no secondary address is sent.

802.3 TLVs

The IEEE 802.3 organizationally specific TLV set is optional for all LLDP implementations. The controller supports a single optional TLV from the 802.3 definition: MAC/PHY configuration/status. This TLV provides the following information:

This TLV provides the following information:

- Bit-rate and duplex capability
- Current duplex and bit-rating
- Whether these settings were the result of auto-negotiation during link initiation or manual override.

Configuring LLDP on an AP

AP settings are defined by selecting **Controlled APs >> Configuration > LLDP**.

The screenshot shows the LLDP configuration page. The 'LLDP agent' is enabled. Under 'Media endpoint discovery (MED) features', the 'Fast Start timer' is set to 4 seconds. In the 'LLDP settings', the 'Transmit interval' is 30 seconds, the 'Multiplier' is 5, and the 'Time to live' is 150 seconds. The 'Port Description TLV content' is set to 'Interface friendly name'. The 'System name TLV content' is set to 'Access Point Name'. The 'Dynamic Name' field shows the template '%RN-%RP-%SN'. Below the main configuration, there is an 'Application type profiles' section with a table for profiles. The 'Voice' profile is shown with a VLAN ID of 1, 'Untagged' tagging, 'Normal 0' L2 priority, and '0' DiffServ. There are 'Save' buttons at the bottom of both the main configuration and the profiles section.

LLDP agent

Enable this option to activate LLDP support on the AP. When active, the agent will transmit and receive LLDP information.

When operating in controlled mode:

- The LLDP agent on an AP will not respond to SNMP requests. Therefore, local and remote MIB information is not available to external devices via the AP. Instead, this information can be retrieved from the controller.
- LLDP is not supported on local mesh links.

Supported TLVs

The LLDP agent on an AP supports the following Basic TLVs:

Mandatory TLVs

- Chassis ID (Type 1): The MAC address of the AP.
- Port ID (Type 2): The MAC address of port on which the TLV will be transmitted.
- Time to live (Type 3): Defines the length of time that neighbors will consider LLDP information sent by this agent to be valid. Calculated by multiplying **Transmit interval** by the **Multiplier**.

Optional TLVs

- Port description (Type 4): A description of the port.
- System name (Type 5): Administrative name assigned to the device from which the TLV was transmitted. By default this is the SNMP system name. If the **Dynamic name** option is enabled, the system name is replaced by the dynamically generated name.
- System description (Type 6): Description of the system, comprised of the following information: operational mode, hardware type, hardware revision, and firmware version.
- System capabilities (Type 7): Indicates the primary function of the device. Set to: **WLAN access point**.

Media endpoint discovery (MED) features

(Only supported on the HP 517 or MSM317.)

The MED LLDP extensions specify two kinds of network devices: *network connectivity* and *endpoint*. Network connectivity devices connect endpoint devices to an IEEE 802-based LAN infrastructure. This means that HP access points and controllers are network connectivity devices. Endpoint devices are located at the network edge, and include devices such as IP phones, IP media servers, and IP communication controllers.

A network connectivity device does not send LLDP-MED TLVs on any port unless it detects an endpoint device connected to the port and receives LLDP-MED TLVs from the endpoint device.

The LLDP-MED TLVs supported by HP APs are as follows:

TLV name	Description
LLDP-MED Capabilities	Indicates the supported capabilities on the device by setting the appropriate bit to 1. <ul style="list-style-type: none">• Bit 0: LLDP-MED Capabilities• Bit 1: Network Policy• Bit 2: Location Identification• Bit 3: Extended Power via MDI - PSE• Bit 4: Extended Power via MDI - PD (not supported)• Bit 5: Inventory inventory• Bits 6-15: Reserved
Network Policy	The network policy TLV is a fixed length TLV that indicates a port VLAN type, VLAN identifier (VID), and both the Layer 2 and Layer 3 priorities associated with a specific set of application types.
Location Identification	Indicates the physical location of the device using the following form: <ul style="list-style-type: none">• Emergency Call Services ELIN, as described for example by NENA TID 07-501.
Extended Power-via-MDI	Indicates the IEEE 802.1af (PoE) power related information on the device which includes: <ul style="list-style-type: none">• Power type• Power source

TLV name	Description
	<ul style="list-style-type: none"> • Power priority • Power value
MAC/PHY Configuration/Status	Indicates the following: <ul style="list-style-type: none"> • Bit-rate and duplex capability • Current duplex and bit-rating • Whether these settings were the result of auto-negotiation during link initiation or manual override

ELIN location

Emergency Call Services ELIN as described, for example, by NENA TID 07-501.

Fast Start timer

After an MED LLDPDU is received, this timer is started and the agent sends one MED LLDPDU to the MED device each second.

LLDP settings

Transmit interval

Sets the interval (in seconds) at which local LLDP information is updated and TLVs are sent to neighboring network devices.

Multiplier

The value of **Multiplier** is multiplied by the **Transmit interval** to define **Time to live**.

Time to live

Indicates the length of time that neighbors will consider LLDP information sent by this agent to be valid. **Time to live** is calculated by multiplying **Transmit interval** by **Multiplier**.

Port Description TLV content

Select the content to be included in and advertised as part of the port description TLV.

- **Interface friendly name:** Use the friendly name for the interface (the name you see in the management tool). For example: LAN port, Internet port.
- **Interface internal name:** Use the internal name for the interface. For example: eth0, eth1.

System name TLV content

Access point name

Use the name assigned to the AP as shown in the network tree. To change the name, select the AP in the network tree, and then select **Device Management > AP management**.

Dynamic Name

When the **Generate dynamic system names** option is enabled on the **Controllers >> Network > Discovery protocols** page, the system name of the AP will be replaced with a dynamically generated name that you define.

Specify how the dynamically generated name will be created. You can use regular text in combination with placeholders to create the name. Placeholders are automatically expanded each time the name is regenerated.

If the placeholders cause the generated name to exceed 32 characters, it is truncated.

-
- ❗ **IMPORTANT:** Once a system name is dynamically changed by this feature, there is no way to automatically return to the original system name.
-

Placeholders

- **%RN:** System name of the neighboring device to which the port is connected, obtained via the System Name TLV. Since this is an optional TLV, if it is not available, the Chassis ID TLV is used instead.
- **%RP:** Port description of the port on the neighboring device to which the local port is connected, obtained via the Port Description TLV. Since this is an optional TLV, if it is not available, the Port ID TLV is used instead.
- **%SN:** The AP serial number.
- **%IP:** The AP IP address. An IP address can require up to 15 characters (nnn.nnn.nnn.nnn).

Application type profiles

Application type profiles are used to define configuration settings which can be applied to the Application Type field in a Network Policy TLV on an HP 517 or MSM317 switch port.

The Network Policy TLV enables the HP 517 or MSM317 switch port to send configuration information to voice devices such as IP phones. To enable use of the Network Policy TLV, select **Controlled APs >> Configuration > Switch ports > [HP 517 or MSM317] > [switch-port]**.

Application type

This release only supports the **Voice** application type.

VLAN ID

Specify a VLAN ID for this profile. This VLAN will be assigned to the switch port.

VLAN tagging

- Tagged: The VLAN is tagged.
- Untagged: The VLAN is untagged.

L2 priority

Select the layer 2 priority setting. This setting is used instead of the **Default traffic priority** set for the switch port. Supported settings are:

L2 priority	QoS queue
Low - 1 Low - 2	4
Normal - 0 Normal - 3	3
High - 4 High - 5	2
Very high - 6 Very high - 7	1

DiffServ

This value only applies if **VLAN tagging** is set to **Tagged**.

Specify a value for the Differentiated Services codepoint (DSCP) field in IPv4 and IPv6 packet headers (as defined in RFC2474). The codepoint is composed of the six most significant bits of the DS field.

DiffServ codepoint (DSCP) value	QoS queue
> 33	1
26 - 33	2
18 - 25	3
1 - 17	4
0	Disabled

24 sFlow

Overview

sFlow **sFlow** is a technology for monitoring traffic in high speed switched or routed networks. The standard sFlow monitoring system is comprised of the following:

- An **sFlow Agent** that runs on a network device such as an AP, switch, or router. The agent uses sampling techniques to capture information about the data traffic flowing through the device and forwards this information to an sFlow collector.
- An **sFlow Collector** that receives monitoring information from sFlow agents. The collector stores this information so that a network administrator can analyze it.

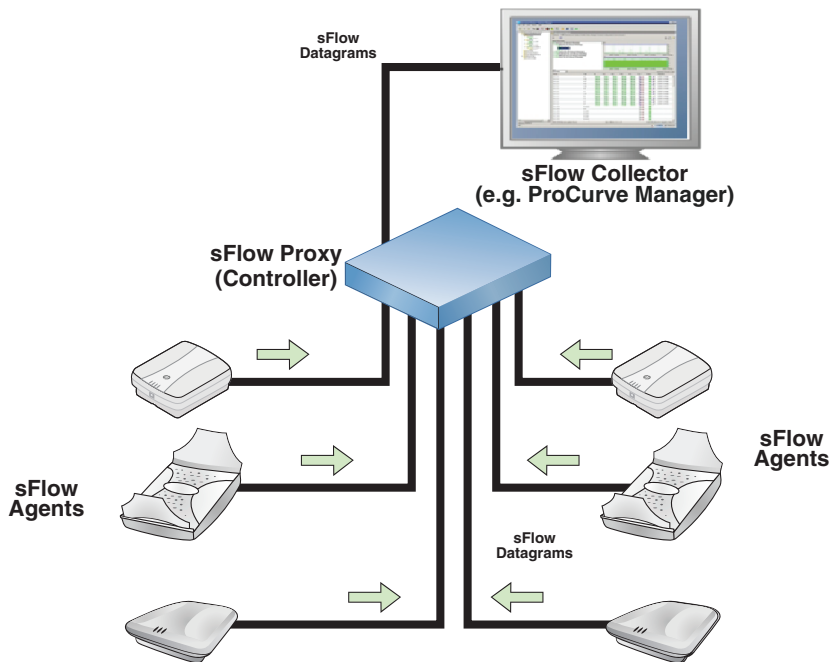

sFlow proxy

In the case of the controller and its controlled APs, the sFlow monitoring system operates slightly differently. Instead of each AP sending information directly to a collector, the APs send their information to the controller, which acts as an sFlow proxy. The controller then forwards the information to one or more collectors.

The collectors are not aware of the APs, as all sFlow information is repackaged by the controller to indicate that it is the source device. Essentially, the interfaces on the APs appear as interfaces on the controller. When the controller detects that an AP is missing, it will answer SNMP SET and GET queries from collectors with an SNMP error message.

sFlow agent support

Monitoring of sFlow traffic is supported as follows:

- **Controllers:** The controller does not generate any sFlow information of its own. The sFlow information is only generated by APs.
- **APs:** Supported only on wireless interfaces.
- **HP 517 or MSM317:** Supported on wireless interfaces and switch ports.

MIB support

The following MIBs are supported:

- sFlow-MIB base OID: 1.3.6.1.4.1.14706
- SNMP MIB2 System base OID: 1.3.6.1.2.1.1
- SNMP MIB2 Interfaces base OID: 1.3.6.1.2.1.2 Note: The ifType OID of the SNMP MIB2 Interfaces will have the value 71 (ieee802.11) for the wireless interfaces.
- SNMP MIB2 IPAddrTable base OID: 1.3.6.1.2.1.4.20
- SNMP MIB2 ifXTable base OID: 1.3.6.1.2.1.31.1.1.1
- SNMP MIB: HP-WLAN-SFLOW-EXTENSIONS-MIB base OID: 1.3.6.1.4.1.11.2.14.11.6.4.2

Configuring and activating sFlow

All sFlow configuration occurs via the controller management tool by selecting **Controller >> Tools > sFlow**.

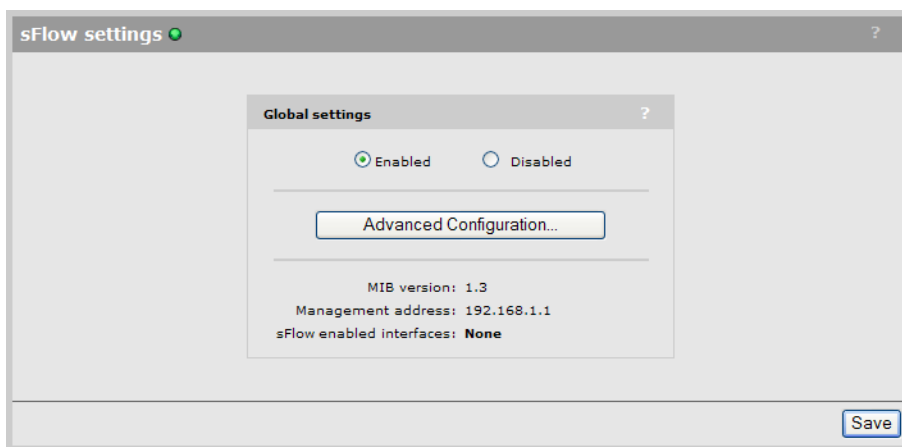

- ⓘ **IMPORTANT:** Under normal conditions, sFlow settings on the controller will be configured by an sFlow collector operating elsewhere on the network. Therefore, in most cases all you need to do to support sFlow is select the **Enabled** option under **Global settings**.

Advanced users who want to fine tune their sFlow configuration, or who are using an sFlow collector in manual mode, can select **Advanced Configuration** to gain access to additional settings.

Manual configuration of sFlow will not work with PCM, and other collectors may require special configuration to operate in this manner.

Status light

Indicates the state of the sFlow proxy.

- Red: sFlow is disabled.
- Yellow: sFlow is enabled and is in the process of starting up.
- Green: sFlow is ready.

Global settings

Enabled

Turns sFlow support on. Once enabled, sFlow agents will be activated on all controlled APs, and the agents will appear in the **Active sFlow agents** list. To see this list, select **Advanced Configuration**.

Disabled

Turns sFlow support off.

Advanced configuration

Select this button to define advanced sFlow configuration settings. Advanced configuration settings are not persistent. They are lost after a restart and are not saved when doing a configuration backup.

MIB version

Version number of the supported sFlow-MIB.

Management address

This is the IP address that a collector will use to configure sFlow. It is usually the LAN port IP address (Access network on the MSM720), or the Team IP address on a controller team.

NOTE: SNMP must be enabled on this port hosting the management address.

sFlow enabled interfaces

Displays the number of sFlow interfaces that are enabled.

To enable an interface, select **Advanced Configuration**.

Advanced sFlow configuration

This page provides access to all sFlow configuration settings, including those on controlled APs. (Configuration settings for the sFlow agents operating on an AP are also available by selecting the AP in the **Network Tree** and then selecting **Tools > sFlow**.)

The screenshot shows two sections of the configuration interface. The top section is titled "Collectors" and contains a table with the following data:

Name	IP Address	Timeout	Max datagram size	HP PMM Compatibility
[none]	[none]	0	1400	Off
[none]	[none]	0	1400	Off
[none]	[none]	0	1400	Off

Below the table is a "Done" button. The bottom section is titled "Active sFlow agents" and contains a dropdown menu for "Select the action to apply to all selected APs:" with a value of "-- Select an Action --" and an "Apply" button. Below this is another table with the following data:

AP name	MAC address	Product	Group name	Enabled interfaces
[none]	[none]	[none]	[none]	[none]

Below this table is another "Done" button.

Once sFlow support is enabled, sFlow agents will be activated on all controlled APs, and the agents will appear in the **Active sFlow agents** list.

Collectors

Up to three collectors can be configured. To configure a collector, select its name in the list. Once configured, collectors can be assigned to receive data from the sampling instances for any active sFlow agent.

The table lists the following information for each collector.

- **Name:** Name used to identify the collector.
- **IP address:** IP address of the collector. This is the address to which the controller will send sFlow data.
- **Timeout:** The time (in seconds) that the collector maintains ownership of a sampling instance.

- **Max datagram size:** The maximum number of data bytes that will be sent to the collector in a single sFlow datagram.
- **HP PMM compatibility:** When enabled, information not supported by HP PMM network management software is dropped from the sFlow data to conserve network bandwidth.

Collector configuration settings

A collector profile defines the settings that will be used to communicate with a collector.

Name

Friendly name used to identify the collector.

IP address

IP address of the collector.

Timeout

The time (in seconds) that the collector maintains ownership of a sampling instance.

- **Never expire:** Select this option to set the timeout to never expire.

Maximum datagram size

The maximum number of data bytes that will be sent to the collector in a single sample datagram.

Port

The UDP port on which sFlow data will be sent to the collector.

HP PMM compatibility

Enable this option to generate sFlow data in a format that is compatible with the HP PMM application. When enabled, information not supported by PMM is dropped from the sFlow data to conserve network bandwidth.

Active sFlow agents

Agents automatically appear in this table once sFlow support is enabled. An agent will appear for each controlled AP that is synchronized (green) under **Controlled APs** in the **Network Tree**.

- To configure the agent on an AP, select its name in the list. See [“sFlow agent settings” \(page 531\)](#).
- To sort the list based on the values in a column, select the column title.

The table lists the following information for each agent.

- **AP name:** Name assigned to the AP. By default, this is its serial number.
- **MAC address:** MAC address assigned to the AP.

- **Product:** Product name of the AP.
- **Group name:** Name of the group to which the AP is assigned.

sFlow agent settings

This page displays all data sources that are available for sampling on an AP. Each data source can support up to three configurable sampling instances.

AP: MSM410 sFlow agent configuration						
Data source	Global ifIndex	Instance	Packet flow sampling		Counter polling	
			Collector	Sampling rate	Collector	Polling interval
Port 1	32002	Instance 1	[none]	0	[none]	0
		Instance 2	[none]	0	[none]	0
		Instance 3	[none]	0	[none]	0
Wireless port	32004	Instance 1	[none]	0	[none]	0
		Instance 2	[none]	0	[none]	0
		Instance 3	[none]	0	[none]	0

Data source

Name of a port on which the sFlow agent is active.

Global ifIndex

Each port on an AP is automatically assigned a unique number starting at 32001. This uniquely identifies the port across all ports on all controlled APs. The number is available to the collectors as an ifIndex value and can be retrieved using ifIndex-related MIB elements.

Instance

Each port can support up to three instances. Each instance defines a configurable sampling process. To configure an instance, select it.

Packet flow sampling

- **Collector:** Name of the collector to which packet sampling data will be sent.
- **Sampling rate:** Defines how often samples are taken.

Counter polling

- **Collector:** Name of the collector to which counter polling data will be sent.
- **Polling interval:** Defines how often samples are taken.

Instance configuration settings

Each instance can be customized as follows:

AP: MSM410 Instance 1 configuration - Port 1	
Packet flow sampling <p>Collector: [none] ▼</p> <p>Sampling rate: 0</p> <p>Max header size: 128</p>	Counter polling <p>Collector: [none] ▼</p> <p>Polling interval: 0</p>
Cancel	Save

Packet flow sampling

Packet flow sampling is executed by copying a specified amount of data from the header of packets and sending it to a collector for analysis.

Collector

Select the collector to which data will be sent.

Sampling rate

Specify the approximate number of packets between samples. For example, if set to 5, approximately every fifth packet will be sampled (There is some jitter introduced purposefully into the sample collection). A value of 0 disables sampling.

Max header size

Specify the maximum number of bytes to copy and forward from the header of the sampled packet.

Counter polling

Counter sampling measurement are obtained by counting the number of packets and octets passing through the target interface between the defined polling interval.

Collector

Select the collector to which data will be sent.

Polling interval

Specify the amount of time (in seconds) between sending successive octet and packet counter values for this instance.

25 Working with autonomous APs

Key concepts

This chapter describes how to use the controller in conjunction with autonomous APs.



TIP: Most of this chapter applies to working with autonomous MSM APs. For third-party autonomous APs, see [“Working with third-party autonomous APs” \(page 536\)](#).

APs can operate in either controlled mode or autonomous mode. In controlled mode, the controller provides centralized management of APs. This is the preferred operation mode. See [“Working with controlled APs” \(page 145\)](#).

However, in some other cases it is necessary to operate APs in autonomous mode, for example under the following circumstances:

- When an AP is used to create a static WDS (local mesh) link. Controlled mode does not support static local mesh links. It is strongly recommended that dynamic WDS (local mesh) links be used. They provide the same capabilities but with greater flexibility. Furthermore, local mesh is supported in controlled mode.
- An AP at software version 4.x or earlier is used. Controlled mode is available on APs at software version 5.x or higher. It is strongly recommended that controllers and autonomous APs be updated to the same software version, and preferably 5.x or higher. Controlled APs are automatically updated to the controller software version.

HP recommends that you operate most MSM APs in controlled mode, reserving autonomous mode only for APs that need features unique to autonomous mode. In autonomous mode, the following features are not available: Centralized management, wireless mobility, and WPA2 Opportunistic key caching.

Autonomous AP detection

The controller automatically detects all autonomous APs that have their CDP discovery option enabled (default setting) and are installed on the same subnet as the controller.

To configure this CDP discovery, select **Network > CDP** on the AP management tool.

Viewing autonomous AP information

When the controller detects at least one autonomous AP, the **Summary** box and the **Network Tree** are updated to include autonomous AP information as follows:

Autonomous network

Autonomous APs

Summary

Controlled APs

Synchronized 3

Detected 3

Configured 3

Autonomous APs

Detected 1

Network Tree

- Service Controller
 - VSCs
 - Controlled APs
 - Autonomous APs**
 - Z008-00045

Detected Autonomous APs

Number of detected autonomous APs: 1

Device ID	Wireless MAC address	Device MAC address	IP address	Device name	Channel(s)
Z008-00045	00:03:52:04:7d:b0	00:03:52:04:7d:b0	192.168.1.12	Z008-00045	Channel 153, 5.765GHz

As shown in the above image, the **Summary** list includes a **Detected** link and count in the **Summary** list, and the **Network Tree** includes an **Autonomous APs** branch on **Controller**. These elements only appear when at least one autonomous APs has been detected. As shown, when Autonomous APs is selected, the list of **Detected Autonomous APs** list appears in the right pane.

Select a link in the **Device ID** column to display the **Autonomous APs details** like this:

Autonomous AP details

Wireless information

Device name: *(unavailable)*

Radio 1 Channel/Mode: **Channel 11, 2.462GHz/IEEE802.11b+g**

Radio 2 Channel/Mode: *(unavailable)*

Maintenance information

Platform: **MSM320**

Device ID: **B013-06369**

Firmware version: **5.2.0.0-03-5622**

Detection packet sent on: **Downstream Port**

Networking information

Wireless MAC address: **00:03:52:e0:71:60**

Bridge MAC address: **00:03:52:03:f1:d5**

IP address: **192.168.1.7**

VLAN ID: **None**

SNMP port: **161**

Secure web port: **443**

Done

You can also select the link in **IP address** column to launch the AP management tool. See the *MSM3xx/MSM4xx APs Configuration Guide*.

Switching a controlled AP to autonomous mode

To switch a controlled AP to autonomous mode, select the AP in the **Controlled APs** branch of the **Network Tree**, and then in the right pane select **Maintenance > System** and select **Switch to Autonomous Mode**.

NOTE: The AP will restart and lose all configuration settings received from the controller, returning to its default configuration. You can then configure it via its management tool.

Configuring autonomous APs

Autonomous APs must be configured via their own management tool. For convenience, you can launch an autonomous AP management tool from within the controller management tool by selecting the link in the IP address column of the Detected Autonomous APs page, providing network access is possible.

When connecting one or more autonomous APs to co-exist with a controller, some configuration issues must be addressed to ensure that data traffic and management traffic is able to flow between both devices.

If the management computer connects to the AP through the controller Internet port but the AP connects via the LAN port, static NAT mappings will be needed to be created to allow traffic to go through the controller firewall. See the *MSM3xx/MSM4xx APs Configuration Guide*.

VSC definitions

Although the controller cannot configure autonomous APs, the APs can work with the controller to benefit from the advanced access control services a controller provides. To do this, use the autonomous AP management tool to configure VSCs that use the same SSID or VLAN as already configured on the controller. The matching VSC configuration is illustrated as follows:

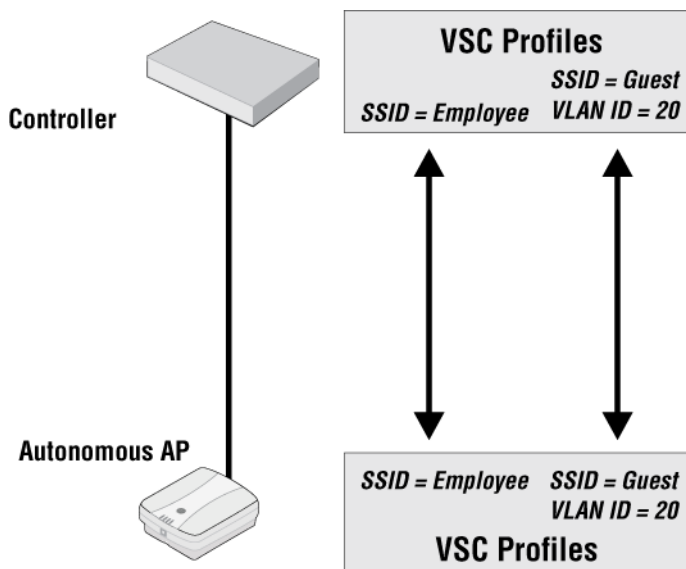

Management with VLANs

When operating in a VLAN environment, management traffic can be carried on its own VLAN. Configure the VSC on both the autonomous AP and the controller as illustrated here:

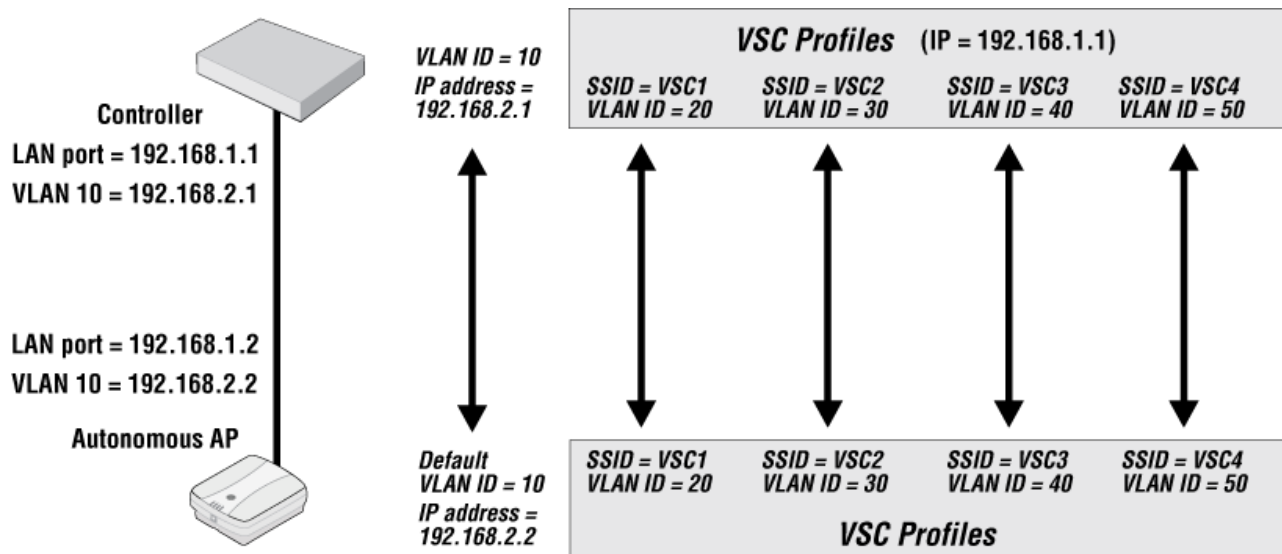

In this example, the traffic for each wireless network is carried on its own VLAN. This leaves only management traffic from the autonomous AP on VLAN 10. A static IP is assigned on both ends to permit the two devices to communicate.

Working with third-party autonomous APs

Third-party APs can be used with a controller with both access controlled and non-access-controlled VSCs.

VSC selection

User traffic from third-party APs is mapped to a VSC on the controller in the same way as for MSM APs. See [“Using multiple VSCs” \(page 138\)](#). This means that traffic is assigned to the default VSC, unless it is on a VLAN, in which case it is assigned to the VSC with matching VLAN ingress definition.

Because the HP location-aware feature is not available on third-party APs, support for VSC selection using an SSID requires that the following additional configuration be performed:

- Configure the AP to send its SSID as the NAS ID in all **authentication and accounting** requests.
- Enable the **Detect SSID from NAS-Id** option on the **Controller >> Authentication > RADIUS server** page.

RADIUS server/proxy

RADIUS server ?

Detect SSID from NAS-Id

Number of accounting sessions:

Maximum accounting sessions: 500

Authentication UDP port: 1812

Accounting UDP port: 1813

Server authentication support ?

PAP (Required to support MAC-based authentication in VSCs)

To support WPA/802.1X clients you must select at least one of the following:

- EAP-TTLS
- EAP-PEAPv0
- EAP-TLS

RADIUS authorization ?

The MSC will only reply to requests from RADIUS clients that are on this list.

--

IP address:

Mask:

Shared secret:

Default shared secret ?

Shared secret:

Confirm shared secret:

26 Maintenance

Config file management

The configuration file contains all the settings that customize the operation of the controller. You can save and restore the configuration file manually or automatically.

Select **Controller >> Maintenance > Config file management**.

The screenshot shows a web interface titled "Config file management" with a help icon (?). It is divided into four main sections:

- Backup configuration:** Contains the instruction "Backup the current configuration file." and two password input fields labeled "Password:" and "Confirm password:". A "Backup..." button is at the bottom.
- Restore configuration:** Contains the instruction "Load a configuration file." and a "Config file:" input field with a "Browse..." button. Below it is a "Password:" input field and a "Restore" button.
- Reset configuration:** Contains the instruction "Reset the configuration to factory default. NOTE: The current operational mode will be kept." and a "Reset" button.
- Scheduled operations:** A checkbox is checked. It includes a dropdown for "Operation:" (set to "Backup"), a dropdown for "Day of week:" (set to "Everyday"), and a "Time of day:" field with "00" in the "hh" (hour) and "00" in the "mm" (minute) positions. A "URL:" input field is also present. "Validate" and "Save" buttons are at the bottom.

Manual configuration file management

The following options are available for manual configuration file management.

Backup configuration

This option enables you to backup your configuration settings so they can be easily restored in case of failure. This option is also used when you want to directly edit the configuration file.

Before you install new software, you should always make a backup of your current configuration. Select **Backup** to start the process. You will be prompted for the location to place the configuration file.

Configuration information is saved in the backup file as follows:

- **Certificates and private keys:** If you specify a password when saving the configuration file, certificates and private keys are encrypted with a key based on the password. If you do not specify a password, certificates and private keys are still encrypted, but with a default key that is identical on all controllers.
- **Manager and operator username/password:** This information is not saved in the backup configuration file. This means that if you restore a configuration file, the current username and password on the controller is not overwritten.
- **All other configuration information:** All other configuration information is saved as plain text, allowing the settings to be viewed with a standard text editor.

Reset configuration

See “Resetting to factory defaults” (page 547).

Restore configuration

The **Restore configuration** option enables you to load a previously saved configuration file.

This option enables you to maintain several configuration files with different settings, which can be useful if you must frequently alter the configuration of the controller or if you are managing several controllers from a central site.

Use the following steps to restore a saved configuration file.

1. Select **Browse** and then locate the configuration file you want to restore.
2. Select **Restore** to upload it to the controller. If the configuration file is protected with a password, you must supply the password to restore the complete configuration. If you supply an invalid password, all settings are restored except for any certificates and private keys.

NOTE: The controller automatically restarts when once the file has been loaded.

Scheduled operations

The **Scheduled operations** feature enables you to schedule unattended backups or restorations of the configuration file.

Use the following steps to schedule a backup or restoration of the configuration file.

1. Select **Controller >>Maintenance > Config file management**. The **Config file management** page opens.
2. Select the **Scheduled operations** checkbox.
3. For **Operation**, select **Backup** or **Restore**.
4. For **Day of week**, select **Everyday**, or select a specific day of the week on which to perform the backup or restoration.
5. For **Time of day**, specify the hour and minute on which to perform the backup or restoration. Use the format *hh mm*, where
 - *hh* ranges from 00 to 23
 - *mm* ranges from 00 to 59
6. For **URL**, specify the path that leads to the local or remote directory in which to save the configuration file or from which to load the configuration file. For example
 - **ftp://username:password@192.168.132.11/new.cfg**
 - **http://192.168.132.11/new.cfg**Secure transfers are supported using HTTPS or FTPS.
7. Select **Validate** to test that the specified **URL** is correct.
8. Select **Save**.

Software updates

Software updates are managed by selecting **Controller >> Maintenance > Firmware updates**.

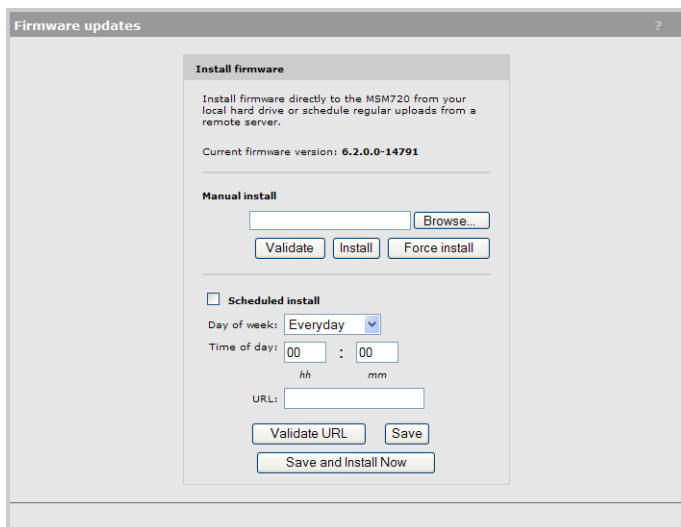

CAUTION:

- Before updating be sure to check for update issues in the Release Notes.
- Even though configuration settings are preserved during software updates, HP recommends that you backup your configuration settings before updating.
- After updating the controller software, controlled APs are automatically updated to the same version that is installed on the controller. At the end of the update process, the controller and all controlled APs automatically restart, causing all users to be disconnected. Once the controller and APs resume operation, all users must reconnect. To minimize network disruption, use the scheduled install option to have updates performed outside of peak usage hours.

Performing an immediate software update

To update the controller software now, do the following:

1. Select **Browse**, and then locate a firmware file and select it.
2. Select **Validate** if you want to test the integrity of the selected firmware file without installing it. A message will appear at the top of the page indicating whether the firmware signature is valid or invalid.
3. Select **Install**. This will automatically test the integrity of the firmware by validating its signature. If the signature is valid, the firmware will be installed and the controller will restart. If the signature is invalid, the firmware will not be installed.

NOTE: Select **Force install** to install a firmware file without validating its integrity. Installing firmware without validating its integrity may result in the controller becoming inoperative.

Performing a scheduled software update

The controller can automatically retrieve and install software from a remote site identified by its URL.

To schedule software installation, follow this procedure:

1. Enable **Scheduled install**.
2. For **Day of week**, select a specific day or **Everyday** and set **Time of day**.
3. For **URL**, specify an address like this:
 - **ftp://username:password@192.168.132.11/newsoftware.cim**
 - **http://192.168.132.11/newsoftware.cim**

Secure transfers are supported using HTTPS or FTPS.

4. Select **Validate URL** to test that the specified URL points to a firmware file.
5. Select **Save**, or to commit the schedule and also update the software immediately, select **Save and Install Now**.

NOTE: Before a scheduled software update is performed, only the first few bytes of the software file are downloaded to determine if the software is newer than the currently installed version. If it is not, the download stops and the software is not updated.

Managing licenses

Some features are optional, becoming active only when a license is installed.

To view and manage licenses, select **Controller >> Maintenance > Licenses**.

Installed licenses

This table lists all licenses that are installed on the controller.

Status

Indicates if the license is active or not.

Name

Identifies the license.

Expiration

Indicates the expiry date for the license.

Amount

Indicates the license quantity. This is set to a value of 1 for all licenses except the **Supported authenticated APs** license, which displays the total number of APs that can be managed by the controller. When no AP licenses are installed, this row displays the default capacity of the controller (10 APs on an MSM720, and 40 APs on an MSM760, MSM765 zl, and MSM775 zl). This default support cannot be deactivated or removed.

An AP license does not have to be installed to manage the MSM317. A controller can manage any number of MSM317 APs up to its controlled AP limit.

Select **Controller >> Controlled APs > AP limits**, to see a summary of AP licensing limits.

License management

Use these options to order, install, and backup license files.

License ordering information

When ordering a license file from HP you will need to supply the information displayed in this box. Once you receive your License Registration card for your purchased license, you will need to generate and install the license as described in [“Generating and installing a feature license” \(page 542\)](#).

Reset licenses

Reset the installed license to factory default configuration

Install license file

- Select **Browse** and locate the license file you received from HP.
- Select **Install License** to install the file.

Backup license file

Select **Backup** to save a backup copy of the current license file.

Generating and installing a feature license

When you purchase an optional feature license, a physical license registration card is shipped to you. License registration cards are not matched to the controller until you go to the **My Networking** portal and generate a license file for a specific device.

Once you receive your license registration card, follow this procedure to generate and install a feature license on your controller.

NOTE: When teaming is active, separate license files must be generated and individually installed on each controller that is a member of a team.

Generating a license

1. Go to www.hp.com/networking/mynetworking and sign in. New users must first create an account.
2. Select the **My Licenses** tab at the top of the page.
3. In the **Registration ID** field, type the **License Registration ID** found on your registration card. Type the ID exactly as shown, including the dashes. Select **Next**.
4. If you do not have the MAC address of your controller already on file, open its management tool in a separate Web browser window, and select **Controller >> Maintenance > Licenses**. Under **License ordering information**, copy the **MAC address** onto your clipboard. For example:

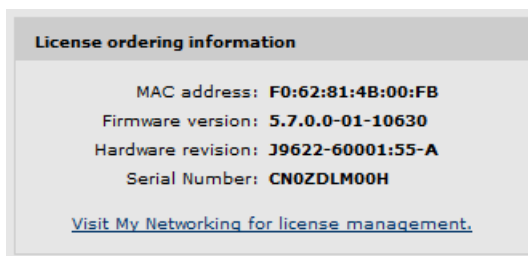

5. Back on the My Networking portal Web page, paste or type the MAC address of your controller in the **MAC Address** field. For example:

Generate license key for ProCurve device

Enter Hardware ID and click on Next button

Registration ID:	3PC464W-FQYTDK8-4GTD28C-8C8FCWJ
Product Number:	J9491A
Product Name:	HP ProCurve MSM760 Premium License
Total License Quantity:	1
Available License Quantity:	1
MAC Address:	<input type="text" value="00:1B:3F:87:43:F8"/> Help me find my MAC Address
Customer Notes (optional):	<input type="text" value="MSM760 #5"/>

Example: Closet 1080, Rack 4, Shelf 12

[« Back](#) [Next »](#)

- Optionally type a reminder for yourself in the **Customer Notes** field. Select **Next**.
- Review and accept the License Agreement. Select **Next**.

The license key is generated and made available to you for saving or sending by E-mail. For example:

The license key(s) have successfully been generated.

Select an option below to save the new license(s) information.

"Save As" - Click the "Save As" button to download the license key information to your local hard drive for archival.

[Save As »](#)

"Email" - Enter one or more email addresses, separated by comma or semi-colon, to send license(s) information for archival.

Comments:

Send email to:

[Send Email »](#)

[Generate license\(s\) »](#)

License Key:	Download License
Product Name:	HP ProCurve MSM760 Premium License
Product Number:	J9491A
Registration ID:	3PC464W-FQYTDK8-4GTD28C-8C8FCWJ
Serial Number:	Not Available
MAC Address:	00:1B:3F:87:43:F8
Status:	Active
Activation Date:	3/9/2010 7:31:40 PM
Expiration Date:	No Expiration
Customer Notes:	MSM760 #5

- Use the **Save As** button to save the license key file on your system or use **Send Email** to send the license key file and information to an E-mail address. The E-mail will contain both the license file and the license key information displayed on this page.

9. When done, select **Generate license(s)** to return to the main licenses page.

Installing a license

If you are ready to install your new license, go back to the controller management tool and do the following:

1. Select **Controller>> Maintenance > Licenses**.
2. Under **Install license file**, select **Browse** and browse to your license file. Select the file and then select **Open**.
3. Select **Install license** to complete the license installation.

27 Support and other resources

Online documentation

You can download documentation from the HP Support Center website at: www.hp.com/support/manuals. Search by product number or name.

Contacting HP

For worldwide technical support information, see the HP Support Center website: www.hp.com/networking/support

Before contacting HP, collect the following information:

- Product model names and numbers
- Technical support registration number (if applicable)
- Product serial numbers
- Error messages
- Operating system type and revision level
- Problem description and any detailed questions

HP websites





For additional information, see the following HP websites:

- www.hp.com/networking
- www.hp.com

Typographic conventions

Table 1 Document conventions

Convention	Element
Blue text: Table 1 (page 545)	Cross-reference links
Blue, underlined text: www.hp.com	Website addresses
Bold text	<ul style="list-style-type: none">• Keys that are pressed• Text typed into a GUI element, such as a box• GUI elements that are clicked or selected, such as menu and list items, buttons, tabs, and check boxes

-
-  **WARNING!** Indicates that failure to follow directions could result in bodily harm or death.
-
-  **CAUTION:** Indicates that failure to follow directions could result in damage to equipment or data.
-
-  **IMPORTANT:** Provides clarifying information or specific instructions.
-
- NOTE:** Provides additional information.
-
-  **TIP:** Provides helpful hints and shortcuts.
-

A Console ports

Overview

Console port and cable information for the MSM7xx controllers is provided in their Installation Guide.

Using the console port

The console port can be used to do the following:

- Reset the controller to factory default settings. For complete instructions, see [“Using the Console \(serial\) port” \(page 547\)](#).
- Reset the manager username and password to factory default settings. For complete instructions, see [“To reset manager credentials on a controller” \(page 546\)](#).

To reset manager credentials on a controller

1. Connect a serial cable from the serial port on your computer to the console port on the controller. (See [“Console ports” \(page 546\)](#) for information on building a serial cable to connect to your controller.)
2. Configure VT-100 terminal-emulation software on your computer as follows:
 - VT-100 (ANSI) terminal
 - Baud rate of 9600
 - 8 data bits, 1 stop bit, no parity, and no flow control
 - If on Windows, disable the **Use Function, Arrow, and Ctrl Keys for Windows** options.
 - For the Hilgrave HyperTerminal program, select the **Terminal keys** option for the **Function, arrow, and ctrl keys act as** parameter.
3. Open an appropriately-configured terminal session.
4. Power on the controller and wait for the login prompt to appear.
5. Type **emergency** and press **Enter**.
6. Type **1** and press **Enter** to reset the manager username and password.

A typical session looks like this:

```
127.0.0.1 login: emergency
-----
      Emergency Menu
-----

Device information

  Serial number: SG9603P004
    IP address: 16.90.48.186

Select one of the following options:
  1. Reset both the manager username and password to "admin"
  0. Exit
Selection: 1
Trying to reset manager login credentials....
Manager login credentials were successfully reset to:
Username = admin
Password = admin

Press any key to continue.
```

B Resetting to factory defaults

How it works

Depending on the controller model, there may be more than one way to reset the controller to its factory default settings. This appendix describes the methods available for each model type.

To reset only the manager username and password, see “[To reset manager credentials on a controller](#)” (page 546).

- △ CAUTION:** Resetting a controller to factory defaults deletes all configuration settings, resets the manager username and password to "admin," disables the DHCP server on the LAN port, sets the LAN port IP address to 192.168.1.1, and sets the Internet port to operate as a DHCP client. (The MSM765 zl and MSM775 zl ports have no factory-default IP address.)

NOTE: User-installed licenses are retained after a factory reset.

Using the reset button

On the MSM720, use the end of a paper clip to press the reset button, then press and hold the clear button for a few seconds until the front status lights blink three times.

On the MSM775 zl, insert a paper clip into the reset button hole, press the button for less than four seconds and release. To reset the controller to factory defaults, press and hold the button for more than four seconds and release. The reset button is enabled by default, but can be disabled through the switch software.

Using the management tool

Supported on models: All MSM7xx Controllers

1. Launch the management tool (default <https://192.168.1.1>).
2. Select **Controller >> Maintenance > Config file management**, and in section **Reset configuration**, select **Reset**.

The screenshot shows the 'Config file management' web interface. It is divided into four main sections:

- Backup configuration:** Includes a text input for 'Password' and another for 'Confirm password', with a 'Backup...' button below them.
- Restore configuration:** Includes a 'Manual restore' section with a 'Config file:' input, a 'Browse...' button, a 'Password:' input, and a 'Restore' button.
- Reset configuration:** Includes a 'Reset' button.
- Scheduled operations:** A checkbox labeled 'Scheduled operations' is present. Below it, there are dropdown menus for 'Operation' (set to 'Backup'), 'Day of week' (set to 'Everyday'), and 'Time of day' (set to '00 : 00').

Using the Console (serial) port

Supported on models: MSM760

NOTE: HP recommends that you use the management tool as previously described to reset a controller to factory defaults. However, if you forgot the manager username or password, you can still force factory reset as described here:

1. Power off the controller.
2. Connect a serial cable to the controller console port as follows:
 - For the MSM760, see the *MSM760 Controllers Installation Guide*.
3. Configure a communications terminal program (such as Microsoft Hyperterminal for Windows, or Minicom for Linux) as follows:
 - **Terminal:** VT-100 (ANSI)
 - **Speed:** Set speed according to the controller model:
 - For the MSM760, set speed to 9600 bps.
 - **Data bits:** 8
 - **Stop bits:** 1
 - **Parity:** *none*
 - **Flow control:** *none*
4. Open an appropriately-configured terminal session.
5. Power on the controller. System boot messages appear.
6. **Do not press any keyboard keys.** Wait for the LILO prompt to appear. It looks like this:

```
LILO 22.1 boot:
```

- ① **IMPORTANT:** As soon as the LILO prompt appears, tap the keyboard space bar to prevent the automatic (non-factory-default) boot from continuing. You must tap the space bar or other key within four seconds of the prompt appearing.
-
7. At the LILO prompt, type the command `linux factory` and press **Enter**. The boot with factory defaults begins.

C NOC authentication

Main benefits

Using a remote login page with NOC (network operations center) authentication provides you with the following benefits:

- The login page is completely customizable. You are not bound by the limits imposed by loading a login page onto the controller.
- Users can login to the public access interface without exposing their Web browsers to the SSL certificate on the controller. This eliminates warning messages caused by having an SSL certificate on the controller that is not signed by a well-known certificate authority.
- If you want to support secure login with SSL, but have multiple controllers, using a remote login page means you only need to purchase a single SSL certificate signed by a well-known certificate authority, instead of one for each access point.

How it works

The NOC authentication feature provides a secure way of authenticating public access users, with strong mutual authentication between the login application on the Web server hosting the remote login page and the controller used for authenticating user logins. This occurs via the two Colubris-AVPair value strings (**ssl-noc-certificate** and **ssl-noc-ca-certificate**), which define the locations of two certificates. These certificates enable the controller to validate that the user login information does indeed come from a trusted application. For example, from a login application on the Web server.

The following diagram shows the sequence of events for a typical user session when using the NOC-based authentication feature.

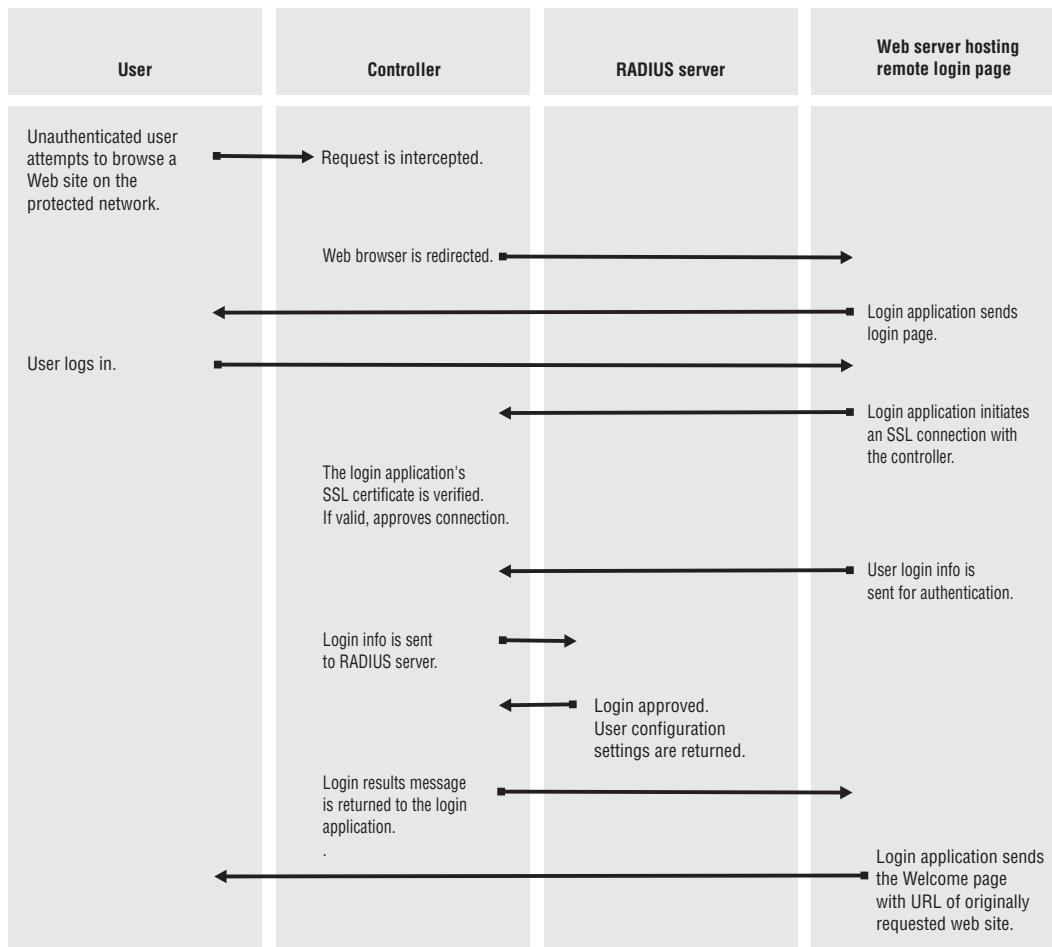

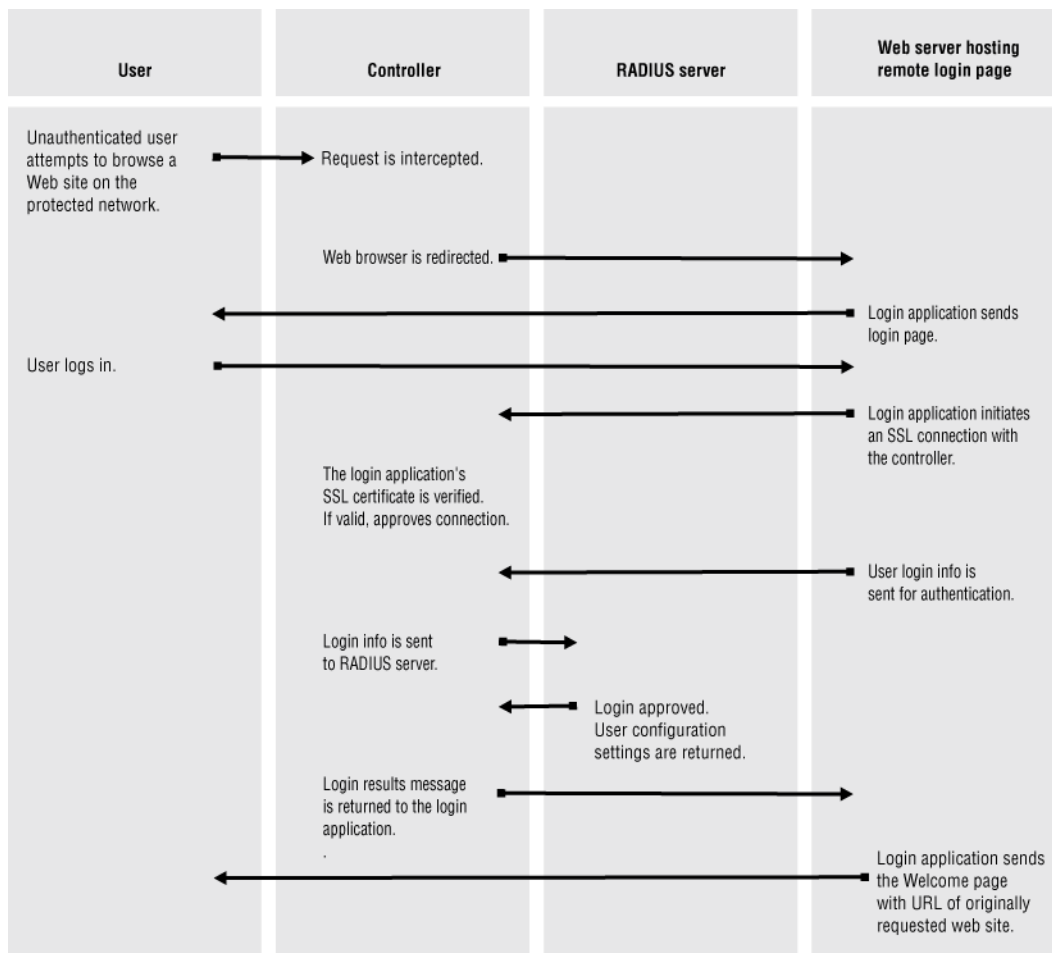

Activating a remote login page with NOC authentication

To activate a remote login page, you must define several controller attributes. These attributes can be defined in the RADIUS account for the controller (if you are using a RADIUS server) or they can be locally configured.

The following table summarizes the Colubris-AVPair value strings for the remote login page with NOC authentication.

Item	Colubris-AVPair value string
External login	<p>login-url = <i>URL_of_the_page</i> [placeholder]</p> <p>URL of the remote login page. Access to the Web server hosting this page must be granted to all unauthenticated users. Do this with an appropriate access list definition.</p>
NOC certificate	<p>ssl-noc-certificate = <i>URL_of_the_Certificate</i></p> <p>Certificate issued to the application on the Web server that sends user info to the controller for authentication.</p>
NOC CA certificate	<p>ssl-noc-ca-certificate = <i>URL_of_the_certificate</i></p> <p>Certificate of the certificate authority (CA) that issued the NOC certificate.</p>
Custom SSL certificate	<p>ssl-certificate = <i>URL_of_the_certificate</i></p> <p>Custom certificate installed on the controller.</p>

The following placeholders can be added to the login-url string.

Placeholder	Description
%C	Returns the IP address of the users computer.
%d	Returns the WISPr location-ID. Supported for login-url only.
%e	Returns the WISPr location-Name. Supported for login-url only.
%l	Returns the URL on the controller where user login information should be posted for authentication. By default, this value is URL encoded. (To enable/disable URL encoding, set the value of url-encode in the <ACCESS-CONTROLLER> section in the configuration file.)
%n	Returns the NAS ID assigned to the controller. By default, this is the units serial number. Not supported in local mode.
%s	Returns the RADIUS login name assigned to the controller. By default, this is the units serial number. Not supported in local mode.
%o	Returns the original URL requested by the user. By default, this value is URL encoded. (To enable/disable URL encoding, set the value of url-encode in the <ACCESS-CONTROLLER> section in the configuration file.)
%i	Returns the domain name assigned to the controller Internet port.
%p	Returns the port number on the controller where user login information should be posted to for authentication.
%a	Returns the IP address of the controllers interface that is sending the authentication request.
%E	When the location-aware feature is enabled, returns the ESSID of the wireless access point the user is associated with.
%P	When the location-aware feature is enabled, returns the wireless mode ("ieee802.11a", "ieee802.11b", "ieee802.11g") the user is using to communicate with the access point.
%G	When the location-aware feature is enabled, returns the group name of the wireless access point the user is associated with.
%C	When the location-aware feature is enabled, returns the Called-station-id content for the wireless access point the user is associated with.
%r	Returns the string sent by the RADIUS server when an authentication request fails. The RADIUS server must be configured to support this feature. The information contained in the returned string depends on the configuration of the RADIUS server.
%m	Returns the MAC address of the wireless/wired client station that is being authenticated.
%v	Returns the VLAN assigned to the client station at the controllers ingress.

Addressing security concerns

It is important that the connection between the login application and the controller be secure to protect the exchange of user authentication traffic. The following strategy provides for complete connection security.

Securing the remote login page

HTTPS can be used on the Web server to secure the login page. To avoid warning messages on the users browser, the SSL certificate installed on the Web server should be signed by a well-known CA.

Authenticating with the login application

The connection between the login application and the controller is secured using SSL. When establishing the SSL connection with the controller, the login application must supply its SSL certificate. In a standard SSL setup, the controller uses the CA for this certificate to validate the certificates identity and authenticate the login application.

However, the controller does not want to accept SSL connections from *just any* remote entity with a valid certificate. Rather, it only wants to accept connections from a specific entity: the login application.

To uniquely identify the login application, the *ssl-noc-certificate* attribute is defined in the RADIUS profile for the controller. This attribute contains the URL of the login applications SSL certificate. When the login application presents its SSL certificate, the controller retrieves *ssl-noc-certificate* and checks to make sure that they match.

For further authentication, a second attribute, *ssl-noc-ca-certificate*, is defined in the RADIUS profile for the controller. This attribute contains the URL of the public key of the certificate authority (CA) that signed the login applications SSL certificate. The controller uses the public key to determine if the login applications SSL certificate can be trusted.

Authenticating the controller

To identify itself, the controller uses the SSL certificate configured on the **Security > Certificate stores** page or via the *ssl-certificate* attribute.

For added security, the login application could also check that this SSL certificate has been signed by the certificate authority for which the login application has the public key certificate. The default certificate installed on the controller is not signed by a well-known CA and cannot be used for this purpose. Instead, a new certificate must be installed on the controller. This certificate could be signed by a well-known certificate authority or your own CA.

NOC authentication list

Additional security is provided via the Security list on the **Public access > Web server** page. You use this list to define the set of remote IP addresses that the controller accepts authentication requests from. If a request is received from an address not in this list, it is discarded.

Setting up the certificates

This section presents an overview of the certificates you need to install to secure communication between the remote login page and the controller. For detailed discussion of the issues, see [“Addressing security concerns” \(page 551\)](#).

Install certificates on the Web server

Install an SSL certificate and its matching CA certificate into a folder on the Web server hosting the remote login page. The login application and the controller access the certificates from this location.

The SSL certificate is used by the login application to secure communications with the controller.

Define attributes

Add the following attributes to the **Configured attributes** table on the **Public access > Attributes** page. (You can also define these attributes in the RADIUS profile for the controller if you are using a RADIUS server.) This enables it to retrieve the SSL and CA certificates from the Web server:

```
ssl-noc-certificate = URL_of_the_Certificate
```

Certificate issued to the application on the Web server that sends user info to the controller for authentication.

```
ssl-noc-ca-certificate = URL_of_the_certificate
```

Certificate of the certificate authority (CA) that issued the NOC certificate.
<code>ssl-certificate = URL_of_the_certificate</code>
Custom certificate installed on the controller.

Install a certificate on controller

NOTE: This step is optional, but recommended.

Install an SSL certificate on the controller to replace its default SSL certificate. This certificate is used to secure communications between the controller and the login application on the Web server.

If you do not change the default certificate on the controller, the login application may not be able to validate the controller certificate when establishing the SSL connection. The reason for this is because the default certificate is self-signed and is not trusted by any well-known CA.

This can be done by adding an additional attribute to the **Configured attributes** table on the **Public access > Attributes** page. (You can also define this attribute in the RADIUS profile for the controller if you are using a RADIUS server.)

`ssl-certificate = URL_of_the_certificate`

Authenticating users

After a user has supplied login information on the remote login page, the login application must submit an authentication request containing the users login name, password, and IP address to the controller by establishing an SSL session to the following URL:

`https://controller_ip:8090/goform/HtmlNocLoginRequest?username=username&password=password&ipaddr=user_ip`

Where:

Parameter	Description
<code>controller_ip</code>	<p>Defines the IP address of the controller or you could use a domain name if you have defined one using the hosts file on the Web server. (By default, the secure Web server on the controller operates on port 8090. This can be changed on the Management > Management Tool page if required.)</p> <p>The controller requires that the contents of the Host HTTP header match the actual domain name/IP address and port the controller is operating on:</p> <p>Host: <code>controller_domain_name:secure_web_server_port_number</code></p> <p>or</p> <p>Host: <code>controller_IP_address:secure_web_server_port_number</code></p> <p>This is usually the case unless the controller is behind a device that provides network address translation (NAT). In this situation, the login application must manually forge the Host HTTP header. The easiest way to do this is to define <code>login-url</code> with the <code>%i</code> and <code>%p</code> placeholders. This returns the domain name of the controller and the port number of its secure Web server. The login application can then construct the appropriate Host HTTP header.</p>
<code>username</code>	Username supplied by the user.
<code>password</code>	Password supplied by the user.
<code>user_ip</code>	IP address of the users computer.

Example 5 Example 1

Assume that the controller is not behind a NATing device, and that its IP address is 192.168.4.2. The subject DN in its SSL certificates is www.noc-cn3.com.

The Host HTTP header should be set to one of:

- Host: www.noc-cn3.com:8090
 - Host: 192.168.4.2:8090
-

Example 6 Example 2

Assume that the controller is behind a NATing device. The device has the address 192.168.30.173, and the controller has the address 192.168.4.2. A NAT mapping is defined on the NATing device that redirects traffic received on port 8090 to 192.168.4.2:8090.

The login application must send its requests to 192.168.30.173, which results in a HTTP Host header that contains one of the following:

- Host: natting.device.com:8090
- Host: 192.168.30.173:8090

When this request is forwarded to the controller, it is rejected. To solve the problem, the login application must forge the host HTTP header. This is easily done by plugging in the values returned by the `%i`, `%a`, and `%p` placeholders. For example:

Host: `%i:%p`

or

Host: `%a,%p`

The controller sends the username and password to the RADIUS server to authenticate the user. If authentication is successful, the users IP address is used to grant wireless network access to the users computer.

The controller returns a positive or negative answer for the user login, along with the relevant URLs that may be needed by the login application in order to redirect the user to either a Welcome page or a Login error page located on the Web server. This information is returned as standard HTML. The login application must parse this information to retrieve the response. All possible responses are described in the following section.

Returned values

The following examples show the information returned for various authentication conditions.

NOC authentication mode is not enabled

```
<HTML>
NOC_INFO_STATUS=NOC_STATUS_DISABLED
</HTML>
```

The controller did not receive the login applications SSL certificate

The login application did not send its certificate. Therefore, the request was rejected.

```
<HTML>
NOC_INFO_STATUS=NOC_STATUS_FAILURE
NOC_INFO_INT_ERR_MESSAGE=NOC_CANNOT_GET_PEER_CERT
</HTML>
```

Certificate mismatch

The login application sent an SSL certificate that does not match the one defined by `ssl-noc-certificate` in the RADIUS profile for the controller.

```
<HTML>
NOC_INFO_STATUS=NOC_STATUS_FAILURE
NOC_INFO_INT_ERR_MESSAGE=NOC_CANNOT_GET_PEER_CERT
</HTML>
```

Certificate not valid yet

The login application sent an SSL certificate that matches the one defined by `ssl-noc-certificate` in the RADIUS profile for the controller. However, the certificate that was sent is not yet valid.

```
<HTML>
NOC_INFO_STATUS=NOC_STATUS_FAILURE
NOC_INFO_INT_ERR_MESSAGE=NOC_CERT_NOT_YET_VALID
</HTML>
```

Certificate not valid anymore

The login application sent an SSL certificate that matches the one defined by `ssl-noc-certificate` in the RADIUS profile for the controller. However, the certificate that was sent is not valid anymore.

```
<HTML>
NOC_INFO_STATUS=NOC_STATUS_FAILURE
NOC_INFO_INT_ERR_MESSAGE=NOC_CERT_EXPIRED
</HTML>
```

Certificate not signed by proper CA

The login application sent a valid SSL certificate that matches the one defined by `ssl-noc-certificate` in the RADIUS profile for the controller. However, the certificate is not signed by the CA defined by `nocca-certificate` in the RADIUS profile for the controller.

```
<HTML>
NOC_INFO_STATUS=NOC_STATUS_FAILURE
NOC_INFO_INT_ERR_MESSAGE=NOC_CERT_NOT_SIGNED_BY_AUTHORIZED_CA
</HTML>
```

Missing username and/or password

The users username or password was not supplied.

```
<HTML>
NOC_INFO_STATUS=NOC_STATUS_FAILURE
NOC_INFO_INT_ERR_MESSAGE=NOC_MISSING_USERNAME_OR_PASSWORD
</HTML>
```

The specified IP address is already logged in

```
<HTML>
NOC_INFO_STATUS=NOC_STATUS_LOGGED_IN
</HTML>
```

Authentication was successful

```
<HTML>
NOC_INFO_STATUS=NOC_STATUS_SUCCESS
NOC_INFO_WELCOME_URL=<welcome url>
NOC_INFO_SESSION_URL=<session url>
</HTML>
```

Authentication failed

```
<HTML>
NOC_INFO_STATUS=NOC_STATUS_FAILURE
NOC_INFO_ERR_MESSAGE=<error message>
NOC_INFO_LOGIN_ERR_URL=<login error url>
</HTML>
```

Logout succeeded

```
<HTML>
NOC_INFO_STATUS=NOC_STATUS_SUCCESS
</HTML>
```

Logout failed

```
<HTML>
NOC_INFO_STATUS=NOC_STATUS_FAILURE
NOC_INFO_INT_ERR_MESSAGE=<error message>
</HTML>
```

Examples of returned HTML code

The following examples show the actual HTML code returned file for various authentication conditions.

User was successfully authenticated by the RADIUS server

```
<HTML>
status=success
welcome-url=https://206.162.167.226:8888/cebit-php/
welcome.php?site=www.noc-controller.com&user=user00&wantedurl=&nasipaddress=&nasid=L003-00069
session-url=http://192.168.1.1:8080/session.asp
</HTML>
```

Users IP address is already in use by an active session

```
<HTML>
status=already-logged-in
</HTML>
```

User authentication was refused by the RADIUS server

This could be due to an unknown username, or invalid username or password.

```
<HTML>
status=failure
external-err-msg=Your login was refused.
login-err-url=https://206.162.167.226:8888/cebit-php/login-error.php?site=john-cn3000&user=user12&
nasipaddress=
</HTML>
```

User could not be authenticated

The controller could not contact a RADIUS server.

```
<HTML>
status=failure
external-err-msg=You cannot be logged in at this time. Please try again later.
login-err-url=https://206.162.167.226:8888/cebit-php/login-error.php?site=john
-cn3000&user=user12&nasipaddress=
</HTML>
```

Simple NOC authentication example

This is a simple example showing how to use the NOC authentication feature.

1. Retrieve the Public Access Examples zip file at www.hp.com/networking/public-access-examples.
2. Create the following folder on your Web sever: **newlogin**.
3. Copy these files from the Public Access Examples zip file into the **newlogin** folder:
 - login.html
 - transport.html
 - session.html
 - fail.html
 - logo.gif
4. Customize login.html to accept username and password information from users and then send it to the controller. You could use code similar to the following PHP example to send login information back to the controller for authentication:

```
https://controller_ip:8090/goform/HtmlNocLoginRequest?username=username&password=password&ipaddress=user_ip
```

The variable *loginurl* contains the URL on the controller where user information is sent for authentication.
5. Start the management tool.
6. Select **Public access > Web server**.
7. Enable the **NOC-based authentication** feature.
8. Under **Security** add the IP address of the Web server to the **Allowed Addresses** box.
9. Under **Active interfaces** make sure that the interface on which the request will be received is enabled.
10. Select **Save**.

11. Add the following entries to the **Configured attributes** table on the **Public access > Attributes** page. (You can also define these attributes in the RADIUS profile for the controller if you are using a RADIUS server.)

```
login-url=URL_of_page_on_remote_server
access-list=loginserver,ACCEPT,tcp,web_server_IP_address, 443

ssl-noc-certificate=URL_of_the_certificate

ssl-noc-ca-certificate=URL_of_the_certificate

transport-page=web_server_URL /newlogin/transport.html

session-page=web_server_URL /newlogin/session.html

fail-page=web_server_URL /newlogin/fail.html

logo=web_server_URL /newlogin/logo.gif

use-access-list=loginserver
```

Forcing user logouts

Users can be logged out by calling the following URL:

https://controller_ip:8090/goform/HtmlNocLogoutRequest?ipaddress=user_ip

NOTE: This request must come from the login application (or another other application that is using the same SSL certificate).

The controller returns a positive or negative answer for the user logout as standard HTML. The login application must parse this information to retrieve the response.

Logout success

```
<HTML>
NOC_INFO_STATUS=NOC_STATUS_SUCCESS
</HTML>
```

Logout failure

```
<HTML>
NOC_INFO_STATUS=NOC_STATUS_FAILURE
NOC_INFO_INT_ERR_MESSAGE=<error message>
</HTML>
```

These definitions are contained in **noc.h**.

D DHCP servers and Colubris vendor classes

Overview

This section shows you how to configure the following DHCP servers to use the vendor-specific class:

- “Windows Server 2003 configuration” (page 558).
- “ISC DHCP server configuration” (page 562).

A vendor class allows certain devices to request specific information from a Dynamic Host Configuration Protocol server. Specifically, the HP ProCurve vendor class enables you to define a list of available controllers to which APs operating in controlled mode can connect.

When DHCP clients send the Colubris *vendor class identifier* in a DHCP request, a properly configured DHCP server returns the Colubris-specific options defined on the server. These values are returned as DHCP option 43 (vendor-specific information) and can be interpreted only by a HP ProCurve device.

Windows Server 2003 configuration

This section describes how to configure a Windows 2003 DHCP server to use the HP ProCurve vendor class.

The following procedure assumes that you have a Windows 2003 Server that has a DHCP server configured and running.

For more information see "Configuring Options and Classes on Windows Server" at

<http://technet2.microsoft.com/WindowsServer/en/Library/d55609a5-2a1c-4f3f-ba8f-42b21828dc201033.msp>

Creating the vendor class

Use the following steps to create the Colubris vendor class on the DHCP server.

1. Select **Start > Settings > Control Panel > Administrative Tools > DHCP**. The **DHCP** administration page opens.

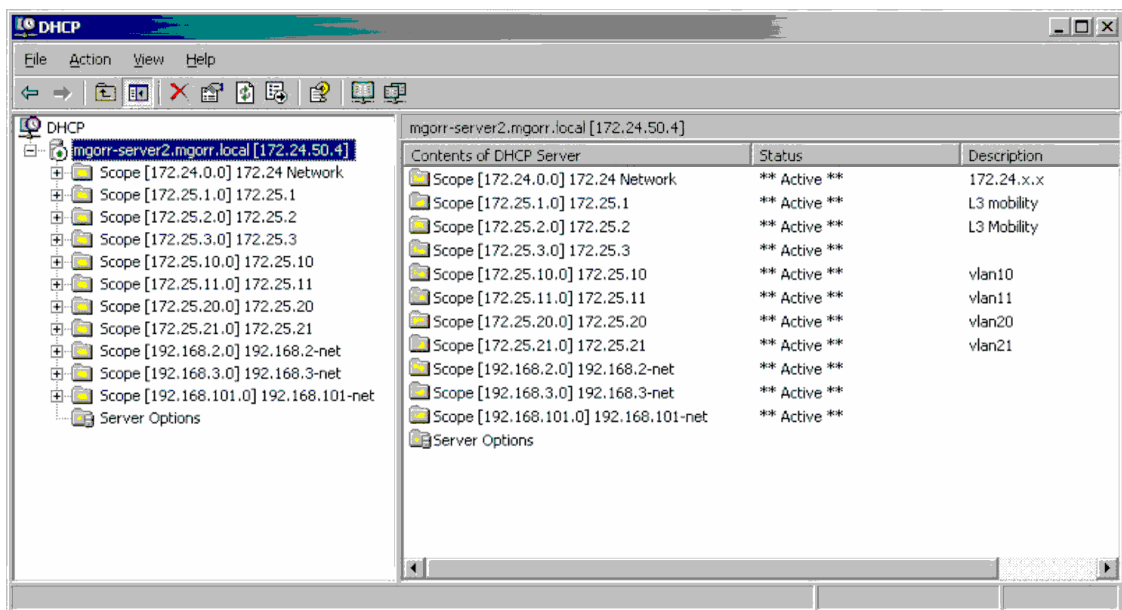

2. On the **DHCP** administration page in the navigation pane at left, select the name of the DHCP server to manage, and then select **Action > Define Vendor Classes**. The **DHCP Vendor Classes** page opens. Several default Microsoft vendor classes are preconfigured.

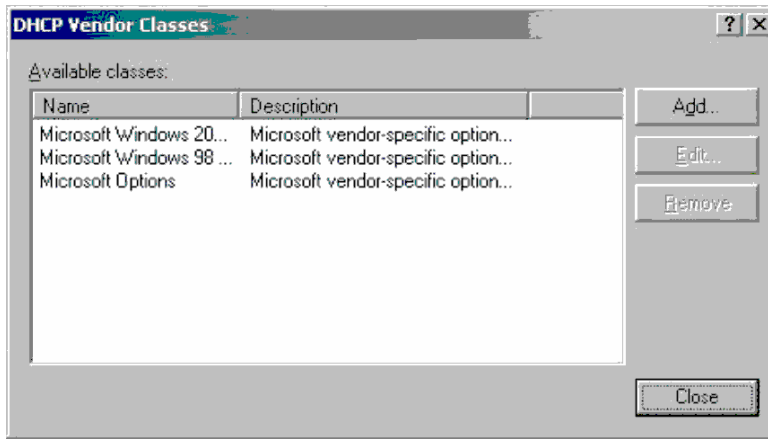

- On the **DHCP Vendor Classes** page, select **Add**. The **New Class** page opens.

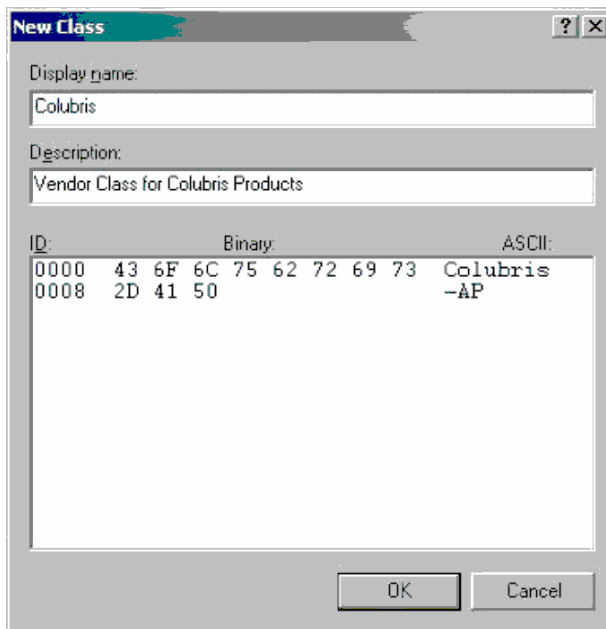

- On the **New Class** page
 - Under **Display name**, specify **Colubris**.
 - Under **Description**, specify any desired descriptive information for this vendor class.
 - Select under **ASCII** and specify **Colubris-AP**.
 - Select **OK**.
- The **New Class** page closes, and you return to the **DHCP Vendor Classes** page. To close the **DHCP Vendor Classes** page and return to the **DHCP** administration page, select **Close**.

Defining vendor class options

Use the following steps to define Colubris vendor class options on the DHCP server.

1. On the **DHCP** administration page, select **Action > Set Predefined Options**. From the **Option class** drop-down menu, select **Colubris**, and then select **Add**. The **Option Type** page opens.

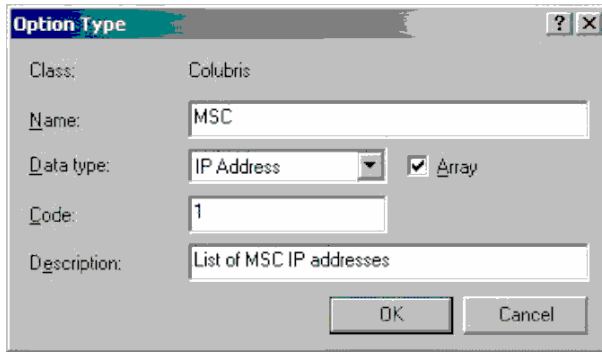

The screenshot shows a dialog box titled "Option Type" with the following fields and controls:

- Class:** Colubris
- Name:** MSC
- Data type:** IP Address (dropdown menu), with an **Array** checkbox.
- Code:** 1
- Description:** List of MSC IP addresses
- Buttons:** OK and Cancel

2. On the **Option Type** page,
 - Under **Name**, specify **MSC** (for MSM controllers).
 - Under **Data type**, select **IP Address** and enable the **Array** checkbox.
 - Under **Code**, specify **1**.
 - Under **Description**, specify **List of MSC IP addresses** (for MSM controller IP addresses).
3. Select **OK** to close the **Option Type** page, and then select **OK** again to return to the **DHCP** administration page.

Applying the vendor class

After you define the Colubris vendor class and its options, you can apply the class to specific Scopes or to the entire DHCP server. You must define the Colubris vendor class for every Scope from which an AP can get an address.

Use the following steps to add the Colubris vendor-specific option to one **Scope** on the DHCP server.

1. On the **DHCP** administration page, in the navigation pane, open the folder that corresponds to the desired **Scope**.
2. Right-click **Scope Options**, and from the resulting menu select **Configure Options**. The **Scope Options** page opens. Select the **Advanced** tab.

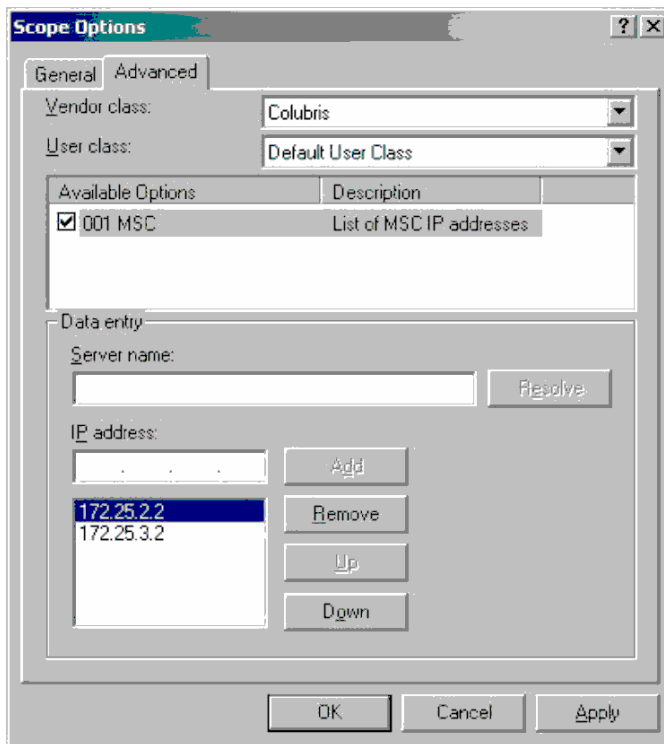

3. On the **Advanced** tab, configure the following:
 - From the **Vendor class** drop-down menu, select **Colubris**.
 - Under **Available options**, enable the **001 MSC** checkbox.
 - Under **IP address**, specify the IP address of the primary controller in your network and select **Add**. Continue to build a list by specifying the IP addresses of all controllers in your network, in descending order of importance.
 - Select **OK**.
4. The controller IP addresses now appear on the DHCP administration page under **Scope Options**. When an AP requests an IP address, these addresses are returned in a DHCP Ack message as option 43.

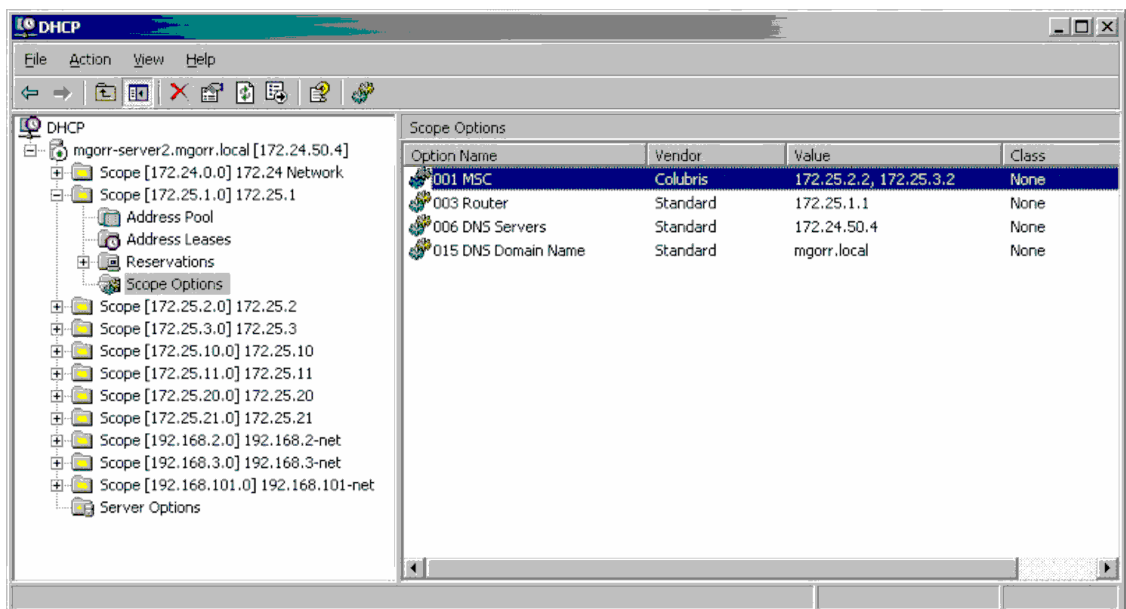

NOTE: For information on solving problems, see “[Troubleshooting](#)” (page 563).

ISC DHCP server configuration

This section shows you how to configure a Linux machine running an Internet Systems Consortium (ISC) DHCP server to use the Colubris Networks vendor class. The procedure assumes that you have a Linux or Unix server that is running the ISC DHCP server.

You configure the ISC DHCP server by editing its configuration file; specifically, the main configuration file, `/etc/dhcpd.conf`.

Following is a simple example of the `/etc/dhcpd.conf` configuration file:

```
# dhcpd.conf
ddns-update-style ad-hoc;
option domain-name "colubris.com";
option domain-name-servers 172.25.1.3;
default-lease-time 3600;

subnet 172.25.1.0 netmask 255.255.255.0 {
    range 172.25.1.100 172.25.1.150;
    option routers 172.25.1.1;
    option subnet-mask 255.255.255.0;
    option broadcast-address 172.25.1.255;
}
subnet 172.25.2.0 netmask 255.255.255.0 {
    range 172.25.2.100 172.25.2.150;
    option routers 172.25.2.1;
    option subnet-mask 255.255.255.0;
    option broadcast-address 172.25.2.255;
}
```

This sample file defines some general options to apply to all clients, as well as two DHCP Scopes 172.25.1.x and 172.25.2.x. You must add lines to the `dhcpd.conf` file to define the following for the ISC server:

- What the Colubris vendor class identifier looks like
- What to return to the client when it sees that identifier.

The following explains the changes that you must make to this sample file and the function of each added line

- Create an option space called **Colubris** and define a variable called **msc-address** within the space by adding the following lines.

```
option space Colubris;

option Colubris.msc-address code 1 = array of ip-address;
```
- Tell the server what to do when the client sends the vendor class identifier **Colubris-AP** by adding the following lines. In this case you want the server to return the options defined in the Colubris space that was created in the first step. Using the **vendor-option-space** command tells the server to return these values using DHCP option 43.

```
if option vendor-class-identifier = "Colubris-AP" {

    vendor-option-space Colubris;

}
```
- Specify the controller IP addresses to return to the client by adding the following lines, where **172.25.2.2** and **172.25.3.2** are the specific IP addresses that you want returned. You can define this option globally or in one or more Scopes. You must define this option on all subnets from which an AP can potentially get an IP address. In this example only clients on the 172.25.1.x subnet get this option.

```
option Colubris.msc-address 172.25.2.2, 172.25.3.2;
```

Following is a revised sample configuration file that contains these additions, which appear in bold:

```
# dhcpd.conf
ddns-update-style ad-hoc;
option domain-name "colubris.com";
option domain-name-servers 172.25.1.3;
default-lease-time 3600;

option space Colubris;
option Colubris.msc-address code 1 = array of ip-address;

if option vendor-class-identifier = "Colubris-AP" {
  vendor-option-space Colubris;
}

subnet 172.25.1.0 netmask 255.255.255.0 {
  range 172.25.1.100 172.25.1.150;
  option routers 172.25.1.1;
  option subnet-mask 255.255.255.0;
  option broadcast-address 172.25.1.255;
option Colubris.msc-address 172.25.2.2, 172.25.3.2;
}

subnet 172.25.2.0 netmask 255.255.255.0 {
  range 172.25.2.100 172.25.2.150;
  option routers 172.25.2.1;
  option subnet-mask 255.255.255.0;
  option broadcast-address 172.25.2.255;
}
```

Troubleshooting

This section shows an Ethereal trace of a DHCP transaction, with the frames edited for readability. Four frames must be exchanged between the client and the server:

1. Client sends a DHCP-Discover.
2. Server sends a DHCP-Offer.
3. Client sends a DHCP-Request.
4. Server sends a DHCP-Ack.

The client sends its vendor class identifier in the DHCP-Request frame. The DHCP field of Frame 3 is expanded below.

The server sends the controller addresses encapsulated as option 43 in the DHCP-Ack frame. Unfortunately, the only way to decode these values is to look at the hexadecimal data. In this case the server returned the following 10 bytes:

```
2b 0a 01 08 ac 19 02 02 ac 19 03 02
```

which can be decoded as shown in the following table.

Segment	Value	Meaning
2b	43	DHCP option 43
0a	10	Field is 10 bytes long
01	01	Colubris option code 1 as defined in the DHCP server

Segment	Value	Meaning
08	08	Option code 1 is 8 bytes long
ac 19 02 02	172.25.2.2	Controller IP addresses to return to the client
ac 19 03 02	172.25.3.2	

Frame 1 - DHCP-Discover

Frame 1 (346 bytes on wire, 346 bytes captured)
 Ethernet II, Src: Colubris_01:5f:05 (00:03:52:01:5f:05), Dst: Broadcast (ff:ff:ff:ff:ff:ff)
 802.1Q Virtual LAN
 Internet Protocol, Src: 0.0.0.0 (0.0.0.0), Dst: 255.255.255.255 (255.255.255.255)
 User Datagram Protocol, Src Port: bootpc (68), Dst Port: bootps (67)
 Bootstrap Protocol

Frame 2 - DHCP-Offer

Frame 2 (346 bytes on wire, 346 bytes captured)
 Ethernet II, Src: Cisco_23:0e:80 (00:0d:bc:23:0e:80), Dst: Colubris_01:5f:05 (00:03:52:01:5f:05)
 802.1Q Virtual LAN
 Internet Protocol, Src: 172.25.1.1 (172.25.1.1), Dst: 172.25.1.201 (172.25.1.201)
 User Datagram Protocol, Src Port: bootps (67), Dst Port: bootpc (68)
 Bootstrap Protocol

Frame 3 - DHCP-Request

Frame 3 (346 bytes on wire, 346 bytes captured)
 Ethernet II, Src: Colubris_01:5f:05 (00:03:52:01:5f:05), Dst: Broadcast (ff:ff:ff:ff:ff:ff)
 802.1Q Virtual LAN
 Internet Protocol, Src: 0.0.0.0 (0.0.0.0), Dst: 255.255.255.255 (255.255.255.255)
 User Datagram Protocol, Src Port: bootpc (68), Dst Port: bootps (67)
 Bootstrap Protocol
 Message type: Boot Request (1)
 Hardware type: Ethernet
 Hardware address length: 6
 Hops: 0
 Transaction ID: 0x4262bc18
 Seconds elapsed: 0
 Bootp flags: 0x0000 (Unicast)
 Client IP address: 0.0.0.0 (0.0.0.0)
 Your (client) IP address: 0.0.0.0 (0.0.0.0)
 Next server IP address: 0.0.0.0 (0.0.0.0)
 Relay agent IP address: 0.0.0.0 (0.0.0.0)
 Client MAC address: Colubris_01:5f:05 (00:03:52:01:5f:05)
 Server host name not given
 Boot file name not given
 Magic cookie: (OK)
 Option 53: DHCP Message Type = DHCP Request
 Option 54: Server Identifier = 172.24.50.4
 Option 50: Requested IP Address = 172.25.1.201
 Option 60: Vendor class identifier = "Colubris-AP"
 Option 12: Host Name = "R054-00118"
 Option 55: Parameter Request List
 End Option
 Padding

Frame 4 - DHCP-Ack

Frame 4 (358 bytes on wire, 358 bytes captured)
 Ethernet II, Src: Cisco_23:0e:80 (00:0d:bc:23:0e:80), Dst: Colubris_01:5f:05 (00:03:52:01:5f:05)
 802.1Q Virtual LAN
 Internet Protocol, Src: 172.25.1.1 (172.25.1.1), Dst: 172.25.1.201 (172.25.1.201)
 User Datagram Protocol, Src Port: bootps (67), Dst Port: bootpc (68)
 Bootstrap Protocol
 Message type: Boot Reply (2)
 Hardware type: Ethernet
 Hardware address length: 6
 Hops: 0
 Transaction ID: 0x4262bc18
 Seconds elapsed: 0
 Bootp flags: 0x0000 (Unicast)
 Client IP address: 0.0.0.0 (0.0.0.0)
 Your (client) IP address: 172.25.1.201 (172.25.1.201)
 Next server IP address: 0.0.0.0 (0.0.0.0)
 Relay agent IP address: 172.25.1.1 (172.25.1.1)

```

Client MAC address: Colubris_01:5f:05 (00:03:52:01:5f:05)
Server host name not given
Boot file name not given
Magic cookie: (OK)
Option 53: DHCP Message Type = DHCP ACK
Option 58: Renewal Time Value = 12 hours
Option 59: Rebinding Time Value = 21 hours
Option 51: IP Address Lease Time = 1 day
Option 54: Server Identifier = 172.24.50.4
Option 1: Subnet Mask = 255.255.255.0
Option 3: Router = 172.25.1.1
Option 15: Domain Name = "mgorr.local"
Option 6: Domain Name Server = 172.24.50.4
Option 43: Vendor-Specific Information (10 bytes)
End Option

```

```

0000 00 03 52 01 5f 05 00 0d bc 23 0e 80 81 00 00 65 ..R._....#.....e
0010 08 00 45 00 01 54 81 68 00 00 ff 11 de 33 ac 19 ..E..T.h.....3..
0020 01 01 ac 19 01 c9 00 43 00 44 01 40 68 ec 02 01 .....C.D.@h...
0030 06 00 42 62 bc 18 00 00 00 00 00 00 00 00 ac 19 ..Bb.....
0040 01 c9 00 00 00 00 ac 19 01 01 00 03 52 01 5f 05 .....R._.
0050 00 00 00 00 00 00 00 00 00 00 00 00 00 00 00 .....
0060 00 00 00 00 00 00 00 00 00 00 00 00 00 00 00 .....
0070 00 00 00 00 00 00 00 00 00 00 00 00 00 00 00 .....
0080 00 00 00 00 00 00 00 00 00 00 00 00 00 00 00 .....
0090 00 00 00 00 00 00 00 00 00 00 00 00 00 00 00 .....
00a0 00 00 00 00 00 00 00 00 00 00 00 00 00 00 00 .....
00b0 00 00 00 00 00 00 00 00 00 00 00 00 00 00 00 .....
00c0 00 00 00 00 00 00 00 00 00 00 00 00 00 00 00 .....
00d0 00 00 00 00 00 00 00 00 00 00 00 00 00 00 00 .....
00e0 00 00 00 00 00 00 00 00 00 00 00 00 00 00 00 .....
00f0 00 00 00 00 00 00 00 00 00 00 00 00 00 00 00 .....
0100 00 00 00 00 00 00 00 00 00 00 00 00 00 00 00 .....
0110 00 00 00 00 00 00 00 00 00 00 63 82 53 63 35 01 .....c.Sc5.
0120 05 3a 04 00 00 a8 c0 3b 04 00 01 27 50 33 04 00 .....;...'P3..
0130 01 51 80 36 04 ac 18 32 04 01 04 ff ff ff 00 03 .Q.6...2.....
0140 04 ac 19 01 01 0f 0c 6d 67 6f 72 72 2e 6c 6f 63 .....mgorr.loc
0150 61 6c 00 06 04 ac 18 32 04 2b 0a 01 08 ac 19 02 al....2.+.....
0160 02 ac 19 03 02 ff .....

```